



PUMP COMPANY

Zoeller Family of Water Solutions™

Product information presented here reflects conditions at time of publication. Consult factory regarding discrepancies or inconsistencies.

Patent No. 9,004,381
Other Patents Pending

TECHNICAL DATA SHEET

SEWAGE WASTE SERIES

Model 915 Grinder Package

Ideal solution for residential wastewater applications or 2" sewage ejector retrofits.

PRODUCT SPECIFICATIONS

MOTOR	Horse Power	1/2	
	Voltage	115	
	Phase	1 Ph	
	Hertz	60 Hz	
	RPM	3450	
	Amps	7.0	
PUMP	Auto On / Off	18" x 30" (45.7 x 76.2 cm)	13-3/8" (34 cm) / 6-1/2" (16.56 cm)
		24" x 24" (61 x 61 cm)	11" (27.9 cm) / 5-1/4" (38.7 cm)
	Discharge Size	1-1/4"	
	Cord Length	15' (5 m) standard	
	Cord Type	UL listed neoprene	
	Max. Head	26' (7.9 m)	
	Max. Flow Rate	32 GPM (121 LPM)	
MATERIALS	Cap	Engineered plastic	
	Upper Motor Housing	Engineered plastic	
	Lower Motor Housing	Cast iron	
	Pump Housing	Engineered plastic	
	Upper Bearing	Ball bearing	
	Lower Bearing	Ball bearing	
	Mechanical Seals	Carbon/ceramic	
	Impeller Type	Non-clogging vortex	
	Impeller	Engineered plastic	
	Hardware	Stainless steel	
	Motor Shaft	AISI 1215	
	Gasket	Closed cell tank gasket; Buna-N pump o-ring	
	Cutter	Hardened stainless steel, Rockwell C55-60	
BASIN	Size	18" x 30" (45.7 x 76.2 cm) or 24" x 24" (61 x 61 cm)	
	Cover	Simplex steel	
	Inlet	4" predrilled	
	Material	18" x 30" (45.7 x 76.2 cm)	Polymolded or fiberglass
24" x 24" (61 x 61 cm)		Polymolded	

18" x 30" (45.7 cm x 76.2 cm)

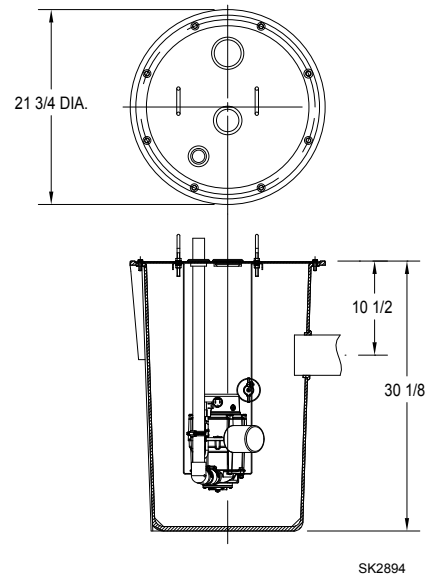

24" x 24" (61 cm x 61 cm)

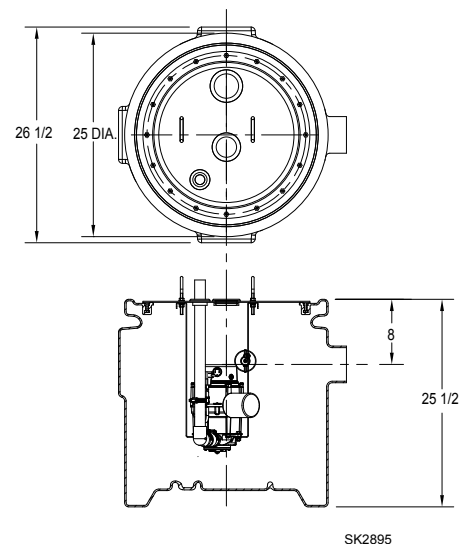

**TOTAL DYNAMIC HEAD
FLOW PER MINUTE**

MODEL		915	
Feet	Meters	Gal.	Liters
5	1.5	32	121
10	3.0	27	102
15	4.6	21	79
20	6.1	13	49
25	7.6	3	11
Shut-off Head:		26 ft. (7.9m)	

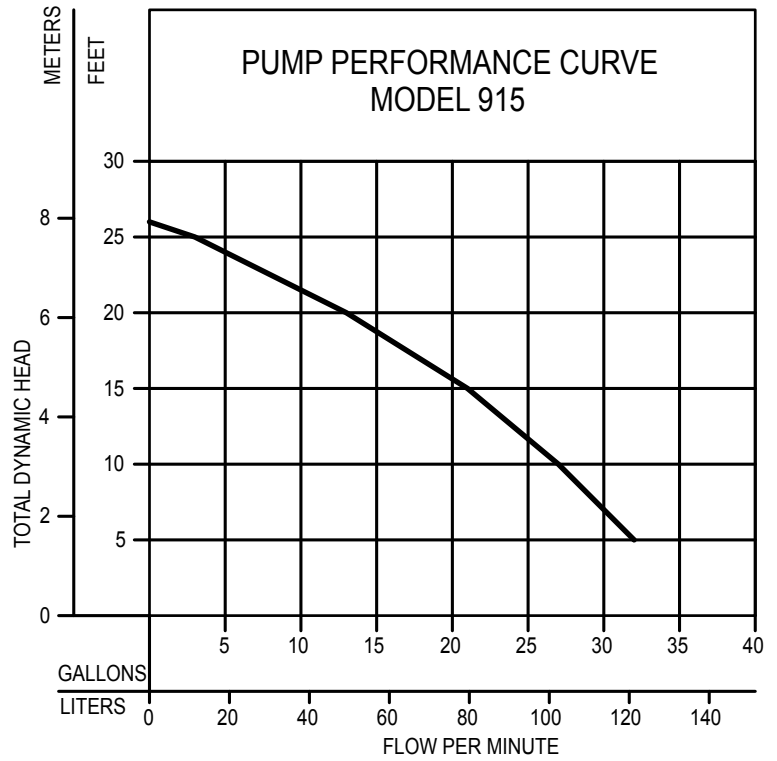

151790

AVAILABLE PACKAGE SYSTEMS

P/N	DESCRIPTION
915-0005	Auto with piggyback, 18" x 30" (45.7 x 76.2 cm) poly molded basin with 2V1-1/4D steel simplex cover with 10-1494 alarm
915-0006	Auto with piggyback, 24" x 24" (61 x 61 cm) poly molded basin with 2V1-1/4D steel simplex cover with 10-1494 alarm
915-0007	Auto with piggyback, 18" x 30" (45.7 x 76.2 cm) fiberglass basin with 2V1-1/4D steel 10' stack simplex cover with 10-1494 alarm
915-0008	Auto with piggyback, 18" x 30" (45.7 x 76.2 cm) poly molded basin with 3V1-1/4D steel simplex cover with 10-1494 alarm
915-0009	Auto with piggyback, 24" x 24" (61 x 61 cm) poly molded basin with 3V1-1/4D steel simplex cover with 10-1494 alarm
915-0010	Auto with piggyback, 18" x 30" (45.7 x 76.2 cm) fiberglass basin with 3V1-1/4D steel 10' stack simplex cover with 10-1494 alarm

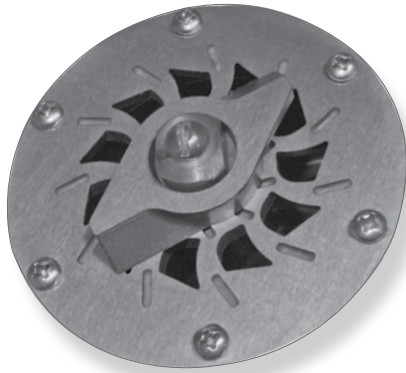

915 Cutter and Plate

Tri-Slice® Cutter Technology includes three independent cutting channels to provide over 250,000 cuts per minute.

IBAD® Integral Baffling and Deflection System allows solids up to 4" (101 mm) to pass.

Basin Scouring System® automatically agitates standing liquid to prevent build-up.

CAUTION

All installation of controls, protection devices and wiring should be done by a qualified licensed electrician. All electrical and safety codes should be followed including the most recent National Electrical Code (NEC) and the Occupational Safety and Health Act (OSHA).