

### DOLLY KIT OVERVIEW

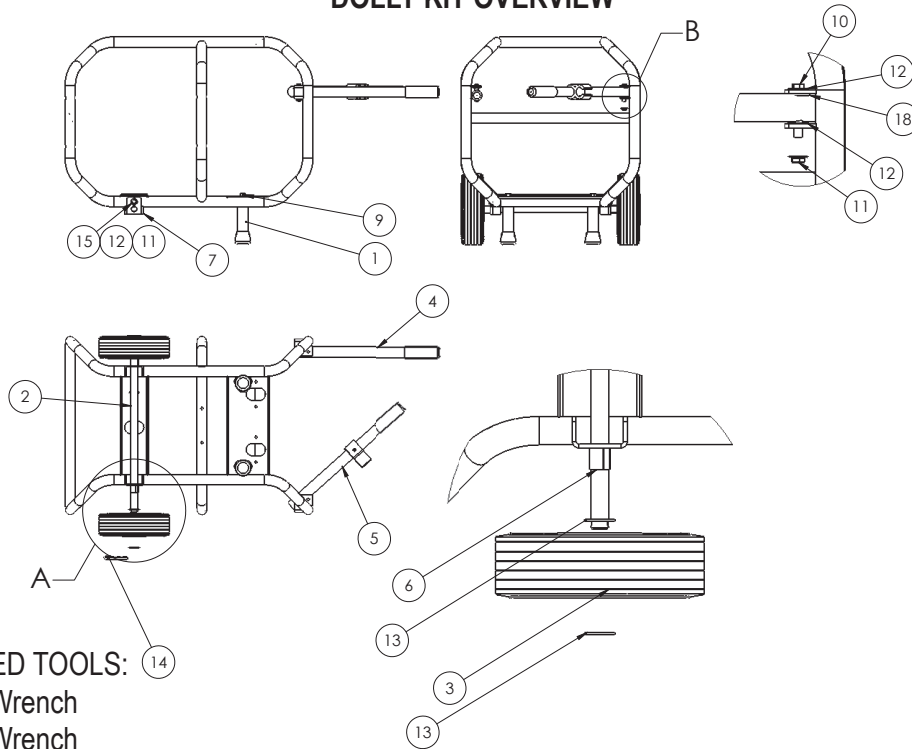

#### REQUIRED TOOLS:

1/2 Inch Wrench

3/4 Inch Wrench

### COMPONENT LIST

| REF. # | PART #     | DESCRIPTION                         | QTY. |
|--------|------------|-------------------------------------|------|
| 1      | 38300-036  | Welded Foot                         | 2    |
| 2      | 64326-026  | Axle, 24.125"                       | 1    |
| 3      | 43657-008  | Wheel 10" Dia x 3" Hard Rubber      | 2    |
| 4      | 16197-001  | Handle                              | 1    |
| 5      | 16197-000  | Handle With Clip                    | 1    |
| 6*     | 64688-008  | Spacer Axle Stub .75" x 1.00"       | 2    |
| 7*     | 15775-026  | Axle Bracket                        | 2    |
| 8*     | 21867-000  | Flat Washer                         | 2    |
| 9*     | 57580-000  | 1/2-13 x 1.5 HHB                    | 2    |
| 10*    | 471-000    | 5/16-18 x 2.25                      | 2    |
| 11*    | 16249-000  | .3125-18 Flange                     | 4    |
| 12*    | 526-000    | 5/16 Flat Washer                    | 6    |
| 13*    | 1178-000   | Flat Washer .760 x 1.375 x .0897    | 4    |
| 14*    | 97883-001  | Pin, Cotter, Hair                   | 2    |
| 15*    | 91672-009  | 5/16-18 x 2                         | 2    |
| 16*    | 16199-036i | Instruction Sheet                   | 1    |
| 18*    | 23558-000  | Flat Washer .3435 x 1 .125 Thk Zinc | 2    |
| 19     | 16199-136  | Parts Bag                           | 1    |

\*Locatated in parts bag 16199-136

## STEP 1

- Open hardware bag and separate components.

### FASTENERS & MISC. COMPONENTS (not shown in actual size)

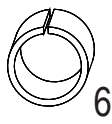

6

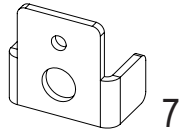

7

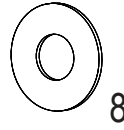

8

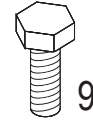

9



10

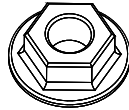

11

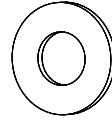

12



13

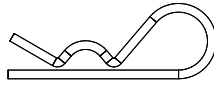

14

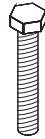

15

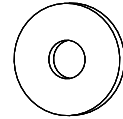

18

### HARDWARE & FASTENER LIST

| REF # | PART #    | DESCRIPTION                         | QTY |
|-------|-----------|-------------------------------------|-----|
| 6*    | 64688-008 | Spacer Axle Stub .75" x 1.00"       | 2   |
| 7*    | 15775-026 | Axle Bracket                        | 2   |
| 8*    | 21867-000 | Flat Washer                         | 2   |
| 9*    | 57580-000 | 1/2-13 x 1.5 HHB                    | 2   |
| 10*   | 471-000   | 5/16-18 x 2.25                      | 2   |
| 11*   | 16249-000 | .3125-18 Flange                     | 4   |
| 12*   | 526-000   | 5/16 Flat Washer                    | 6   |
| 13*   | 1178-000  | Flat Washer .760 x 1.375 x .0897    | 4   |
| 14*   | 97883-001 | Pin, Cotter, Hair                   | 2   |
| 15*   | 91672-009 | 5/16-18 x 2                         | 2   |
| 18*   | 23558-000 | Flat Washer .3435 x 1 .125 Thk Zinc | 2   |

## STEP 2

- Remove the generator from the pallet and block generator up 8 to 10 inches to gain access to the bottom of the cradle assembly. A lifting jack or hoist may also be used if available.

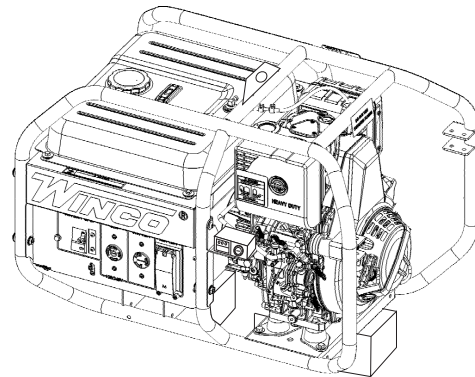

## STEP 3

- Gather all the components needed for the handle install. Either handle can go in either bracket. Use 10x1, 11x1, 12x2, and 18x1 per handle, as shown to the right with  $\frac{1}{2}$ " wrenches. This part is a little tricky. Don't curse at us. Put washer 12 resting on the hole of the bottom of the bracket. Then you'll put washer 18 on the top of the handle, slide it in, and then miraculously line it all up so Part 10 can slide through it all with Part 12 washer on the top. We have complete faith in you to accomplish this. Tighten in accordance with your preference.

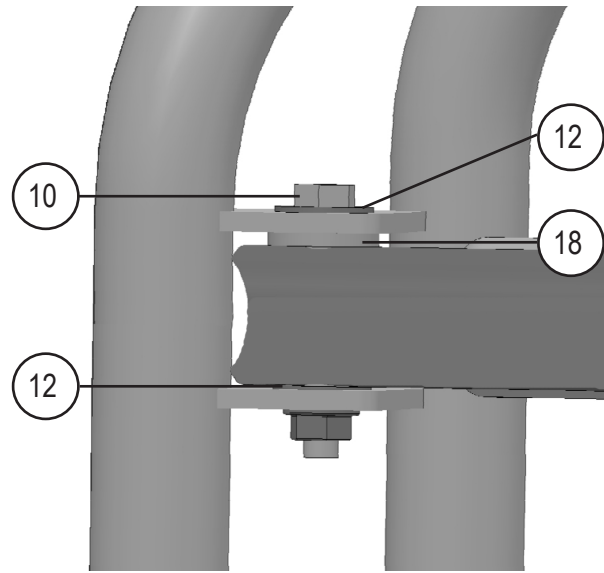

- When completed, your handles should look like this. Part 5 is installed on the back hole of the bracket with the clip facing out. Part 4 is installed on the front hole of the bracket. Either handle can go in either bracket.

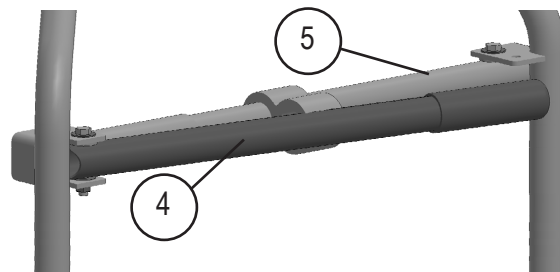

## STEP 4

- Now our efforts will go to the front foot pegs. We are proud of how easy this part is. Use Part 1 with Part 9 and Part 8. Tighten to your preference with  $\frac{3}{4}$  inch wrenches. Done. Easy.

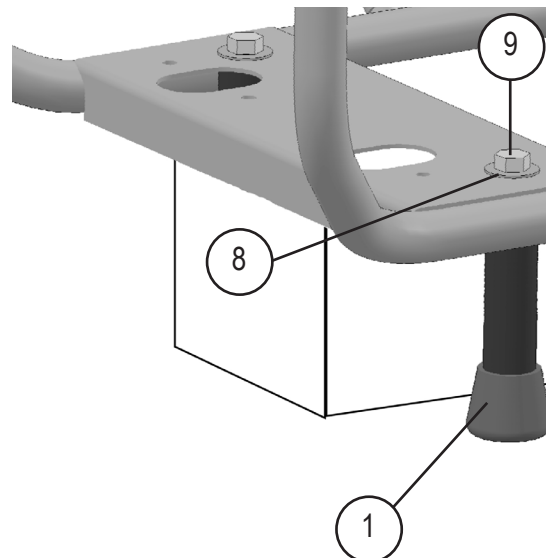

## STEP 5

- All we have left is the back two tires. Since the unit is either blocked or suspended, use Part 7 with Part 15, Part 12, and Part 11(not shown) to secure the axle bracket to the frame. After both sides are on, slide Part 2 through. Then put Part 6 on with Part 13, as shown the the right.

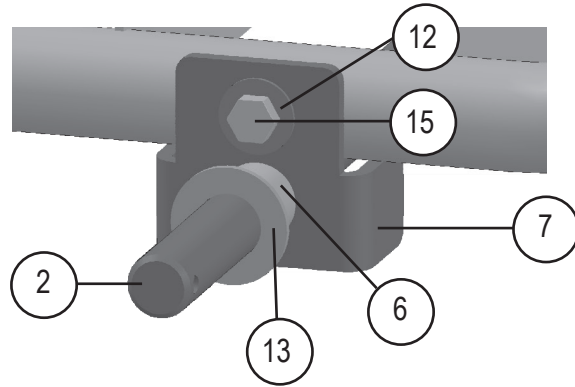

## STEP 6

- Slide on Part 3 and Part 13. Use cotter pin Part 14 to secure as shown to the right.

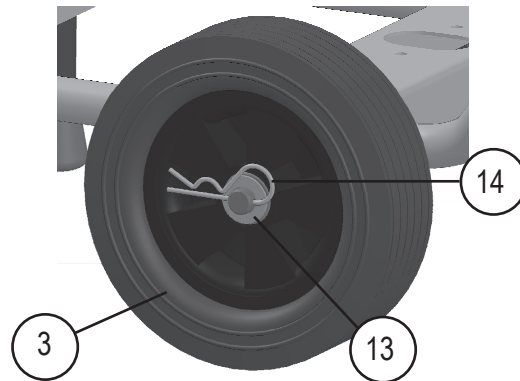

Winco Inc. Service Dept.  
507-357-6831