

WHEEL KIT INSTALLATION

NOTICE

Assembling the generator will require lifting the unit on one side. Install the mounting feet and wheel before adding fuel or oil.

CAUTION

Weight hazard. Always have assistance when lifting the generator.

CARTON CONTENTS

Item	Quantity
Mounting Feet	
• Foot bracket	2
• Shock mount	2
• Bolt, M6x28	2
• Lock nut, M6	2
• Bolt, M8	4
Wheels	
• Wheel	2
• Axle pin	2
• Washer	2
• Cotter pin	2
Handle	
• Handle	1
• Handle pad	1
• Bolt, M10	2
• Handle cap	2

If any parts are missing, contact our service team at service@wpowerreq.com or call 1-855-944-3571.

1. Place generator on a flat surface.
2. Assemble the mounting feet as shown.

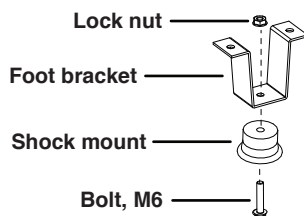

3. Tip the generator on a piece of cardboard or other soft material to protect the frame paint and prevent the generator from sliding.

4. Install the mounting feet to the frame as shown.

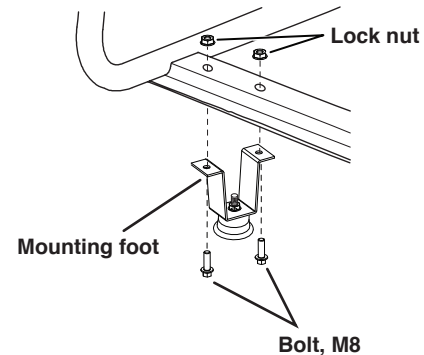

5. Install the wheels as shown with the flanged side of the wheel toward the generator.

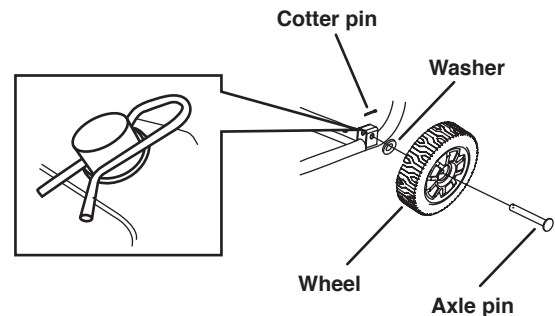

Note: The wheels are only intended for hand transport. The wheels are not suitable for towing the generator either on or off-road.

6. Install the handle pad on the handle. Use rubbing alcohol as a lubricant to ease installation. Spray inside the pad and on the handle and slide the pad onto the handle.

Note: Wait for the alcohol to evaporate before using the handle to transport the generator. This may take several hours.

7. Install the handle to the frame as shown.

