



# Smart Submersible Sump Pump

Please read and save these instructions. Read carefully before attempting to assemble, install, operate or maintain the product described. Protect yourself and others by observing all safety information. Failure to comply with instructions could result in personal injury and/or property damage! Retain instructions for future reference.

## Installation Manual

## Basement Guardian Halo™

### PUMP SPECIFICATIONS

<b>POWER SUPPLY REQUIREMENTS</b>	120 V, 60 Hz
<b>MOTOR</b>	Single Phase, Dielectric Oil Filled
<b>HORSEPOWER</b>	3/4 HP.....
<b>CIRCUIT REQUIREMENTS</b>	15 A (minimum)
<b>DIMENSIONS</b>	11-1/2 in. high x 9-3/4 in. base
<b>ON LEVEL (FACTORY SET)</b>	Approximately 9 in.
<b>OFF LEVEL (FACTORY SET)</b>	Approximately 4 in.

### CONTROLLER SPECIFICATIONS

<b>SWITCH</b>	Solid State Air Switch
<b>CONNECTIVITY</b>	Wi-Fi + BLE
<b>AIR TUBE</b>	PVC

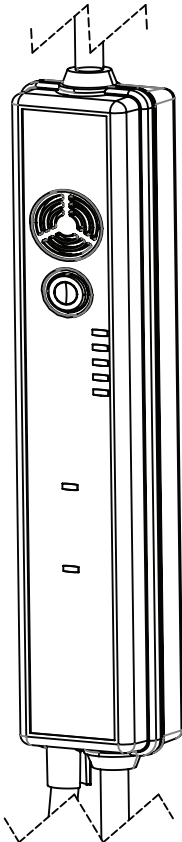

### CONSTRUCTION

<b>MOTOR HOUSING</b>	Stainless Steel
<b>VOLUTE</b>	Cast Iron
<b>IMPELLER</b>	Glass Reinforced Thermoplastic
<b>SHAFT</b>	Steel
<b>DISCHARGE</b>	1-1/2 in. NPT

### PERFORMANCE GAL/HR

Model	HP	Discharge Head (Lift Distance)				
		0 ft	5 ft	10 ft	15 ft	20 ft
Halo	¾	5490	5076	4600	4100	3500

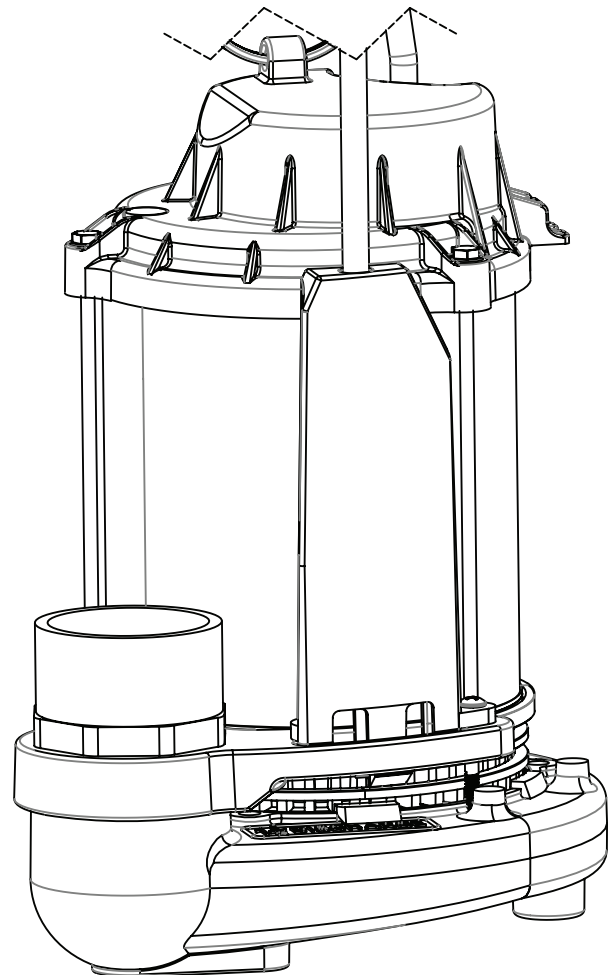

## SUMP PUMP DESCRIPTION

Sump pumps are automatic pumps used to remove ground water from sump pits. The most common application is for basement drainage to prevent flooding in residential buildings. These pumps are designed to pump clear water only. With the innovative and reliable Air Switch, your pump is no longer limited by the mechanical cycles of traditional float switch style pumps. The integrated controller and companion app for your iOS or Android device keeps you informed of the status of your pump; informing you whenever there is a problem and your basement is no longer protected. These pumps are not designed to be used with a portable generator. Installation of this pump outdoors, unprotected from the weather, may cause hazardous conditions and will void warranty. Water inside the pump may freeze, limiting its performance and damaging the pump and pipes.

## UNPACKING

Inspect this unit before it is used. Occasionally, products are damaged during shipment. If the pump or components are damaged, return the unit to the place of purchase for replacement, or call Customer Support (800-237-0987).

## IMPORTANT SAFETY INFORMATION CONSIGNES DE SÉCURITÉ IMPORTANTES

### **WARNING**

**WARNING INDICATES A POTENTIALLY HAZARDOUS SITUATION WHICH, IF NOT AVOIDED, COULD RESULT IN DEATH OR SERIOUS INJURY.**

### **AVERTISSEMENT**

**LA MENTION AVERTISSEMENT INDIQUE UNE SITUATION POTENTIELLEMENT DANGEREUSE QUI, SI ELLE N'EST PAS ÉVITÉE, RISQUE D'ENTRAÎNER DES LÉSIONS CORPORELLES GRAVES OU MÊME LA MORT.**

**RISK OF ELECTRIC SHOCK. TO REDUCE THIS RISK, OBSERVE THE FOLLOWING WARNINGS:**

**RISQUE DE CHOC ÉLECTRIQUE. POUR RÉDUIRE CE RISQUE, TENIR COMPTE DES AVERTISSEMENTS SUIVANTS**



**MAKE SURE THERE IS A PROPERLY GROUNDED RECEPTACLE AVAILABLE.** This pump is supplied with a grounding conductor and grounding-type attachment plug. To reduce the risk of electric shock, be certain that it is connected only to a properly grounded, grounding-type receptacle.

**S'ASSURER QU'UNE PRISE DE MISE À LA TERRE EST DISPONIBLE.** Cette pompe est fournie avec un conducteur et une fiche de mise à la terre. Pour réduire le risque de choc électrique, s'assurer qu'elle est branchée seulement à une prise de courant correctement mise à la terre.

## NOTICE

**This pump is not designed to handle salt water, brine, laundry discharge, water softener, sewage, grey water, or any other application which may contain caustic chemicals and/or foreign materials. Pump and/or property damage could occur if used in these applications and will void warranty.**

## SAFETY SIGNAL WORDS

This manual contains information that is very important to know and understand. This information is provided for SAFETY and to PREVENT EQUIPMENT PROBLEMS. To help recognize this information, observe all safety information labeled danger, warning, caution, and notice.

**FOR ADDED SAFETY** the receptacle must be protected with a ground fault circuit interrupter (GFCI). All wiring must be performed by a qualified licensed electrician and comply with the National Electric Code and all applicable local codes and ordinances.

**POUR PLUS DE SÉCURITÉ**, la prise de courant doit être protégée par un disjoncteur de fuite à la terre. Tout le câblage doit être effectué par un électricien qualifié et être conforme au Code électrique national et à tous les codes et règlements locaux applicables.

**NEVER REMOVE THE GROUND PRONG** from the plug or bypass the grounding wires.

**NE JAMAIS RETIRER LE CONNECTEUR DE MISE À LA TERRE** de la prise ou contourner les fils de mise à la terre.

**MAKE SURE THE POWER SUPPLY HAS A FUSE OR CIRCUIT BREAKER** rated to handle the current (amps) noted on the pump nameplate or cord tag.

**S'ASSURER QUE L'ALIMENTATION ÉLECTRIQUE EST MUNIE D'UN FUSIBLE OU D'UN DISJONCTEUR** d'une valeur nominale appropriée pour supporter l'intensité du courant (ampérage) indiquée sur la plaque signalétique ou l'étiquette du cordon de la pompe.

**DO NOT REMOVE POWER SUPPLY CORD** and strain relief or connect conduit directly to the pump.

**NE PAS RETIRER LE CORDON D'ALIMENTATION ÉLECTRIQUE** et le réducteur de tension, ni connecter le conduit directement à la pompe.

**ALWAYS DISCONNECT THE PUMP** from power supply before installing, servicing or making any adjustments.

**TOUJOURS METTRE LA POMPE HORS TENSION** avant de procéder à l'installation, à l'entretien ou à des réglages.

**DO NOT WALK** on the floor when water is present until all power is turned off. If the electric panel is in the basement, call an electrician.

**NE PAS MARCHER** sur un sol mouillé avant que l'alimentation générale ne soit coupée. Si le tableau électrique est en sous-sol, appeler un électricien.

PLEASE SEE [WWW.WAYNEPUMPS.COM](http://WWW.WAYNEPUMPS.COM) FOR PRODUCT INFORMATION AND INSTALLATION VIDEOS

# INSTALLATION MANUAL

**NEVER HANDLE A PUMP** or motor with wet hands or when standing on a wet or damp floor while the pump is plugged into the power supply.

**NE JAMAIS MANIPULER UNE POMPE** ou un moteur de pompe avec les mains mouillées ou debout dans l'eau ou sur une surface humide.

**RISK OF ELECTRIC SHOCK.** This pump has not been investigated for use in swimming pool and marine areas.

**RISQUE DE CHOC ÉLECTRIQUE.** Cette pompe n'a pas fait l'objet de vérification pour une utilisation dans les piscines et les aires marines.

**DO NOT USE TO PUMP FLAMMABLE OR EXPLOSIVE FLUIDS** such as gasoline, fuel oil, kerosene, etc. Do not use in a flammable and/or explosive atmosphere. Pump should only be used to pump clear water. Personal injury and/or property damage will result and void warranty.

**NE PAS UTILISER POUR POMPER DES FLUIDES INFLAMMABLES OU EXPLOSIFS** tels que l'essence, le mazout, le kérosène, etc. Ne pas utiliser dans un environnement inflammable et/ou explosif. La pompe ne doit être utilisée que pour pomper de l'eau claire. Des blessures corporelles et/ou des dégâts matériels pourraient en résulter.

**PUMPS ARE NOT DESIGNED TO TRANSFER WATER INTENDED FOR DRINKING.** Do not use the pump for moving water that will be used for potable/drinking water. Pump should only be used in applications for which it is designed.

**LES POMPES NE SONT PAS CONÇUES POUR L'ACHEMINEMENT D'EAU DESTINÉE À LA CONSOMMATION.** Ne pas utiliser la pompe pour transporter de l'eau qui sera utilisée comme de l'eau potable/destinée à la consommation. La pompe doit être utilisée uniquement dans les applications pour lesquelles elle est conçue.

## WARNING

**DO NOT USE AN EXTENSION CORD OR SURGE PROTECTOR.** Extension cords and/or surge protectors could present a safety hazard if not sized properly, become damaged or the connection falls into the sump. If receptacle is not within reach of the pump's power cord, contact a qualified licensed electrician to install a new receptacle.

## AVERTISSEMENT

**NE PAS UTILISER DE RALLONGE NI DE PROTECTEUR DE SURTENSION.** Les rallonges et/ou les protecteurs de surtension peuvent présenter un danger pour la sécurité s'ils ne sont pas correctement calibrés, s'ils sont endommagés ou si le raccordement tombe dans le puisard. Si la prise n'est pas à portée du cordon d'alimentation de la pompe, contacter un électricien qualifié pour installer une nouvelle prise.

## CAUTION

**CAUTION INDICATES A POTENTIALLY HAZARDOUS SITUATION WHICH, IF NOT AVOIDED, MAY RESULT IN MINOR OR MODERATE INJURY.**

## MISE EN GARDE

**LA MENTION MISE EN GARDE INDIQUE UNE SITUATION POTENTIELLEMENT DANGEREUSE QUI, SI ELLE N'EST PAS ÉVITÉE, POURRAIT ENTRAÎNER DES BLESSURES MINEURES OU MODÉRÉES.**

**TO REDUCE THE RISK OF HAZARDS THAT CAN CAUSE INJURY OR PROPERTY DAMAGE, OBSERVE THE FOLLOWING WARNINGS:**

**POUR RÉDUIRE LE RISQUE DE DANGERS POUVANT CAUSER DES BLESSURES OU DES DÉGÂTS MATÉRIELS, RESPECTER LES MISES EN GARDE SUIVANTES :**



**IT IS THE INSTALLER'S RESPONSIBILITY TO MAKE SURE THE PUMPS AUTOMATIC SWITCH IS ABLE TO OPERATE WITHOUT ANY OBSTRUCTIONS WITHIN THE BASIN.** It is recommended that the installer test and observe the pump's operation for several cycles after installation.

**IL EST DE LA RESPONSABILITÉ DE L'INSTALLATEUR DE S'ASSURER QUE L'INTERRUPTEUR AUTOMATIQUE DE POMPE PEUT FONCTIONNER SANS AUCUN BLOCAGE À L'INTÉRIEUR DU SYSTÈME.** Il est recommandé que l'installateur teste et observe le fonctionnement de la pompe pendant plusieurs cycles après l'installation.

**IT IS REQUIRED TO USE RIGID PIPING AND FITTINGS** to secure the pump in the basin and reduce pump movement. Pump movement can prevent the switch from operating correctly. Do not use flexible hosing.

**IL EST NÉCESSAIRE D'UTILISER DES TUYAUX ET DES RACCORDS RIGIDES** pour fixer la pompe dans le système et réduire les mouvements de la pompe. Les mouvements de la pompe peuvent empêcher l'interrupteur de fonctionner correctement. Ne pas utiliser de tuyaux flexibles.

**IT IS REQUIRED TO USE A CHECK VALVE** with this pump to prevent the back-flow of clear ground water after each pump cycle.

**NÉCESSITE L'UTILISATION D'UNE VANNE DE CONTRÔLE** cette pompe pour empêcher le reflux d'eau souterraine claire après chaque cycle de pompage.

**DO NOT INSTALL OR OPERATE THE PUMP IF IT HAS BEEN DAMAGED IN ANY WAY.**

**NE PAS INSTALLER OU FAIRE FONCTIONNER LA POMPE SI ELLE A ÉTÉ ENDOMMAGÉE DE QUELQUE MANIÈRE QUE CE SOIT.**

**DO NOT LIFT OR CARRY THE PUMP BY THE POWER CORD OR AIR TUBE.** Use the pump's handle or lift ring.

**NE PAS SOULEVER OU PORTER LA POMPE PAR LE CORDON D'ALIMENTATION O TUBO DE AIRE.** Utiliser la poignée ou la bague de levage de la pompe.

**DO NOT USE THIS PUMP IN MUD, SAND, CEMENT, OIL CHEMICALS, GREY WATER, OR ANY OTHER WATER THAT IS NOT CLEAR GROUND WATER.**

**NE PAS UTILISER CETTE POMPE DANS LA BOUE, LE SABLE, LE CIMENT, LES PRODUITS CHIMIQUES À L'HUILE, DE L'EAU GRISÂTRE OU TOUTE AUTRE EAU QUI N'EST PAS DE L'EAU CLAIRE SOUTERRAINE.**

**DO NOT USE SUMP PUMPS TO HANDLE RAW SEWAGE.**

**NE PAS UTILISER DE POMPES DE PUISARD POUR POMPER LES EFFLUENTS.**

**AN INDEPENDENT HIGH WATER ALARM OR BACK UP PUMP SHOULD BE USED** when risk of property damage from high water levels exists.

**UNE ALARME AUTONOME DE NIVEAU D'EAU ÉLEVÉ OU UNE POMPE DE SAUVEGARDE DOIVENT ÊTRE UTILISÉES** en cas de risque de dégâts matériels causés par des niveaux d'eau élevés.

## ⚠ WARNING

This product can expose you to chemicals, including DEHP, which is known to the State of California to cause cancer, birth defects and reproductive harm. For more information, go to [www.P65Warnings.ca.gov](http://www.P65Warnings.ca.gov).

## ⚠ AVERTISSEMENT

Ce produit peut vous exposer à des produits chimiques, notamment du DOP, reconnus par l'État de Californie comme étant cancérogènes et à l'origine d'anomalies congénitales et de problèmes de l'appareil reproductif. Pour plus de renseignements, visiter le site [www.P65Warnings.ca.gov](http://www.P65Warnings.ca.gov).

## ⚠ CAUTION

**AIR SWITCH** This Air Switch is not adjustable. Any modifications or alterations will void the warranty and/or cause premature failure of the pump, which could lead to property damage.

## ⚠ MISE EN GARDE

**INTERRUPTEUR À AIRE VERTICAL.** Ce aire n'est pas réglable. Toute modification ou altération peut entraîner une défaillance prématurée de la pompe avec pour conséquences des risques de dégâts matériels. Ces modifications ou altérations annuleront la garantie du matériel.

## ⚠ WARNING

**The pump must be plugged in to a GFCI outlet.**

Failure to may result in electrical shock. Keep plug connection and controller protected from contact with water or snow, including splashing water. Plug connection and controller must be kept dry and away from moisture. Failure to follow these instructions can result in death or serious injury.

## ⚠ AVERTISSEMENT

**La bomba debe estar conectada a un tomacorriente GFCI.**

Si no lo hace, puede provocar una descarga eléctrica. Mantenga la conexión del enchufe y el controlador protegidos del contacto con el agua o la nieve, incluidas las salpicaduras de agua. La conexión del enchufe y el controlador deben mantenerse secos y alejados de la humedad. El incumplimiento de estas instrucciones puede provocar la muerte o lesiones graves.

## FCC INTERFERENCE STATEMENT

This equipment has been tested and found to comply with the limits for a Class B digital device, pursuant to Part 15 of the FCC Rules. These limits are designed to provide reasonable protection against harmful interference in a residential installation. This equipment generates, uses and can radiate radio frequency energy and, if not installed and used in accordance with the instructions, may cause harmful interference to radio communications. However, there is no guarantee that interference will not occur in a particular installation. If this equipment does cause harmful interference to radio or television reception, which can be determined by turning the equipment off and on, the user is encouraged to try to connect the interference by one of the following measures:

- Reorient or relocate the receiving antenna.
- Increase the separation between the equipment and receiver.
- Connect the equipment into an outlet on a circuit different from that to which the receiver is connected.
- Consult the dealer or an experienced radio/TV technician for help.

This device complies with Part 15 of the FCC Rules. Operation is subject to the following two conditions.

1. This device may not cause harmful interference, and
2. This device must accept any interference received, including interference that may cause undesired operation.

Changes or modifications not expressly approved by the party responsible for compliance could voice the user's authority to operate the equipment.

## RF EXPOSURE

To comply with FCC/IC RF exposure requirements for mobile transmitting devices, this transmitter should only be used or installed at locations where there is at least 20 cm separation distance between the antenna and all persons.

Under Industry Canada regulations, this radio transmitter may only operate using an antenna of a type and maximum (or lesser) gain approved for the transmitter by Industry Canada. To reduce potential radio interference to other users, the antenna type and its gain should be so chosen that the equivalent isotropically radiated power (e.i.r.p.) is not more than that necessary for successful communication.

This Device complies with Industry Canada License-exempt RSS standards(s). Operation is subject to the following two conditions: 1) this device may not cause interference, and 2) this device must accept any interference, including interference that may cause undesired operation of the device.

## **DECLARACIÓN SOBRE INTERFERENCIAS DE LA FCC**

Este equipo ha sido probado y se ha comprobado que cumple con los límites de un dispositivo digital de clase B, de acuerdo con la sección 15 de las normas de la FCC. Estos límites están diseñados para proporcionar una protección razonable contra interferencias perjudiciales en una instalación residencial. Este equipo genera, usa y puede irradiar energía de radiofrecuencia y, si no se instala y usa de acuerdo con las instrucciones, puede causar interferencias perjudiciales a las comunicaciones por radio. No obstante, no se puede garantizar que no se produzcan interferencias en una instalación en particular. Si este equipo causa interferencia perjudicial en la recepción de radio o televisión, lo cual se puede determinar encendiendo y apagando el equipo, se recomienda al usuario que intente conectar la interferencia mediante una de las siguientes medidas:

- Reorientar o reubicar la antena receptora.
- Aumentar la separación entre el equipo y el receptor.
- Conectar el equipo a una toma de corriente de un circuito diferente al que está conectado el receptor.
- Consultar con el distribuidor o con un técnico de radio/TV experimentado para obtener ayuda.

Este dispositivo cumple con la sección 15 de las normas de la FCC. El funcionamiento está sujeto a las dos condiciones siguientes.

1. Es posible que este dispositivo no cause interferencias perjudiciales, y
2. Este dispositivo debe aceptar cualquier interferencia recibida, incluida la interferencia que pueda causar un funcionamiento no deseado.

Los cambios o modificaciones que no hayan sido explícitamente aprobados por la parte responsable del cumplimiento podrían anular la autoridad del usuario para utilizar el equipo.

## **EXPOSICIÓN A RF**

Para cumplir con los requisitos de exposición a RF de la FCC/IC para dispositivos de transmisión móviles, este transmisor solo se debe usar o instalar en lugares donde haya al menos 20 cm de distancia de separación entre la antena y todas las personas.

Según las reglamentaciones de Industry Canada, este transmisor de radio solo puede funcionar con una antena de un tipo y una ganancia máxima (o menor) aprobada para el transmisor por Industry Canada. Para reducir las posibles interferencias de radio a otros usuarios, el tipo de antena y su ganancia se deben elegir de manera que la potencia isotrópica radiada equivalente (p.i.r.e.) no sea mayor que la necesaria para una comunicación exitosa.

Este dispositivo cumple con los estándares RSS exentos de licencia de Industry Canada. El funcionamiento está sujeto a las dos condiciones siguientes: 1) este dispositivo no puede causar interferencias, y 2) este dispositivo debe aceptar cualquier interferencia, incluidas las interferencias que puedan causar un funcionamiento no deseado del dispositivo.

## **DÉCLARATION D'INTERFÉRENCE DE LA FCC**

Cet équipement a été testé et jugé conforme aux limites d'un appareil numérique de classe B, conformément à la partie 15 des règles de la FCC. Ces limites sont conçues pour fournir une protection raisonnable contre les interférences nuisibles dans une installation résidentielle. Cet équipement génère, utilise et peut émettre une énergie de radiofréquence et, si non installé et utilisé conformément aux instructions, peut causer des interférences nuisibles aux communications radio. Cependant, il n'y a aucune garantie que l'interférence ne se produira pas dans une installation particulière. Si cet équipement cause des interférences nuisibles à la réception radio ou télévisuelle, qui peuvent être déterminées en éteignant et en allumant l'équipement, l'utilisateur est encouragé à essayer de connecter les interférences par l'une des mesures suivantes :

- Réorienter ou déplacer l'antenne de réception.
- Augmenter la distance entre l'équipement et le récepteur.
- Brancher l'équipement dans une prise sur un circuit différent de celui auquel le récepteur est connecté.
- Consulter le revendeur ou un technicien radio/TV expérimenté pour obtenir de l'aide.

Cet appareil est conforme à la partie 15 des règles de la FCC. L'exploitation est soumise aux deux conditions suivantes.

1. Ce dispositif peut ne pas causer d'interférences nuisibles, et
2. Ce dispositif doit accepter toute interférence reçue, y compris toute interférence susceptible de provoquer un fonctionnement indésirable.

Les changements ou les modifications qui ne sont pas expressément approuvés par la partie responsable de la conformité pourraient exprimer le pouvoir de l'utilisateur d'utiliser l'équipement.

## **EXPOSITION AUX RADIOFRÉQUENCES**

Pour se conformer aux exigences d'exposition FCC/IC RF pour les appareils de transmission mobiles, cet émetteur ne doit être utilisé ou installé qu'aux endroits où il y a une distance de séparation d'au moins 20 cm entre l'antenne et toutes les personnes.

En vertu de la réglementation d'Industrie Canada, cet émetteur radio ne peut fonctionner qu'à l'aide d'une antenne d'un type et d'un gain maximal (ou inférieur) approuvés pour l'émetteur par Industrie Canada. Pour réduire les interférences radio potentielles pour les autres utilisateurs, le type d'antenne et son gain doivent être choisis de manière à ce que la puissance isotrope rayonnée équivalente (e.i.r.p.) ne soit pas supérieure à celle nécessaire pour une communication réussie.

Cet appareil est conforme aux normes RSS exemptes de licence d'Industrie Canada. L'exploitation est soumise aux deux conditions suivantes : 1) cet appareil ne doit pas causer d'interférences, et 2) cet appareil doit accepter toute interférence, y compris les interférences susceptibles de provoquer un fonctionnement indésirable de l'appareil.



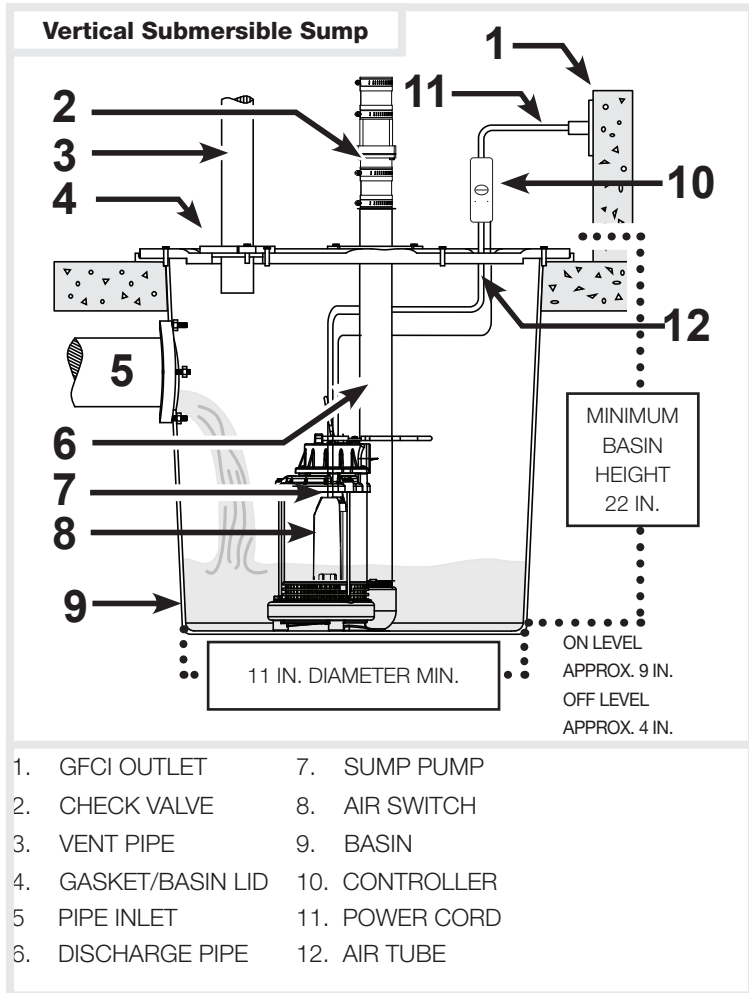

6. Install a check valve (required) to prevent back-flow. The Wayne check valve (57028-001) may be positioned just above the basin to allow easy removal of the pump for cleaning and service.
7. Install a gate valve or ball valve if required by local, regional or state code.
8. Connect pump power supply cord to a ground fault circuit interrupter (GFCI) receptacle.

**NOTE:** Pump will initially run when plugged in to calibrate Air Switch.

**NOTE:** Do not pinch or constrict Air Tube.

9. Fill the basin/pit with water. The pump will activate when the water level has reached level 4 on the controller.
10. The pump will stop when the water level has reached the switch-off level.
11. Fill the basin/pit with water again. While the pump is draining the basin/pit, verify the discharge pipe is carrying the water to a point at least 3 ft. away from the foundation. If the discharge line is exposed to freezing temperatures, the pipe must be positioned in a downward slope away from the foundation so any remaining water will drain away and not freeze.
12. Secure the basin cover and gasket to the basin to prevent debris from falling into the basin, prevent personal injury, and to contain gases and/or odors.
13. For device activation follow the instructions found on the next page.

## TYPICAL SUMP INSTALLATION

1. This installation must be in accordance with the National Electric Code and all applicable local codes and ordinances.
2. Use a basin (purchased separately) or pit that is large enough to accommodate the pump.
3. Clean the basin/pit of all debris.
4. If using a basin, place the pump directly on the bottom of the basin. To prevent damage set the pump on a solid, level surface. Do not place pump directly on clay, earth, gravel or sand. A brick or block must be installed under the pump to provide a solid base.
5. Install discharge plumbing according to local, regional and state codes. Rigid PVC pipe is required. Do not use flex hosing in a permanent application.

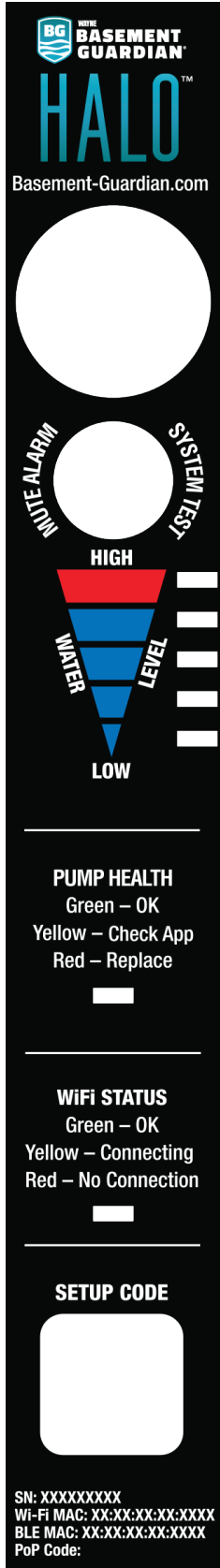

## LED LIGHT DISPLAY (CHECK YOUR APP FOR SPECIFIC REAL TIME PUMP INFORMATION)

Color	Symptom/Possible Cause(s)	Suggested Remedies
Green	1. Good	1. Your pump is good, there is nothing needed
Yellow	1. A clogged pump inlet 2. Electrical voltage or polarity issue detected 3. Water level in your pit is not dropping 4. Your motor is showing signs of aging	1. Open your sump pit and inspect the pump. Make sure the inlet screen is free of debris and there is nothing blocking the flow of water into the pump. 2. Contact an electrician and have them check the voltage and wiring of the outlet. 3. Check your pump to be sure it is properly connected. Then check your discharge pipe for obstructions or leaks that allow water back into the pit. 4. Consider replacing your pump soon to stay protected.
Red	1. There is a critical issue with your pump	1. Replace your pump immediately.

## DIGITAL CONTROLLER BUTTON

Function	Action to Take
Mute Alarm	Short press (at least 1 second)
System Test	Hold for 5 seconds (pump health LED will flash blue) and release
Reboot	Hold for 10 seconds (pump health LED will flash green) and release
Reset WiFi Connection and Reboot	Hold for 15 seconds (pump health LED will flash yellow), release and short press (at least 1 second) again to confirm
Reset to Factory Settings and Reboot	Hold for 20 seconds (pump health LED will flash red), release and short press (at least 1 second) again to confirm

A Button Hold Legend can be found on the back of the controller for your convenience.

**BUTTON HOLD LEGEND**

- System Test: 5 seconds
- Reboot: 10 seconds
- Reset Wifi\*: 15 seconds
- Factory Reset\*: 20 seconds

\* Requires confirmation press

---

IC ID: 21098-ESPWROVERE  
 FCC ID: 2AC7Z-ESP32WROVERE  
 HV: CS-WW-SC-01

**FC IC UL**

## DEVICE ACTIVATION INSTRUCTIONS

**NOTE:** Make sure your Wi-Fi and Bluetooth is connected.

1. Download the Basement Guardian® App from your device's app store.
2. Open the Basement Guardian App and click "+ Add Device" to begin device activation.
3. Select your Halo device.
4. Verify that the status LED on the device is blinking yellow. Click Next to continue.
5. Allow access to your devices camera and use your camera to scan the QR code located on the front of your device.  
NOTE: Camera will automatically scan QR code when brought into view.
6. After the app "Finds" your device, a network list of local connections will be displayed. Select your network and enter your password credentials. Click Send.
7. Once connected to Wi-Fi, your device will be registered.
8. The app will now ask for your zip code. By collecting your zip code, we can link your local weather data with your pump data in the future.

**NOTE:** To use Alexa®, download the WAYNE Skill for your Alexa enabled device.



## TROUBLESHOOTING WARNINGS

### **WARNING**

**ALWAYS DISCONNECT THE PUMP FROM POWER SUPPLY** before installing, servicing or making any adjustments.

### **AVERTISSEMENT**

**TOUJOURS METTRE LA POMPE HORS TENSION** avant de procéder à l'installation, à l'entretien ou à des réglages.

### **WARNING**

**LET PUMP COOL FOR A MINIMUM OF 2 HOURS BEFORE ATTEMPTING TO SERVICE.** Submersible pumps contain oil that become pressurized and hot under normal operating conditions.

### **AVERTISSEMENT**

**LAISSER REFROIDIR LA POMPE PENDANT AU MOINS 2 HEURES AVANT D'ESSAYER DE LA RÉPARER.** Les pompes submersibles contiennent de l'huile qui devient pressurisée et chaude dans des conditions normales de fonctionnement.

1. Submersible pump models have permanently lubricated bearings and require no additional lubrication.
2. Submersible pumps contain dielectric oil for cooling. Dielectric oil can be harmful to the environment. Follow state environmental laws when disposing of pump.
3. The pump motor is equipped with automatic resetting thermal protector and may restart unexpectedly. Protector tripping is an indication of motor overloading as a result of operating the pump at low heads, excessively high or low voltage, inadequate wiring, incorrect motor conditions, or at the end of product life.

## TROUBLESHOOTING CHART FOR PUMP

<b>Symptoms</b>	<b>Possible Cause(s)</b>	<b>Suggested Remedies</b>
Pump will not start or run	<ol style="list-style-type: none"> <li>1. Water level too low</li> <li>2. Blown fuse or tripped circuit breaker</li> <li>3. Low supply voltage</li> <li>4. Motor</li> <li>5. Switch</li> <li>6. Inlet screen clogged</li> <li>7. Switch obstruction</li> </ol>	<ol style="list-style-type: none"> <li>1. Water must be at the appropriate level to activate switch</li> <li>2. If blown, determine cause and then either replace with proper sized fuse or reset breaker</li> <li>3. Contact an electrician</li> <li>4. Replace pump</li> <li>5. Verify Air Tube is not constricted or punctured and is connected to switch and controller</li> <li>6. Remove debris</li> <li>7. Remove obstruction to ensure operation of switch</li> </ol>
Pump starts and stops too often	<ol style="list-style-type: none"> <li>1. Back-flow of water from discharge pipe</li> <li>2. Switch</li> <li>3. Check valve not functioning properly or leaking</li> </ol>	<ol style="list-style-type: none"> <li>1. Install check valve</li> <li>2. Run system test. Also, make sure your Air Tube is not constricted.</li> <li>3. Remove and examine check valve for proper installation and free operation. Replace check valve if necessary.</li> </ol>
Pump shuts off and turns on independently of switch (trips thermal overload protection)	<ol style="list-style-type: none"> <li>1. Excessive water temperature</li> <li>2. Switch</li> <li>3. Switch obstruction</li> <li>4. Obstruction in discharge pipe</li> <li>5. Low supply voltage</li> </ol>	<ol style="list-style-type: none"> <li>1. Pump should not be used for water above 77° F</li> <li>2. Run system test. Also, make sure your Air Tube is not constricted.</li> <li>3. Remove obstruction to ensure operation of switch</li> <li>4. Remove obstruction in discharge piping</li> <li>5. Contact an electrician</li> </ol>

# INSTALLATION MANUAL

## TROUBLESHOOTING CHART (CONTINUED)

<i>Symptoms</i>	<i>Possible Cause(s)</i>	<i>Suggested Remedies</i>
Pump trips GFCI	<ol style="list-style-type: none"><li>1. Bad GFCI</li><li>2. Bad pump</li></ol>	<ol style="list-style-type: none"><li>1. Contact an electrician to replace GFCI</li><li>2. Replace pump</li></ol>
Pump operates noisily or vibrates excessively	<ol style="list-style-type: none"><li>1. Worn bearings</li><li>2. Impeller broken</li><li>3. Piping attachments to building structure too rigid or too loose</li></ol>	<ol style="list-style-type: none"><li>1. Replace pump</li><li>2. Replace pump</li><li>3. Install rubber coupling (available at local hardware stores) to isolate pump vibration from discharge plumbing</li></ol>
Pump will not shut off	<ol style="list-style-type: none"><li>1. Switch</li><li>2. Switch obstructions</li><li>3. Restricted discharge (obstruction in piping)</li><li>4. Excessive inflow or pump not properly sized for application</li></ol>	<ol style="list-style-type: none"><li>1. Run system test. Also, make sure your Air Tube is not constricted or punctured.</li><li>2. Remove obstruction to ensure operation of switch</li><li>3. Remove obstruction from discharge piping</li><li>4. Recheck all sizing calculations to determine proper pump size</li></ol>
Pump operates but delivers little or no water	<ol style="list-style-type: none"><li>1. Low supply voltage</li><li>2. Inlet screen clogged</li><li>3. Broken impeller</li><li>4. Pump not properly sized for application</li><li>5. Check valve stuck closed or installed backwards</li><li>6. Shut off valve closed</li></ol>	<ol style="list-style-type: none"><li>1. Contact an electrician</li><li>2. Remove debris</li><li>3. Replace pump</li><li>4. Recheck all sizing calculations to determine proper pump size</li><li>5. Remove and examine check valve for proper installation and free operation</li><li>6. Open valve</li></ol>

## ROUTINE SUMP MAINTENANCE

The pump should be inspected 3-4 times per year for pump movement or buildup of debris on the switch. Reposition pump if it has moved. Remove any debris that could interfere with the operation of the switch. Lack of proper routine maintenance will void warranty.

- Make sure the pump is plugged in to a working ground fault circuit interrupter (GFCI) outlet and the cord is in good shape. In damp areas, GFCI breakers may trip, effectively shutting off the sump pump. Check in on your sump pump and reset the GFCI if necessary.
- Ensure the pump is standing upright. Vibrations during operation can cause it to fall or tilt onto one side.
- Pour a bucket of water into the pit to make sure the pump starts automatically and the water drains quickly once the pump is on. If the pump doesn't start, have it serviced or replaced.
- Check the inlet screen and clear away any small stones or debris.

## USING YOUR DIGITAL CONTROLLER

### **MUTE ALARM:**

Will silence alarm for 12 hours. For custom mute times, open the companion app while the alarm is active and press the alarm icon next to the alert pop-up.

### **SYSTEM TEST:**

While your pump will automatically run periodic system tests; you can always force a system test via the controller or the companion app. A complete System Test which analyzes all aspects of Pump Health will be performed at Water Level 2 or higher. A partial System Test may be initiated at Water Level 1 or lower but will not be able to analyze all aspects of Pump Health.

### **REBOOT:**

Will perform a Reboot of your device.

### **CHANGE WI-FI CREDENTIALS:**

Use this function to change the Wi-Fi password or SSID used by your device.

**NOTE:** Follow the directions in the app for changing Wi-Fi credentials in device settings.

### **RESET TO FACTORY SETTINGS AND REBOOT:**

**NOTE:** It is highly recommended that a Factory Reset be initiated from the device settings for your pump within the companion app while the device is connected to Wi-Fi. A Factory Reset can be initiated from the app by navigating to the setting for your pump and selecting "Deactivate Pump". Confirming will remove data for this pump from your account and will prompt the Pump Controller to perform a Factory Reset and Reboot.

# INSTALLATION MANUAL

**FOR REPLACEMENT  
PARTS OR CUSTOMER SUPPORT,  
CALL 1-800-237-0987**

**ADDRESS PARTS CORRESPONDENCE TO:  
WAYNE Water Systems  
101 Production Drive  
Harrison, OH 45030 U.S.A.**

**Please provide following information:**

- Model number
- Serial number on cord tag (not to be removed)
- Part description and number as shown in parts list

**Thank you** for making Wayne Water Systems a key part of your home maintenance program. If properly installed, maintained and operated in accordance with Wayne Water Systems' written instructions, your pump should provide you with approximately ( \* ) years of service.

Product Warranty	( * ) Expected Life
5	6

## LIMITED WARRANTY

For five years for the Basement Guardian Halo™ from the date of purchase, from an authorized dealer, Wayne Water Systems will repair or replace, at its option for the original purchaser, any part or parts of its Sump Pumps or Water Pumps ("Product") found upon examination by Wayne Water Systems to be defective in materials or workmanship. Please call Wayne Water Systems (800-237-0987) for warranty instructions. Be prepared to provide the model number and the serial number when exercising this warranty. All transportation charges on Products or parts submitted for repair or replacement must be paid by purchaser. This Limited Warranty is not transferrable. This Limited Warranty does not cover Products which have been damaged as a result of accident, abuse, misuse, neglect, improper installation, improper maintenance, or failure to operate in accordance with WAYNE's written instructions.

This Limited Warranty does not cover Products which have been damaged as a result of accident, abuse, misuse, neglect, improper installation, improper maintenance, or failure to operate in accordance with Wayne Water Systems' written instructions.

**THIS WARRANTY IS IN LIEU OF ANY AND ALL OTHER WARRANTIES, OBLIGATIONS OR AGREEMENTS, EXPRESSED OR IMPLIED, INCLUDING ANY IMPLIED WARRANTY OF MERCHANTABILITY OR FITNESS FOR ANY PARTICULAR PURPOSE, AND ANY RIGHTS OR REMEDIES AGAINST ANY PERSON OR ENTITY UNDER THE UNIFORM COMMERCIAL CODE OR OTHERWISE WITH RESPECT TO THE SALE OF THE PRODUCT. THE REMEDIES AND OBLIGATIONS STATED IN THIS WARRANTY ARE THE SOLE AND EXCLUSIVE REMEDIES OF AND OBLIGATIONS TO THE OWNER FOR ANY AND ALL MATTERS ARISING WITH RESPECT TO OR IN ANY WAY CONNECTED WITH THE PRODUCT, REGARDLESS OF THE SOURCE OR PROVIDER OF SUCH GOODS. IN NO EVENT, WHETHER AS A RESULT OF BREACH OF CONTRACT, WARRANTY TORT (INCLUDING NEGLIGENCE) OR OTHERWISE, SHALL WAYNE WATER SYSTEMS OR ANY AFFILIATE BE LIABLE FOR ANY SPECIAL, INCIDENTAL OR CONSEQUENTIAL DAMAGES.**

You **MUST** retain your purchase receipt along with this form. In the event you need to exercise a warranty claim, you **MUST** send a **copy** of the purchase receipt along with the material or correspondence. Please call Wayne Water Systems (800-237-0987) for return authorization and instructions.

**DO NOT MAIL THIS FORM TO Wayne Water Systems.** Use this form only to maintain your records.

MODEL NO. \_\_\_\_\_ SERIAL NO. \_\_\_\_\_ INSTALLATION DATE \_\_\_\_\_