



**SUBARU**

**Industrial Power Products**

# **EH63V/65V**

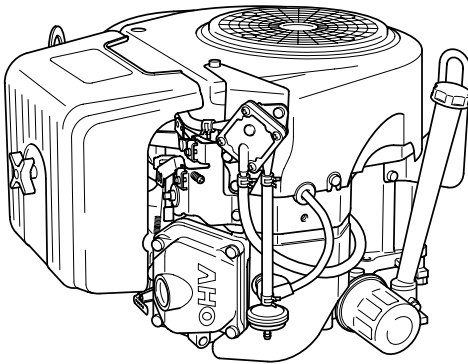

## ***INSTRUCTIONS FOR USE***



2ZZ9020155

# **OHV Gasoline Engines**

(California Proposition 65)

 <b>WARNING:</b> 
The engine exhaust from this product contains chemicals known to the State of California to cause cancer, birth defects or other reproductive harm.

(California only)

## AIR INDEX

To show compliance with California emission regulations, a hangtag has been provided displaying the Air Index level and durability period of this engine.

The Air Index level defines how clean an engine's exhaust is over a period of time. A bar graph scaled from "0" (most clean) to "10" (least clean) is used to show an engine's Air Index level. A lower Air Index level represents cleaner exhaust from an engine.

The period of time (in hours) that the Air Index level is measured is known as the durability period. Depending on the size of the engine, a selection of time periods can be used to measure the Air Index level (see below).

<u>Descriptive Term</u>	<u>Applicable to Emissions Durability Period</u>
Moderate	- 50 hours (engine from 0 to 80 cc) 125 hours (engine greater than 80 cc)
Intermediate	- 125 hours (engine from 0 to 80 cc) 250 hours (engine greater than 80 cc)
Extended	- 300 hours (engine from 0 to 80 cc) 500 hours (engine greater than 80 cc) 1000 hours (225 cc and greater)

**Notice :** This hangtag must remain on this engine or piece of equipment, and only be removed by the ultimate purchaser before operation.

**Notice :** FEDERAL EMISSION COMPONENT DEFECT WARRANTY and CALIFORNIA EMISSION CONTROL WARRANTY are applicable to only those engines/ generators complied with EPA (Environmental Protection Agency) and CARB (California Air Resources Board) emission regulations in the U.S.A.

**Notice :** To the engines/generators exported to and used in the countries other than the U.S.A., warranty service shall be performed by the distributor in each country in accordance with the standard SUBARU engine/generator warranty policy as applicable.

# FOREWORD

Thank you very much for purchasing a **SUBARU ENGINE**.

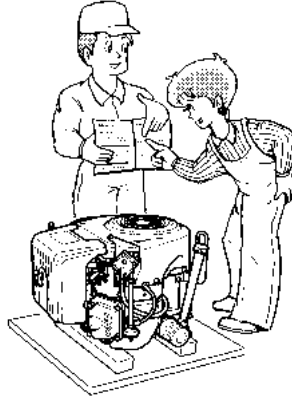

Your **SUBARU ENGINE** can supply the power to operate various sorts of machines and equipment.

Please take a moment to familiarize yourself with the proper operation and maintenance procedures in order to maximize the safe and efficient use of this product.

Due to constant efforts to improve our products, certain procedures and specifications are subjected to change without notice.

When ordering spare parts, always give us the **MODEL**, **SPECIFICATION** and **SERIAL NUMBER** of your engine.

Please fill in the following blanks after checking the specification number on your engine.

**SPEC NO.**

<b>E</b>	<b>H</b>																		
----------	----------	--	--	--	--	--	--	--	--	--	--	--	--	--	--	--	--	--	--

**SERIAL NO.**

--	--	--	--	--	--	--	--









For your nearest distributor (and/or dealer), you are able to check at our website of the following URL;

<http://www.subaru-robin.jp>





# CONTENTS























1. SAFETY PRECAUTIONS .....	1
2. COMPONENTS .....	4
3. PRE-OPERATION CHECKS .....	5
4. BATTERY INSTALLATION .....	7
5. OPERATING YOUR ENGINE .....	9
6. EASY TROUBLESHOOTING .....	12
7. SPARK ARRESTER (OPTIONAL) .....	14
8. MAINTENANCE SCHEDULE .....	15
9. "HOW-TO" MAINTENANCE .....	17
10. PREPARATIONS FOR STORAGE .....	21
11. SPECIFICATIONS .....	22

# SYMBOLS

	<i>Read manual.</i>		<i>Shut off fuel valve when the engine is not in use.</i>
	<i>Stay clear of the hot surface.</i>		<i>Check for leakage from hose and fittings.</i>
	<i>Exhaust gas is poisonous. Do not operate in an unventilated room or enclosed area.</i>		<i>Fire, open flame and smoking prohibited.</i>
	<i>Stop the engine before refueling.</i>		<i>HOT, avoid touching the hot area.</i>

## USA and CANADA only

	<i>Read INSTRUCTIONS FOR USE before use.</i>		<i>The engine emits toxic gas can kill you in minutes. Do not run in an enclosed area.</i>		<i>Hot surface can burn you. Stay away if engine has been running.</i>
	<i>Gasoline is extremely flammable and its vapors can explode.</i> <ul style="list-style-type: none"> <li>• Stop the engine before refueling.</li> <li>• Check for leakage from hoses and fittings.</li> <li>• Shut off fuel valve when the engine is not in use.</li> </ul>				

	<i>On (Run)</i>		<i>Engine start (Electric start)</i>		<i>Fuel (gasoline)</i>
○	<i>Off (Stop)</i>		<i>Engine stop</i>		<i>Fuel (diesel)</i>
	<i>Engine oil</i>		<i>Cold engine</i>		<i>Fuel shut-off</i>
	<i>Add oil</i>		<i>Warm engine</i>		<i>Fuel system failure / malfunction</i>
	<i>Battery</i>		<i>Electrical preheat (Low temperature start aid)</i>		<i>Choke</i>
	<i>Fast</i>		<i>Run position</i>		<i>Plus ; positive polarity</i>
	<i>Slow</i>		<i>Stop position</i>		<i>Minus ; negative polarity</i>
	<i>Primer</i>		<i>Push primer</i>		<i>Do not push primer</i>
<b>2X</b>	<i>Two times</i>				

# 1. SAFETY PRECAUTIONS

---

Please make sure you review each precaution carefully.

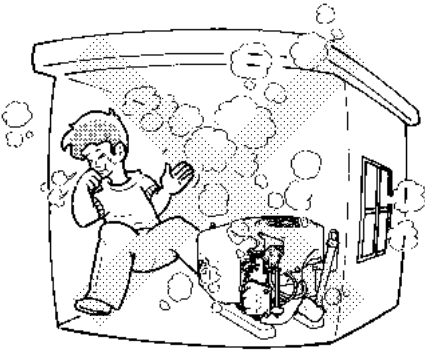

## EXHAUST PRECAUTIONS

- Never inhale exhaust gasses. They contain carbon monoxide, a colorless, odorless and extremely dangerous gas which can cause unconsciousness or death.
- Never operate the engine indoors or in a poorly ventilated area, such as tunnel, cave, etc.
- Exercise extreme care when operating the engine near people or animals.
- Keep the exhaust pipe free of foreign objects.

## REFUELING PRECAUTIONS

- Be sure to stop the engine prior to refueling.
- Do not overfill the fuel tank.
- If fuel is spilt, wipe it away carefully and wait until the fuel has dried before starting the engine.
- After refueling, make sure that the fuel cap is secured to prevent spillage.



## FIRE PREVENTION

- Do not operate while smoking or near an open flame.
- Do not use around dry brush, twigs, cloth rags, or other flammable materials.
- Keep the engine at least 3 feet (1 meter) away from buildings or other structures.
- Keep the engine away from flammables and other hazardous materials (trash, rags, lubricants, explosives).

---

## PROTECTIVE COVER

- **Place the protective covers over the rotating parts.**

If rotating parts such as the drive shaft, pulley, belt, etc. are left exposed, they are potentially hazardous.

To prevent injury, equip them with protective covers or shrouds.

- **Be careful of hot parts.**

The muffler and other engine parts become very hot while the engine is running or just after it has stopped. Operate the engine in a safe area and keep children away from the running engine.

- **Never make adjustments on the machinery while it is connected to the engine, without first removing the ignition cable from the spark plug.**

Turning the crankshaft by hand during adjusting or cleaning might start the engine, and machinery with it, causing serious injury to the operator.

- **Never run the engine with governor disconnected, or operate at speeds in excess of 3600 rpm load.**

## SURROUNDINGS

- **Operate the engine on a stable, level surface free of small rocks, loose gravel, etc.**

<b>NOTE</b>
-------------

Operating the engine at a steep incline may cause seizure due to improper lubrication even with a maximum oil level.
--

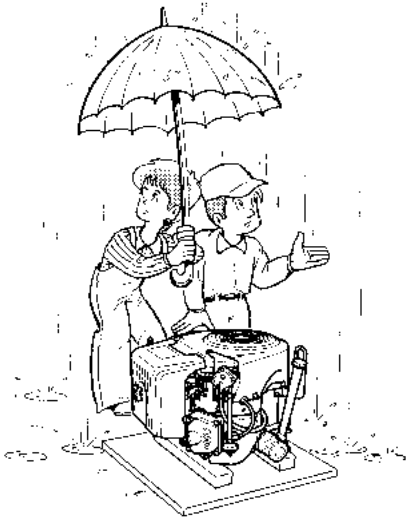

- Drain the fuel when transporting the engine.
- Do not move the engine while in operation when it has been removed from the equipment.
- Keep the unit dry (do not operate it in rainy conditions).



## PRE-OPERATION CHECKS.

- Carefully check fuel hoses and joints for looseness and fuel leakage. Leaked fuel creates a potentially dangerous situation.
- Check bolts and nuts for looseness. A loose bolt or nut may cause serious engine trouble.
- Check the engine oil and refill if necessary.
- Check the fuel level and refill if necessary. Take care not to overfill the tank.
- Wear snug fitting working clothes when operating the engine. Loose aprons, towels, belt, etc., may be caught in the engine or drive train, causing a dangerous situation.

## PRECAUTIONS ON THE HANDLING OF THE WARNING LABEL

- Warning labels are affixed to our engines with regard to particularly serious dangers. When using the engines, please use them safely after carefully reading the instruction manual and understanding the dangers.

**Warning Label Exclusively for the United States and Canada**

▲ WARNING		▲ AVERTISSEMENT		▲ ADVERTENCIA	
 Read INSTRUCTIONS FOR USE before use.	Gasoline is extremely flammable and its vapors can explode. Stop the engine before refueling.	 Lire les INSTRUCTIONS d'usage avant de mettre le moteur en marche.	Le moteur et son environnement sont extrêmement inflammables et les vapeurs peuvent exploser. Arrêtez le moteur avant de verser le carburant.	 Leer las INSTRUCCIONES PARA EL USO antes de utilizar el motor.	La gasolina es extremadamente inflamable y sus vapores pueden explotar. Detener el motor antes de hacer el llenado de combustible.
 The engine emits toxic gas that can be inhaled and not run in an enclosed area.	Check for leakage from hoses and fittings. Shut off fuel valve when the engine is not in use.	 Ce moteur émet de gaz toxiques qui peuvent être inhalés et ne pas fonctionner dans un espace clos.	Ver la parte de combustible de la parte de combustible de la parte de combustible.	 Este motor emite gases tóxicos que pueden ser inhalados y no debe utilizarse en un espacio cerrado.	Compruebe la presión de combustible antes de utilizar el motor.
 Hot surface can burn you. Stay away of engine heat.		 Les surfaces chaudes peuvent brûler. Évitez de rester trop près du moteur.	Evitez de rester trop près du moteur.	 Las superficies calientes pueden quemar. Manténgase alejado de las partes calientes del motor.	Compruebe la presión de combustible cuando no se utilice el motor.

For use in the United States or Canada, please affix the label suited to the region from among the enclosed warning labels.

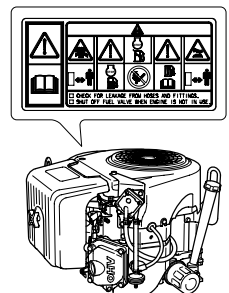



# 2. COMPONENTS

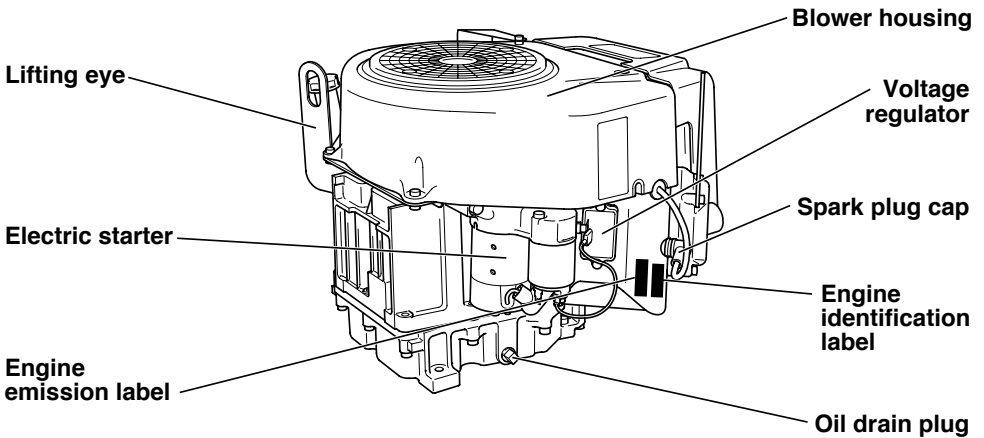
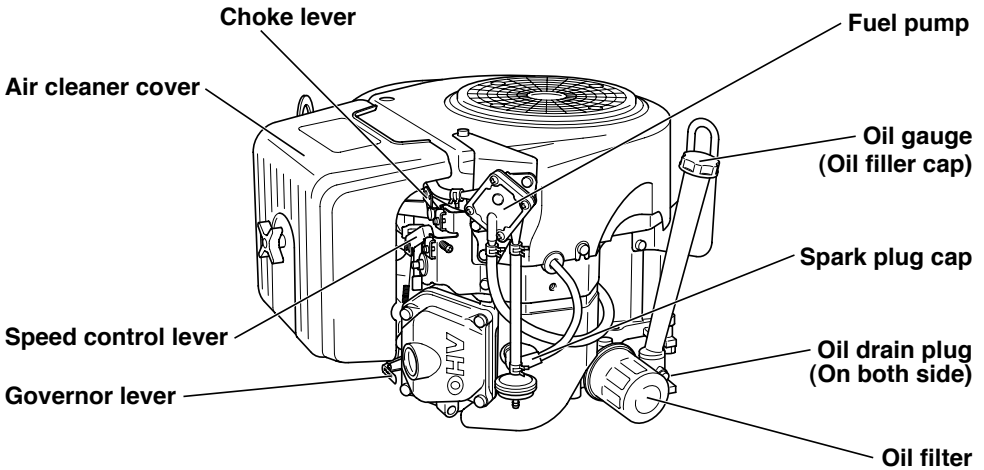

## REMARKS :

- Fuel tank (filter incorporated type is recommended), valve and hoses are requested to prepare and make arrangements for connecting properly to carburetor.
- For starter motor operation, key switch (\*) is recommended to be adopted onto this engine.  
In combination with battery and cable to be prepared, proper electric wiring arrangements are needed before normal engine operation.

\* : Control box with key switch incorporated is available as optional part.

# 3. PRE-OPERATION CHECKS

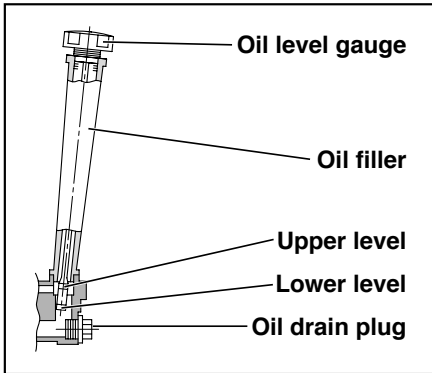

## CHECK ENGINE OIL

Before checking or refilling engine oil, be sure the engine is located on a stable, level surface and stopped.

- If the oil level is below the lower level line on the oil gauge, refill with the proper oil (see table) to the upper level.

### OIL CAPACITY : 2.0 L

- When filling oil in the engine, keep the engine at the horizontal position, and then fill oil up to the upper mark of the oil gauge.
- When checking the oil level, do not screw the oil level gauge into the filler neck.
- When the engine is operated once, the oil level lowers a little. Make sure of filling oil once again, up to the upper mark of the oil gauge.
- Change oil if it is contaminated. (See page 15 Maintenance Schedule.)
- Use 4-stroke automotive detergent oil of API service class SE or higher grade (SG, SH or SJ is recommended).
- If multi-grade oil is employed, oil consumption tends to increase when the ambient temperature is high.

Single grade	5W						
	10W						
Multi grade	20W						
	#20						
Ambient temperature	#30						
	#40						
	10W-30						
	10W-40						
	-20	-10	0	10	20	30	40°C
	-4	14	32	50	68	86	104°F

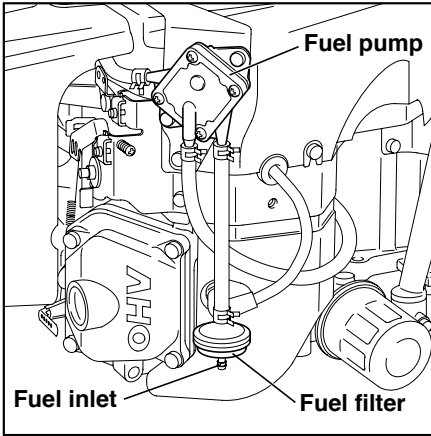

## CHECK FUEL

### WARNING

Do not refuel while smoking, near an open flame or other potential hazards.

- The fuel tank shall be provided separately, because the engine is not equipped with fuel tank. Also fuel valve and strainer should be prepared. Make proper connection with fuel hoses to the fuel pump.
- Make sure of setting the fuel tank at a position lower than the carburetor level. If it is unavoidable to install the fuel tank at a high place, make sure of providing a fuel valve at the outlet of the fuel tank. If the fuel tank is installed at a high place, make sure to close the fuel valve when the engine is not being operated.
- A serious accident may occur when the fuel hose comes off. Make sure of inserting it firmly in the joint and fixing it securely with a hose clamp.
- Use unleaded automotive gasoline only.
  - Unleaded regular/premium or reformulated gasoline containing no more than 10% Ethanol (E10), or 15% MTBE may also be used.
  - Never use gasoline containing ethanol exceeding 10%, or MTBE exceeding 15% because engine or fuel system damage could result.
  - Never use stale or contaminated gasoline.
  - Use of these non-recommended fuels may result in reduced performance and/or denial of warranty.
- Stop the engine and close the fuel valve before filling the fuel tank.
- Wipe off any spilled fuel before starting the engine.

# 4. BATTERY INSTALLATION

For starter motor operation, proper electric wiring arrangements are needed before normal engine operation.

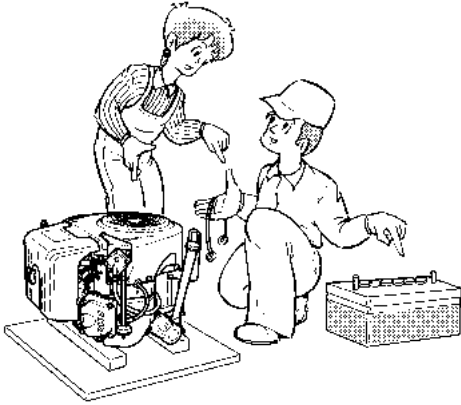

## PARTS TO BE PREPARED

- Use a battery rated 12V-30AH or larger.
- Use key switch for starter motor operation.
- Use a proper cable and ground wire to connect battery and key switch.

## BATTERY CABLE

CABLE LENGTH	CABLE DIA.	WIRE GAUGE		
		AWG(BS) BWG	SAE	JIS
Less than 1.5 m	7.3 mm	1	6	AV15
1.5 m to 2.5 m	8.5 mm	0	4	AV20
2.5 m to 4.0 m	10.8 mm	3/0	2	AV30

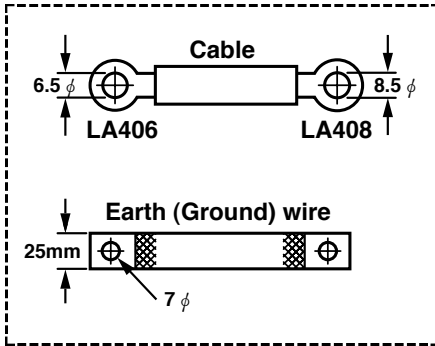

For GROUND WIRE, use a flat braided wire of 0.03 sq. in. or larger sectional area. (SAE GAUGE 4)

## KEY SWITCH CABLE

CABLE LENGTH	CABLE DIA.	WIRE GAUGE		
		AWG(BS)	BWG	JIS
Less than 1.5 m	1.5 mm	14	16	AV1.25
1.5 m to 3.0 m	1.9 mm	12	14	AV2
3.0 m to 5.0 m	2.4 mm	10	13	AV3

## WIRING

- Connect positive terminal of the electric starter and positive terminal of the battery with battery cable.
- Ground negative terminal of the battery to the body of engine or machine with ground wire.

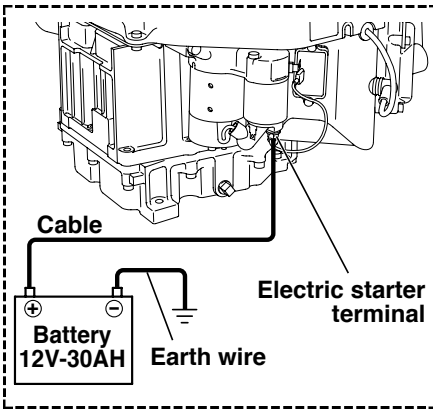

### NOTE

Tighten bolts and nuts on terminals securely so they will not be loosened by vibration.

## (WIRING DIAGRAM)

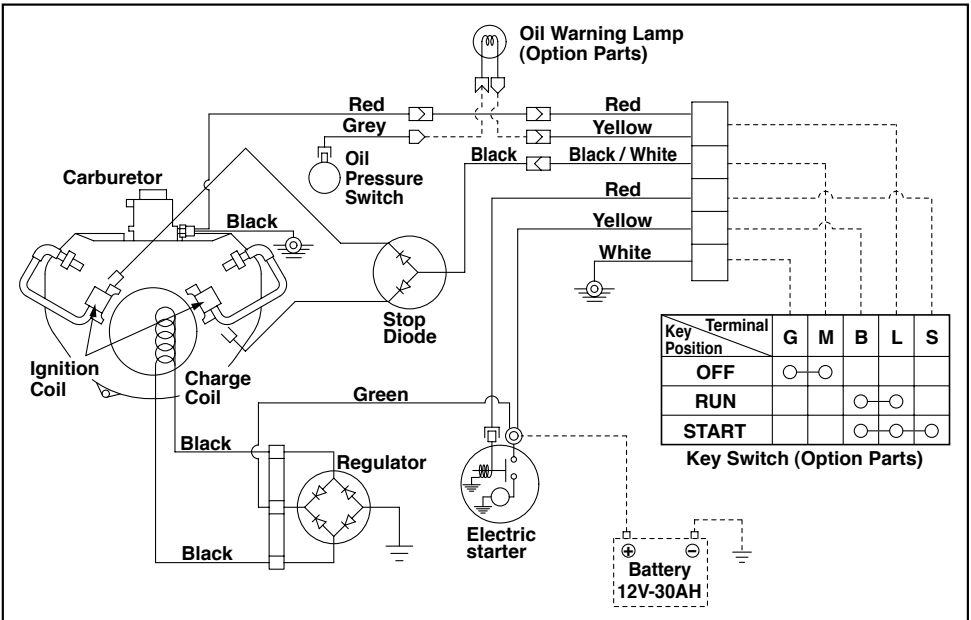

Select wires of proper gauge and connect battery and key switch as shown by the dotted line in the wiring diagram.

# 5. OPERATING YOUR ENGINE

## STARTING

### FUEL VALVE

1

Make sure to open the fuel valve.

### CHOKE LEVER

3

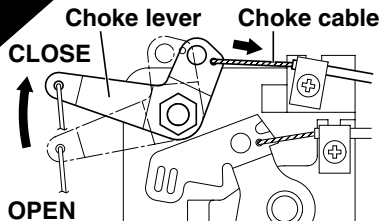

Pull the choke cable.

- If the engine is warm or the ambient temperature is high, pull the choke cable half-way, or keep it fully open.
- If the engine is cold or the ambient temperature is low, pull the choke cable fully.

### SPEED CONTROL LEVER

2

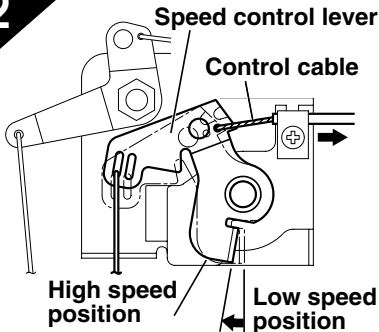

Set the speed control lever 1/3 of the way towards the high speed position.

### ELECTRIC STARTER

4

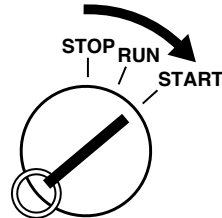

Turn the key switch to the "START" position.

- Do not operate the electric starter continuously for more than 5 seconds, even if the engine does not start.
- If the engine failed to start, set the key to the "RUN" position and wait for about 10 seconds before retrying.
- Never turn the key switch to the "START" position while engine is running.

## CHOKE LEVER

5

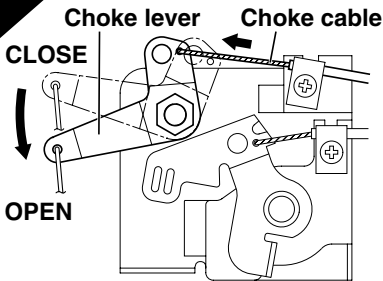

- After starting the engine, gradually open choke by pushing the choke cable and finally keep it fully opened.
- Do not fully open the choke immediately when the engine is cold or the ambient temperature is low, because the engine may stop.

## RUNNING

### SPEED CONTROL LEVER

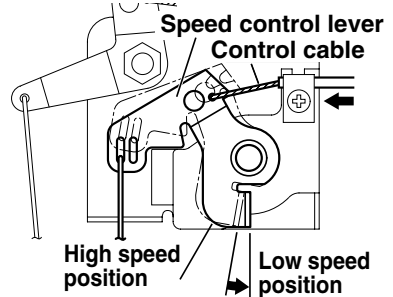

After the engine starts, set the speed control lever at the low speed position and warm it up without load for a few minutes.

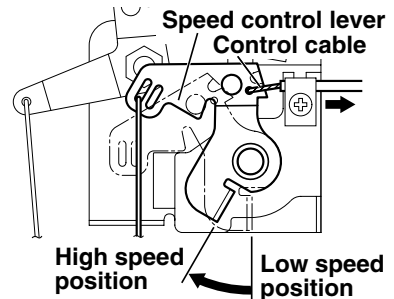

Gradually move the speed control lever toward the high speed position and set it at the required engine speed.

#### NOTE :

Whenever high speed operation is not required, slow the engine down (idle) by moving the speed control lever to save fuel and extend engine life.

## STOPPING

### SPEED CONTROL LEVER

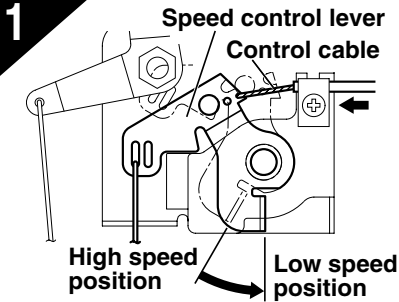

Set the speed control lever at the low speed position and allow the engine to run at low speed for 2 or 3 minutes before stopping.

### FUEL VALVE

**3**

Make sure to close the fuel valve.

### ELECTRIC STARTER

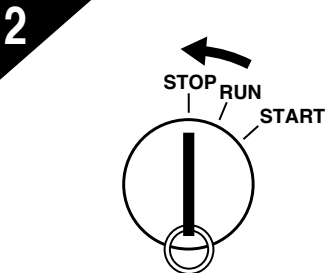

Turn the key switch to the "STOP" position.

### STOPPING ENGINE WITH THE FUEL VALVE

Close the fuel valve and wait for a while until the engine stops.

Avoid to let the fuel remain in the carburetor over long periods, or the passages of the carburetor may become clogged with impurities, and malfunctions may result.

Set the key switch to the STOP position after stopping the engine.



# 6. EASY TROUBLESHOOTING

---

## WHEN ENGINE WILL NOT START:

- Perform the following checks before you take the engine to your SUBARU Industrial Power Products dealer.
- If you still have trouble after completing the checks, take the engine to your nearest SUBARU Industrial Power Products dealer.

## Is there enough compression?

If the spark plug is loose, tighten it.

## Is the spark plug wet with gasoline?

1. Choke (close choke lever) and slowly start the engine for 2 or 3 seconds. Remove the plug and check if its electrode is wet. If the electrode is wet, fuel is well supplied to your engine.
2. When the electrode is dry, check where the fuel stops. (Check the fuel intake of the carburetor and fuel strainer intake.)
3. In case the engine does not start with well supplied fuel, try using fresh fuel.

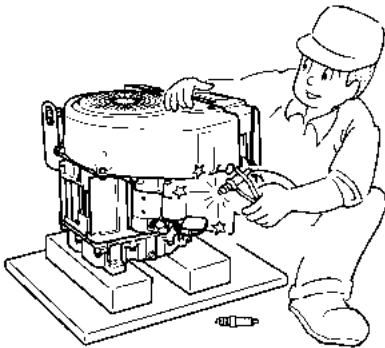

## Is there a strong spark across the electrode?

1. Remove the spark plug and connect it to the plug cap. Turn key switch to START position while grounding spark plug against engine body.
2. Try with a new spark plug if the spark is weak or there is no spark.
3. The ignition system is faulty if there is no spark with a new spark plug. Take your engine to your nearest SUBARU Industrial Power Products dealer.

---

**⚠ WARNING**

**Wipe out spilled fuel carefully before checking.  
Place spark plug as far away from spark plug hole as possible.  
Do not hold spark plug by hand while checking.**

**Is your battery well charged ?**

If your battery for the electric starter is overly discharged, your engine will not start.

Consult your nearest dealer or service shop.

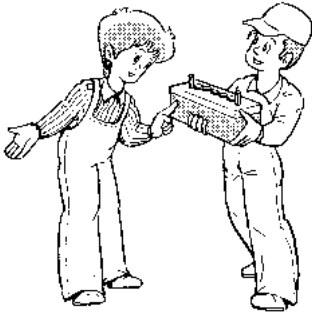

# 7. SPARK ARRESTER (OPTIONAL)

## SPARK ARRESTER

In a dry or wooded area, it is recommendable to use the product with a spark arrester. Some areas require the use of a spark arrester. Please check your local laws and regulations before operating your product.

The spark arrester must be cleaned regularly to keep it functioning as designed.

A clogged spark arrester :

- Prevents the flow of exhaust gas
- Reduces engine output
- Increases fuel consumption
- Makes starting difficult

### [CAUTION]

If the engine has been running, the muffler and the spark arrester will be very hot. Allow the muffler to cool before cleaning the spark arrester.

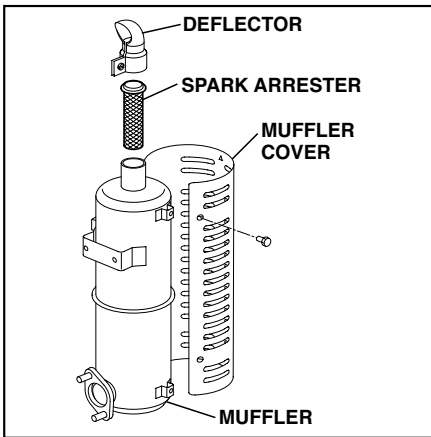

### How to remove the spark arrester

1. Remove the flange bolts from the muffler cover and remove the muffler cover.
2. Remove the special screw from the spark arrester and remove the spark arrester from the muffler.

### Clean the spark arrester screen

Use a brush to remove carbon deposits from the spark arrester screen. Be careful to avoid damaging the screen.

The spark arrester must be free of breaks and holes. Replace the spark arrester if it is damaged.

Install the spark arrester, and muffler protector in the reverse order of disassembly.

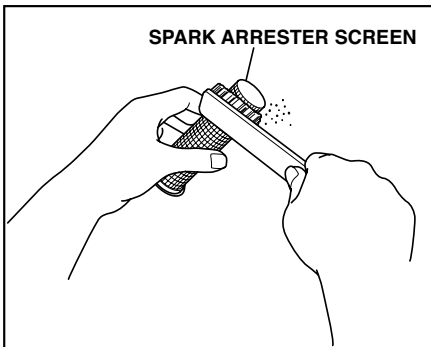

# 8. MAINTENANCE SCHEDULE

MAINTENANCE, REPLACEMENT, OR REPAIR OF EMISSION CONTROL DEVICES AND SYSTEMS MAY BE PERFORMED BY ANY NONROAD ENGINE REPAIR ESTABLISHMENT OR INDIVIDUAL.

## DAILY INSPECTION

Before running the engine, check the following service items.

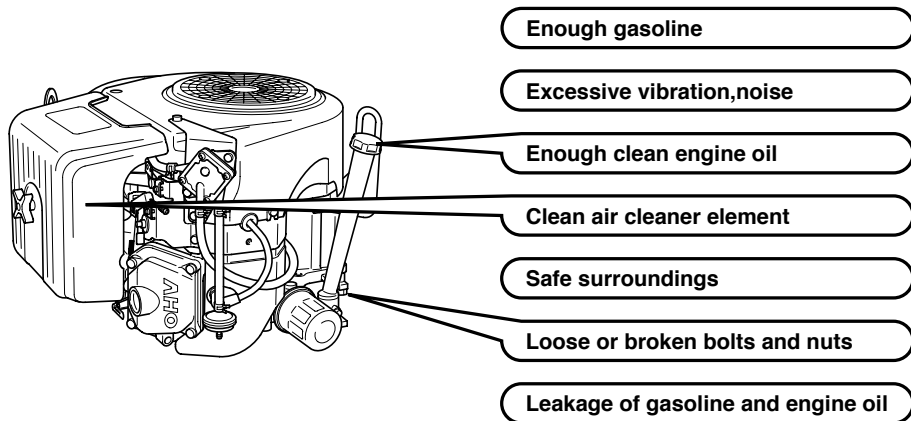

## PERIODIC MAINTENANCE

Periodic maintenance is vital to safe and efficient operation of your engine. Check the table below for periodic maintenance intervals.

**IT IS ALSO NECESSARY FOR THE USER OF THIS ENGINE TO CONDUCT THE MAINTENANCE AND ADJUSTMENTS ON THE EMISSION-RELATED PARTS LISTED BELOW TO KEEP THE EMISSION CONTROL SYSTEM EFFECTIVE.**

The emission control system consists of the following parts:

- |   |  |  |
|---|--|--|
| (1) Carburetor and internal parts               | (4) Air cleaner elements                       | (8) Exhaust manifold, if applicable          |
| (2) Cold start enrichment system, if applicable | (5) Spark plug                                 | (9) Hoses, belts, connectors, and assemblies |
| (3) Intake manifold, if applicable              | (6) Magneto or electronic ignition system      |  |
|   | (7) Spark advance/retard system, if applicable |  |

The maintenance schedule indicated in the following table is based on the normal engine operation. Should the engine be operated in extremely dusty condition or in heavier loading condition, the maintenance intervals must be shortened depending on the contamination of oil, clogging of filter elements, wear of parts, and so on.

## Periodic Maintenance Schedule table

Maintenance Items	Every 8 hours (Daily)	Every 50 hours	Every 200 hours	Every 500 hours	Every 1000 hours
Clean engine and check bolts and nuts	● (Daily)				
Check for leakage from hoses and fitting	● (Daily)				
Check and refill engine oil	● (Refill daily to upper level)				
Change engine oil (*Note 1)	● (Initial 20 hours)	● (Every 100 hours)			
Replace engine oil filter (*Note 1)	● (Initial 20 hours)		●		
Check battery electrolyte fluid level		●			
Clean spark plug		●			
Clean air cleaner		●			
Replace air cleaner element			●		
Clean fuel strainer			●		
Clean and adjust spark plug and electrodes			●		
Replace spark plug				●	
Spark arrester (optional part)		● (Every 100 hours)			
Remove carbon from cylinder head				●	
Clean and adjust carburetor				●	
Clean engine base (oil pan)				●	
Check and adjust valve clearance				●	
Replace fuel lines					● (Every 2 years)
Overhaul engine (*Note 2)					●

\*Note 1 : Initial oil change and oil filter replacement should be performed after 20 hours of operation.

Thereafter change oil every hundred (100) hours and replace oil filter 200 hours. Before changing oil, check for a suitable way to dispose of old oil. Do not pour it down into sewage drains, onto garden soil or into open streams. Your local zoning or environmental regulations will give you more detailed instructions on proper disposal.

\*Note 2 : As to the procedures, please refer to the Service Manual or consult your nearest service dealer.

\*Note 3 : More frequent oil changing, oil filter replacement and air cleaner service on replacement may be necessary depending on operating conditions. This would include dusty environment, high ambient temperature, heavy engine loading.

# 9. "HOW-TOW" MAINTENANCE

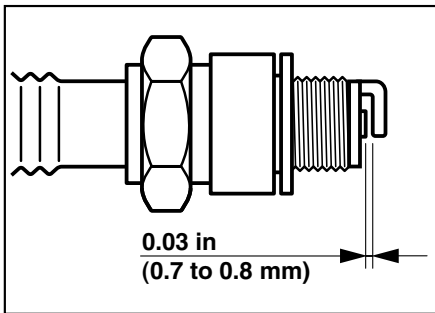

## INSPECTING THE SPARK PLUG

- Clean off carbon deposits on the spark plug electrode using a plug cleaner or wire brush.
- Check electrode gap.  
Adjust gap to : 0.03 inches (0.7mm to 0.8mm)
- Use a proper spark plug :  
**BP6ES : NGK**  
**(N9YC : CHAMPION)**

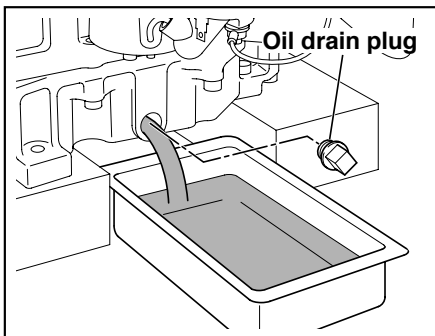

## ENGINE OIL CHANGE

- Initial oil change  
· · · · · After 20 hours of operation
- Thereafter  
· · · · · Every 100 hours of operation

1. When changing oil, stop the engine and loosen the drain plug.
2. Re-install the drain plug before refilling oil.
3. Refer to the recommended oil table on page 5.
4. Always use the best grade and clean oil. Contaminated oil, poor quality oil and shortage of oil cause damage to engine or shorten the engine life.

**OIL CAPACITY : 2.0 L**

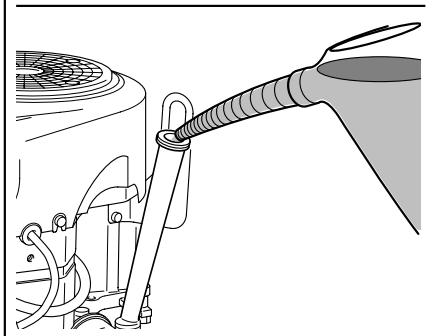

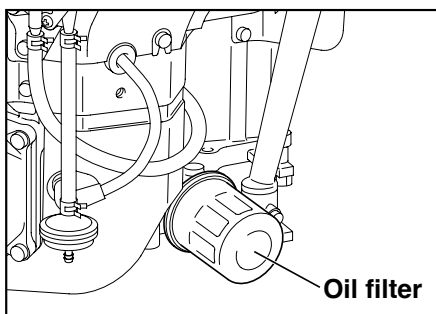

### **CAUTION**

To prevent injury, pay attention to the spilled hot engine oil when replacing engine oil filter.

## **ENGINE OIL FILTER REPLACEMENT**

- Initial engine oil filter replacement should be performed after 20 hours of operation. Thereafter replace the engine oil filter every 200 hours.
- When installing new engine oil filter, apply oil to O-ring, attach the oil filter in position and tighten 3/4 turns by hand or with wrench after touching the O-ring to the sealing surface of engine.
- After engine running for a while, make sure to check no oil leakage around the oil filter.

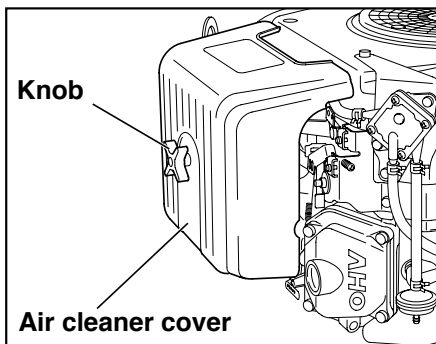

## **CLEANING AIR CLEANER**

Dirty air cleaner element will cause starting difficulty, power loss, engine malfunctions, and shorten engine life extremely.

Keep the air cleaner element always clean.

Air cleaner paper element and urethane form can be take out after removing knob and air cleaner cover. When installing, set the paper element and urethane form on the air cleaner base. Be sure to check the grommet is in position, and then install the cover with knob tightened securely.

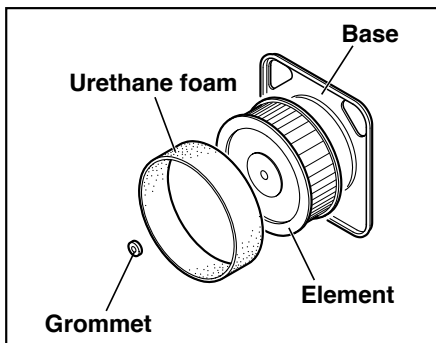

- Urethane Form cleaning  
Wash and clean the urethane form in kerosene. Saturate in a mixture of 3 parts kerosene and 1 part engine oil, and then squeeze to remove excess oil. Clean urethane form every 50 hours.

#### ■ Paper element

Clean by tapping gently to remove dirt and blow off dust. Never use oil. Clean paper element every 50 hours of operation, and replace element every 200 hours.

### **CLEAN COOLING SYSTEM**

Grass, chaff or dirt may clog the rotating screen and the air cooling system after prolonged service.

Before each use check the rotating screen and clean grass and debris if necessary.

Yearly or every 100 hours, whichever occurs first, remove the rotating screen, blower housing, cylinder baffle and head cover and clean the cooling fins to avoid overheating and engine damage.

### **CHECKING BOLTS, NUTS AND SCREWS**

Retighten loose bolts and nuts.

Check for fuel and oil leaks.

Replace damaged parts with new ones.

Keep safety in your mind.

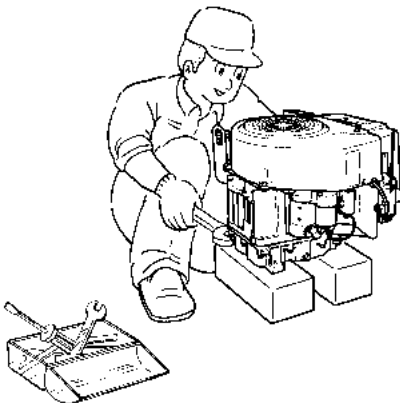
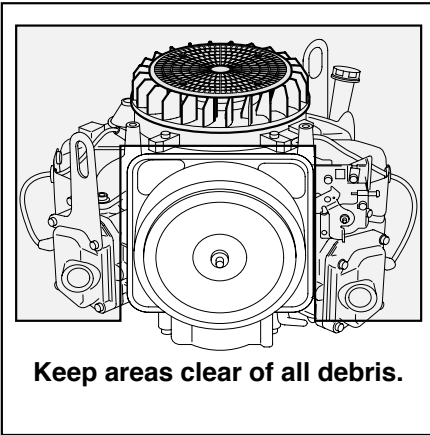



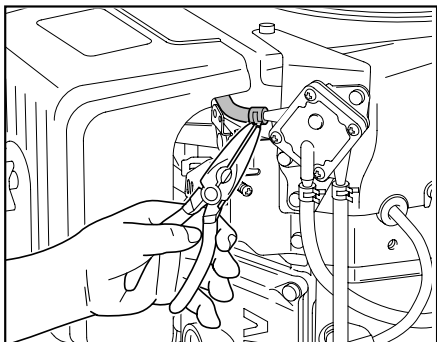

## FUEL HOSE REPLACEMENT

### **WARNING**

Take extreme caution when replacing fuel hose ; gasoline is flammable.

Replace the fuel hose every 1,000 hours or every 2 years.

If fuel hose leak is found, replace the fuel hose immediately.

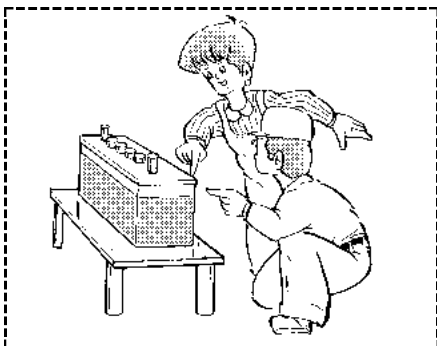

## CHECKING BATTERY

### **WARNING**

Battery electrolyte is poisonous and acid.

Serious injury results from contact with the skin, eyes or clothing.

If the electrolyte fluid is below level line, refill battery with distilled water.

## HIGH ALTITUDE ENGINE OPERATION

- Please have an authorized SUBARU Industrial Power Products dealer modify this engine if it is to be run continuously above 5,000 feet (1,500 meters). Failure to do so, may result in poor engine performance, spark plug fouling, hard starting, and increased emissions.
- Carburetor modification by an authorized SUBARU Industrial Power Products dealer will improve performance and allow that this engine meets EPA (Environmental Protection Agency) and California ARB (Air Resources Board) emission standards throughout its useful life.
- An engine converted for high altitudes can not be run at 5,000 feet or lower. In doing so, the engine will overheat and cause serious engine damage. Please have an authorized SUBARU Industrial Power Products dealer restore high altitude modified engines to the original factory specification before operating below 5,000 feet.

# 10. PREPARATIONS FOR STORAGE

## DISCHARGE FUEL (NO SMOKING !)

### WARNING

Take extreme caution when draining ; gasoline is flammable.

Drain fuel from fuel tanks, carburetor and fuel line.

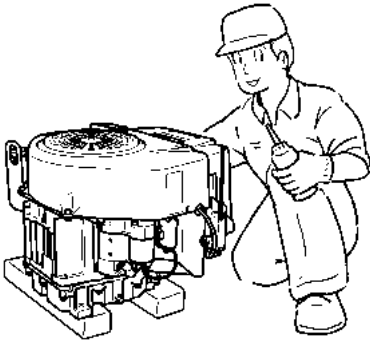

## ENGINE OIL

- Change the engine oil with fresh oil.
- Remove the spark plug, pour about 5 cc of engine oil into the cylinder, slowly start the engine for 2 or 3 seconds, and re-install the spark plug.

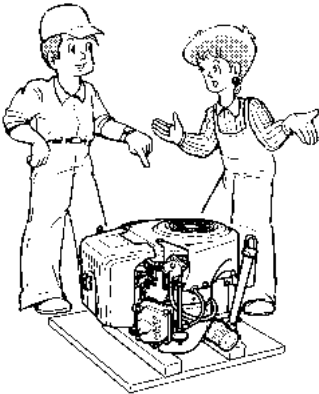

## CLEAN AND STORE

- Slowly turn the crankshaft until resistance is felt and leave it in that position.
- Clean the engine thoroughly with an oiled cloth, put the cover on, and store the engine indoors in a well-ventilated, low humidity area.

# 11. SPECIFICATIONS

MODEL	EH63V	EH65V
Type	Air-Cooled, 4-Stroke, V-Twin Cylinder, Vertical P.T.O. shaft, OHV Gasoline Engine	
Bore x stroke	2-80 mm x 65 mm (31.5 in x 25.6 in)	
Displacement	653 cm <sup>3</sup> (39.8 cu in.)	
Maximum Output kW (HP) / rpm	13.4 (18.0) / 3600	16.4 (22.0) / 3600
Max. Torque N•m (kgf•m)/ rpm	43.3 (4.41) / 2000	45.6 (4.65) / 2500
Direction of Rotation	Counterclockwise as viewed from P.T.O. shaft side	
Lubricant	Automotive Engine Oil SAE #20, #30 or 10W-30 ; Class SE or higher (SG, SH or SJ is recommended)	
Capacity of Lubricant	2.0 L (0.41 U.S. gal.)	
Fuel	Automotive Unleaded Gasoline	
Spark plug	NGK BP6ES (Champion N9YC)	
Starting System	Electric Starter	
Dry Weight	44 kg (97.0 lb.)	
Dimension (L x W x H)	386 mm x 513 mm x 531 mm (15.2 in x 20.2 in x 20.9 in)	
Valve Clearance (Intake & Exhaust)	0.0039 ± 0.0012 in (0.1 ± 0.03 mm) Note : Adjust the valve clearance while the engine is cold.	
Emissions Durability Period	—	1000 hours

• Specifications are subject to change without notice

---

**ISSUE EMD-EU7285**



**SUBARU**

**FUJI HEAVY INDUSTRIES LTD.  
INDUSTRIAL PRODUCTS COMPANY**

4-410 ASAHI, KITAMOTO-SHI, SAITAMA, 364-8511, JAPAN  
TEL: +81-48-593-7798 FAX: +81-48-593-7946  
<http://www.subaru-robin.jp>

PRINTED IN JAPAN  
December 2011

---