

Installation/Operation/Maintenance

Applies to: **Models RIH, RIHV, RIHVN, and RIHVL**
Gas-Fired High-Intensity Infrared Heaters



Model RIH

WARNING

Improper installation, adjustment, alteration, service or maintenance can cause serious property damage, injury, or death. Read these instructions thoroughly before installing or servicing this equipment.

WARNING

Gas-fired appliances are not designed for use in hazardous atmospheres containing flammable vapors or combustible dust, or atmospheres containing chlorinated or halogenated hydrocarbons. See Hazard Intensity Levels, page 2.

FOR YOUR SAFETY

If you smell gas:

1. Open Windows
2. Don't touch electrical switches
3. Extinguish any open flame
4. Immediately call your gas supplier.

The use and storage of gasoline or other flammable vapors and liquids in the vicinity of this appliance is hazardous.

Table of Contents

<p>1.0 General 2-4</p> <p> 1.1 Hazard Labels and Notices2</p> <p> 1.2 General Information.....2</p> <p> 1.3 Warranty3</p> <p> 1.4 Installation Codes3</p> <p>2.0 Location 4-5</p> <p> 2.1 Recommended Mounting Height and Distance from a Wall4</p> <p> 2.2 Ventilation Requirements.....5</p> <p>3.0 Receiving 5</p> <p>4.0 Dimensions and Clearances 6-7</p> <p> 4.1 Dimensions.....6</p> <p> 4.2 Clearances.....6</p> <p>5.0 Suspending the Unit. 7-9</p> <p>6.0 Gas Supply 9-10</p> <p> 6.1 Gas Supply Line.....9</p> <p> 6.2 Gas Pressure10</p>	<p>7.0 Electrical 10-13</p> <p> 7.1 Electrical Supply10</p> <p> 7.2 Electrical Requirements by Voltage and Control Types 11</p> <p> 7.3 Wiring Diagrams12</p> <p>8.0 Ignition and Operation 14</p> <p>9.0 Commissioning and Startup 15</p> <p>10.0 Accessories 16</p> <p>11.0 Maintenance and Service 17-19</p> <p> 11.1 Maintenance Procedures17</p> <p> 11.2 Troubleshooting Guide.....18</p> <p>Index 19</p> <p>INSTALLATION RECORD 20</p>
--	---

1.0 General

1.1 Hazard Labels and Notices

There are warning labels on the heater and throughout this manual. For your safety, read the definitions below and comply with all boxes labeled CAUTION, WARNING, and DANGER during installation, operation, maintenance, and service.

HAZARD INTENSITY LEVELS

- 1. DANGER: Failure to comply will result in severe personal injury or death and/or property damage.**
- 2. WARNING: Failure to comply could result in severe personal injury or death and/or property damage.**
- 3. CAUTION: Failure to comply could result in minor personal injury or death and/or property damage.**

1.2 General Information

Model RIH/RIHV infrared heaters are designed and manufactured in compliance with the American National Standards Institute. They are design-certified by the Canadian Standards Association to ANSI Standards for installation in the United States and to CAN/CSA Standards for installation in Canada. These units are approved for indoor commercial and industrial installation only. Installation should be done by a qualified agency in accordance with these instructions and in compliance with all codes and requirements of authorities having jurisdiction.

DANGER

These infrared heaters are operated without venting. Comply with ventilation requirements in Paragraph 2.2, page 5.

Model RIH and RIHV series heaters **SHOULD NOT BE USED** in the following applications:

- Enclosed swimming pool areas
- Areas with contaminated atmospheres
- Outdoor applications
- Residential applications
- Areas requiring explosion-proof equipment
- Process heating applications

Infrared heaters should not be installed in buildings with uninsulated metal roof decks. Uninsulated metal roof decks will cause condensation of water vapor (contained in the unvented heater flue gas) on the inside of the building. Metal roof decks must be insulated using built-up insulation and roofing on the exterior or inside insulation that is not permeable to water vapor. Interior insulation that is permeable to water vapor must be completely sealed with a vapor barrier.

High Altitude

Heaters are manufactured for use at the specific altitude range stated on the heater rating plate. Do not install a heater that is not rated for the correct altitude.

1.3 Warranty

WARRANTY IS VOID IF.....

- Unit is used in atmosphere containing flammable vapors; atmosphere containing chlorinated or halogenated hydrocarbons; or atmosphere containing explosive dust.
- Unit is installed without proper clearance to combustible materials or in a location where the heater controls can be subjected to ambient temperatures in excess of 150°F (66°C) or below -40°F (-40°C).
- Unit is installed at an angle not approved for that model.
- Unit is installed for other than space heating application. **NOTE:** Use of this heater for processing applications voids the certification and the warranty.
- Unit is installed for residential use. This heater is NOT for residential use.
- Unit is installed outdoors.
- Unit is installed in an enclosed swimming pool area.
- Unit is altered. Units are completely factory assembled and tested.

1.4 Installation Codes

These units must be installed in accordance with local building codes. In the absence of local codes, in the United States, the unit must be installed in accordance with the National Fuel Gas Code ANSI Z223.1/NFPA 54 (latest edition). A Canadian installation must be in accordance with the CAN/CSA B149.1, Natural Gas and Propane Installation Code. These codes are available from CSA Information Services, 1-800-463-6727. Local authorities having jurisdiction should be consulted before installation is made to verify local codes and installation procedure requirements.

All electrical wiring including electrical grounding must be in accordance with the National Electric Code ANSI/NFPA No. 70 (latest edition) or, in Canada, the Canadian Electrical Code, Part I and Part II, CAN/CSA C22.1.

The installing contractor must be familiar with all of the various requirements and is responsible for installing the heater in compliance with the applicable codes.

Aircraft Hangars: In the United States, the heaters must be installed in accordance with ANSI/NFPA 409 (latest edition). Publications are available from the National Fire Protection Association, Batterymarch Park, Quincy, MA 02269. In Canada, installations in an aircraft hangar must comply with CAN/CSA-B149.1. Both the ANSI/NFPA 409 (latest edition) and the CAN/CSA-B149.1 (latest edition) specify that the heater shall not be located in an area of an aircraft hangar where it may be subjected to physical damage by aircraft, cranes, moveable scaffolding, or other objects.

NFPA 409 (latest edition) specifies a clearance of 10 feet (3M) to the bottom of the heater from the highest surface of the wings or engine enclosures of the highest aircraft which may be housed in the hangar. The measurement shall be made from the wing or engine enclosure, whichever is higher from the floor, to the bottom of the heater.

CAN/CSA-B149.1 (latest edition) specifies that a heater located in an aircraft storage or servicing area shall be installed so that no portion of an aircraft that can occupy the area is within the "clearance to combustible material" as marked on the heater rating plate.

Both NFPA 409 (latest edition) and CAN/CSA-B149.1 (latest edition) specify a minimum clearance of eight feet (2.5M) from the floor to the heater in other sections, such as offices or shops, that communicate with the aircraft hangar.

Special Space Heating Installations

1.0 General (cont'd)

1.4 Installation Codes (cont'd)

Special Space Heating Installations (cont'd)

Repair Garages - U.S.: In the United States, heaters installed in public garages must be in accordance with the Standard for Motor Fuel Dispensing Facilities and Repair Garages, NFPA 30A (latest edition) (Formerly the Standard for Repair Garages (NFPA 88B). Heat producing appliances using gas or oil fuel listed for use in garages shall be permitted to be installed in lubrication rooms, service rooms, or fuel dispensing areas where Class I liquids are dispensed or transferred, provided the equipment is installed at least 8 ft (2.4M) above the floor.

Parking Structures - U.S. - These overhead heaters are suitable for use in parking structures when installed in accordance with the Standard for Parking Structures, NFPA 88A (latest edition). All flames associated with the heating equipment shall be located a minimum of 18 inches (500mm) below the floor-ceiling assembly or 18 inches (500mm) above the floor.

Garages - Canada - In Canada, these overhead heaters are suitable for use in garages when installed in accordance with the Canadian Natural Gas and Propane Installation Code, CAN/CSA B149.1 (latest edition). The minimum clearance from the radiant face of the infrared heater to the upper surface of the highest vehicle shall not be less than the certified clearance from combustible material as indicated on the heater (installed in a garage or a car wash). Provision shall be made to maintain these minimum specified clearances by an interlock that shuts off the gas supply until the required clearances have been re-established, a protective bar, or a device that provides a warning when the clearances are not being maintained. Where an infrared heater is installed in a garage and the clearance from combustible material cannot be maintained when the vehicle is raised on a hoist, an electrical interlock shall be provided to shut off the burner and prevent its operation until the required clearance has been re-established.

2.0 Location

2.1 Recommended Mounting Height and Distance from a Wall

NOTE: Clearances to combustibles must be observed; see Paragraph 4.2.

Heaters should be located with respect to building construction and equipment to provide accessibility for servicing and cleaning.

Do not angle the heater more than 30°. Unit must be level.

Recommended Mounting Height (feet and meters)

Lower mounting height may be used if personnel are not kept directly under the heater.

Model	With Standard Reflector				With Parabolic Reflector, Option DM2			
	at 5° Angle		at 30° angle		at 5° Angle		at 30° angle	
	ft	M	ft	M	ft	M	ft	M
RIHN 30	11.0 - 13.0	3.4 - 4.0	10.0 - 12.0	3 - 3.7	N/A		N/A	
RIHL 50	13.5 - 15.5	4.1 - 4.7	12.5 - 14.5	3.8 - 4.4	15.5 - 18.5	4.7 - 5.6	14.0 - 17.0	4.3 - 5.2
RIHN 60	14.5 - 16.5	4.4 - 5.0	13.0 - 15.0	4.0 - 4.6	16.0 - 20.0	4.9 - 6.1	15.0 - 18.0	4.6 - 5.5
RIHVL 90	16.0 - 18.5	4.9 - 5.6	14.5 - 17.0	4.4 - 5.2	19.5 - 22.5	5.9 - 6.9	17.5 - 20.5	5.2 - 6.2
RIHVN 100	17.0 - 19.5	5.2 - 5.9	15.0 - 17.5	4.6 - 5.3	20.5 - 23.5	6.2 - 7.2	18.5 - 21.5	5.6 - 6.6
RIHVL 120	17.5 - 21.0	5.3 - 6.4	15.5 - 18.5	4.7 - 5.6	21.5 - 25.0	6.6 - 7.6	20.0 - 23.0	6.1 - 7.0
RIHVN 150	18.5 - 22.5	5.6 - 6.9	16.5 - 20.0	5.0 - 6.1	24.0 - 27.5	7.3 - 8.4	21.5 - 24.5	6.6 - 7.5
RIHVN 160	19.0 - 23.0	5.8 - 7.0	17.0 - 20.5	5.2 - 6.2	25.0 - 28.5	7.7 - 8.7	22.5 - 25.5	6.9 - 7.8
RIHVN 200	20.5 - 25.0	6.2 - 7.6	18.5 - 22.5	5.6 - 6.9	27.0 - 31.0	8.2 - 9.4	24.5 - 28.0	7.5 - 8.5

Recommended Distances (feet and meters) for Units Mounted at a 5° Angle

Applies to Units Mounted at a 5° Angle	Distance from the Wall		Maximum Distance Between Heater Rows
	With Standard Reflector	With Parabolic Reflector, Option DM2	
RIHN 30	8 ft (2.4M)	5 ft (1.5M)	90 ft (27.4M)
RIHL 50 & RIHN 60	12 ft (3.7M)	9 ft (2.7M)	100 ft (30.5M)
RIHVL 120	18 ft (5.5M)	14 ft (4.3M)	115 ft (35.1M)
RIHVN 150	20 ft (6.1M)	15 ft (4.6M)	120 ft (36.6M)
RIHVN 160 & RIHVN 200	24 ft (7.3M)	20 ft (6.1M)	130 ft (39.6M)

2.2 Ventilation Requirements

WARNING

Insufficient ventilation may result in health problems, carbon monoxide poisoning, or death. Always vent enclosed spaces and buildings according to national, state, provincial, and local codes.

These heaters are the unvented type. Products of combustion generated are released into the space being heated. Sufficient ventilation of fresh air is required to provide adequate air for efficient combustion and to dilute and remove the products of combustion.

In the United States, the minimum intake and exhaust air openings shall provide for not less than 4 CFM per 1,000 BTUH (0.38m³ a minute per kW). In the United States, this may be accomplished by either gravity or mechanical means. Both exhaust fans and inlet air openings are required in tight buildings. Exhaust openings for removing flue products shall be above the level of the heater (ANSI Z223.1/NFPA 54, section 10.18, Infrared Heaters).

Air for combustion, ventilation, and dilution of flue gases shall be obtained by application of one of several methods described in the National Fuel Gas Code, ANSI Z223.1/NFPA 54, section 9.3, Air for Combustion and Ventilation.

The ventilation technical information outlined in the current ASHRAE Handbooks should be observed when locating vents. When mechanical means are provided to supply and exhaust, a positive interlock with the heater thermostat must be provided by the installer so that the heater cannot operate unless the supply and exhaust system is operating.

Mechanical exhaust fans are typically located at high points of the building. For flat roof areas, a series of small exhausters should be distributed over the roof areas and interlocked with various heating zones. Local codes may permit the use of humidistat control to remove water vapor and products of combustion. Humidistat settings will typically be in the 40 to 55% relative humidity range.

Fresh air intake openings are typically located high on the building sidewalls at or above the level of the heaters. One square inch of net free inlet area per 1,000 BTUH (22cm² per kW) is required. Multiple inlets, well distributed, should be used and should direct air upward to prevent drafts at floor level. Inlets are typically limited to 1 to 2 square feet (900-1800cm²) in size. **Total area required can be computed by dividing exhaust CFM by 500 feet per minute. (Total area required can be computed by dividing exhaust cubic meters per minute by 152 meters per minute.)**

In Canada, the Natural Gas and Propane Installation Code CAN/CSA B149.1 (latest edition) requires the use of mechanical ventilation. The heater shall be provided with mechanical ventilation for combustion and ventilation air:

- (1) that is so located that products of combustion from each heater are effectively removed outdoors;
- (2) that has a ventilation volume of at least 3 CFM per 1,000 BTUH (0.29m³ a minute per kW) for natural gas and 4 CFM per 1,000 BTUH (0.38m³ a minute per kW) for LP/propane; and
- (3) is sufficient to maintain the level of carbon dioxide at less than 5000 ppm measured 6 ft (2M) above the work area.

3.0 Receiving

Check for any damage that may have been incurred during shipment.

If damage is found, document the damage with the transporting agency and immediately contact your distributor. If you are an authorized Distributor, follow the FOB freight policy procedures provided by Thomas & Betts for this product.

4.0 Dimensions and Clearances

4.1 Dimensions

FIGURE 1 - Model RIH Dimensions - inches and (mm)

Dimensions - inches			
Size	A	B	C
30, 50, 60	15-5/16	16-5/8	14-5/8
90, 100	23-15/16	25-1/4	23-1/4
120, 150	32-9/16	33-7/8	31-7/8
160, 200	41-3/16	42-1/2	40-1/2
Dimensions - mm			
Size	A	B	C
30, 50, 60	389	422	371
90, 100	608	641	591
120, 150	827	860	810
160, 200	1046	1080	1029

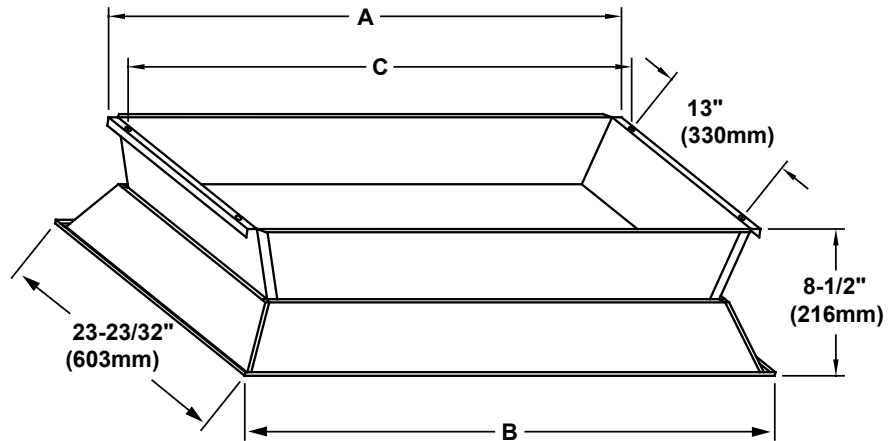

NOTE: Four (4) mounting holes 3/8" (9.5mm) diameter for balanced suspension are located by dimensions C x 13" (330mm).

4.2 Clearances

This heater model must be mounted with minimum clearances between the combustion surface and combustibles. The stated clearance to combustibles represents a surface temperature of 90°F (50°C) above room temperature. Building materials with a low heat tolerance (such as plastic, vinyl siding, canvas, tri-ply, etc.) may be subject to degradation at lower temperatures. It is the installer's responsibility to assure that adjacent materials are protected from degradation.

Locate the heater with respect to building construction and equipment so to provide sufficient clearance and accessibility for servicing and cleaning.

WARNING

Single or multi-heater placement must be such that continuous operation of the heater or heaters will not cause combustible materials or materials in storage to attain a temperature in excess of 150°F (66°C). See Hazard Levels, page 2.

WARNING

Under no circumstances should this heater be installed in a combustible atmosphere or in a location where the heater controls can be subjected to ambient temperatures in excess of 150°F (66°C). See Hazard Levels, page 2.

It is recommended that more distance than the minimum clearance be maintained above the unit whether or not the construction is combustible. This will reduce and/or eliminate hot spots and possible staining of painted ceiling surfaces. If the unit must be close to the roof or ceiling, interpose a non-combustible baffle (twice the size of the reflector) between the unit and the roof or ceiling. Allow at least 2" (52mm) between the roof or ceiling and the non-combustible baffle. Allow at least 12" (305mm) between the non-combustible baffle and the top of the heater.

To assure clearances to combustibles are maintained, signs **must** be posted specifying the maximum stacking height of material under and near the heater.

FIGURE 2 - Clearances to Combustibles (Inches and mm)

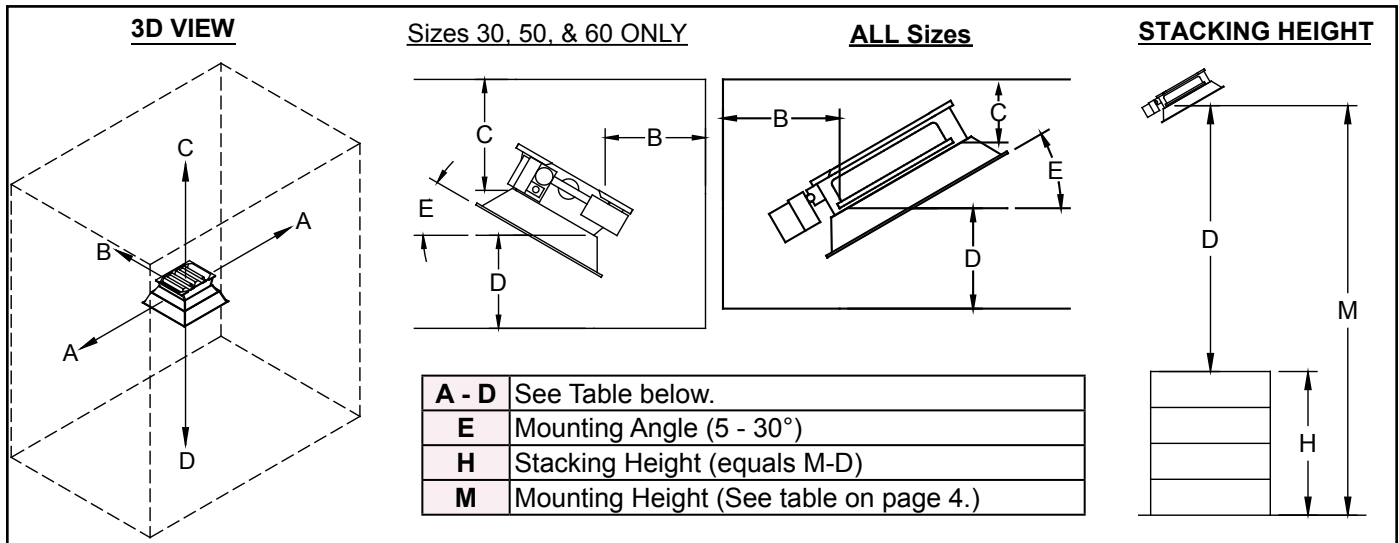

- In locations used for the storage of combustible materials, signs shall be posted to specify the maximum permissible stacking height to maintain required clearances from the heater to combustibles. (ANSI Z233.1/NFPA 54)
- The stated clearance to combustibles represents a surface temperature of 90°F (50°C) above room temperature. Building materials with low heat tolerance (such as plastic, vinyl siding, canvas, tri-ply, etc.) may be subject to degradation at lower temperatures. It is the responsibility of the installer to assure that adjacent materials are protected from degradation (ANSI Z83.19).
- It is recommended more distance than the minimum clearance be maintained above the unit whether or not the construction is combustible to reduce and/or eliminate hot spots and possible staining of painted ceiling surfaces.
- If the unit must be close to the roof or ceiling, interpose a non-combustible baffle (twice the size of the reflector) between the unit and the roof or ceiling. Allow at least 2" (5cm) between the roof or ceiling and the non-combustible baffle. Allow at least 12" (31cm) between the non-combustible baffle and the top of the heater.

CODE in FIGURE 2	Clearance to Combustibles	Natural Gas Models												Propane Models					
		RIHN 30 ^x		RIHN 60 ^y		RIHVN 100 ^z		RIHVN 150		RIHVN 160 ^z		RIHVN 200		RIHL 50 ^z		RIHVL 90 ^z		RIHVL 120 ^z	
		inches	mm	inches	mm	inches	mm	inches	mm	inches	mm	inches	mm	inches	mm	inches	mm	inches	mm
A	Side of Heater	30	762	30	762	36	914	46	1168	48	1219	48	1219	30	762	36	914	46	1168
B	Back of Heater	30	762	30	762	30	762	33	838	33	838	33	838	30	762	30	762	33	838
C	Top of Heater:																		
	Mounted 5-29° (no heat deflector)	60	1524	60	1524	62	1575	64	1626	68	1727	68	1727	60	1524	62	1575	64	1635
	Mounted 30° only (no heat deflector)	48	1219	48	1219	50	1270	58	1473	68	1727	68	1727	48	1219	50	1270	58	1473
D	Mounted 5-30° with Heat Deflector, Option DO2	34	864	34	864	38	965	N/A		N/A		N/A		34	864	38	965	N/A	
	Below the Heater:																		
D	Standard Reflector	80	2032	80	2032	105	2667	125	3175	140	3556	140	3556	80	2032	105	2667	125	3175
	With Parabolic Reflector, Option DM2	110	2794	110	2794	135	3429	165	4191	180	4572	180	4572	110	2794	135	3429	165	4191

NOTES: ^x Model RIHN 30 is not available in Canada. ^y Model RIHN 60 in Canada requires addition of a wire grid, Option DN2. ^z See allowable mounting angles in Paragraph 5.

5.0 Suspending the Unit

Before installing the unit, check the supporting structure to determine that it has sufficient load-carrying capacity to support the weight.

Mounting angle must be within the tolerance allowed.

Unit Weight and Allowable Mounting Angle

Model	RIHN 30	RIHL 50	RIHN 60	RIHVL 90	RIHVN 100	RIHVL 120	RIHVN 150	RIHVN 160	RIHVN 200
Net Wt - lbs (kg)	Single-Stage	24 (11)	24 (11)	24 (11)	34 (16)	34 (16)	44 (20)	44 (20)	56 (26)
	Two-Stage	--	--	--	42 (19)	42 (19)	53 (23)	53 (23)	66 (29.9)
Allowable Mounting Angle Tolerance	5° - 30°	5° - 30°	5° - 30°	5° - 30°	5° - 30°	5° - 30°	5° - 30°	5° - 30°	5° - 30°

5.0 Suspending the Unit (cont'd)

Be certain to check local codes for mounting requirements and permission to use flexible gas connectors. Local codes may require rigid mounting. It is recommended that either the piping or the mounting be flexible to prevent fatigue failure from vibration and/or thermal expansion.

Heaters may be mounted with an angle of 5-30°. Do not angle heaters more than 30°. Suspend the heater with the gas manifold located on the low end. (Exception: It is permissible to suspend single-burner Models RIHN30, RIHL50, and RIHN60 with the gas valve on the high end; see **FIGURE 3B**.)

FIGURE 3A - Rigid or Chain Suspension applies to all Sizes - Heater must be level.

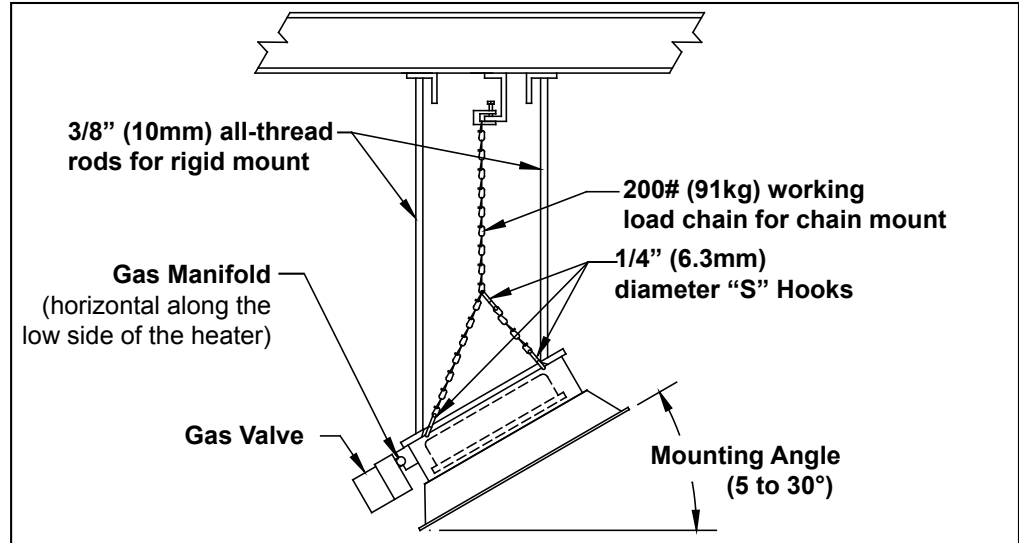
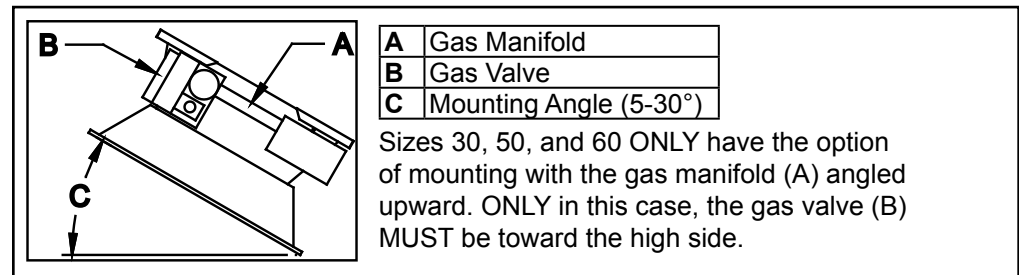

FIGURE 3B - Optional Mounting - applies only to Sizes 30, 50, and 60



For proper operation, the heater must be level.

If permissible by local code, it is recommended that the heaters be suspended with chain and "S" hook mounting. Chain with 200# (91kg) working load (1/0 Tenso) is recommended. "S" hooks must be a minimum 1/4" (6.3mm) diameter wire and must be closed after installation.

FIGURE 4 - Chain Hanging Instructions - Using either the chains and "S" hooks in Option UE1, chain and "S" hooks in Option UE2, or field-provided chain and "S" hooks

1. Securely attach long chains to overhead building structure with "S" hooks (A).
2. Attach the other end of the long chains to the back of the heater with "S" hooks (B).
3. Attach one end of the 11" (279mm) length chains to the front of the heater with S hooks (C). Attach the other end of the short chains to the long chains with "S" hooks (D) by placing the "S" hooks (D) in a loop of the long chain.
4. Check degree of angle mounting. Adjust the mounting angle by moving "S" hooks (D) of the short chains along the length of the long chains..
5. Check to be sure unit is level. Crimp all "S" hooks closed (A, B, C, and D).

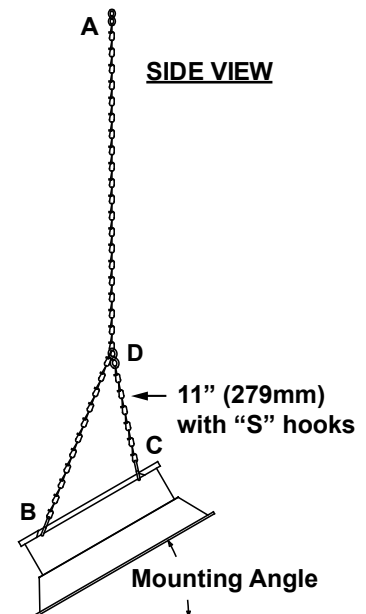

If a heater is located in an aircraft hangar or near overhead doors, it should be rigidly mounted to prevent swinging.

The installer is responsible for suspension of the heater. **Under no circumstances should either the gas supply line or electrical supply line to the unit be used to provide assistance in suspension. Do not run any gas or electric service lines above or below the heater or near the path of the flue products.**

6.0 Gas Supply

6.1 Gas Supply Line (Refer to FIGURE 6.)

WARNINGS

**DO NOT install any gas piping in heat zones.
DO NOT use gas supply piping to support the heater.**

- All piping must be installed according to local codes. Use new clean pipe. Inspect and clean out any chips or debris before installing the pipe and fittings.
- Piping joint compound must be resistant to the action of liquefied petroleum gases.
- An agency-approved flexible connection between the supply line and the heater may only be used if permitted by local code. It is recommended that either the piping or the mounting be flexible to prevent fatigue failure from vibration and/or thermal expansion.
- A first-stage pressure regulator is required when gas supply pressure exceeds 14" (35cm) w.c. If a pressure regulator is required, be sure that it is installed in the gas line with the arrow indicating gas flow pointing in the proper direction.
- An over-pressure protection device may be required in some jurisdictions.
- Install a 6" (152mm) drip-leg trap at the inlet connection.
- Install a 1/8" (32mm) NPT plugged tap, accessible for text gauge connection immediately upstream of the gas supply connection to the heater.
- Do not subject gas pressure regulators, flex connectors, and gas cocks on the heater to test pressures over 14" w.c. while checking supply piping for leaks.

CAUTION: Isolate the heater from the gas supply line during high pressure leak testing of gas supply piping.

- All piping joints must be tested for leaks with a non-corrosive leak detecting solution.
- Always use two wrenches when mating pipe connections to the heater. Excessive torque on the manifold may misalign gas orifices causing heater to malfunction.
- Purge all gas supply lines of air completely before attempting to ignite the heater.

WARNING

All components of a gas supply system must be leak tested prior to placing equipment into service. Use a non-corrosive leak detecting solution. Never test for leaks with an open flame. See Hazard Levels, page 2.

**FIGURE 5 -
Gas Supply
Connections -
All components
upstream of the
gas valve on the
unit are field-
supplied.**

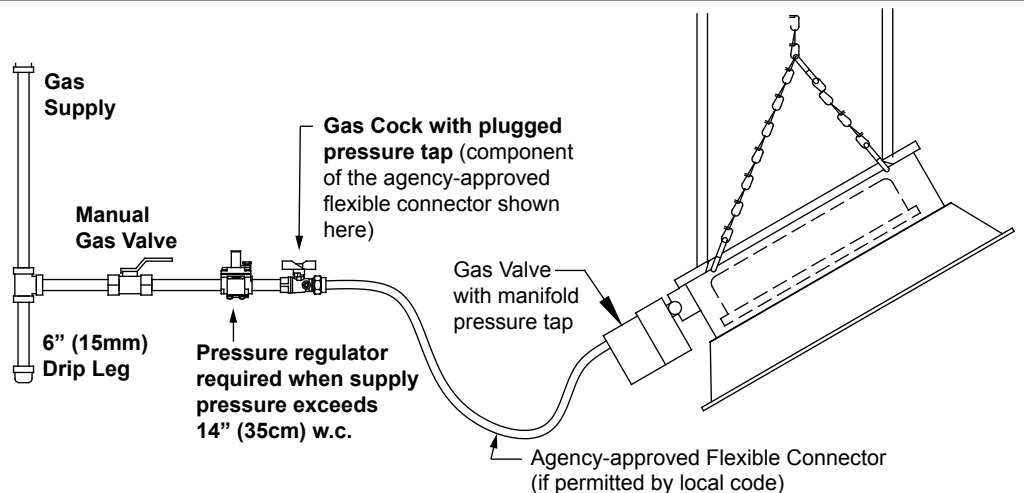

6.0 Gas Supply (cont'd)

6.2 Gas Pressure

The main supply line pressure must be limited to 14" w.c. If the line pressure can go above 14" w.c. (1/2 p.s.i.) at any time, a separate positive lockup, high-pressure type, service regulator must be used. Always check local codes for gas venting requirements for high-pressure regulators. High-pressure regulators will NOT turn off the flow of gas. The minimum supply line pressure at the inlet to the heater regulator must, in no case, be lower than 7" w.c. pressure for natural gas and 11" w.c. pressure for LP gas.

Gas Pressure Requirements			
Type	Supply Pressure (w.c)		Manifold Pressure (at the pressure tap in the gas valve)
	Minimum	Maximum	
Natural Gas	7 inches (18cm):	14 inches (35cm)	6 inches (15cm)
Propane	11 inches (28cm)	14 inches (35cm)	10 inches (25cm)

Use a water or red oil manometer when checking gas pressure. Do not use a dial gauge. All measurements must be made when this heater and all other gas burning equipment are operating at maximum capacity.

Natural gas models are orificed for 1000 BTU per cubic ft of gas. Propane models are orificed for 2500 BTU per cubic ft of gas.

7.0 Electrical

7.1 Electrical Supply

WARNINGS
The heater must be electrically grounded in accordance with the National Electric Code, ANSI/NFPA 70-latest edition, or the Canadian Electrical Code, CSA C22.1-latest edition.
Electrical supply lines shall NOT be used to support the heater.
Do not run electrical wiring above the heater or in direct view of radiant heat.

A heater or group of heaters can be controlled by a thermostat or manual switch. Total load of all heaters must be considered in determining the required contact rating of the controlling thermostat or switch.

General Requirements

- The electrical supply wiring to the heaters using 120 VAC or 24 VAC must be installed in accordance with local codes or the National Electric Code, ANSI/NFPA 70-latest edition.
- **IMPORTANT!** The electrical power supply **MUST** be properly grounded and properly polarized. The heater controls are extremely polarity sensitive and the heater will cycle on and off erratically if the electrical supply is not wired correctly. Have a qualified electrician check that the electrical supply circuit is properly grounded and that the electrical supply polarity is correct.
- The following types of grounding are **NOT** permitted by code: grounding to building structures, grounding to electrical conduit, grounding to gas pipelines, or grounding to water pipelines.
- Electrical power supply must be connected to a circuit breaker or to a separately fused circuit with a disconnect.
- Neither thermostats, nor switches, nor field wiring are supplied as standard equipment. When a thermostat is used to control the temperature of the heated zone, follow the wiring diagram on the unit. Position the thermostat according to the manufacturer's instructions.
- **Important:** In the event of an electrical fault after installation of the appliance, preliminary system checks are required to be carried out, i.e. ground continuity, polarity and resistance to ground, by a trained and qualified electrician.
- Make electrical connection to the heater as shown in **FIGURE 6A, 6B, or 6C.**

7.2 Electrical Requirements by Voltage and Control Types

More specific electrical requirements may vary depending on whether the unit is single-stage (115V), single-stage (24V), or two-stage (24V). Select the information that applies to the unit being installed.

NOTES common to FIGURES 6A, 6B, and 6C (page 12):

- * Mechanical ventilation interlock is required when all combustion air is provided by a mechanical air supply system.
- #10 ring terminal is required for ground service conductor (by others) to attach to green ground screw on heater.
- The heater control is extremely polarity sensitive and the heater will cycle on and off erratically if the electrical supply is not wired correctly. Have a qualified electrician check that the electrical supply circuit is properly grounded and that the electrical supply polarity is correct.
- All components and wiring illustrated are field-supplied.

FIGURE 6A - With 120 VAC DIRECT SPARK IGNITION (DSI) SINGLE-STAGE CONTROLS

- Electrical supply: 120 VAC - 60 Hz - 1 Phase.
- Maximum total heater current draw: 0.14 Amps.
- Total heater power consumed: 16.8 VA (16.8W).
- 3-wire field service required.
- Field wiring having a minimum temperature rating of at least 302°F (150°C) shall be used and supply circuit wiring shall have a minimum size of 16 AWG (1.0mm²).

120 VAC DSI HEATER ELECTRICAL SUPPLY AND THERMOSTAT WIRING*

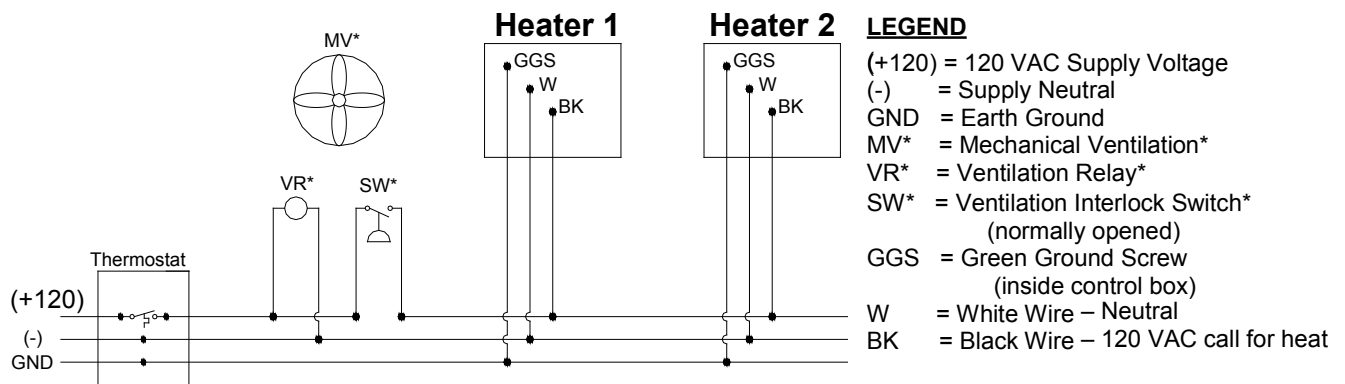
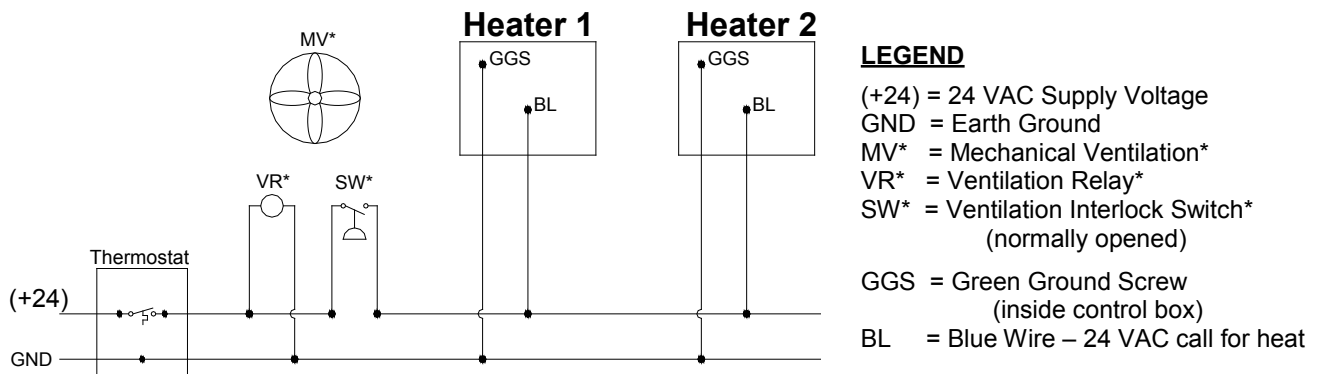

FIGURE 6B - With 24 VAC DIRECT SPARK IGNITION (DSI) SINGLE-STAGE CONTROLS

- Electrical supply: 24 VAC - 60 Hz or 50 Hz - 1 Phase.
- Maximum total heater current draw: 0.66 Amps.
- Total heater power consumed: 15.9 VA (15.9W).
- 2-wire field service required.
- Field wiring having a minimum temperature rating of at least 302°F (150°C) shall be used and supply circuit wiring shall have a minimum size of 16 AWG (1.0mm²).

24 VAC DSI SINGLE-STAGE HEATER ELECTRICAL SUPPLY AND THERMOSTAT WIRING*



7.0 Electrical (cont'd)

7.2 Electrical Requirements by Voltage and Control Types (cont'd)

FIGURE 6C - With 24 VAC DIRECT SPARK IGNITION (DSI) 2-STAGE CONTROLS (Option AG2R on RIHV100, RIHVN150, and RIHVN200 only)

- Electrical supply: 24 VAC - 60 Hz or 50 Hz - 1 Phase.
- Maximum total heater current draw: 0.96 Amps.
- Total heater power consumed: 23.1 VA (23.1W).
- 3-wire field service required to 2-stage thermostat. 4-wire thermostat cable required from thermostat to heater.
- Field wiring use 18/4 [18 AWG (0.8mm²)/4-conductor] solid class 2 thermostat cable having a minimum insulation temperature of 140°F (60°C) between thermostat and heater. Maximum length is 125 feet (38m).

24 VAC DSI 2-STAGE HEATER ELECTRICAL SUPPLY AND THERMOSTAT WIRING*

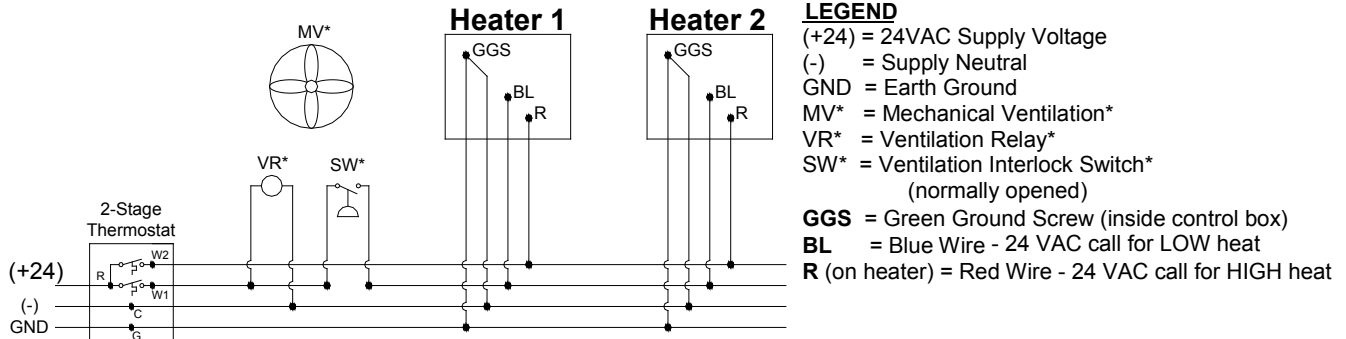

Use 18/4 solid class 2 thermostat cable between heater and thermostat with a maximum length of 125 feet (38m).

7.3 Wiring Diagrams

FIGURE 7A - 120 VAC Direct Spark Ignition Electrical Connection Diagram

120 VAC – 60 Hz – 1 Phase
 Heater Maximum Current Draw = 0.14 Amps.
 Total Heater Power Consumed = 16.8 VA

Wire Colors
 BK = Black
 G = Green
 O = Orange
 R = Red
 W = White
 Y = Yellow

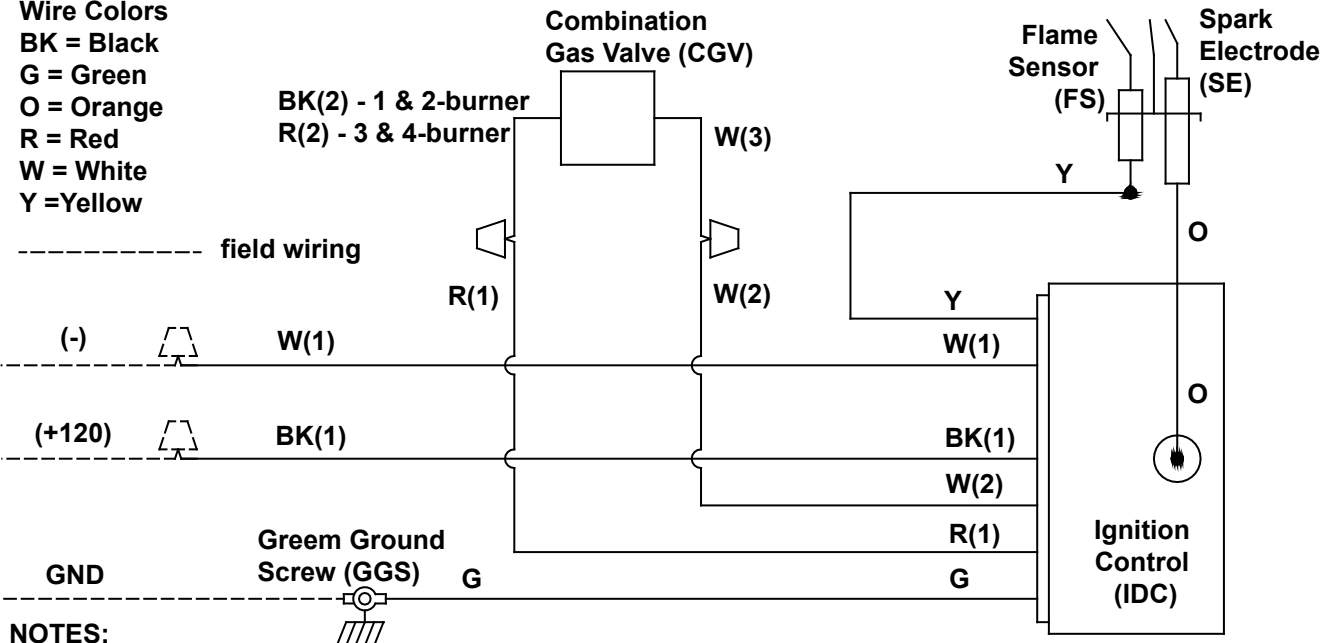

NOTES:

- Control is polarity sensitive.
- Installer to provide and install #10 ring terminal required for ground service conductor to attach to green ground screw in heater control box.
- See Paragraphs 7.1 and 7.2 for detailed information on electrical supply and thermostatic control.
- If any of the original wire as supplied with the appliance must be replaced, it must be replaced with wiring material having a temperature rating of at least 302°F (150°C) and a minimum size of 16 AWG (1.0mm²).

**FIGURE 7B - 24 VAC SINGLE-STAGE
DIRECT SPARK IGNITION ELECTRICAL
CONNECTION DIAGRAM**

**24 VAC – 60 or 50 Hz – 1 Phase
Heater Maximum Current Draw = 0.66 Amps.
Total Heater Power Consumed = 15.9 VA**

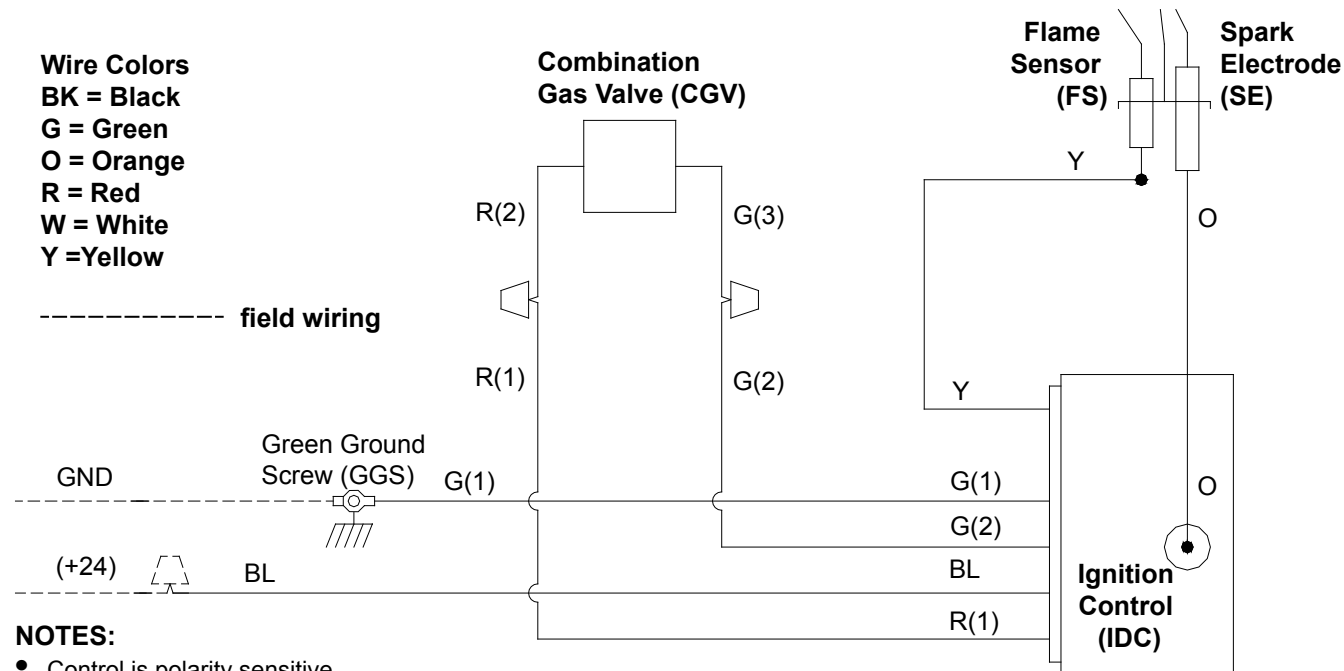

**FIGURE 7C - 24 VAC 2-STAGE DIRECT
SPARK IGNITION ELECTRICAL
CONNECTION DIAGRAM**

**24 VAC – 60 or 50 Hz – 1 Phase
Heater Maximum Current Draw = 0.96 Amps.
Total Heater Power Consumed = 23.1 VA**

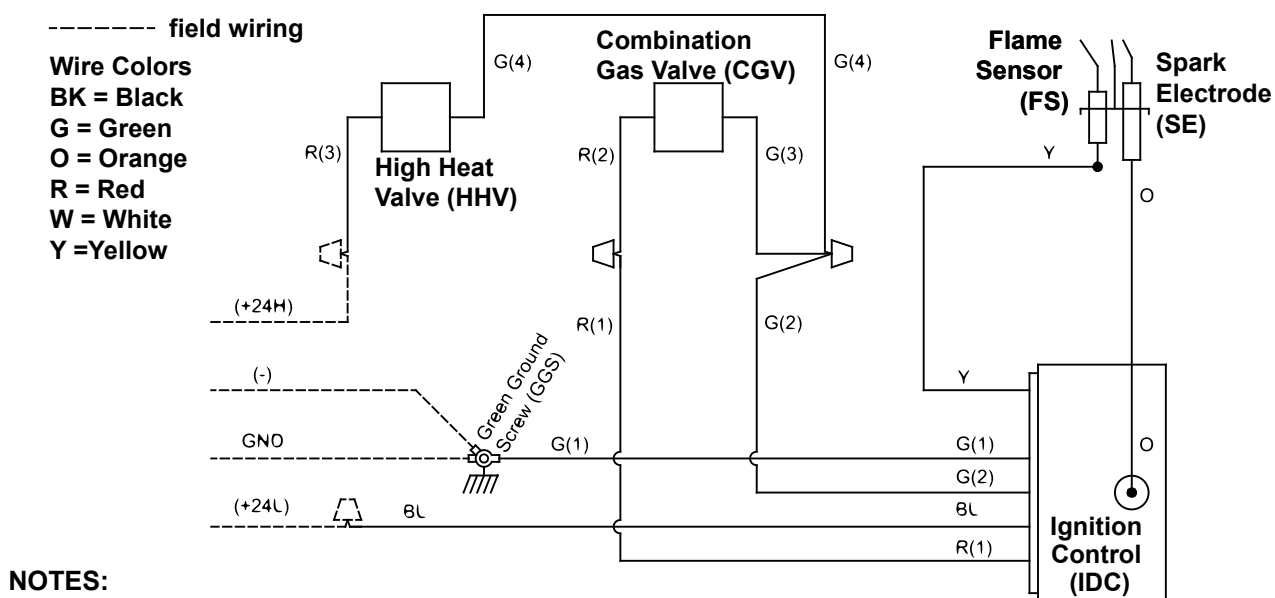

8.0 Ignition and Operation

LIGHTING INSTRUCTIONS

1. Turn manual gas valve to OFF position.
2. Turn electrical supply OFF.
3. Wait at least five (5) minutes.
4. Set thermostat above room temperature.
5. Turn manual gas valve to ON position.
6. Turn electrical supply ON.
7. Set thermostat at desired temperature.
8. If heater does not light, repeat Steps 1-7.

IMPORTANT: The control system cannot determine the presence of flame if it is not electrically grounded to the burner; the control system will lockout and shut off. The control is extremely polarity sensitive. Proper grounding and proper electrical polarity are essential to the operation of these heaters.

SEQUENCE OF OPERATION

1. Thermostat calls for heat. (2-stage models: low-heat or high-heat operation is determined by setpoints of the thermostat. Refer to thermostat manufacturer's instructions.)
2. Power is applied to the Ignition Detection Control (IDC). 15 seconds after power is applied, a spark is developed at the electrodes and the combination gas valve opens for a 15-second trial-for-ignition period.
3. Burner ignites; a small DC electrical current begins flowing from sensing electrode through flame to ground.
4. The controller senses current, turns OFF spark, gas continues to flow through the combination gas valve. (Sparking may continue for the full 15 seconds before stopping.)
5. Should the burner fail to light or flame is not detected during the first trial-for-ignition period, the combination gas valve is de-energized and the controller starts the 15-second inter-purge sequence before another ignition trial. After 15 seconds, the controller begins two (2) more ignition trials.
If the burner fails to light after the third trial, the controller will de-energize the gas valve and go into lockout mode.
6. On flame outage at the sensing electrode, the controller responds and begins sparking within 0.8 seconds. A 15-second trial-for-ignition period begins to re-light the burner. If flame is re-established, normal operation resumes. (Sparking may continue for the full 15 seconds before stopping.) Should the burner fail to light or flame is not detected during the first trial-for-ignition period, the combination gas valve is de-energized and the controller starts the 15-second inter-purge sequence before another ignition trial. After 15 seconds, the controller begins two (2) more ignition trials.
If the burner fails to light after the third trial, the controller will de-energize the gas valve and go into lockout mode.
7. For lockout recovery, reset the thermostat below the ambient temperature or disconnect electrical power supply for 5 seconds.

SHUTDOWN

- To shutdown the heater for a week or less, switch off the electrical supply to the heater.
- To shutdown the heater for more than one week, switch off the electrical supply to the heater and turn off the gas supply at the gas isolation valve.

9.0 Commissioning and Startup

- Be certain electrical supply matches voltage of unit.
- Check for proper grounding and polarity of the ignition system. The direct spark ignition system cannot determine the presence of flame if it is not electrically grounded to the burner; it will lockout and shut off.
- Clearance to combustibles must be maintained. (See Paragraph 4.2.) Check location of sprinkler heads; high temperature heads may be required. Space directly below the heater should be free of objects that may overheat or prevent infrared energy from reaching desired area. Post signs indicating maximum stacking height under or near heater.
- Heater may be angle mounted only as specified. (See Paragraph 5.0.)
- Heater must be level and suspended according to instructions in Paragraph 5.0. Be sure there are no gas or electric lines above or below the heater.
- Adequate ventilation MUST be provided. (See Paragraph 2.2.)
- Gas piping and supply must meet requirements. (See Paragraph 6.0.) Purge air from gas supply line.
- Complete the installer record on page 20 and keep these instructions for future reference.

10.0 Accessories

The following are field-installed accessories. Follow the instructions shipped with the option package.

Thermostat, Option CL34 is a 24/120 volt thermostat that can be used to control 1-5 units. This thermostat can also be used to control the exhaust fan circuit.

Thermostat, Option CL82 is a 24-volt, 2-stage digital thermostat that can be used with Option AG2R for automatic control of 1-5 units.

Parabolic Reflector, Option DM2

The addition of the parabolic reflector increases the infrared intensity pattern while decreasing the scope of heating coverage.

Installation affects clearances and mounting height; see page 7.

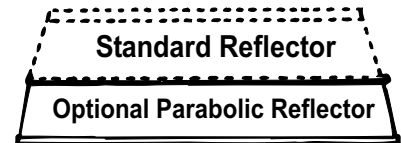

Wire Grid, Option DN2

Available on all sizes except RIHN 30.

Required on Canadian installation of Model RIHN 60.

Optional wire grid to increase radiant efficiency

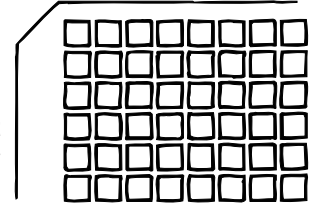

Protective Screen, Option DN3

This screen is designed to protect the ceramic block from damage caused by the entrance of foreign objects.

(NOTE: Not for use with parabolic reflector, Option DM2. If protective screen is required with parabolic reflector, contact factory.)

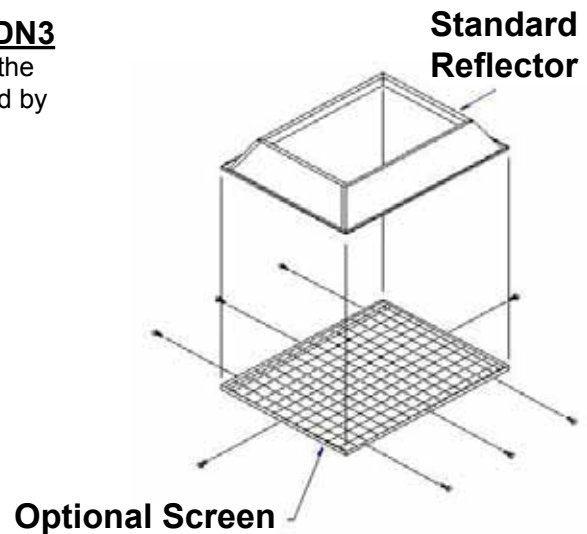

Heat Deflector, Option DO2

A heat deflector is available on Sizes 30-100 to permit less clearance above the heater. See Paragraph 4.

Chain and "S" Hooks, Option UE1

Option kit includes 50 ft (15M) of 200 lb (91 kg) chain and 14 "S" hooks.

Chain Mounting Kit, Option UE2

Option kit includes assembled chain and "S" hooks for mounting one unit (See FIGURE 4, page 8).

Gas Connector and Shutoff Valve, Option UF2

Option kit includes a 24" stainless steel gas connector and shutoff valve.

11.0 Maintenance and Service

Refer to the illustrations below.

- **FIGURE 8** illustrates general arrangement of heater operation.
- **FIGURE 9** shows the direct spark assembly.
- **FIGURE 10** illustrates burner removal.

11.1 Maintenance Procedures and Illustrations

Annual maintenance should be performed as follows:

CAUTION: Always wear protective goggles when cleaning heaters.

1. Disconnect all power sources related to the installation and close the gas supply valve at the heater.
2. With an air hose of 20 PSI (140kPa) or less, blow off all accumulated dust and dirt. Blow air over the ceramic tile (avoiding gasket material between tile) and alternately into the venturi several times in succession. Be careful not to damage gasket material between ceramic tiles. Damaging the material between the tiles could lead to burner flashback.

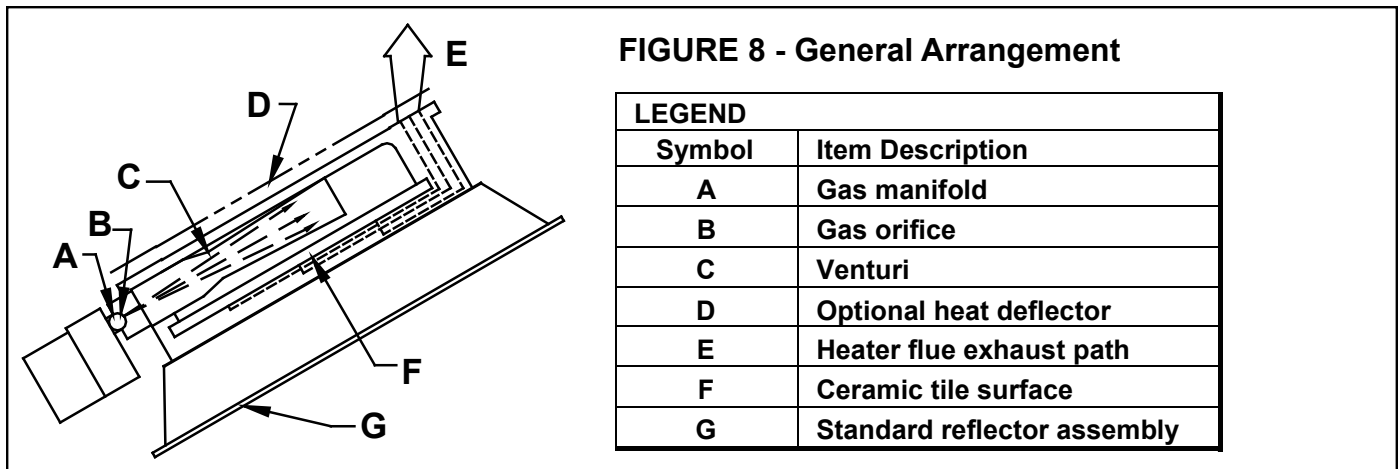

FIGURE 9 - Electrode Assembly (Direct Spark)

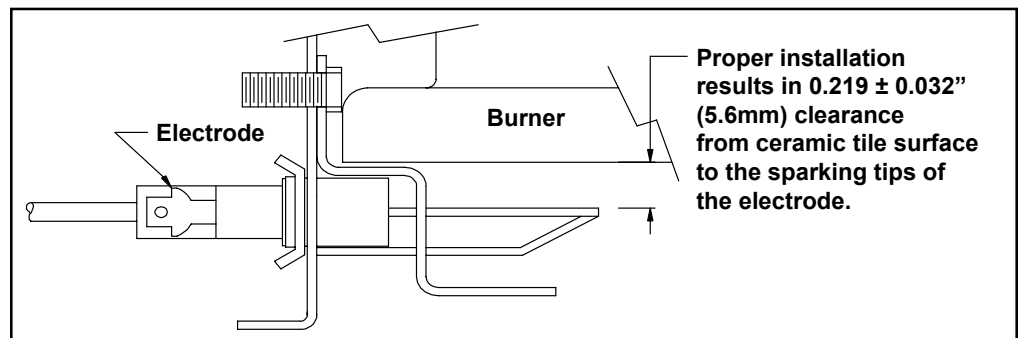
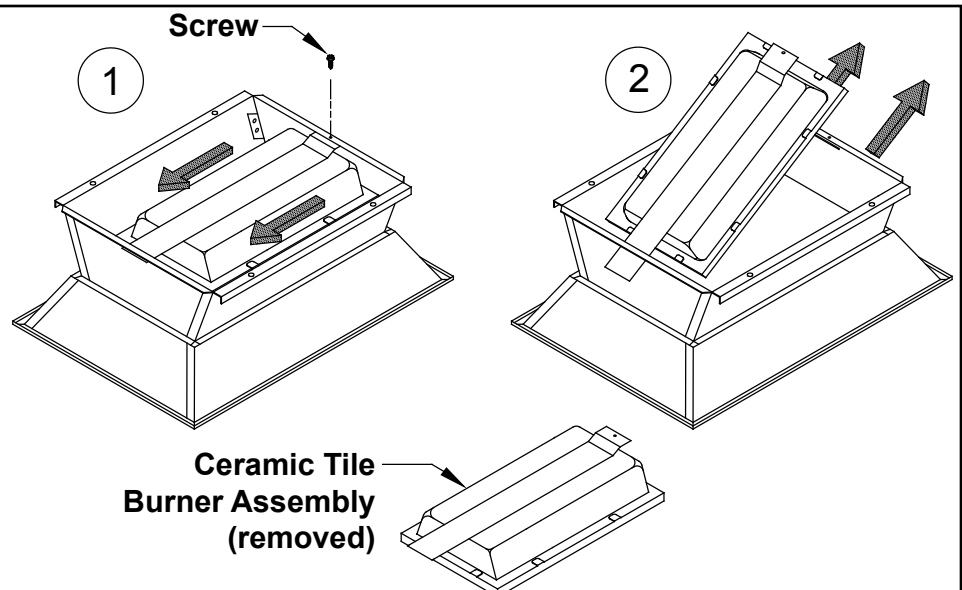

FIGURE 10 - Burner Replacement

Burner Removal Instructions

- 1) Remove screw and slide burner backward.
 - 2) Pull burner up and outward.
- Reverse the procedure to re-install burner.



11.0 Maintenance and Service (cont'd)

11.2 Troubleshooting Guide

SYMPTOM	POSSIBLE CAUSE	CORRECTIVE ACTION
Gas Odor	1. Gas pipe joints loose.	1. Check joints with non-corrosive leak detection fluid, tighten as needed.
New Installation of heaters not working	1. Heaters not isolated during high pressure leak testing of gas lines	1. Replace combination gas valve(s) on each heater.
	2. All gas lines not completely bled of air	2. Disconnect flex hose at each heater until gas is present. Connect flex hose and leak test.
	3. Gas supply regulator reversed	3. Remove and install properly.
	4. Electrical supply line voltage & neutral polarity reversed	4. Correct electrical supply polarity.
No gas	1. Gas supply valves not opened	1. Open all manual gas supply valves.
	2. Gas supply regulator sticking	2. Replace gas supply regulator.
Electrical circuit closed but heater not working. (For specific control systems see Ignition and Operation section)	1. Gas supply lacking caused control system lockout	1. Verify all gas supply valves are open. Purge air from gas supply line. Turn thermostat off – wait 5 minutes, then reset thermostat.
	2. Line fuse blown or tripped circuit breaker	2. Replace line fuse or reset breaker.
	3. Electrical power short	3. Trace and correct short.
	4. Wiring disconnected	4. Repair, see wiring diagram in Ignition section.
	5. No electrical earth ground	5. Provide electrical earth ground.
	6. Electrical supply line voltage & neutral polarity reversed	6. Correct electrical supply polarity.
	7. Exhaust fan interlock (if used) is defective	7. Replace interlock.
Direct spark fails to ignite main burner(s)	1. Combination gas valve not in the ON position	1. Turn combination gas valve to ON position.
	2. Electrode wire loose	2. Reconnect wire.
	3. Electrode wire broken or frayed	3. Replace electrode.
	4. Electrode ceramic cracked	4. Replace electrode.
	5. Electrode improperly located	5. Relocate to correct position.
	6. Gas valve fails to open when power is applied	6. Replace combination gas valve.
	7. Supply/manifold gas pressure too low	7. See rating plate on heater and adjust pressure.
	8. Ignition detection control defective	8. Replace ignition detection control.
Unit cycles on and off, erratic operation	1. Drafty condition	1. Shield heater and/or thermostat from drafts.
	2. Flame sensor wire loose or damaged	2. Replace wire harness to ignition detection control.
	3. No electrical earth ground	3. Provide electrical earth ground.
	4. Electrical supply line voltage & neutral polarity reversed	4. Correct electrical supply polarity.
	5. Heat on pilot flame sensor insufficient	5. Clean pilot, check pilot orifice and alignment.
No pilot	1. Gas line contains air	1. Purge air from gas line.
	2. Pilot line, orifice, or passage blocked	2. Check and clean. See Paragraph 11.1.
	3. Pilot solenoid valve inoperative	3. Replace combination gas valve.
Pilot goes out on 100% shut-off when hold-down button is released	1. Heat on pilot flame sensor insufficient	1. Clean pilot, check pilot orifice and alignment.
	2. Pilot flame sensor location improper	2. Correct position with respect to pilot.
	3. Manifold gas pressure low	3. See rating plate on heater and adjust pressure.
	4. Poor contact at valve end of sensing element	4. Ensure clean and proper contact.
	5. Pilot flame sensor defective	5. Replace pilot flame sensor.
	6. Pilot interrupter in combination gas valve defective	6. Replace combination gas valve
Pilot burning, no gas to main burner(s)	1. Thermostat or manual switch open	1. Raise the thermostat setting or close switch.
	2. Manual valve closed on combination gas valve	2. Turn valve to "ON" position.
	3. No power to solenoid in combination gas valve	3. Check power supply and furnish proper voltage.
	4. Heat on pilot flame sensor insufficient	4. Clean pilot, check pilot orifice, and alignment.
	5. Pilot flame sensor defective	5. Replace sensor.
	6. Combination gas valve defective	6. Replace combination gas valve.
Heater will not turn off	1. Thermostat defective	1. Replace thermostat.
Controls over-heating	1. Heater mounted incorrectly	1. See Location, Paragraph 2.0, and Suspending, Paragraph 5.
Burning of gas inside burner (flash-back)	1. Heater mounted incorrectly	1. See Location, Paragraph 2.0, and Suspending, Paragraph 5.
	2. Gas leaking from: manifold, control assembly, or pilot joints causing gas ignition at orifice	2. Check joints with non-corrosive leak detection fluid, tighten as needed.
	3. Ceramic tile(s) cracked or separating	3. Replace burner.
	4. Drafts excessive	4. Shield from drafts or relocate heater.
Carbon formation on ceramic surface or burner	1. Gas supplied is wrong type	1. Check rating plate for type of gas required.
	2. Venturi obstructed (by spider web)	2. Clean with a bottle brush.
	3. Pilot depositing carbon	3. Clean pilot and check pilot orifice.
	4. Supply/manifold gas pressure too low	4. See rating plate on heater and adjust pressure.
	5. Main gas orifice(s) misaligned	5. Consult sales agent or factory

SYMPTOM	POSSIBLE CAUSE	CORRECTIVE ACTION
Dark spots on ceramic surface	1. Foreign matter behind the ceramic surface	1. See Maintenance, Paragraph 11.1.
	2. Foreign matter inside burner assembly	2. Replace burner assembly.
Low ceramic surface temperature	1. Venturi obstructed (by spider web)	1. Clean with a bottle brush.
	2. Foreign matter in venturi	2. See Maintenance, Paragraph 11.1.
	3. Orifice partially blocked	3. See Maintenance, Paragraph 11.1.
	4. Supply gas pressure low	4. Adjust supply regulator to 7" w.c. (18cm w.c.) for natural gas, or 11" w.c. (28cm w.c.) for propane.
	5. Manifold gas pressure low	5. Adjust heater regulator to 6" w.c. (15cm w.c.) for natural gas, or 10" w.c. (25cm w.c.) for propane.
	6. Manifold misaligned from excessive torque applied on pipe at installation	6. Replace manifold.
	7. Flue gases not adequately ventilated	7. See Ventilation Requirements, Paragraph 2.2.
	8. Gas supply piping too small	8. Increase supply pressure or replace piping
2-Stage transition from low-heat to high-heat does not happen	1. Ambient temperature is still in low-heat zone of thermostat	1. Check thermostat manufacturers' instructions.
	2. Thermostat defective	2. Replace thermostat.
	3. High-heat valve not opening	3. Replace high-heat valve.
2-Stage transition from high-heat to low-heat does not happen	1. Ambient temperature has not reached low-heat zone of thermostat	1. Allow time for ambient temperature to reach low-heat zone of thermostat. Check thermostat manufacturer's instructions.
	2. Thermostat defective	2. Replace thermostat.
	3. High-heat valve not closing	3. Replace high-heat valve.

Index

A

Accessories 16
Mounting Angle 7

B

Burner Replacement 17

C

Chain 16
Chain Hanging Arrangement 8
Chain Mounting Kit 16
Clearances 6
Commissioning and Startup 15

D

Dimensions 6

E

Electrical Connection Diagram 12
ELECTRICAL CONNECTION DIAGRAM 13
Electrical Supply 10
Electrode Assembly (Direct Spark) 17

G

Gas Connector 16
Gas Pressure 10
Gas Supply Connections 9
Gas Supply Line 9
General 2
General Arrangement 17

H

HAZARD INTENSITY LEVELS 2
Heat Deflector 16
High Altitude 3

I

Ignition and Operation 14
Installation Codes 3

L

LIGHTING INSTRUCTIONS 14
Location 4

M

Maintenance 17
Mounting Heights 4

P

Parabolic Reflector 16

R

Receiving 5

S

Screen 16
SEQUENCE OF OPERATION 14
Service 17
SHUTDOWN 14
Suspending 7

T

Thermostat 16
Troubleshooting Guide 18

V

Ventilation Requirements 5

W

Warranty 3
Weight 7
Wire Grid 16
Wiring Diagrams 12

INSTALLATION RECORD - to be completed by the installer:

Installer:

Name _____
Company _____
Address _____

Phone _____

Distributor (company from which the unit was purchased):

Contact _____
Company _____
Address _____

Phone _____

Model No. _____ Serial No. _____ Date of Installation _____

SPECIFIC INSTALLATION NOTES: (i.e. Location, Clearances, Amps, Gas Pressure, Temperature, Voltage, Warranty, etc.)

BUILDING OWNER OR MAINTENANCE PERSONNEL:

For service or repair:

- Contact the installer listed above.
- If you need additional assistance, contact the Distributor listed above.
- For more information, contact:

North America Web: www.RezSpec.com; Call: 800-695-1901

Asia Web: www.Reznor.cn

Europe Web: www.Reznor.eu

Australia Web: www.ReznorOnLine.com

Reznor/Thomas & Betts
150 McKinley Avenue
Mercer, PA 16137
United States

Gaz Industrie/Thomas & Betts
ZI de Rosarge - 230 Rue de la Dombes
Les Echets - 01706 Miribel cedex
France
gazindustrie@gazindustrie.fr