

Parts List for SW45PRE

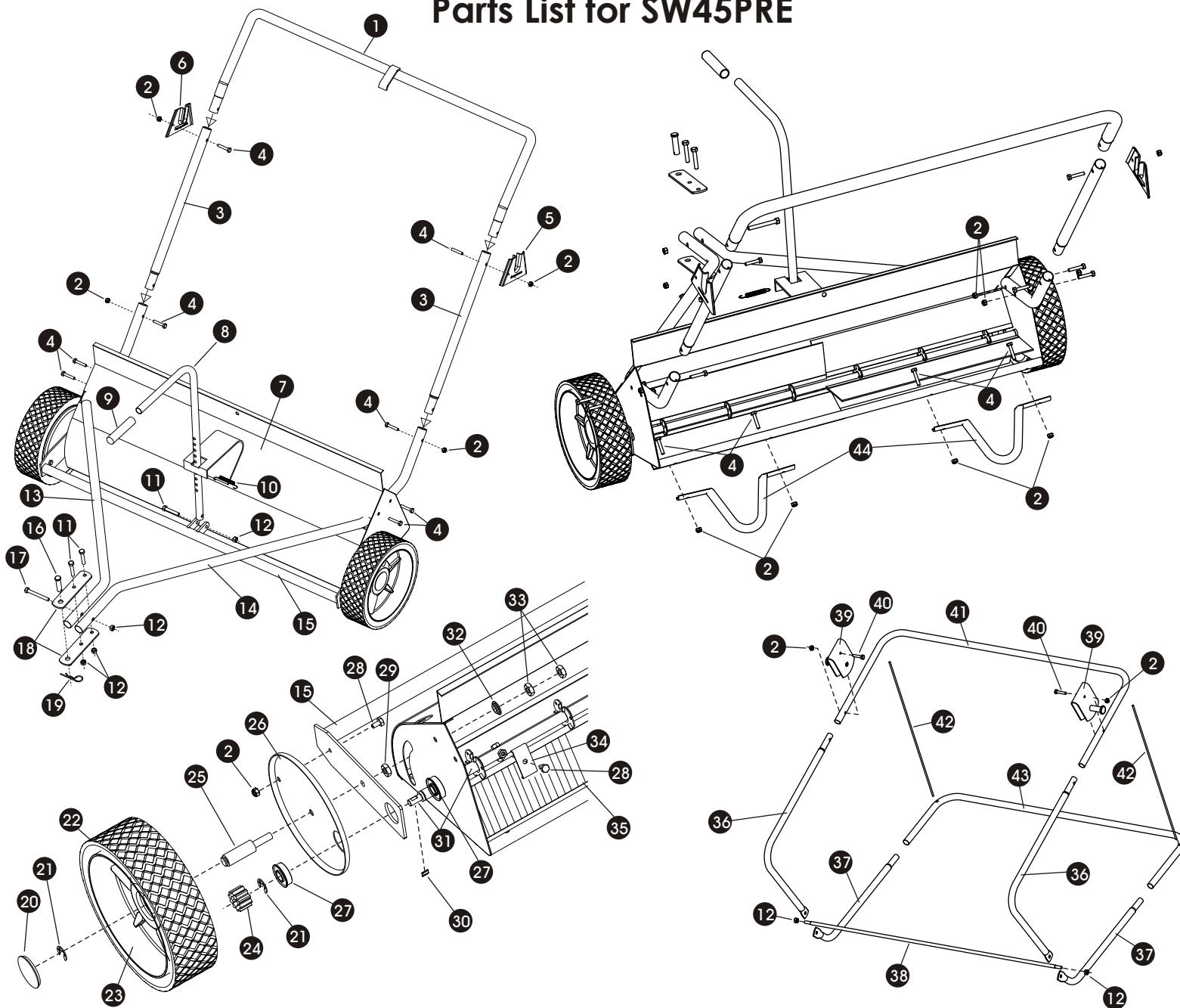

Precision

SW45PRE - 45" Tow Behind Lawn Sweeper

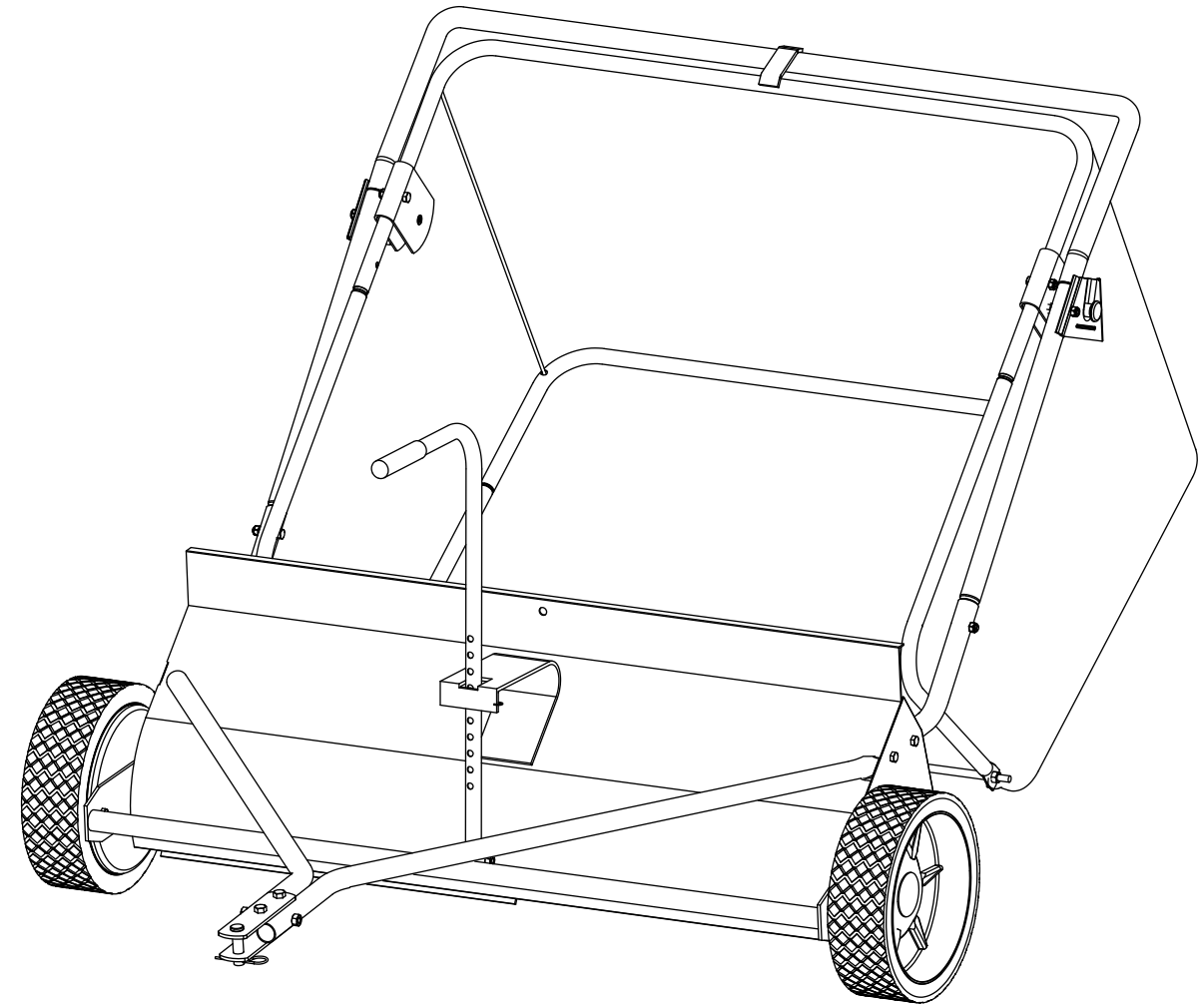

Ref #	Part #	Part Description	Qty.	Ref #	Part #	Part Description	Qty.
1	1735	Top Frame Tube	1	25	1708	Stub Axle	2
2	1778	1/4" Nylon Lock Nut	16	26	1709	Wheel Shield	2
3	1701	Side Frame Tube	2	27	1770	Flange Bearing	4
4	6129	1/4" x 1-3/8" Hex Head Bolt	12	28	1647	1/4" x 1/2" Hex Head Bolt	14
5	1776	LH Hamper Pivot Bracket	1	29	1771	3/8" Lock Nut	2
6	1774	RH Hamper Pivot Bracket	1	30	1772	Pinion Pawl	2
7	1703	Sweeper Chassis	1	31	1738	Brush Axle / Disc Assembly	1
8	1745	Height Adjustment Tube	1	32	1710	Pilot Spacer	2
9	1746	Handle Grip	1	33	1273	3/8" Hex Head Nut	4
10	1282	Spring	1	34	1739	Brush Clamp	12
11	2051	5/16" x 1-3/4" Hex Head Bolt	3	35	1785	Brush Strip	6
12	1749	5/16" Nylon Lock Nut	6	36	1711	Top Hamper Side Tube	2
13	1704	RH Hitch Arm Tube	1	37	1712	Bottom Hamper Side Tube	2
14	1705	LH Hitch Arm Tube	1	38	1760	Hamper Tie Rod	1
15	1706	Bumper Assembly	1	39	1755	Hamper Pivot Bracket Assembly	2
16	1840	Clevis Pin	1	40	1660	1/4" x 1-1/4" Hex Head Bolt	2
17	1707	5/16" x 2-3/4" Hex Head Bolt	1	41	1713	Top Hamper Cross Tube	1
18	1753	Clevis Plate	2	42	1714	Fiberglass Hamper Support Rod	2
19	1042	Hitch Pin Clip	1	43	1732	Bottom Hamper Cross Tube	1
20	1769	Plastic Hub Cap	2	44	1734	Leg Stand	2
21	1768	5/8" E Type Snap Ring	4			**PARTS NOT ILLUSTRATED	
22	1766	10" Tire	2	**	1788	Hamper (Material)	1
23	1767	10" Die Cast Wheel	2	**	1789	Wind Apron	1
24	1765	Pinion Gear	2	**	1790	Hamper Dump Rope	1

Owner's Manual and Parts List

Precision Products, Inc.

11/05

Customer Service & Warranty Information

Parts list on back page

PLEASE DO NOT RETURN THIS MERCHANDISE TO THE STORE. CALL US AND WE WILL TAKE CARE OF ANY PROBLEM YOU MIGHT HAVE WITH THIS PRODUCT. Phone (800) 225 - 5891 EXT. #204

LIMITED WARRANTY

When ordering parts always give model number, part description & part number.

This unit is warranted against defects in materials and workmanship to the original purchaser, under normal use and service, for a period of ninety (90) days from date of sale. During the Warranty Period, we will repair or replace at our option free of charge to the original purchaser, any part of the Unit that our examination shows to be defective in workmanship or materials. This Warranty **Does Not** apply to damage caused by misuse, abuse, neglect, accident, normal wear, or alterations by unauthorized persons.

Send To: Precision Products, Inc.
Parts Division
316 Limit Street
Lincoln, IL 62656

Phone (217) 735-1590
Fax (217) 735-2435

Your new SW45PRE lawn sweeper is precision manufactured using the finest in tools and materials. Although it is ruggedly constructed, do not subject this unit to misuse. Be sure to wipe off your unit after each use. Store in a dry place out of direct sunlight. Do not permit the lawn sweeper to stand in the hot sun, unless it is in actual use.

You will find many work saving uses for your lawn sweeper. Use it early in the spring to give your lawn a good healthy scrubbing. Use it throughout spring and summer before and after mowing. Sweeping your lawn before mowing stands the grass up for a clean, even cut. It also allows increased protection to your mower by removing sticks, stones and nuts, which might damage the blade(s) on your mower. Sweeping your lawn after mowing will whisk away unsightly grass clippings - leaving your lawn velvety smooth.

Tools Required For Assembly

- One (1) - Pair Pliers (Needle Nose)
- Two (2) - 7/16" Wrenches
- Two (2) - 1/2" Wrenches

Prior To Assembly:

Remove all Sweeper Parts from carton. Make sure all parts and assemblies are present before assembly. If any parts are missing, contact Customer Service (contact information on back sheet) immediately for assistance. Lay out all parts and have tools ready.

Parts List Of SW45PRE

Assembly Parts List Description

Ref.	Description	Qty.	Ref.	Description	Qty.
A	Hamper Assembly	1	I	Top Hamper Side Tubes	2
B	Chassis Assembly	1	J	Bottom Hamper Side Tubes	2
C	Hamper Pivot Brackets	2	K	Height Adjustment Tube	1
D	Clevis Plates	2	L	RH Hitch Arm Tube	1
E	Bottom Hamper Cross Tube	1	M	Leg Stands	2
F	Top Frame Tube	1	N	Side Frame Tubes	2
G	Wind Apron	1	O	LH Hitch Arm Tube	1
H	Fiberglass Hamper Support Rods	2	P	Hardware Sack	1

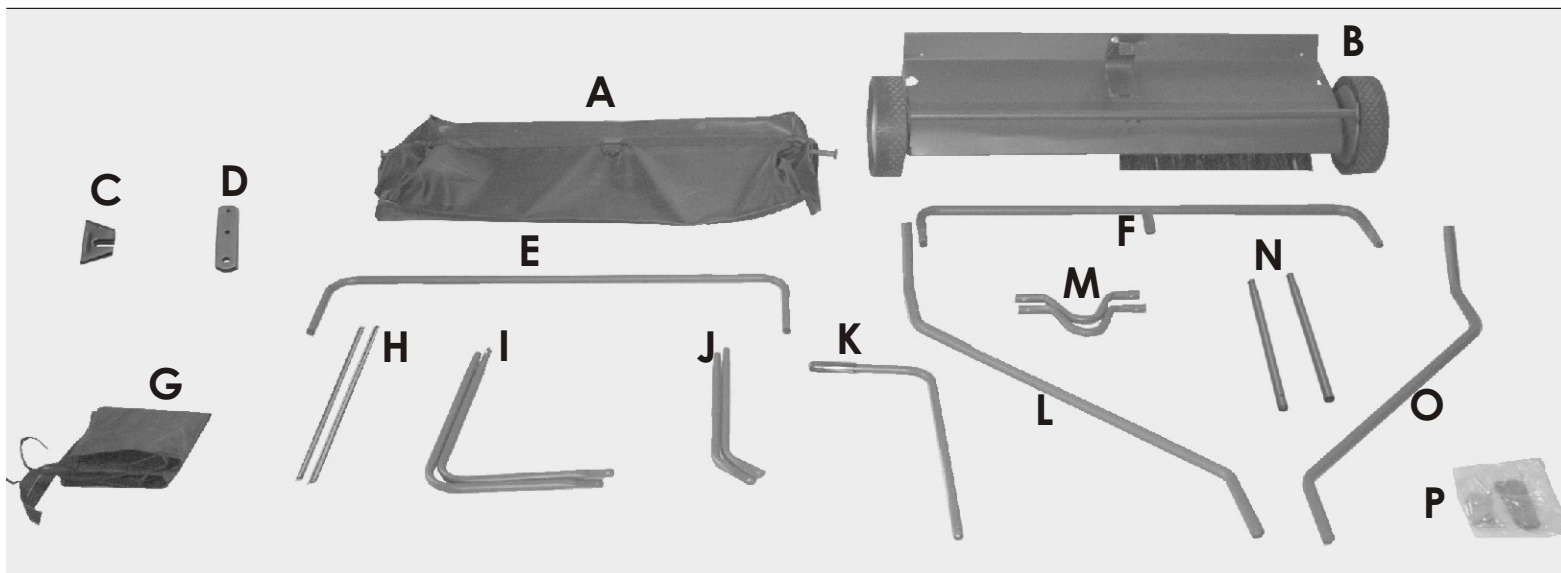

OPERATION:

Brush Adjustment: To raise the brushes further away from the ground, push the Height Adjustment Tube back and down until desired sweeping height is attained. To lower, push the Height Adjustment Tube back and pull up to desired sweeping height (See Fig 7). For best results, brushes should barely touch the top of the grass blades. Brushes should be raised when transporting the unit to and from sweeping area.

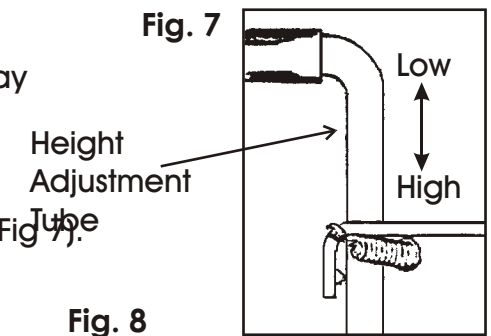

Sweeping Speed: For best results, rider/tractor should travel at a 3 to 5 M.P.H. range.

Dumping: Simply pull the Hamper Dump Rope forward to empty debris (See Fig. 8). Slowly ease the Hamper Dump Rope back, keeping even pressure, until the Hamper returns back down.

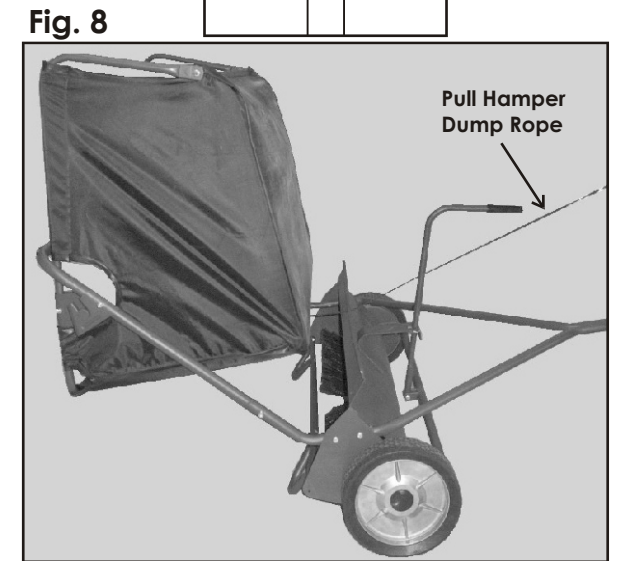

CAUTION: DO NOT ALLOW THE HAMPER DUMP ROPE TO HAVE TOO MUCH SLACK IN IT WHEN OPERATING. THE ROPE CAN GET CAUGHT IN THE BRUSHES CAUSING INJURIES.

MAINTENANCE:

Lubrication: Remove wheel by removing plastic hubcap and snap ring. Apply a light multipurpose grease to wheel gear and pinion gear. NOTE: DO NOT allow grease to enter center of pinion gear. Lubricate at the beginning of each season or more often as conditions dictate. See Fig. 9. Remove pinion gear and oil pawl with SAE #20 or equivalent. Do not apply grease or heavy oil to pawl. This causes the pawl to stick and operate erratically. When installing pinion and pawl, refer to Fig 10 for correct position. Apply SAE #20 oil or equivalent to brush axle bearings twice a season. Oil Hamper pivot pins occasionally to prevent rust and insure easy dumping.

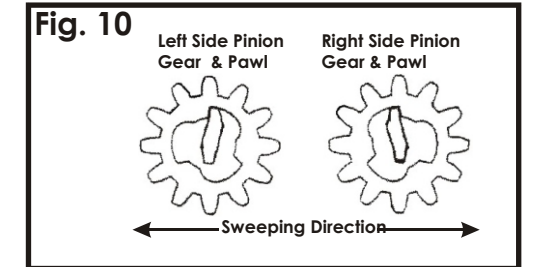
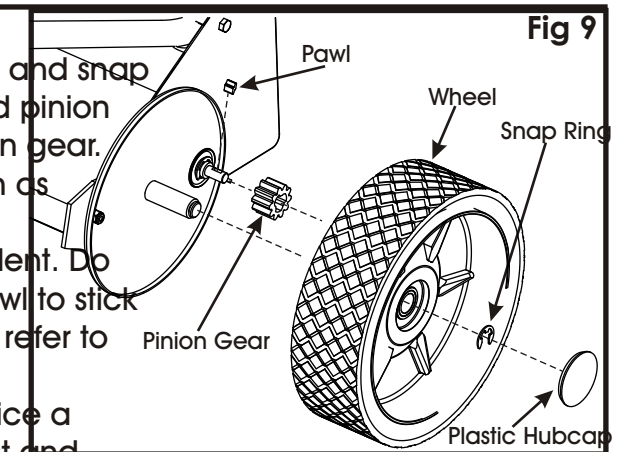

Brush Replacement:

Remove the Hex Head Bolts holding on the Brush Clamps. Place Brush Strips in slots of brush disc so shorter supporting bristles are away from brush sweeping rotation. Place the Brush Clamp against the Brushes and tightly secure with the Hex Head Bolts into the nut on the Brush Axle. See Fig. 11

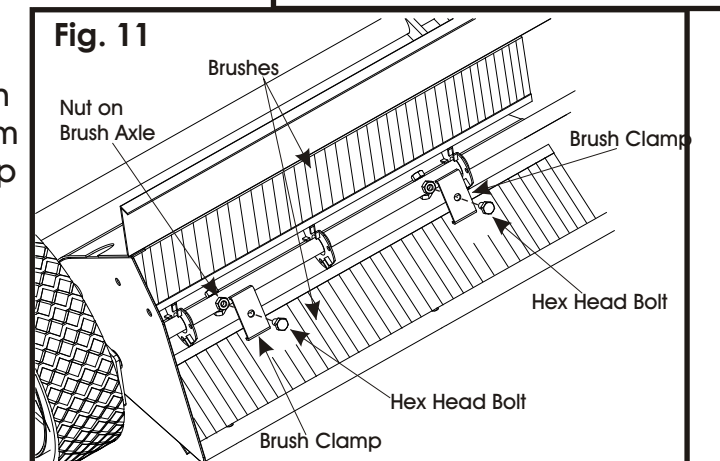

Step 7

Insert the Hamper Dump Rope through center hole on the Sweeper Chassis Assembly. Next, lay the Hamper Dump Rope behind the sweeper. Fig. 4

Install the Hamper Assembly onto the frame assembly. The Hamper Pivot Bracket Assemblies fit inside the slots on both Pivot Brackets on the frame of the sweeper. Fig. 5

The Hamper Dump Rope needs to go under and up the back side of the Hamper Assembly for proper dumping operation. Tie the Hamper Dump Rope end to the center of the Top Hamper Cross Brace. Fig. 6

Fig. 4

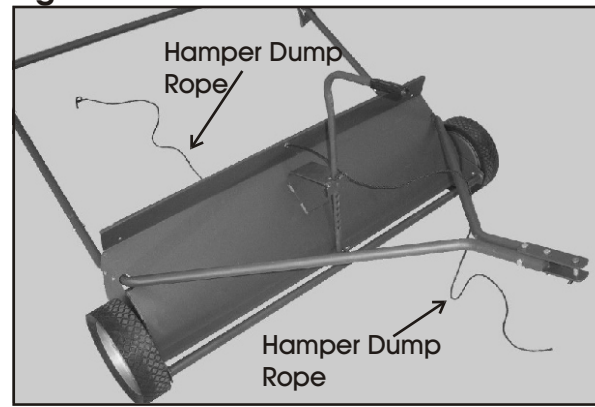

Fig. 5

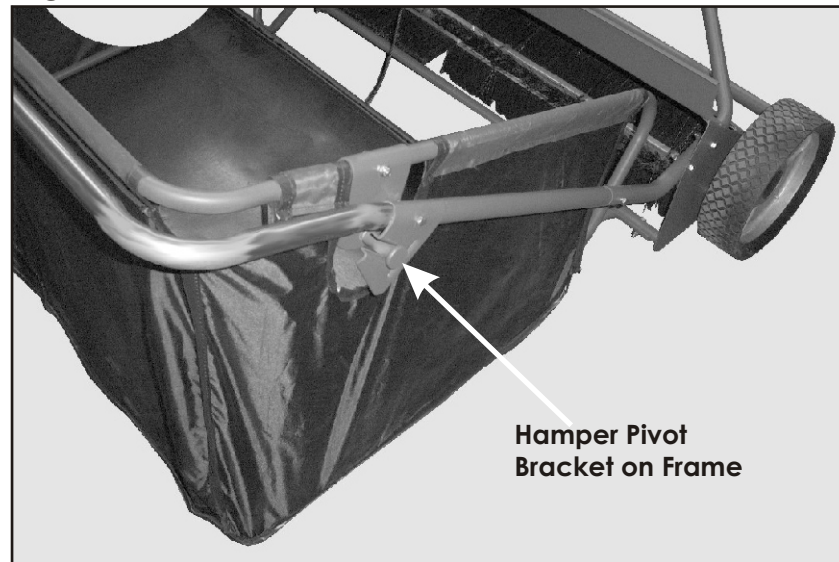
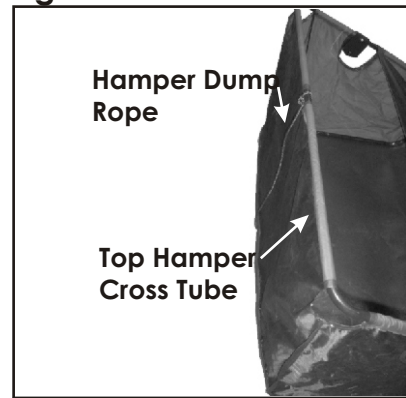

Fig. 6



STORAGE:

For long term storage, you can remove the Tube Frame Assembly (both RH and LH Side Frame and Top Frame Tube) and the Fiberglass Hamper Support Rods on the Hamper Assembly to reduce total storage area.



NOTE: ALL REFERENCES TO "RIGHT" (RH), AND "LEFT" (LH) DIRECTIONS ARE IN REFERENCE TO POSITION BEHIND SWEEPER.

Step 1

Attach the Leg Stands (M) to the Chassis Assembly (B) rear tube using four 1/4" x 1-3/8" Hex Head Bolts and securing with four 1/4" Nylon Lock Nuts.

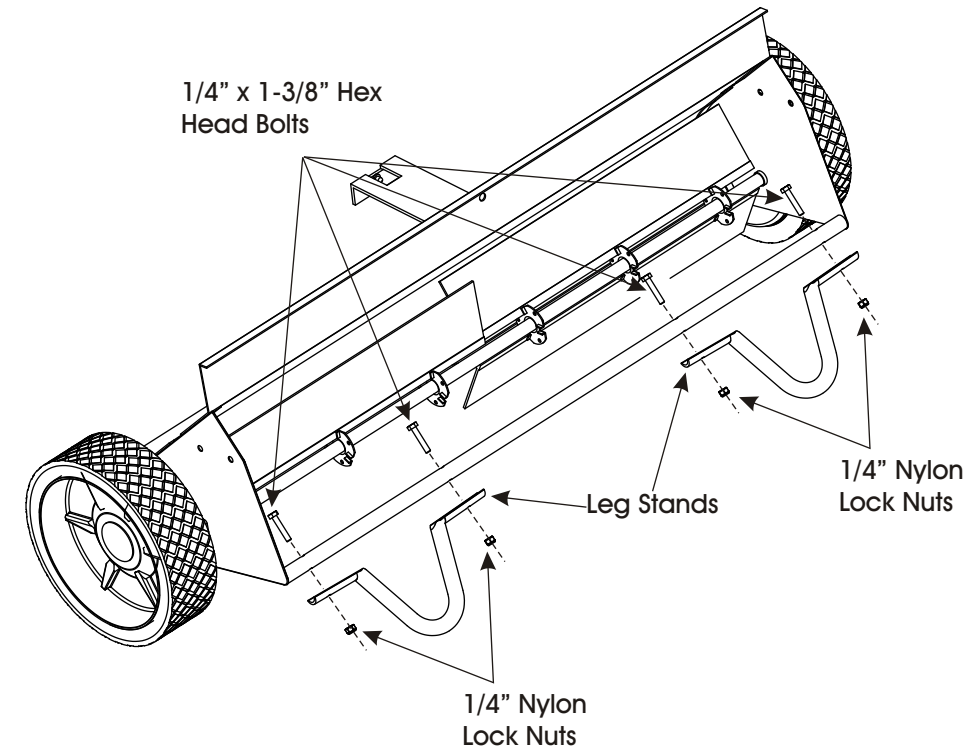

Step 2

Attach the Height Adjustment Tube (K) to the chassis Bumper Assembly using a 5/16" x 1-3/4" Hex Head Bolt and a 5/16" Nylon Lock Nut. Connect one end of the Spring to one side of the bracket then stretch around the Height Adjustment Tube and connect the other end of the spring to the opposite side of the bracket.

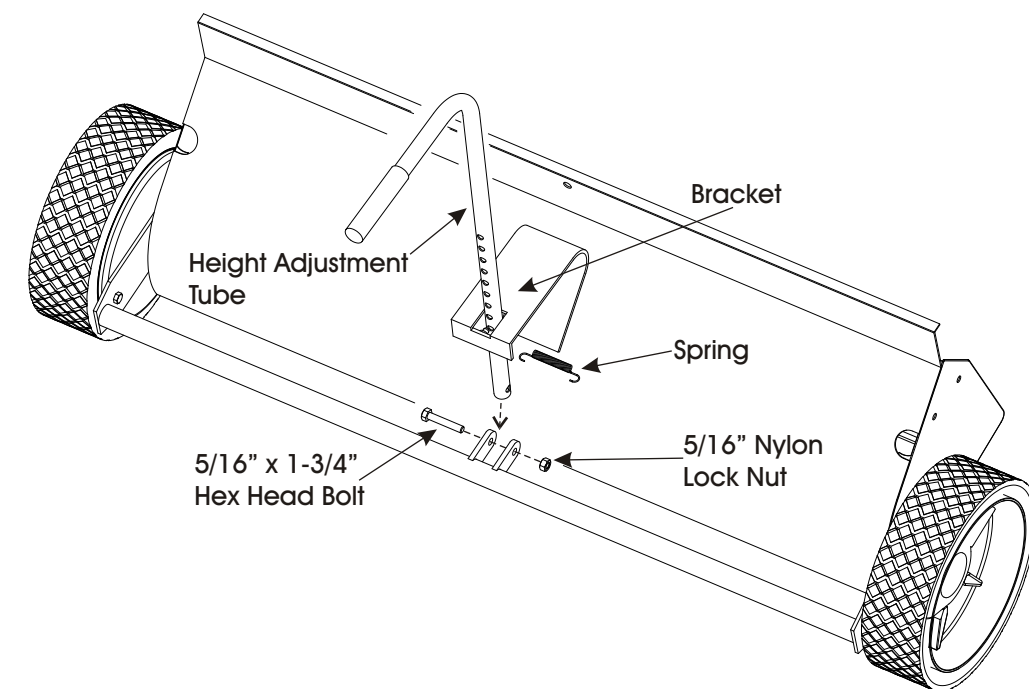

Step 3

Insert both the RH Hitch Arm Tube (L) and the LH Hitch Arm Tube (O) through the holes in the Chassis Assembly as shown. Attach both Hitch Arm Tubes to the Chassis Assembly using four 1/4" x 1-3/8" Hex Head Bolts and four 1/4" Nylon Lock Nuts. **DO NOT TIGHTEN THESE BOLTS COMPLETELY YET!** Next, insert the 5/16" x 2-3/4" Hex Head Bolt through the end of both Hitch Arm Tubes and thread a 5/16" Nylon Lock Nut onto it. **DO NOT TIGHTEN THIS BOLT YET EITHER.** Attach the Clevis Plates to the Hitch Arm Tubes using two 5/16" x 1-3/4" Hex Head Bolts and two 5/16" Nylon Lock Nuts. **DO NOT TIGHTEN THESE BOLTS YET.** First tighten the 5/16" x 2-3/4" Hex Head Bolt and Lock Nut. Next, Tighten the two 5/16" x 1-3/4" Hex Head Bolts and Lock Nuts. Finally, Tighten the 1/4" x 1-3/8" Hex Head Bolts and Lock Nuts connecting the Hitch Arm Tubes to the Chassis Assembly. Insert the Clevis Pin in through the holes on the end of the Clevis Plates and secure with the Hitch Pin Clip.

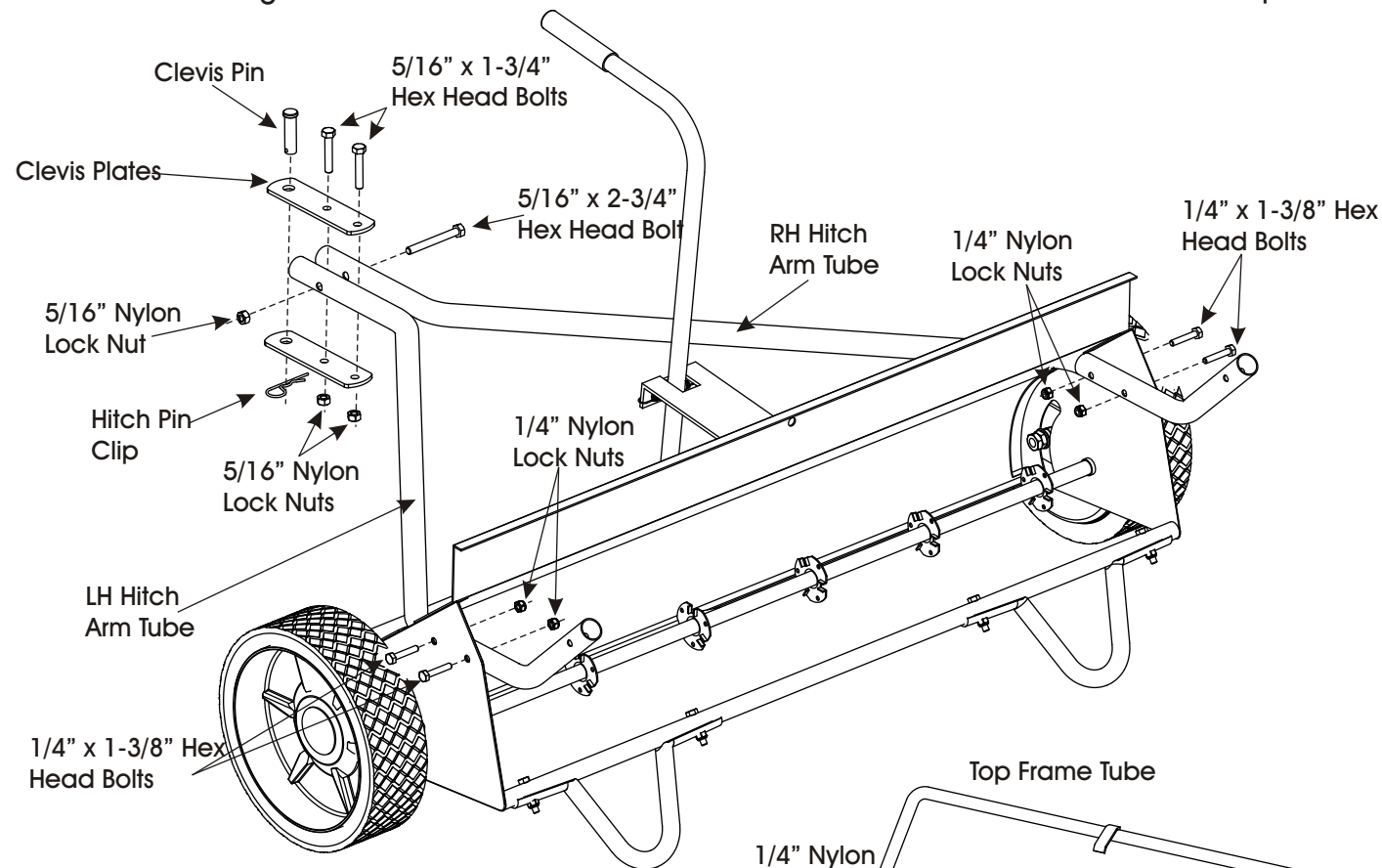

Step 4

Attach both Side Frame Tubes (N) to the ends of the Hitch Arm Tubes using two 1/4" x 1-3/8" Hex Head Bolts and two 1/4" Nylon Lock Nuts. Be sure to attach the bolts from inside to out. This eliminates any chances of the hamper bag snagging and ripping during use. Next, insert the Top Frame Tube (F) inside both upper ends of the Side Frame Tubes. Attach both Hamper Pivot Brackets (C) (on the outside of the tubes) using 1/4" x 1-3/8" Hex Head Bolts and 1/4" Nylon Lock Nuts.

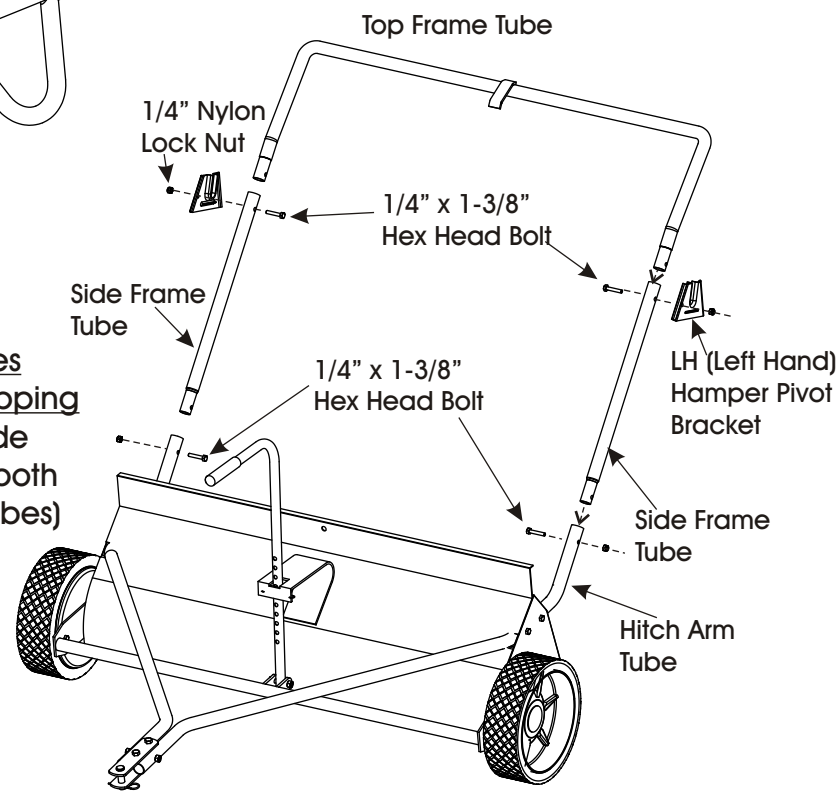

Step 5

Insert both Top Hamper Side Tubes (I) through the loop on the fabric of the hamper (Outlined). Secure to the Top Hamper Cross Tube using the spring button located on the ends. Fig. 1

Place the Bottom Hamper Cross Tube (E) into the hamper basket assembly with the holes facing up. Next, insert the Bottom Hamper Side Tubes (J) on each end of the Bottom Hamper Cross Tube. Fig. 2

Attach first, the Bottom Hamper Side Tube to the Hamper Tie Rod (inside the fabric of the hamper) followed by the Top Hamper Side Tube. Secure each side of the Hamper Tie Rod with two 5/16" Nylon Lock Nuts. Fig. 3

Fig. 1 Top Hamper Cross Tube

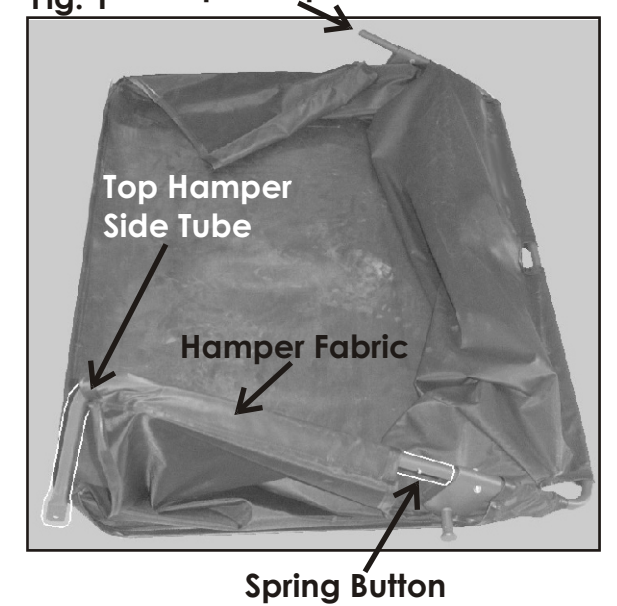

Fig. 2

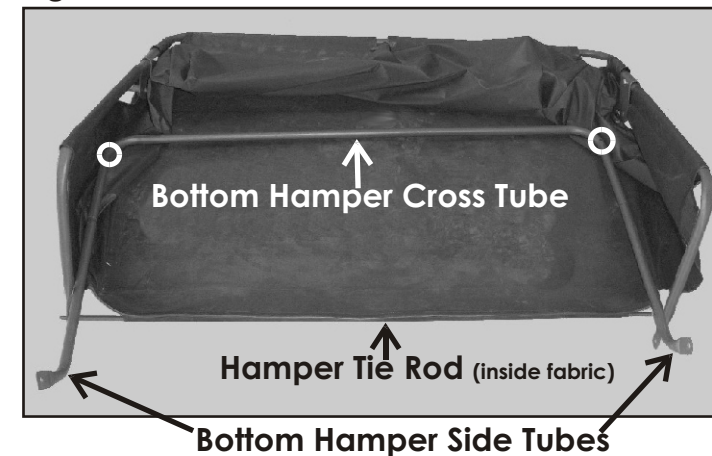
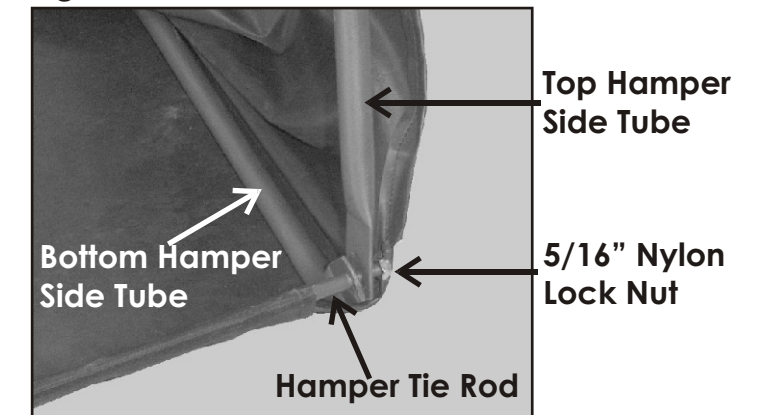

Fig. 3



Step 6

Insert one end of the Fiberglass Hamper Support Rod (H) into the hole on the Top Hamper Cross Tube (you may have to move the fabric together to find). Bend the Fiberglass Hamper Support Rod and pull up on the Top Hamper Cross Tube to insert the other end of the rod into the hole located on the Bottom Hamper Cross Tube. Repeat this for the other side.

Fiberglass Hamper Support Rod

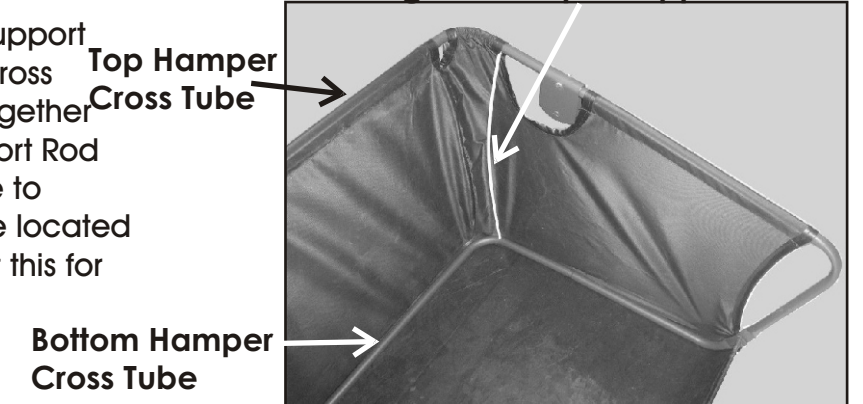

Attach the optional Wind Apron to the outside tubes towards the front of the Hamper Assembly. The Wind Apron helps keep debris from blowing out of the Hamper Assembly while the unit is in use.

