

Tire tread pattern may vary.

Manual Contents

Safety Instructions	2
Assembly.....	4-6
Operation.....	6
Maintenance.....	6
Parts.....	3&7
Warranty.....	8

Your New Trailer Dump Cart

Congratulations on your purchase of a new Precision Products, Inc. Trailer Dump Cart. Your Trailer Dump Cart has been engineered and built to give you the most dependable and best performing product possible.

If you experience any problem you can not easily resolve, please feel free to contact our knowledgeable and helpful customer service department toll-free at **1 (800) 225-5891**.

Caution: Carefully read all rules and instructions for safe operation.



Rules for Safe Operation

The following safety precautions are suggested. This Trailer Dump Cart is designed, engineered and tested to offer reasonably safe and effective service, provided that it is operated in strict accordance with these instructions. Failure to do so may result in personal injury. Always observe the rules of safe operation. Please read and retain this manual.

- Read and understand your tractor's owners manual and towing safety rules. Know how to operate your tractor before using any attachment.
- Do not allow anyone to ride or sit on tow behind equipment during operation.
- Be alert for holes in the terrain and other hazards. This could cause you to lose control of the cart and lawn tractor.
- Follow maintenance and lubrication instructions as outlined in this manual.
- Tractor braking and stability may be affected with the attachment of this unit. Be aware of changing conditions on slopes. Refer to safety rules in your tractor owner's manual concerning safe operation on slopes. **Stay Off Steep Slopes.**
- Always operate up and down a slope, never across the face of a slope.
- Do not drive close to creeks, ditches or public highways.
- Always wear substantial footwear. Do not wear loose fitting clothing that may get caught in moving parts.
- Avoid extremely sharp turns.
- Follow the maintenance instructions as outlined in this owner's manual.
- Do not exceed maximum towing speed of 3-4 M.P.H.
- Maximum Carrying Capacity 1500 Lbs. Consult tractor owners manual.
- **Warning of danger of improper use of the Trailer Dump Cart.** This unit is intended for use only with Riding Mowers or Garden Tractors. It is definitely not for Highway use, being pulled at high speeds, or transporting passenger(s) of any sort. Such use could result in injuries for which we cannot be held responsible.

Carton Contents

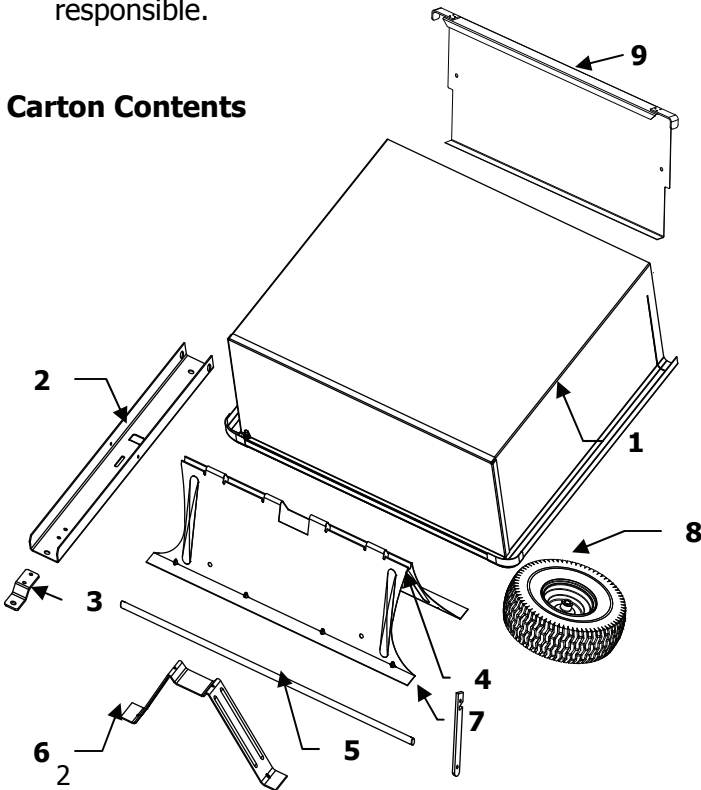

Ref.	Qty.	Description
1	1	Body
2	1	Tow Bar
3	1	Clevis Plate
4	1	Undercarriage Axle Support
5	1	Axle
6	1	Pedestal
7	1	Latch
8	2	Wheels
9	1	Tailgate

Shown Full Size

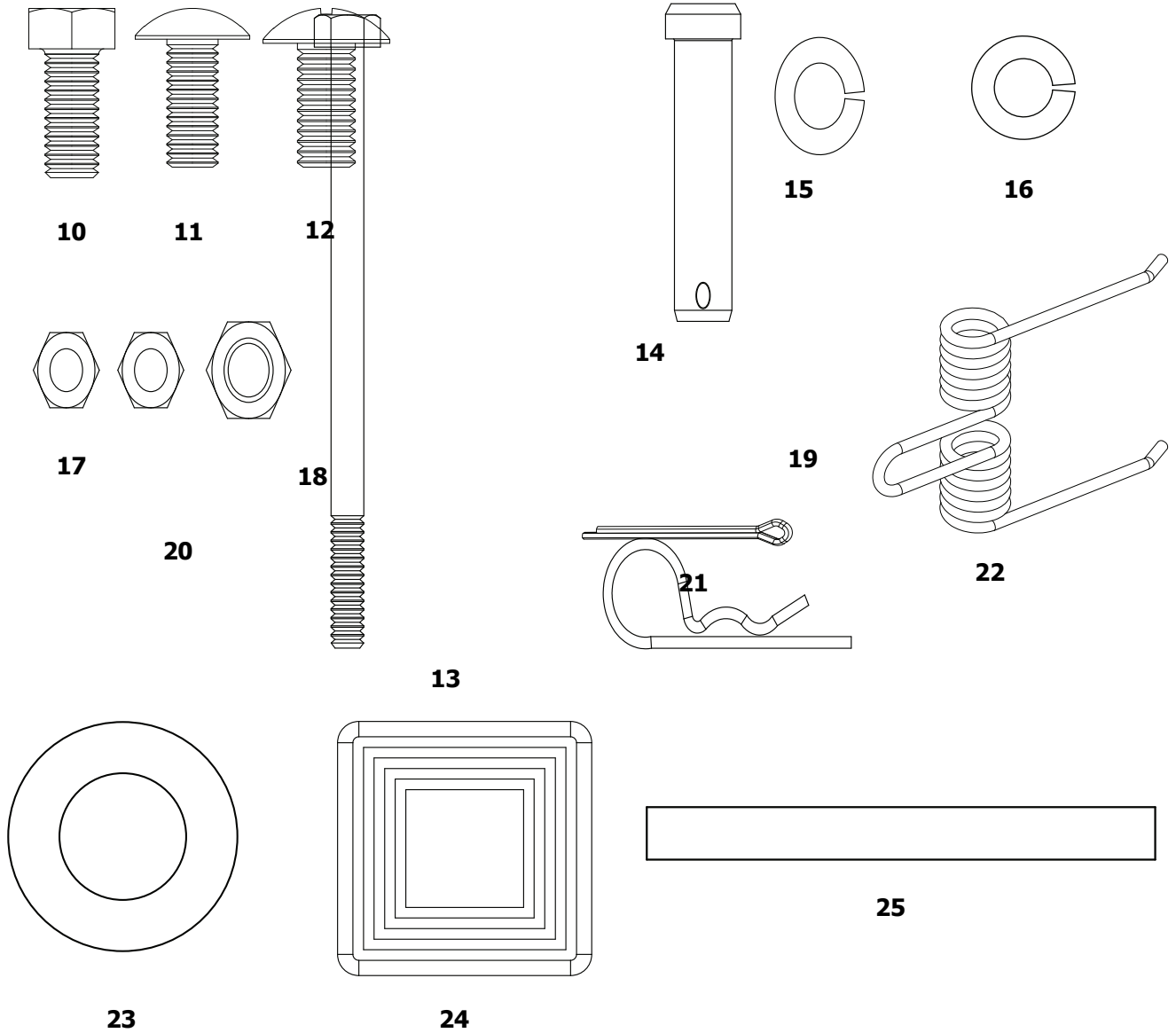

Ref.	Qty.	Description
10	2	5/16" x 3/4" Hex Head Bolt
11	4	5/16" x 3/4" Truss Head Bolt
12	12	3/8 x 3/4" Truss Head Bolt
13	1	1/4" x 3-1/2" Hex Head Bolt
14	1	1/2" x 1-3/4" Clevis Pin
15	12	3/8" Lock Washer
16	6	5/16" Lock Washer
17	1	1/4" Reverse Lock Nut
18	6	5/16" Hex Head Nut
19	12	3/8" Lock Washer
20	1	#14 Hitch Pin Clip
21	2	1/8" x 1-1/4" Cotter Pin
22	1	Spring
23	6	3/4" Flat Washer
24	2	1-1/2" x 1-1/2" Tube Plug
25	1	1/4" x 3" Spacer Tow Bar

Assembly Instructions

Tools Needed For Cart Assembly

- (2) 7/16" Wrenches
- (2) 1/2" Wrenches
- (1) 9/16" Wrench
- (1) Pair Pliers
- (1) Large Standard or Flat Screwdriver

Remove from Carton

Remove all parts and hardware packages from the carton. Lay out all parts and hardware and identify them using the illustrations on pages 2 and 3.

1. Slide Spring over the Latch Handle as shown in Figure 1.

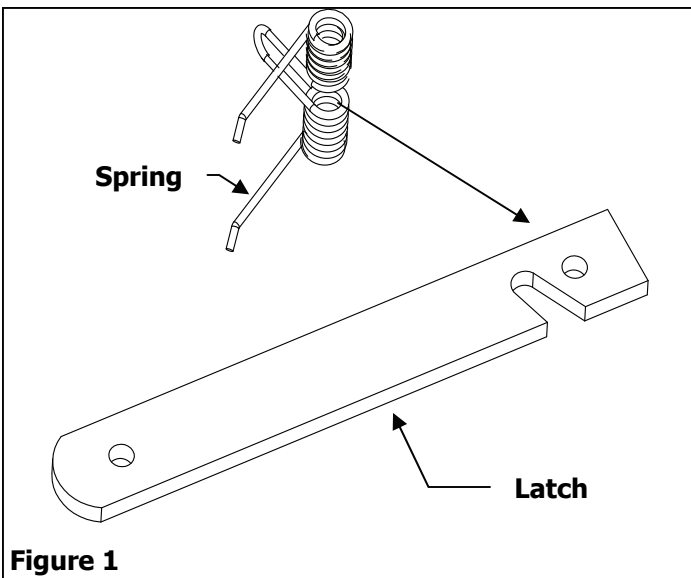

2. Slide the 1/4" x 3" Spacer through the Spring and Latch as shown in Figure 2.

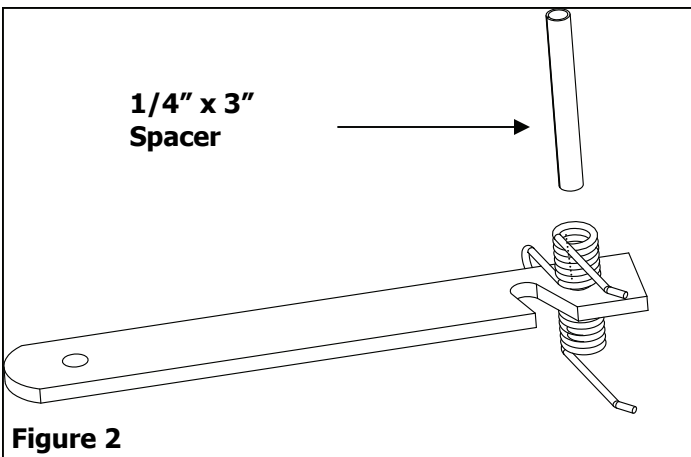

3. Slide the Latch, Spring and Spacer through the Tow Bar. This will cause the Spring to open. See Figure 3.

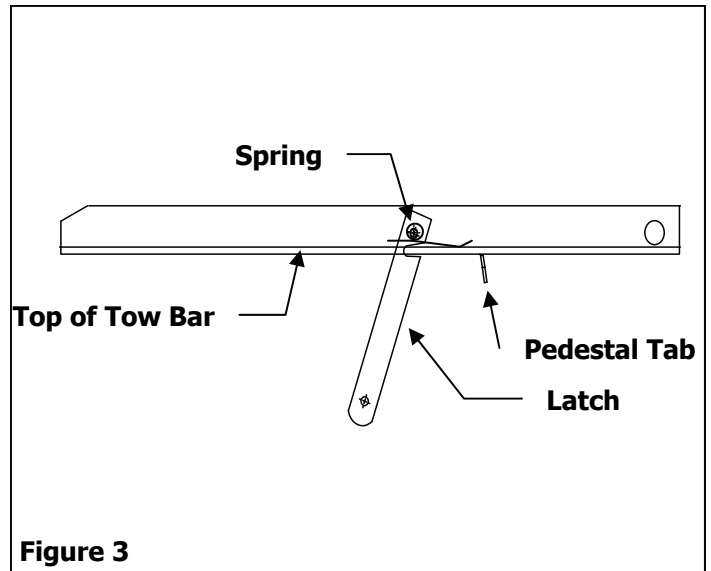

4. Slide 1/4" x 3-1/2" Hex Head Bolt through Spacer and secure with a 1/4" Nylock Nut. See Figure 4.

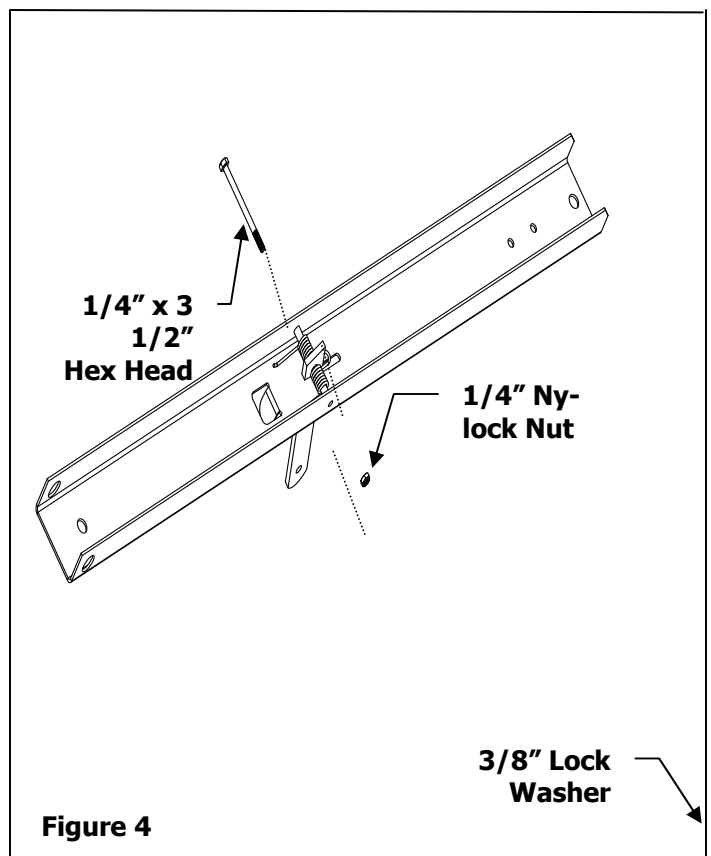

3/8" Hex Head Nut

5. If assembled correctly the Latch should be forced toward the back of the Tow Bar by the spring. See Figure 5.

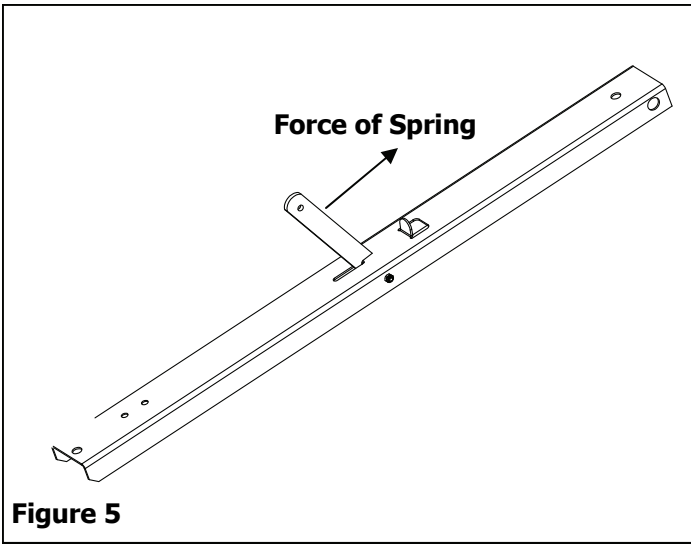

6. Attach Undercarriage Axle Support to the bottom of the Body. Use 3/8" x 3/4" Truss Head Bolts, 3/8" Lock Washers, and secure with 3/8" Hex Head Nuts. See Figure 6.

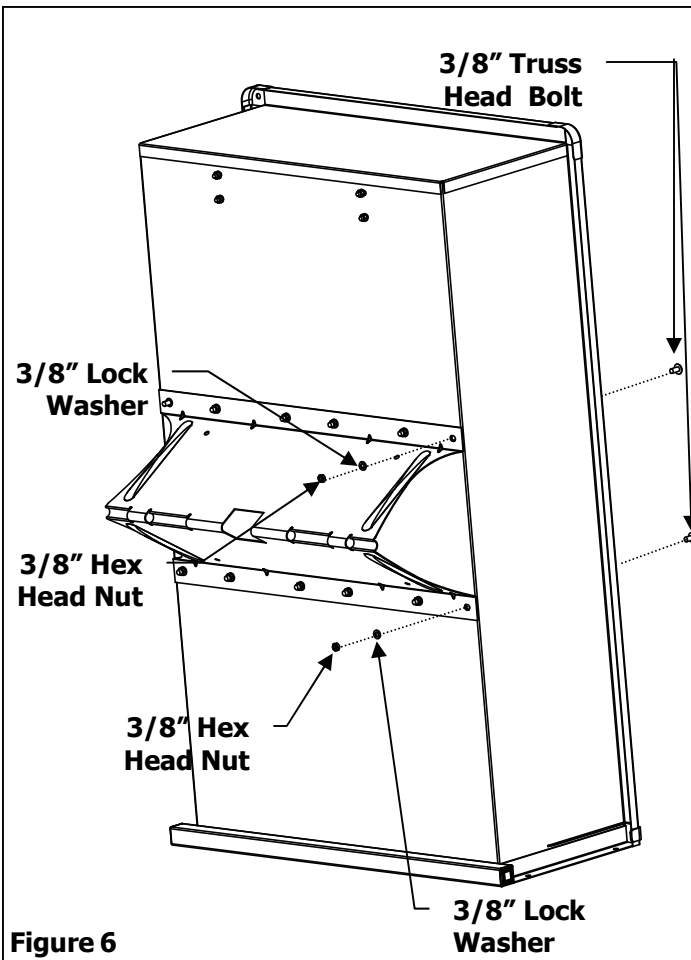

7. Attach Pedestal to bottom front of Body. Use 5/16" x 3/4" Truss Head Bolts from inside. On the bottom side, use 5/16" Lock Washers and secure with 5/16" Hex Head Nuts. See Figure 7.

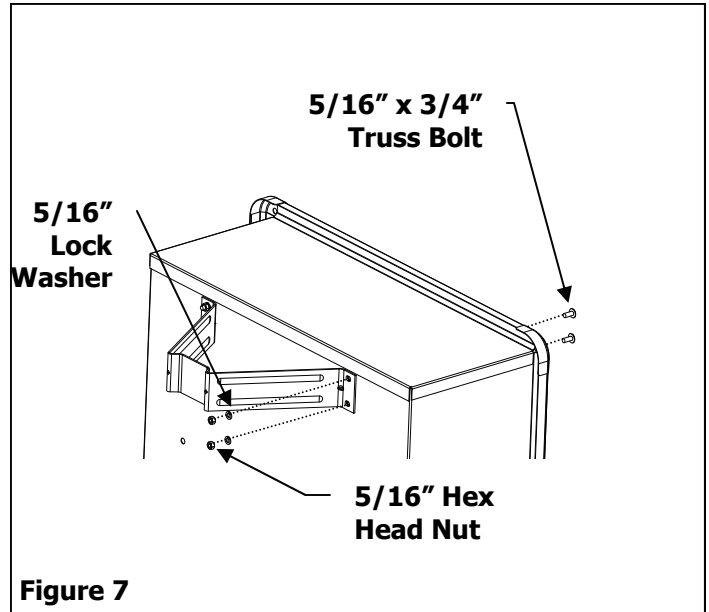

8. Move Body to flat position with Undercarriage and Pedestal face up. Slide Axle halfway through Undercarriage. Place Tow Bar into center slot on Undercarriage, locking latch to Pedestal then slide the Axle through the holes in the Tow Bar then all the way through the Undercarriage. See Figure 8.

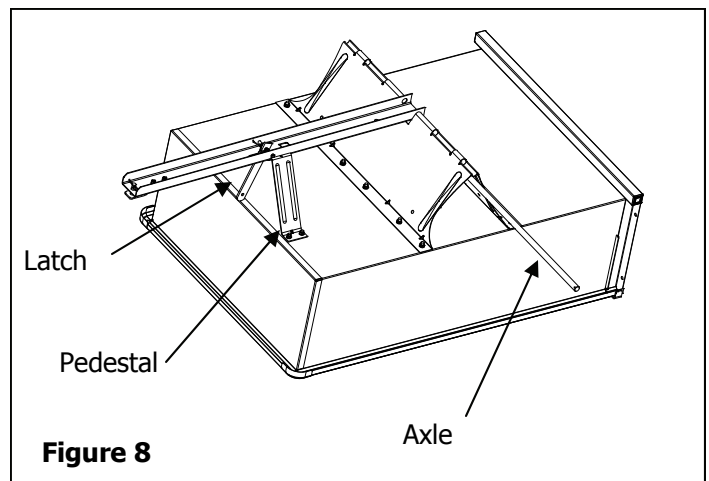

9. Place 3/4" Flat Washer one on each side of Axle next to Undercarriage. Next place Wheel onto Axle. Place another 3/4" Flat Washer on outside of wheel. Secure Wheel in place by inserting Cotter Pin through hole in the end of Axle and spreading the legs of the Cotter Pin outward. Repeat the Wheel attachment step for the other wheel. Two extra 3/4" Flat Washers are included, if needed to be used as spacers. See Figure 9.

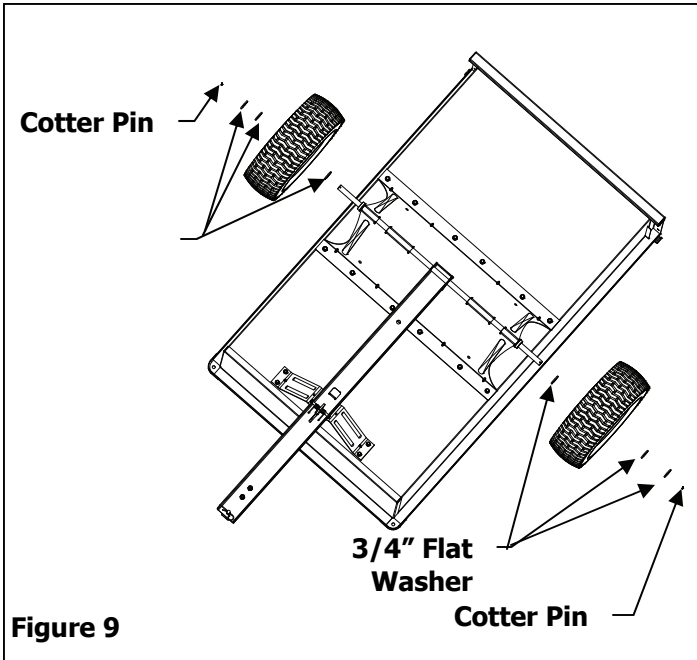

10. Turn Cart to an upright position, then attach Tow Bar to Hitch of tractor, placing Clevis Pin through Clevis Plate Hole and securing with Hitch Pin Clip.

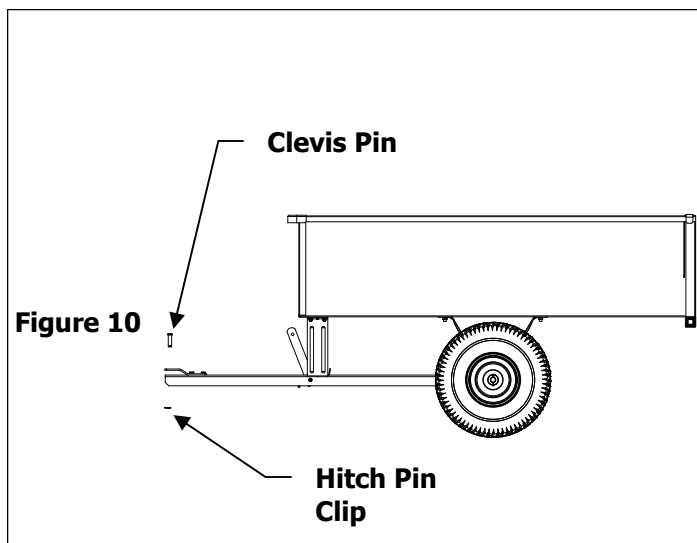

Operation

- TO DUMP - Pull Latch toward lawn tractor and Cart Body will tilt back to dump position.
- TO RETURN TO PULLING POSITION - Push down on front edge of Cart Body until Latch engages and secures to Tow Bar.
- Tractor speed should be governed by weight of load. The heavier the load, the slower the speed for safe operation.

Maintenance Instructions

- Keeping the cart clean and dry will prolong the unit's life.
- Grease Wheels at regular intervals, at least once every six months, more frequently if used regularly.
- Should rust develop, sand lightly then paint area with enamel paint.
- Check tire pressure at regular intervals. Proper inflation will prolong the life of tires (see side of tire for inflation amount).

Parts and Support

STOP *Please do not return this product to the store prior to contacting Precision.*

At Precision Products, Inc. our goal is to deliver quality, value and outstanding service. If for any reason our product does not meet your expectations, please contact us and we will take care of any problem you may have with this unit.

When ordering replacement parts please have the model number, part description, part number, inspector number and date on carton available so that we can best serve you.

1 (800) 225-5891

www.precisionprodinc.com

**Precision Products Inc.
316 Limit St.
Lincoln IL 62656**

← 25

10 ———

20 ———

Ref No.	Part No.	Qty.	Description
1	5515GY	1	Body
2	5502GY	1	Tow Bar
3	5629	1	Axle
4	5547	2	Wheel (Knobby)
5	1262	2	Cotter Pin
6	5631GY	1	Tailgate
7	1264	6	3/4" Flat Washer
8	4630GY	1	Pedestal
9	5630GY	1	Undercarriage
10	1243GY	1	Clevis Plate
11	1265GY	1	Latch
12	1242	1	1/4" x 3" Spacer Tow Bar
13	4497	1	Spring
14	1586	4	5/16" x 3/4" Truss Head Bolt

Ref No.	Part No.	Qty.	Description
15	4552	12	3/8" x 3/4" Truss Head Bolt
16	1273	12	3/8" Hex Head Nut
17	1248	2	5/16" x 3/4" Hex Head Bolt
18	1275	6	5/16" Hex Head Nut
19	1274	12	3/8" Lock Washer
20	1276	6	5/16" Lock Washer
21	4466	1	1/4" x 3-1/2" Hex Head Bolt
22	1778	1	1/4" Reverse Lock Nut
23	1840	1	1/2" x 1-3/4" Hitch Pin
24	1042	1	#14 Clevis Pin Clip
25	4751	2	1-1/2" x 1-1/2" Tube Plug

The limited warranty set forth below is given by Precision Products, Incorporated with respect to new merchandise purchased and used in the United States, its possessions and territories.

Precision Products, Incorporated warrants the product (s) listed against defects in material and workmanship, and will at our option, repair or replace, free of charge, any part found to be defective in materials or workmanship. This limited warranty shall only apply if this product has been assembled, operated, and maintained in accordance with the owner's manual furnished with the product, and has not been subject to misuse, abuse, neglect, accident, improper maintenance, alteration, vandalism, theft, fire, water, or damage because of other peril or natural disaster.

Normal wear parts or components thereof are subject to separate terms as follows: All normal wear parts or component failures will be covered on the product for a period of one year. Parts found to be defective within the warranty period will be replaced at our expense. Our obligation under this warranty is expressly limited to the replacement or repair, at our option, of parts found to be defective in material and workmanship.

Contacting Service

Warranty parts replacements are available, only with **Proof of Purchase**, through our Customer Service Department. Call **1 (800) 225-5891**

This limited warranty does not provide coverage in the following cases:

1. Routine maintenance items such as lubricants and filters.
2. Normal deterioration of the exterior finish due to use or exposure.
3. Transportation and/or labor charges.

No implied warranty, including any implied warranty of merchantability of fitness for a particular purpose, applies after the applicable period of expressed written warranty above as to the part as identified below. No other expressed warranty whether written or oral, except as mentioned above, given by any person or entity, including a dealer or retailer, with respect to any product, shall bind Precision Products, Inc. During the period of the warranty, the exclusive remedy is repair or replacement of the product as set forth above.

The provisions as set forth in this warranty provide the sole and exclusive remedy arising from the sale.

Precision Products, Inc. will not be liable for incidental or consequential loss or damage including, without limitation, expenses incurred for substitute or replacement lawn care services or for rental expenses to temporarily replace a warranted product.

Some states do not allow the exclusion or limitation of incidental or consequential damages, or limitations on how long an implied warranty lasts, so the above exclusions or limitations may not apply to you.

During the warranty period, the exclusive remedy is replacement of the part. In no event shall recovery of any kind be greater than the amount of the purchase price of the product sold. Alteration of safety features of the product shall void this warranty. You assume the risk and liability for loss, damage, or injury to you and your property and/or to others and their property arising out of the misuse or inability to use this product.

This limited warranty shall not extend to anyone other than the original purchaser or to the person for whom it was purchased as a gift.

Local Law to this Warranty

This limited warranty gives you specific legal rights, and you may also have other rights which vary from state to state.

Warranty Period

The Warranty period stated below begins with the **Proof of Purchase**. Without the proof of purchase, the Warranty period begins from the date of manufacture.

Trailer Dump Cart Warranty Period

The warranty period for this unit is as follows: All parts are covered for one year from date of sale.