

# OPERATION AND PARTS MANUAL



## ST3050D SUBMERSIBLE PUMP

Revision #4 (01/11/23)

To find the latest revision of this  
publication, visit our website at:  
[www.multiquip.com](http://www.multiquip.com)



**THIS MANUAL MUST ACCOMPANY THE EQUIPMENT AT ALL TIMES.**

**PROPOSITION 65 WARNING**

---



## **ST3050D Submersible Pump**

Proposition 65 Warning .....	2
Safety Information .....	4-7
Specifications .....	8
General Information .....	9
Components .....	10
Application (Float Switches) .....	11
Control Boxes .....	12
Installation (CB200) .....	13
Control Boxes .....	14
Pump Wiring Diagram .....	15
Transformer Wiring (CB200) .....	16
Wiring Diagram (CB200) .....	17
3-Phase Power Installation (CB200) .....	18-19
Setup (CB200) .....	20-21
Installation (MCP102/104) .....	22
Wiring Diagram (MCP102/104) .....	23
Operation.....	24-26
Troubleshooting .....	27
Explanation Of Code In Remarks Column.....	28
Suggested Spare Parts .....	29

## **Component Drawings**

Pump Assembly.....	30-33
Electric Motor Assembly.....	34-35

### **NOTICE**

Specifications and part numbers are subject to change without notice.

# SAFETY INFORMATION

Do not operate or service the equipment before reading the entire manual. Safety precautions should be followed at all times when operating this equipment. Failure to read and understand the safety messages and operating instructions could result in injury to yourself and others.



## SAFETY MESSAGES

The four safety messages shown below will inform you about potential hazards that could injure you or others. The safety messages specifically address the level of exposure to the operator and are preceded by one of four words: **DANGER**, **WARNING**, **CAUTION** or **NOTICE**.

## SAFETY SYMBOLS

**!** **DANGER**

Indicates a hazardous situation which, if not avoided, **WILL** result in **DEATH** or **SERIOUS INJURY**.

**!** **WARNING**

Indicates a hazardous situation which, if not avoided, **COULD** result in **DEATH** or **SERIOUS INJURY**.





**!** **CAUTION**

Indicates a hazardous situation which, if not avoided, **COULD** result in **MINOR** or **MODERATE INJURY**.

**NOTICE**

Addresses practices not related to personal injury.

Potential hazards associated with the operation of this equipment will be referenced with hazard symbols which may appear throughout this manual in conjunction with safety messages.

Symbol	Safety Hazard
	Burn hazards
	Electric shock hazards
	Rotating parts hazards
	Pressurized fluid hazards

# SAFETY INFORMATION

## GENERAL SAFETY

### CAUTION

- **NEVER** operate this equipment without proper protective clothing, shatterproof glasses, respiratory protection, hearing protection, steel-toed boots and other protective devices required by the job or city and state regulations.



- Avoid wearing jewelry or loose fitting clothes that may snag on the controls or moving parts as this can cause serious injury.

- **NEVER** operate this equipment when not feeling well due to fatigue, illness or when under medication.



- **NEVER** operate this equipment under the influence of drugs or alcohol.



- **ALWAYS** clear the work area of any debris, tools, etc. that would constitute a hazard while the equipment is in operation.

- No one other than the operator is to be in the working area when the equipment is in operation.

- **DO NOT** use the equipment for any purpose other than its intended purposes or applications.

### NOTICE

- This equipment should only be operated by trained and qualified personnel 18 years of age and older.

- Whenever necessary, replace nameplate, operation and safety decals when they become difficult read.

- Manufacturer does not assume responsibility for any accident due to equipment modifications. Unauthorized equipment modification will void all warranties.

- **NEVER** use accessories or attachments that are not recommended by Multiquip for this equipment. Damage to the equipment and/or injury to user may result.

- **ALWAYS** know the location of the nearest fire extinguisher.



- **ALWAYS** know the location of the nearest first aid kit.



- **ALWAYS** know the location of the nearest phone or **keep a phone on the job site**. Also, know the phone numbers of the nearest **ambulance, doctor and fire department**. This information will be invaluable in the case of an emergency.



# SAFETY INFORMATION

## PUMP SAFETY

### DANGER

- **NEVER** operate the equipment in an explosive atmosphere or near combustible materials. An explosion or fire could result causing severe **bodily harm or even death.**



### WARNING

- Accidental starting can cause severe injury or death. **ALWAYS** place the ON/OFF switch in the OFF position.
- **DO NOT** place hands or fingers inside pump when pump is running.
- **NEVER** disconnect any **emergency or safety devices.** These devices are intended for operator safety. Disconnection of these devices can cause severe injury, bodily harm or even death. Disconnection of any of these devices will void all warranties.
- **Risk of Electric Shock** - This pump has not been investigated for use in swimming pool or marine areas.



### CAUTION

- **DO NOT** restrict the flow of the discharge hose as it may cause the pump to overheat.
- Be careful of discharge hose whipping under pressure.
- **ALWAYS** check pump oil level only when pump is cool. Expansion due to heat may cause hot oil to spray from the oil plug when the oil plug is removed. The possibility of severe scalding may exist.

### NOTICE

- **ALWAYS** place the pump in an upright position on a platform before using. The platform will prevent the pump from burrowing itself on soft sand or mud.
- **NEVER** operate pump on its side.
- **DO NOT** allow the pump to freeze in water.
- **NEVER** leave an open pump chamber unattended.
- **ALWAYS** keep the machine in proper running condition.

- **DO NOT** attempt to thaw out a frozen pump by using a torch or other source of flame. Application of heat in this manner may heat the oil in the seal cavity above the critical point, causing pump damage.
- **DO NOT** pump water with a temperature greater than 140°F (60°C).
- **DO NOT** pump liquids containing acid or alkali.
- **ALWAYS** check strainer before pumping. Make sure strainer is not clogged. Remove any large objects, dirt or debris from the strainer to prevent clogging.
- **ALWAYS** use a large basket strainer when pumping water that contains large debris.
- **ALWAYS** flush pump (clean) after use when pumping water concentrated with heavy debris. It is very important to always flush the pump before turning it off to prevent clogging.
- Fix damage to machine and replace any broken parts immediately.
- **ALWAYS** store equipment properly when it is not being used. Equipment should be stored in a clean, dry location out of the reach of children and unauthorized personnel.
- **NEVER** lubricate components or attempt service on a running machine.
- **NEVER** run pump *dry*.
- **ALWAYS** allow the machine a proper amount of time to cool before servicing.
- Keep machine in proper running condition.

## ELECTRICAL SAFETY

### DANGER

- The electrical voltage required to operate pump can cause severe injury or even death through physical contact with live circuits. **ALWAYS** disconnect electrical power from pump before performing maintenance on pump.



### NOTICE

- **ALWAYS** make certain that the voltage supplied to the pump is correct. Always read the pump's nameplate to determine what the power requirements are.

# SAFETY INFORMATION

## Power Cord/Cable Safety

### DANGER

- **NEVER** stand in water while AC power cord is connected to a live power source.
- **NEVER** use **damaged** or **worn** cables or cords. Inspect for cuts in the insulation.
- **NEVER** grab or touch a live power cord or cable with wet hands. The possibility exists of **electrical shock, electrocution or death**.
- Make sure power cables are securely connected to the motor's output receptacles. Incorrect connections may cause electrical shock and damage to the motor.

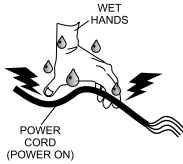

### WARNING

- **NEVER** attempt to use the power cord as a lifting or lowering device for the pump.

### NOTICE

- **ALWAYS** make certain that proper power or extension cord has been selected for the job. See Cable Selection Chart in this manual.

## Grounding Safety

### DANGER

- **ALWAYS** make sure pump is grounded.
- **NEVER** use gas piping as an electrical ground.
- **ALWAYS** make sure that electrical circuits are properly grounded to a suitable earth ground (ground rod) per the National Electrical Code (NEC) and local codes before operating generator. **Severe injury or death by electrocution** can result from operating an ungrounded motor.

### AVERTISSEMENT

- Risques de chocs électriques. Cette pompe est alimentée en électricité au moyen d'un conducteur et d'une fiche d'alimentation de terre. Afin de réduire les risques de chocs électriques, s'assurer que la pompe est uniquement connectée à des boîtiers de protection de mise à la terre correctement enterrés.

## Control Box Safety

### DANGER

- **ALWAYS** have a qualified electrician perform the control box installation. The possibility exists of electrical shock or electrocution.

### NOTICE

- **ALWAYS** mount control box in a vertical position protected from harsh environmental elements.

## LIFTING SAFETY

### CAUTION

- When raising or lowering of the pump is required, always attach an adequate rope or lifting device to the correct lifting point (handle) on the pump.

### NOTICE

- **DO NOT** lift machine to unnecessary heights.
- **NEVER** lift the equipment while the electric motor is running.

## TRANSPORTING SAFETY

### NOTICE

- **ALWAYS** shut down pump before transporting.
- **ALWAYS** tie down equipment during transport by securing the equipment with rope.

## ENVIRONMENTAL SAFETY/DECOMMISSIONING

- **DO NOT** pour waste or oil directly onto the ground, down a drain or into any water source.
- Contact your country's Department of Public Works or recycling agency in your area and arrange for proper disposal of any electrical components, waste or oil associated with this equipment.



- When the life cycle of this equipment is over it is recommended that the pump casing and all other metal parts be sent to a recycling center

Metal recycling involves the collection of metal from discarded products and its transformation into raw materials to use in manufacturing a new product.

Recyclers and manufacturers alike promote the process of recycling metal. Using a metal recycling center promotes energy cost savings.

# SPECIFICATIONS

Table 1. Specifications	
<b>Model</b>	ST3050D
<b>Type</b>	Submersible Trash Pump
<b>Suction and Discharge Size</b>	3.00 in. (76 mm.)
<b>Maximum Pumping Capacity</b>	270 gallons/minute (1,022 liters/minute)
<b>Max. Solids Diameter</b>	2.00 in. (51 mm.)
<b>Max. Lift</b>	25 ft. (7.62 meters)
<b>Max. Head</b>	86 ft. (26.00 meters)
<b>Power</b>	5 HP (3.75 Kw)
<b>Voltage Phase</b>	230/460 3ø
<b>Starting Amps</b>	77 @ 230 VAC 39 @ 460 VAC
<b>Running Amps</b>	14.2 @ 230 VAC 7.1 @ 460 VAC
<b>Control Box Required</b>	Yes
<b>Thermal Overload Protection</b>	Yes
<b>Rotation</b>	Counterclockwise <sup>1</sup>
<b>Mechanical Oil Seal Capacity</b>	180 cc. (.18 Liters) <sup>2</sup>
<b>Impeller Clearance</b>	.012 -.025 in. (.304 - .635 mm.)
<b>RPM (Speed)</b>	3,550 ± 30
<b>Power Cable Length</b>	50 FT. (15.24 Meters)
<b>Dimensions (Dia x Height)</b>	10.2 x 26.8 in. (25.9 X 68 cm.)
<b>Dry Net Weight</b>	120 lbs. (54 Kg.)

1 Motor Rotation – Upon start-up, the pump "kicks" in the opposite direction of motor rotation. The correct rotation is counter-clockwise (CCW) as viewed from the impeller end of the pump. Rotation direction for 3-phase pumps is changed by reversing two of the power leads.

2 Mechanical Oil Seal – Use a good grade 10 weight non-detergent hydraulic oil (i.e. Shell Turbo 32 or equivalent). Fill oil cavity 75% to 85% full (allow air space for expansion).



## GENERAL INFORMATION

---

The Multiquip Model ST3050D submersible pump is designed to pump water and is used for the draining (de-watering) of swimming pools, well casings construction sites, cofferdams, manholes, transformer vaults and excavations.

A vortex type impeller is attached to the output shaft of a 5.0 HP electric motor which provides adequate power for general purpose pumping. This submersible pump is supplied complete with an electric power cable, and a discharge port located at the top of the pump which accepts a 3-inch hose.

This pump is ideal for portability because of its light weight and carrying handle. For reliability and long life, a mechanical seal provides shaft sealing, with an oil chamber separating the pump section from the motor.

The pump when in use, should be installed as free standing (upright position) on its strainer base. A 3-inch discharge hose (not supplied) should be connected to the discharge port located on top of the pump. The discharge hose should be adequately supported to avoid stress on the pump.

For maximum water flow, the discharge hose should be kept as short as possible, and with minimum elevation above the pump. Remember as the length and/or height of the discharge hose is increased, the flow of water will be reduced. Also any reduction in the hose size, and any fittings such as valves or outlet nozzles, will restrict the water flow.

To avoid back-siphonage when the pump is switched off, ensure that the end of the discharge hose is installed above the water level at the final discharge point.

When the pump is switched off, the water remaining in the hose will run back through the pump. This can be avoided by placing a non-return valve in the hose nearest the pump.

**NEVER** use this submersible pump to pump flammable liquids or operate in a explosive or flammable environment.

Avoid using this pump in conditions where mud, grit, silt or other debris are present. These conditions could cause blockage and cause excessive pump wear.

**DO NOT** install the pump directly into an area where there is a heavy build-up of mud, grit, silt or debris. If this condition is present, install the pump on a platform before operating.

This pump must always be positioned on a platform in an upright position. **NEVER** operate the pump by a suspended rope. To prevent large solids from entering the pump, install a wire mesh screen or similar barrier around the pump.

If the pump was used to pump water containing mud, silt, use clean water to flush out the pump after each use.

**DO NOT** allow the pump to run dry, as this will damage the pump. During maintenance, dry running is permissible but only for a few seconds.

**NEVER** lift the pump by its electrical power cord. **ALWAYS** lift the pump by its carrying handle or attached a rope to carrying handle.

A pump fully submerged pump in liquid will not freeze, unless the liquid freezes. **DO NOT** allow a partially submerged pump to freeze. The expansion of water freezing in the volute may crack the pump, causing expensive repairs. If there is any danger of the pump being subjected to freezing temperatures, Lift the pump from water and allow it to drain thoroughly.

If the pump jams or the pump rotor locks for any reason, disconnect the pump from the power source immediately. Allowing the pump motor to cycle ON and OFF under an overload condition can burn out the motor.

When replacement of nuts and bolts is required, use only recommended parts as referenced in the parts section of this manual. This pump uses metric threads. **DO NOT** use English measurement threads.

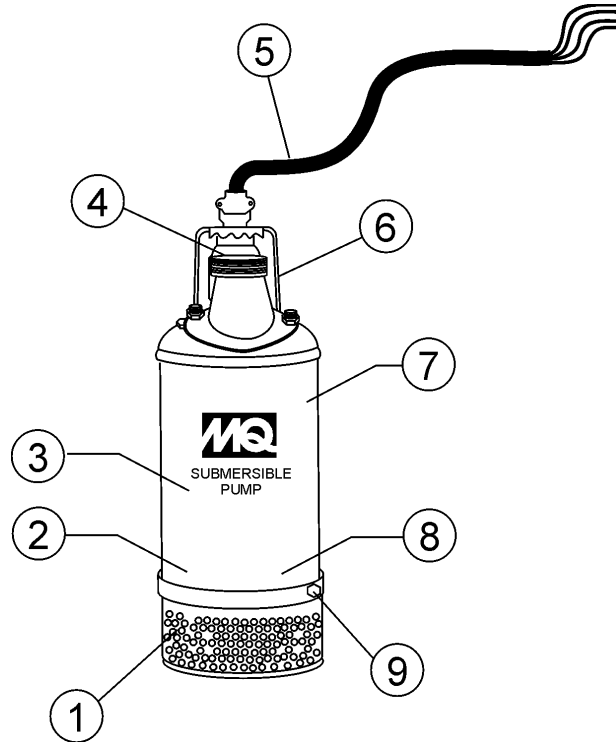

**Figure 1. Submersible Pump Components**

Figure 1 shows general components for the ST3050D submersible pump.

1. **Strainer Base** — This strainer base is made of stainless steel which is resistant to hardware corrosion. **DO NOT** pump large objects or debris with this pump. This pump is for pumping water only. For dewatering purposes, always place the strainer base on a platform.
2. **Volute/Impeller** — Impellers are constructed of high-chrome ductile iron to minimize wear and prolong service life.
3. **Electric Motor** — This unit utilizes a three-phase, 230/460 VAC, 5.0 HP electric motor. Consult with a licensed electrician before connecting motor to a power source. Observe all city and local safety codes.
4. **Discharge Port** — Connect a 3-inch hose to this port. Remember to adequately support the discharge hose to avoid stress on the pump.
5. **AC Power Cable** — This unit is supplied with a 50 ft. (15.24 meters) AC power cable. Always check the cable for signs of wear. **NEVER** use a defective power cable. Replace the cable immediately if the cable is worn or defective
6. **Carrying Handle** — Always carry the submersible pump by its handle. **NEVER** carry the pump by its power cord. Carrying or lifting the pump by the power cord, will cause undue stress on the cord, and ultimately the cord will become dislodged from the pump.
7. **Thermal Overload Protection** — This pump will require the use of an external control box with a thermal overload protection device that will shut-down the motor in the event of high operating temperatures. The motor will automatically restart once the temperature returns to an acceptable operating temperature.
8. **Mechanical Oil Seal** — This oil filled seal provides lubrication when running the pump dry. **NEVER** run the pump dry. Running the pump dry will cause severe damage to the pump.
9. **Mechanical Oil Seal Plug** — Remove this plug to check and add hydraulic oil (Shell 32 or equivalent) to the oil cavity. This oil protects the mechanical seal. Oil cavity should be full enough to cover seal spring.

# APPLICATION (FLOAT SWITCHES)

## FLOAT SWITCH THEORY

There is a tilt-sensitive mercury switch hermetically sealed within each float. As the liquid level (water) rises or falls, the float changes its angle until the mercury switch makes (close) or breaks (open) the circuit.

The length of cord between the float and point of attachment determines the amount of water to be pumped.

Contact Multiquip Sales Department to order float switches.

## FLOAT SWITCH (DUAL)

Float switches (Figure 2) are used for the unattended operation of the submersible pump. The ST3050D pump requires the use of a control box to perform this function.

Shown in Figure 2 is an example of a dual float control switch application.

The Model ST3050D submersible pump requires one each of the Model SW-1WOP float type mercury switches. These switches have a pumping range level between 5.5~18 feet (1.67~5.5 meters). All float switch connections are bare wire (no plug). The ST3050D submersible pump must use the CB 200 Control Box when float switches are required for the job application. The MCP102/104 control boxes do not have float switch capability.

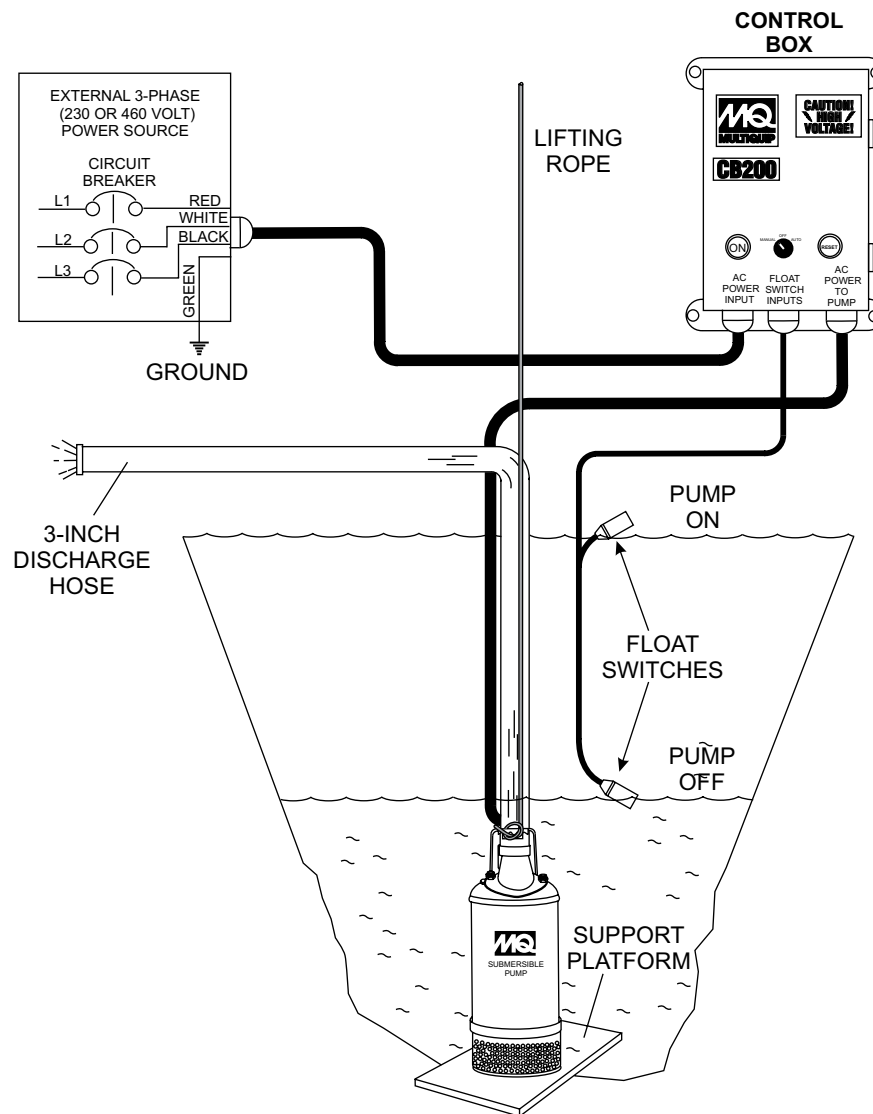

Figure 2. Dual Float Control Switch

# CONTROL BOXES

## CONTROL BOXES

Control boxes (Figure 3) are available for remote control and thermal shut-down capability for the submersible pump. These water resistant control boxes provide electronic overload protection, watertight housing and glands to prevent water from leaking into the box, and a float switch interface.

There are various control box models to choose from, reference Table 2 for the model that meets your pumping requirements.

Contact Multiquip sales department to order control boxes as listed in Table 2.

**NOTICE**

ALWAYS have a qualified licensed electrician perform the installation of the control box.



Figure 3. Electrical Control Box (CB200)

Table 2. Control Box Specifications				
Model No.	Voltage Type	UL/CSA Listed	Thermal Overload Protection	Float Switch Capability
CB200	230/460 VAC Three-Phase	YES	YES	YES
MCP102	230 VAC Three-Phase	YES	YES	NO
MCP104	460 VAC Three-Phase	YES	YES	NO

# INSTALLATION (CB200)

To place the ST3050D submersible pump into operation, requires the use of a control box. The control box contains the necessary electronics (electronic overload module, float switch connections and 230/460 voltage transformer) to operate the pump. Remember this control box contains hazardous voltages. Disconnect all sources of power before installing or servicing. There exists the possibility of electrocution, electric shock or burn, which can cause severe bodily harm or even death!

## NOTICE

Control box should only be installed or serviced by a licensed electrician or qualified personnel.

## CONTROL BOX MOUNTING

Mount the control box in an upright vertical position. Make sure the control box is securely fastened to a flat surface, that is free of dust, dirt, moisture or any elements that may contaminate or erode the electronic components of the control box.

## 3-Phase Power Installation (Input)

The ST3050D submersible pump requires 230/460 3-phase power for normal operation. The pump is shipped from the factory in the 230 VAC configuration. To change the voltage setting from 230 VAC to 460 VAC refer to the transformer wiring section.

If you cannot determine what your pump's power requirements are, look at the vendor supplied identification name tag attached to the pump or please contact Multiquip's Service/Technical Assistance department.

## NOTICE

Applying incorrect power (voltage phasing) to the submersible pump can cause severe damage to the pump. Please make sure that the correct voltage and phase are transferred to the pump at all times.

## POWER CORD REQUIREMENTS

When routing the three phase power via a power cord to the control box, ALWAYS use the correct wire size. Please reference Table 3 (Cord Length/Wire Size) to determine the correct wire size. Incorrect wire size can adversely affect the performance of the pump.

Table 3. Cord Length and Wire Size

AMPS	50 FT.	100 FT.	150 FT.
6	16 AWG	16 AWG	14 AWG
8	16 AWG	14 AWG	12 AWG
10	16 AWG	14 AWG	12 AWG
12	14 AWG	14 AWG	12 AWG
14	14 AWG	12 AWG	10 AWG
16	12 AWG	12 AWG	10 AWG

## FLOAT SWITCH INSTALLATION (CB200)

1. Remove the float switch input connector housing, then route the float switch wires through the cable gland on the control box. Attach the wires to the float switch terminal block as indicated by Table 4. Reference Figure 7 and Figure 8.

Table 4. Float Switch Connections

FLOAT SWITCH	FLOAT SWITCH TERMINAL BLOCK NUMBER
START	TERMINALS 1 AND 2
STOP	TERMINALS 3 AND 4

2. Tighten the connector housing to ensure a tight fit between the cord and the connector body. This will prevent the cable from pulling out of the terminal block and also prevent moisture from entering the control box.
3. Determine the length of the float switch wires, then secure float switch wires to pump discharge hose.

# CONTROL BOXES

## 230/460 VAC VOLTAGE SELECTION

The ST3050D submersible pump is factory set at 230 VAC. To change the voltage from 230 VAC to 460 VAC, perform the following:

1. Remove the four retaining screws that secure the power cord gland assembly to the pump casing, and pull the 230 VAC female plug (Figure 4) from the pump's cavity.
2. Unplug the 230 VAC female plug from the male motor windings plug and insert the 460 VAC female plug into male motor windings plug.

3. Reinstall the power cord gland assembly back into the pump's cavity. Make sure that the gland is seated correctly. This will prevent any connector pins from bending or breaking.
4. Insert the four retaining screws and tighten securely.

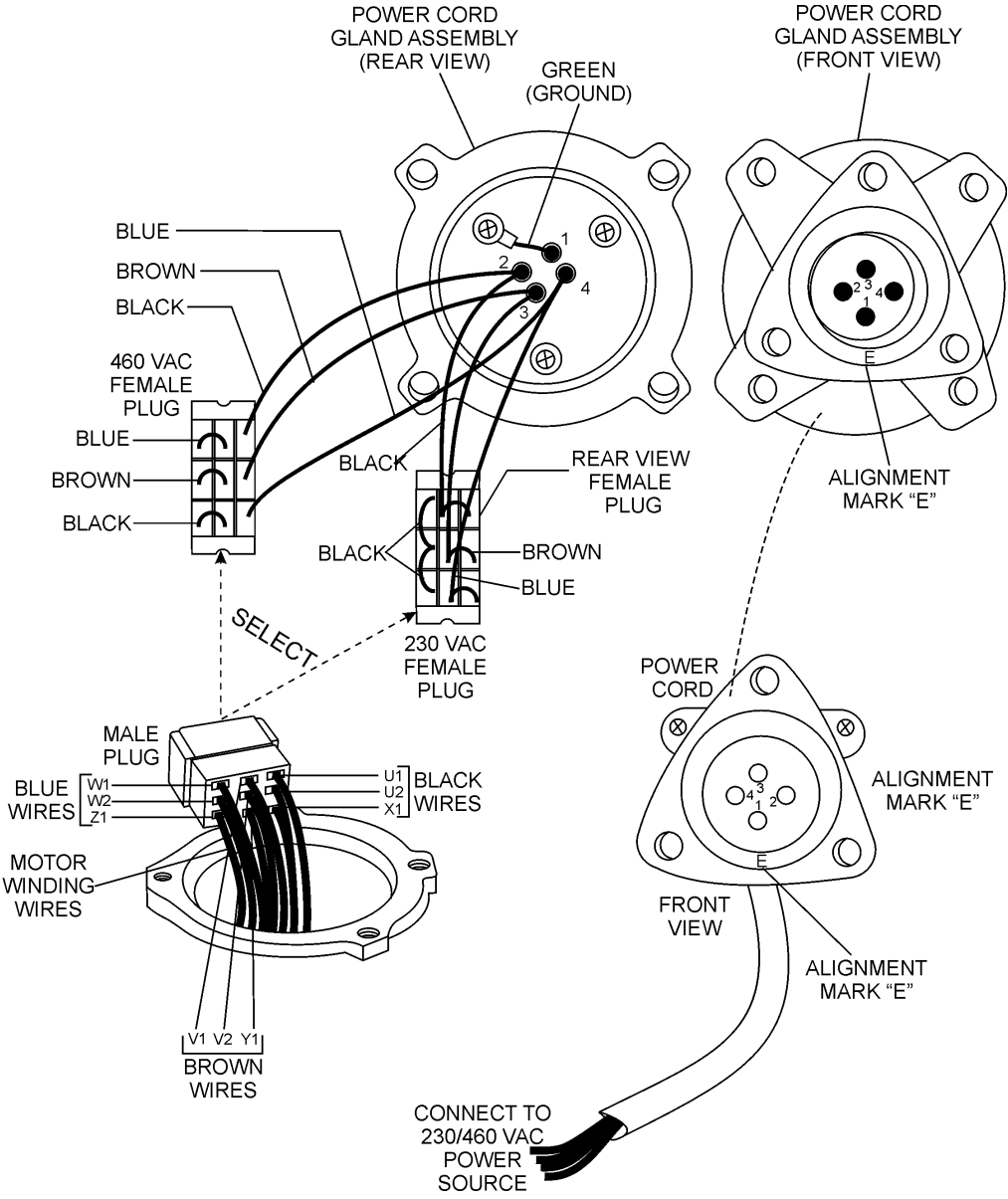
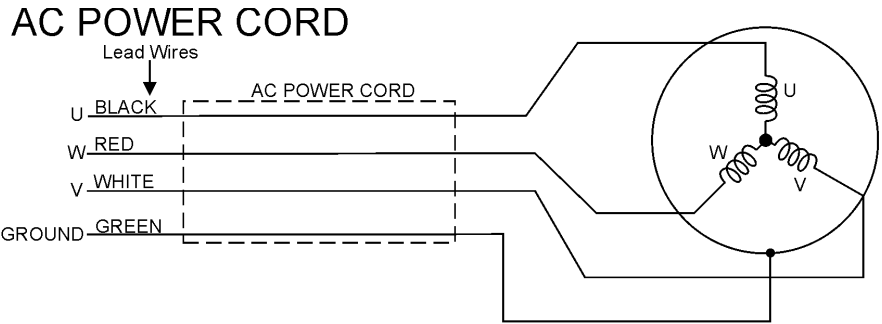
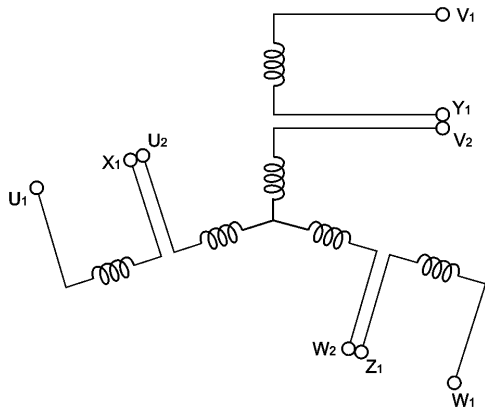

Figure 4. 230/460 VAC Pump Voltage Selection

# PUMP WIRING DIAGRAM



## MOTOR WIRING



## 230 VAC WIRING CONFIGURATION

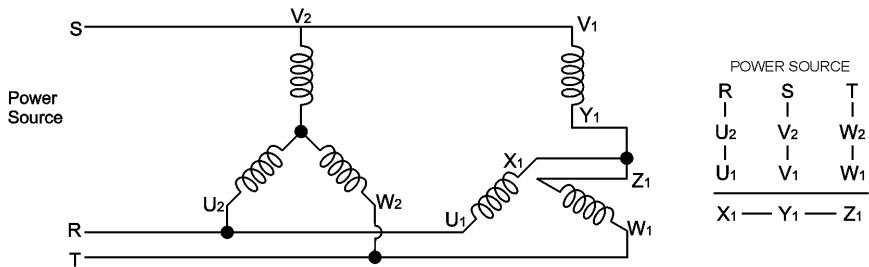

## 460 VAC WIRING CONFIGURATION

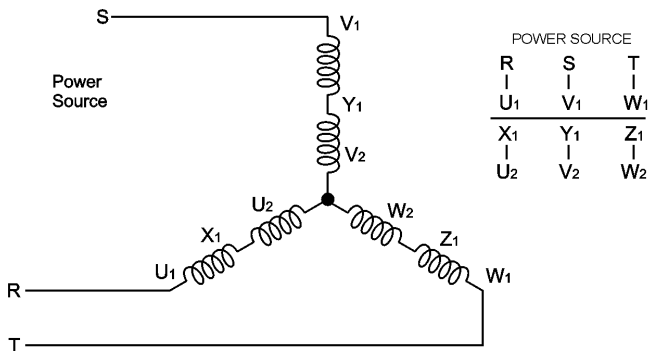

Figure 5. Pump Wiring Diagram

# TRANSFORMER WIRING (CB200)

## TRANSFORMER 230/460 VOLTAGE SETTINGS

Pump motors are factory set at 230 VAC. The transformer (Figure 6) of this control box must be set to the voltage requirements of the pump in use. Refer to the attached wiring diagram located inside the "Control Box" or reference Figure 7 and Figure 8. Use the two supplied jumper tabs to set the transformer to the required output voltage.

### NOTICE

Transformer settings are for CB200 control box only!

### WARNING

ALWAYS make sure that the transformer is set to the correct output voltage. Incorrect transformer output voltage settings can cause severe damage to the pump.

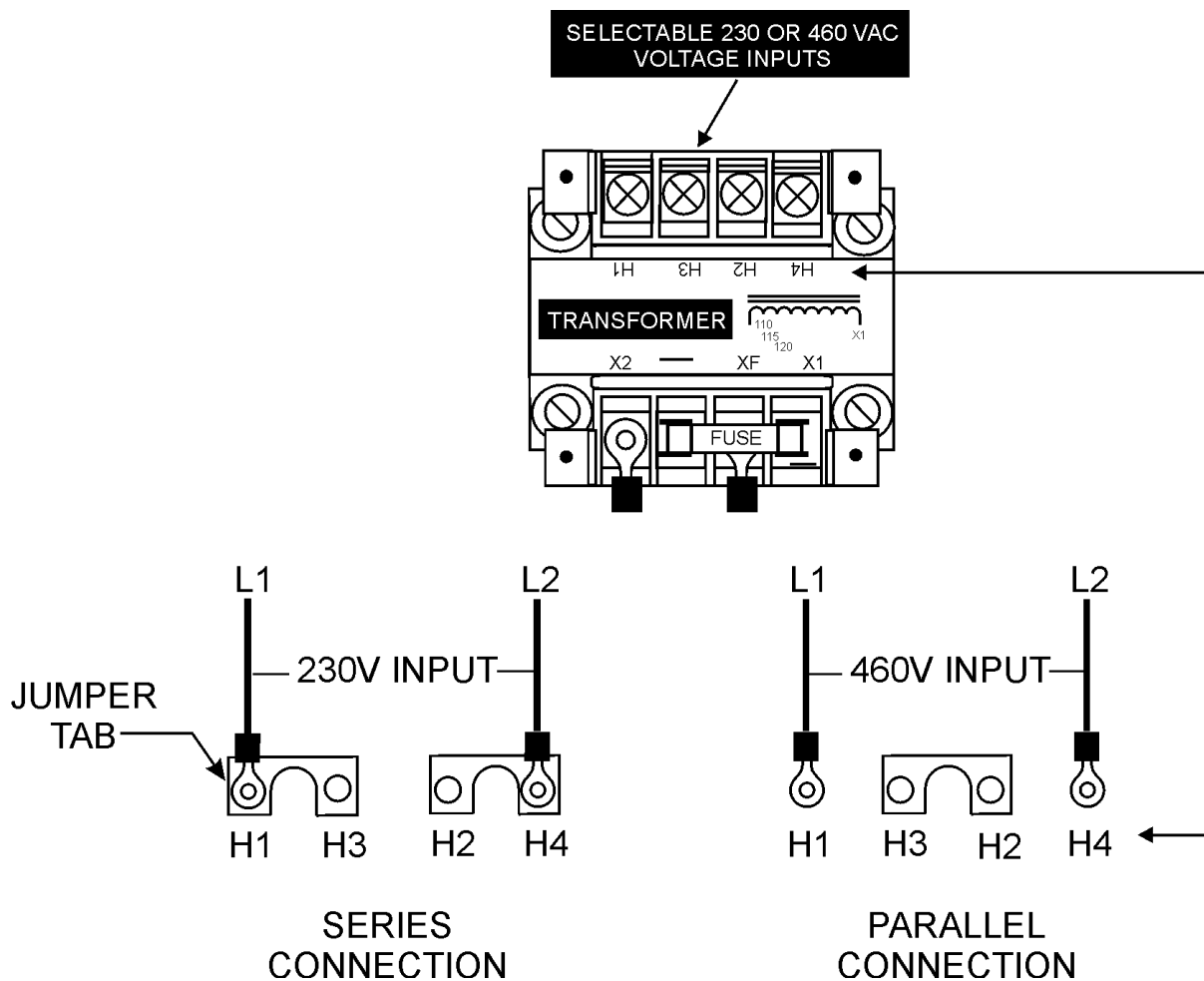

Figure 6. Transformer AC Voltage Settings (Jumper Tabs)



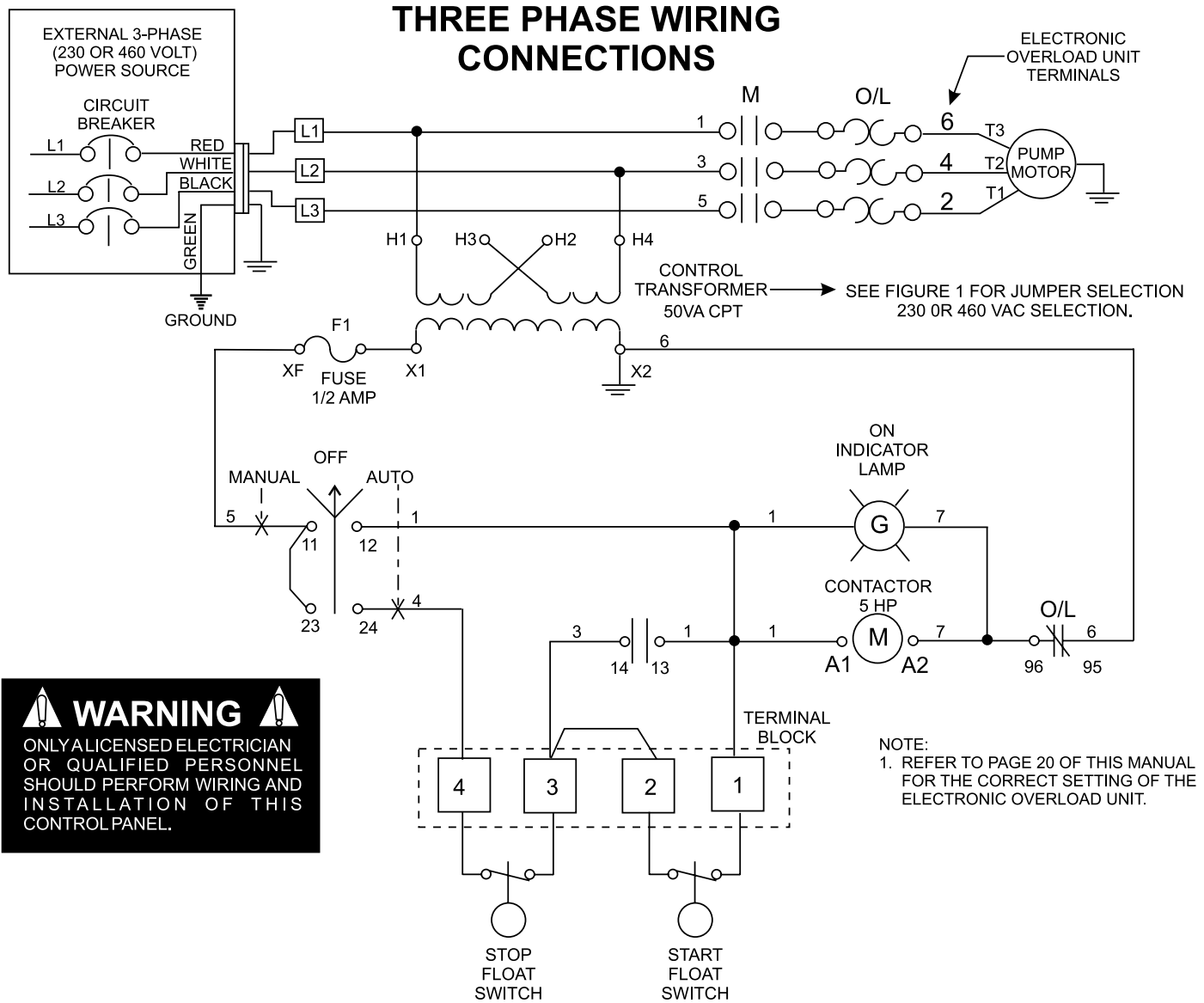

Figure 7. Control Box Wiring Diagram

**NOTICE**  
Float switch connections are for use with the CB200 Control Box only!

## 3-PHASE POWER INSTALLATION (CB200)

### 3-PHASE POWER CORD INSTALLATION (INPUT TO BOX)

1. The three phase input power cord should have four wires. Each wire is color coded. The colors are RED, WHITE, BLACK and GREEN.
2. Remove the 3-phase AC input connector housing from the control box, then route the three phase input power cable through the cable gland on the control box. Attach the wires to the AC terminal block inside the control box as indicated by Table 5 and Figure 8.

**Table 5. 3-Phase AC Input Power Connections**

Cable Wire Color	AC Terminal Block
RED	L1
WHITE	L2
BLACK	L3
GREEN	GROUND

3. Tighten the connector housing to ensure a tight fit between the power cord and the connector body. This will prevent the cable from pulling out of the terminal block and also prevent moisture from entering the control box.

#### NOTICE

It is recommended that the power being supplied to the control box ALWAYS be connected to a circuit breaker or a quick disconnect switch. This safety feature allows for quick removal of power from the control box in the event of an emergency.

4. Connect the other end of the 3-phase input power cord to the voltage source. Remember to provide a means of disconnecting the power from the control box (circuit breaker or quick disconnect switch). Also make sure to provide a good earth ground to the control box.

### 3-PHASE POWER INSTALLATION (OUTPUT TO PUMP)

1. The three phase output power cord should have four wires. Each wire is color coded. The colors are RED, WHITE, BLACK and GREEN.
2. Remove the 3-phase AC output power connector housing on the control box, then route the three phase output power cable through the cable gland on the control box. Attach the wires to the AC terminal blocks on the electronic overload unit as indicated by Table 6 and Figure 8.

**Table 6. 3-Phase AC Output Power Connections**

Cable Wire Color	Electronic Overload Unit Terminal Block
BLACK	2
WHITE	4
RED	6
GREEN	GROUND

#### NOTICE

Electrical connections to the power source should only be performed by a licensed electrician or qualified personnel.

# 3-PHASE POWER INSTALLATION (CB200)

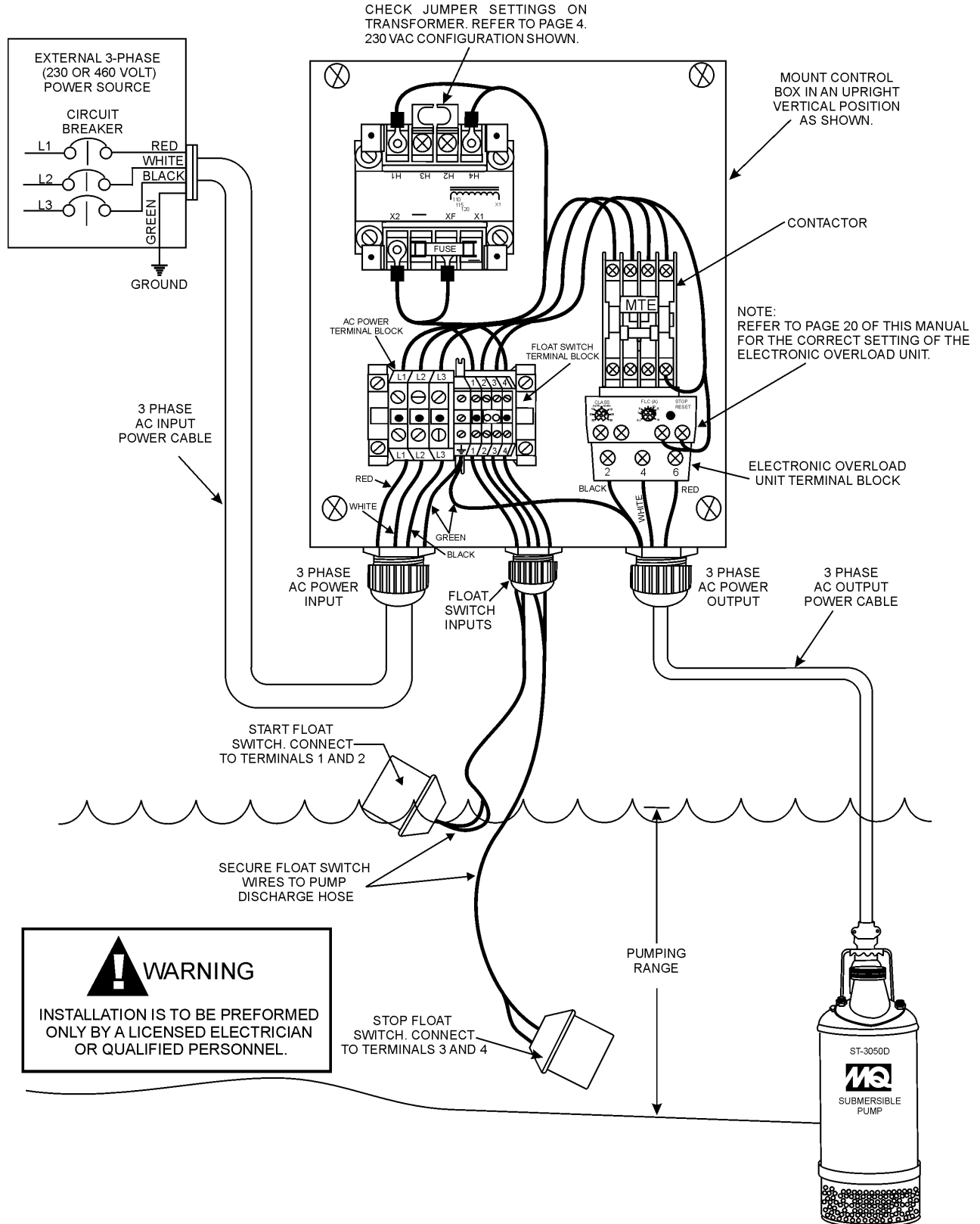

Figure 8. 3-Phase Control Box/Pump System Diagram

## ELECTRONIC OVERLOAD UNIT SETTINGS

### NOTICE

Electronic Overload Unit: Always make sure that the electronic unit supplied with the control box is set to the correct amperage. This overload unit must MATCH the amperage requirements of the pump motor.

Using an electronic overload unit with incorrect settings may result in serious damage to the pump. Refer to the Pump Amperage Requirements Table (Table 7), for the correct overload amperage settings.

There are two dials on the Electronic Overload Unit (Figure 9) that require adjustment to meet the amperage requirement of the pump motor in use.

These dials are located on top of the overload unit and are labeled CLASS and FLC (A).

Use a phillips-head screwdriver to adjust the dials to the correct settings.

### FLC (A) Dial Setting

1. Set the FLC (A) dial pointer (Figure 9) to the correct amperage for the pump motor in use. Use Table 7, to determine the correct amperage setting.

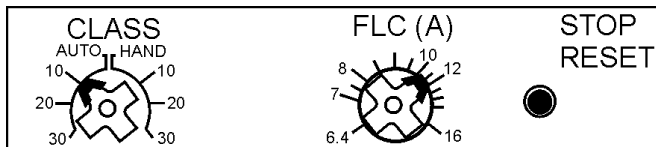

Figure 9. Electronic Overload Unit

Table 7. Pump Motor Amperage Requirements

Pump Model	Control Box	Volts (VAC)	Amps	Overload Unit
ST3050D Three-Phase	CB200	230	14.2	AXE016-6.40-16A
ST3050D Three-Phase	CB200	460	7.1	AXE016-6.40-16A

## CLASS DIAL SETTING

1. Set the CLASS dial pointer (Figure 9) to the HAND position 10. This controls the reset function only. It does not affect the ability of the pump to run with or without float switches.

## RESET OPERATION

This electronic control unit has two modes of reset. The modes are defined as follows:

### MODE 1

When the CLASS dial on the electronic overload module is in the HAND position (manual) the reset button (Figure 10) on the front of the control box must be pushed to reset the unit (restore power) in the event of an overload.



Figure 10. Control Box Reset Button

### MODE 2

When the CLASS dial on the electronic overload module is in the AUTO position (automatic mode) the unit will automatically be reset in the event of an overload.

### NOTICE

All Multiquip control boxes should have the CLASS dial set to the HAND position 10.

## OPERATION

1. From the voltage source set the circuit breaker or quick disconnect switch to the ON position.
2. For manual operation of the pump, place the 3-position operation switch (Figure 11) on the control box in the MANUAL position.

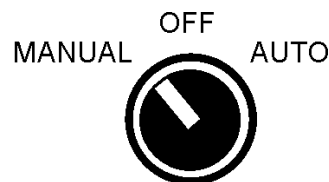

Figure 11. Operation Switch (Manual Position)

3. Verify that the ON indicator (Figure 12) on the control box is LIT. This means that power is being supplied to the control box.



**Figure 12. Control Box Power ON Indicator**

4. In the manual mode the pump will run continuously. Pay close attention when running the pump in this mode. DAMAGE to the pump may occur if pump is not immersed in water.
5. To operate the pump automatically (float switches), place the 3-position operation switch in the AUTO position (Figure 13).

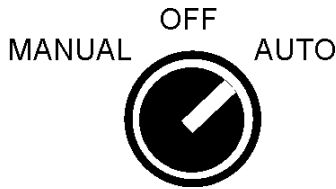

**Figure 13. Operation Switch (Auto Position)**

6. In the AUTO mode the pump will run as long as there is a sufficient amount of water. This amount is determined by the setting of the float switches. The stop float switch contacts will open when the water level is low and power will be removed from the pump's motor.

Once the water level has risen back to the appropriate level the start float switch contacts will close and power will be restored to the pump's motor.

## SHUT-DOWN

1. Place the 3-position operation switch on the control box to the OFF position (Figure 14).

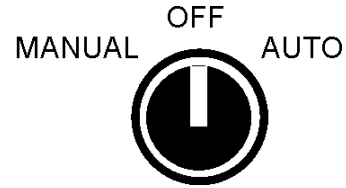

**Figure 14. Operation Switch (OFF Position)**

2. Verify that the control box power ON light is OFF.
3. Turn the circuit breaker or quick disconnect switch to the OFF position.

## INSTALLATION (MCP102/104)

### CAUTION

This control box contains hazardous voltages. Disconnect all sources of power before installing or servicing. There exists the possibility of electrocution, electric shock or burn, which can cause severe bodily harm or even death!

The MCP102 Control Box is to be used only for 230 VAC 3-phase applications and the MCP 104 Control Box is for 460 VAC 3-phase applications. Neither control box has float switch capability.

### POWER CORD REQUIREMENTS

When routing the three phase power via a power cord to the control box, ALWAYS use the correct wire size. Reference Table 3 to determine the correct wire size. Incorrect wire size can adversely affect the performance of the pump.

### CONTROL BOX MOUNTING

Mount the control box in an upright vertical position. Make sure the control box is securely fastened to a flat surface, that is free of dust, dirt, moisture or any elements that may contaminate or erode the electronic components of the control box.

### 3-PHASE POWER CORD (INPUT TO BOX) INSTALLATION

1. The three phase input power cord should have four wires. Each wire is color coded. The colors are RED, WHITE, BLACK and GREEN.
2. Remove the 3-phase AC input connector housing from the control box, then route the three phase input power cable through the cable gland on the control box. Attach the wires to the terminal block on the electronic overload unit inside the control box as indicated by Table 5 and Figure 17.
3. Tighten the connector housing to ensure a tight fit between the power cord and the connector body. This will prevent the cable from pulling out of the terminal block and also prevent moisture from entering the control box.

It is recommended that the power being supplied to the control box ALWAYS be connected to a circuit breaker or a quick disconnect switch. This safety feature allows for

quick removal of power from the control box in the event of an emergency.

4. Connect the other end of the 3-phase input power cord to the voltage source. Remember to provide a means of disconnecting the power from the control box (circuit breaker or quick disconnect switch). Also make sure to provide a good earth ground to the control box.

### ELECTRONIC OVERLOAD SETTING (230 VAC, 3Ø)

1. Using a small flat-blade screwdriver, set the amperage dial pointer on the electronic overload unit to 14.2 amps.

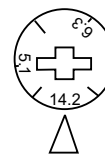

Figure 15. Dial Pointer (14.2 Amps)

### ELECTRONIC OVERLOAD SETTING (460 VAC, 3Ø)

1. Using a small flat-blade screwdriver, set the amperage dial pointer on the electronic overload unit to 7.1 amps.

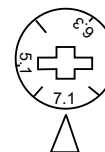

Figure 16. Dial Pointer (7.1 Amps)

### 3-PHASE POWER INSTALLATION (OUTPUT TO PUMP)

1. The three phase output power cord should have four wires. Each wire is color coded. The colors are RED, WHITE, BLACK and GREEN.
2. Remove the 3-phase AC output power connector housing on the control box, then route the three phase output power cable through the cable gland on the control box. Attach the wires to the AC terminal blocks on the electronic overload unit as indicated by Table 6 and Figure 17.

# WIRING DIAGRAM (MCP102/104)

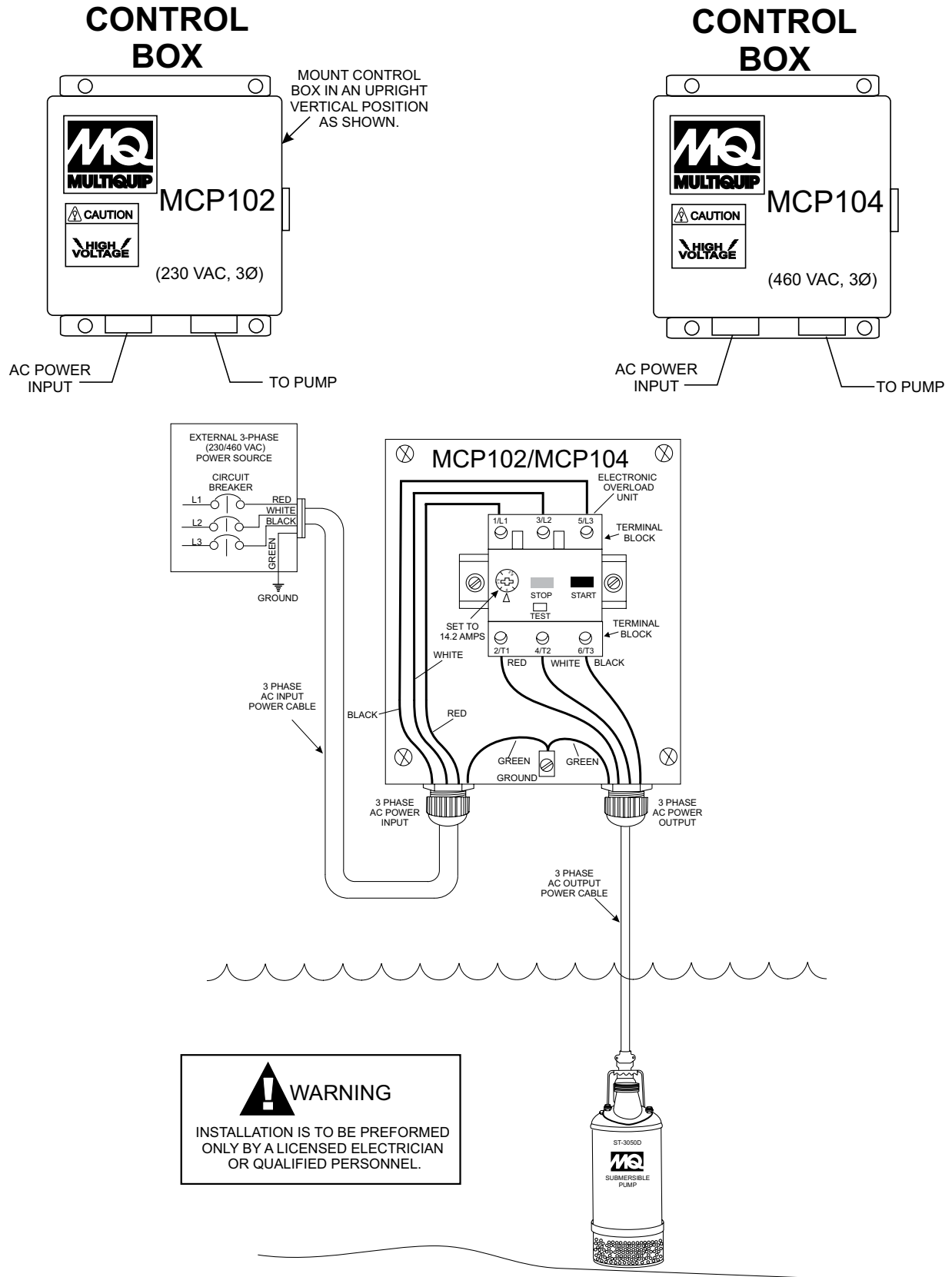
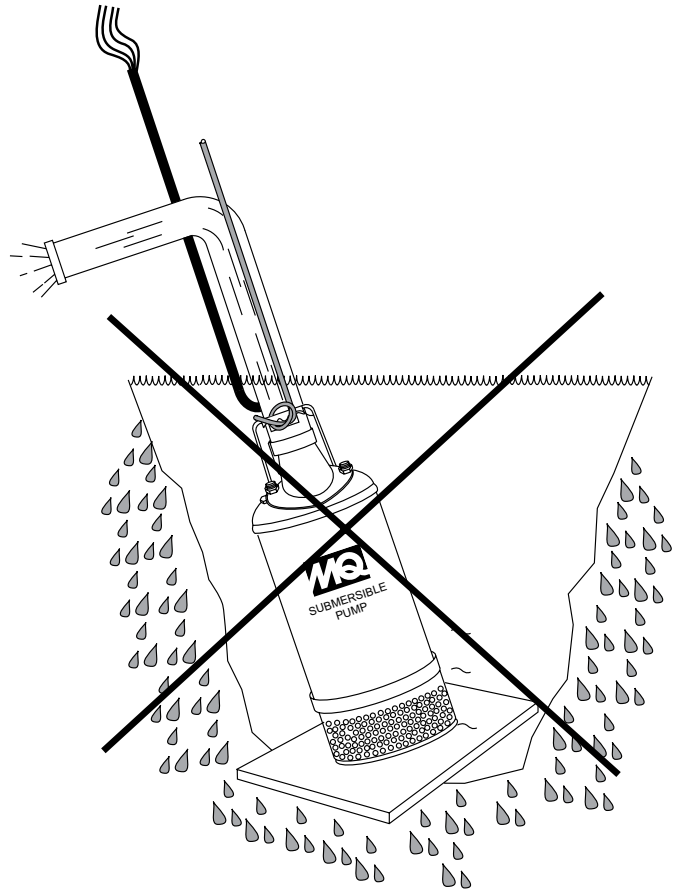
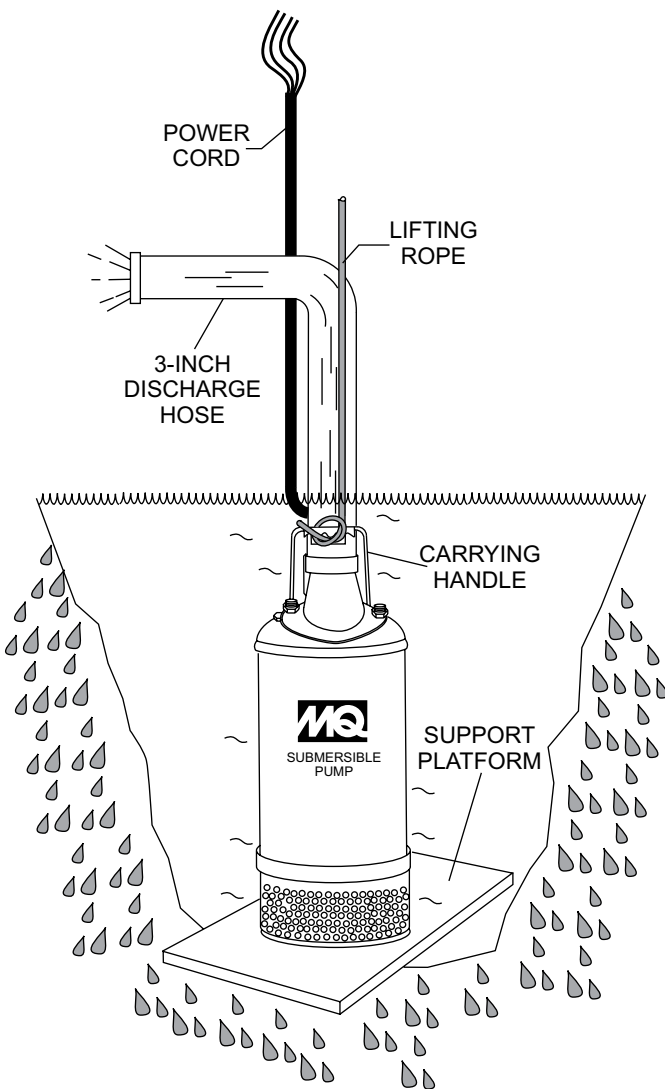

Figure 17. MCP102/104 Control Box Configurations

## OPERATION

1. Attach a suitable lifting cable (rope) to the carrying handle (Figure 18) on the pump and lower the pump into place. For applications where there is an excessive amount of mud, grit or silt, the use of a support platform is desirable. When pumping water from swimming pool type applications where there is little or no debris, the support platform is not required.

2. Make sure the pump is always placed in an upright position, not tilted (Figure 19). Never position the pump directly on a soft, loose bottom. Remember to attain maximum pumping capacity and prevent excessive wear, position the pump so it will not burrow itself into sand or clay.



**Figure 19. Submersible Pump Upright Position (Incorrect)**

3. After the pump has been positioned correctly into place, power can be applied to the pump's electric motor.

**Figure 18. Submersible Pump Upright Position (Correct)**



**! DANGER**



**NEVER** grab or touch a live power cord. **DO NOT** stand in water when connecting the pump's power cord into a voltage source. The possibility exists of electrical shock, electrocution and possibly death!

4. If all of the pump's electrical requirements have been met, insert the power plug on the pump into the power source receptacle.
5. Wait a few seconds and water should begin to flow from the discharge hose.
6. If water is not flowing from the discharge hose or not flowing freely after a few minutes, remove the power from the pump and check the system for leaks.

## PUMP SHUT-DOWN/CLEAN-UP

1. Remove the power from the pump by turning off the circuit breaker or switch that provides power to the pump. Remember to make sure that hands are dry (not wet), and feet are not standing in water when removing disconnecting power from the pump.
2. Using the lifting rope, lift the pump up from its current position. Remove the discharge hose from the discharge port on the pump.
3. Remove all power cables and float switches from the control box. Place cables and float switches in a suitable container where they will not get damaged.
4. If the pump was used to pump mud, grit or silt, flush vigorously with clean water.
5. Remove the pump from the water. Wipe off any mud or debris that might have attached itself to the pump.
6. Store pump in a clean dry place away from dirt and debris.

## LUBRICATION

To check the oil level of the mechanical seal perform the following:

1. Lay the pump (Figure 20) on its side with the oil plug facing upwards.
2. Remove oil fill plug.
3. Visually inspect oil plug hole to verify that oil cavity is full enough to cover seal spring. Check every 300 hours, change hydraulic oil every 6 months (1,000 hours) or as needed.
4. While checking the hydraulic oil level, also check the condition of the hydraulic oil in the seal cavity. Block the opening with a finger and roll pump to one side to drain oil into a small transparent container. If oil is cloudy or has water in it, drain oil from pump cavity and replace hydraulic oil. Check the seal for wear damage.

5. If oil level is low fill with SAE 10 weight non-detergent hydraulic oil (i.e. Shell Turbo 32 or equivalent). Fill oil cavity 75% to 85% full (allow air space for expansion). Pump oil cavity capacity is approximately 180 cc.

## IMPELLER

1. Make sure the clearance between the impeller and the friction disk is approximately .012 - .020 inches (.304 - .508 mm.)
2. If impeller is defective or badly worn, replace impeller immediately.

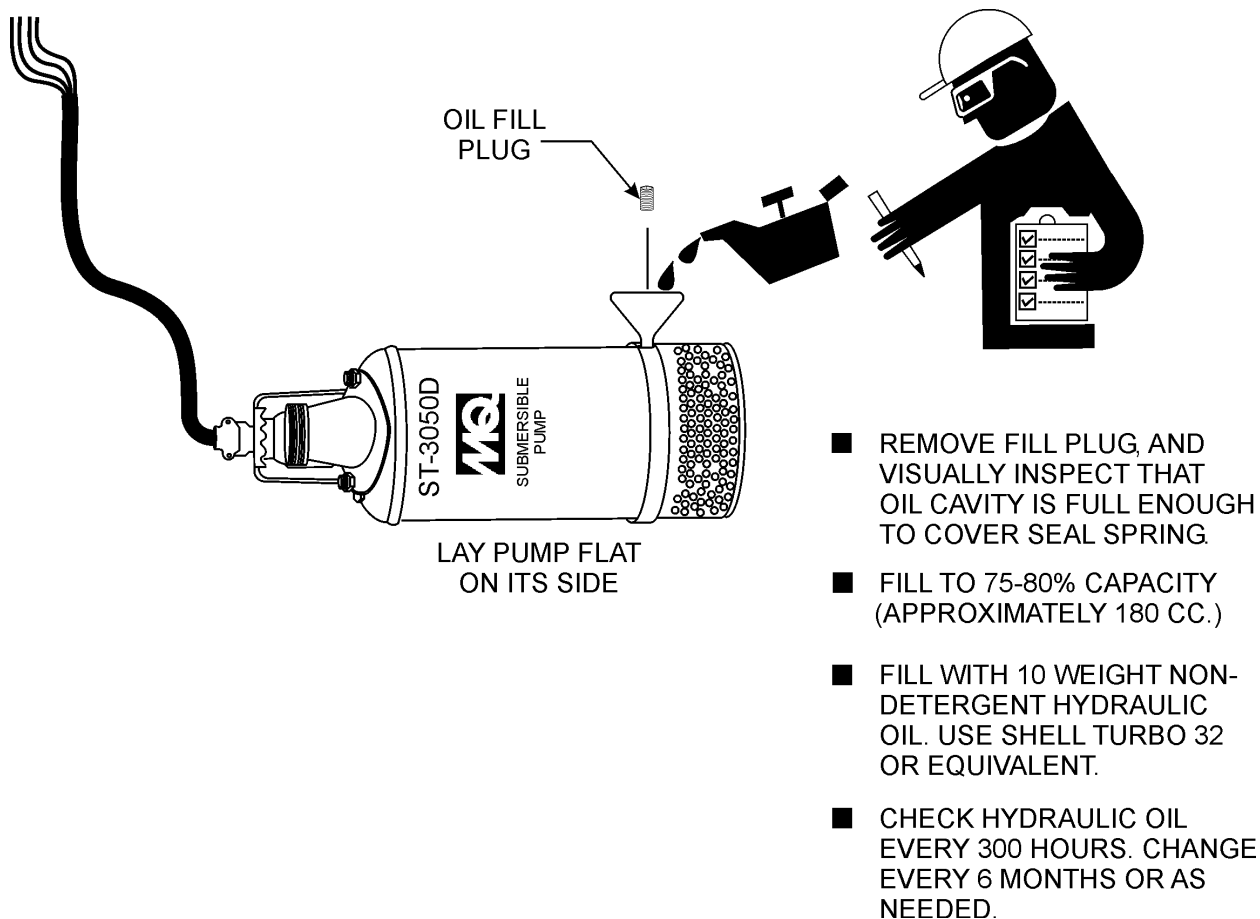

Figure 20. Checking Hydraulic Oil

# TROUBLESHOOTING

Troubleshooting (Pump)		
Symptom	Possible Problem	Solution
Pump Fails To Start	Incorrect voltage/amps?	Check that proper voltage is being supplied to the pump. Also check that there is an adequate amount of current (amps) to run the pump. Check power source circuit breaker.
	Check electrical connections?	If using float switches check wiring, inspect power cord.
	Blown power fuse?	Replace fuse, check cause of blown fuse.
	Impeller locked?	Disconnect power cord and check for clogging and improper impeller clearance. Unclog pump. Check overload protection device.
	Wet motor windings?	Use multimeter to check motor insulation. Insulation resistance must be greater than 15 megaohms. If resistance is low, disassemble pump motor and bake windings to dry them.
	Defective motor and pump bearings?	Check for excessive bearing wear. If worn, replace bearings. Replace motor if defective.
Pump Fails to Deliver Full Output	Twisted or restricted discharge hose?	Lay hose flat unkinked. Remove clog from hose line.
	Clogged pump strainer?	Clean strainer.
	Low voltage?	Use a voltmeter to check voltage while pump is energized. Voltage must be within $\pm 10\%$ . Check power source (no load and load). If an extension cord is used, make sure it has adequate current-carrying capacity for the required length. See Cord Length and Sizes Table.
	Impeller worn?	Replace impeller.
Water in Seal Oil	Defective water seal?	Replace water seal.
	Loose Oil Fill Plug?	Tighten securely.

Performance Curve

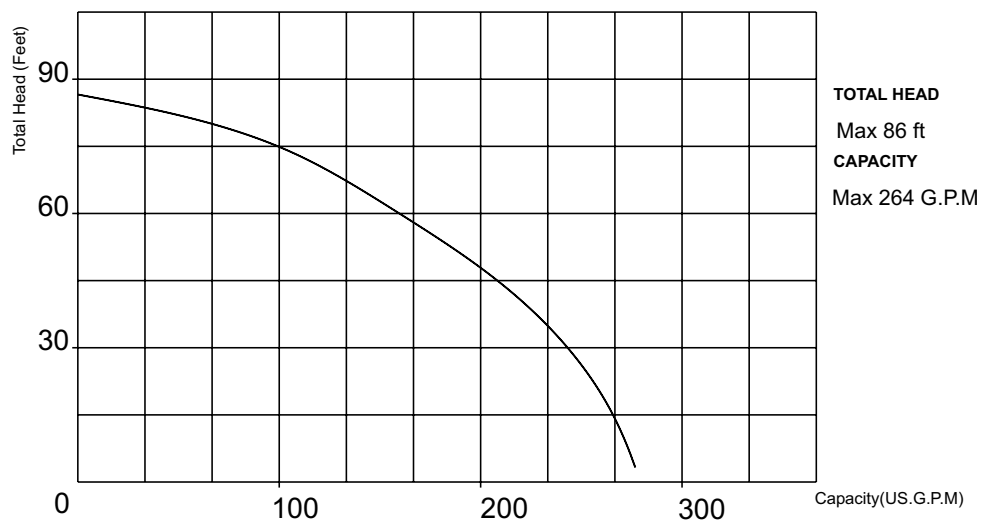

Figure 21. Performance Curve

# EXPLANATION OF CODE IN REMARKS COLUMN

The following section explains the different symbols and remarks used in the Parts section of this manual. Use the help numbers found on the back page of the manual if there are any questions.

**NOTICE**

The contents and part numbers listed in the parts section are subject to change **without notice**. Multiquip does not guarantee the availability of the parts listed.

## SAMPLE PARTS LIST

NO.	PART NO.	PART NAME	QTY.	REMARKS
1	12345	BOLT .....	1	INCLUDES ITEMS W/%
2%		WASHER, 1/4 IN. ....		NOT SOLD SEPARATELY
2%	12347	WASHER, 3/8 IN. ...	1	MQ-45T ONLY
3	12348	HOSE .....	A/R	MAKE LOCALLY
4	12349	BEARING .....	1	S/N 2345B AND ABOVE

### NO. Column

**Unique Symbols** — All items with same unique symbol (@, #, +, %, or >) in the number column belong to the same assembly or kit, which is indicated by a note in the “Remarks” column.

**Duplicate Item Numbers** — Duplicate numbers indicate multiple part numbers, which are in effect for the same general item, such as different size saw blade guards in use or a part that has been updated on newer versions of the same machine.

**NOTICE**

When ordering a part that has more than one item number listed, check the remarks column for help in determining the proper part to order.

### PART NO. Column

**Numbers Used** — Part numbers can be indicated by a number, a blank entry, or TBD.

TBD (To Be Determined) is generally used to show a part that has not been assigned a formal part number at the time of publication.

A blank entry generally indicates that the item is not sold separately or is not sold by Multiquip. Other entries will be clarified in the “Remarks” Column.

### QTY. Column

**Numbers Used** — Item quantity can be indicated by a number, a blank entry, or A/R.

A/R (As Required) is generally used for hoses or other parts that are sold in bulk and cut to length.

A blank entry generally indicates that the item is not sold separately. Other entries will be clarified in the “Remarks” Column.

### REMARKS Column

Some of the most common notes found in the “Remarks” Column are listed below. Other additional notes needed to describe the item can also be shown.

**Assembly/Kit** — All items on the parts list with the same unique symbol will be included when this item is purchased.

Indicated by:

“INCLUDES ITEMS W/(unique symbol)”

**Serial Number Break** — Used to list an effective serial number range where a particular part is used.

Indicated by:

“S/N XXXXX AND BELOW”

“S/N XXXX AND ABOVE”

“S/N XXXX TO S/N XXX”

**Specific Model Number Use** — Indicates that the part is used only with the specific model number or model number variant listed. It can also be used to show a part is NOT used on a specific model or model number variant.

Indicated by:

“XXXXX ONLY”

“NOT USED ON XXXX”

**“Make/Obtain Locally”** — Indicates that the part can be purchased at any hardware shop or made out of available items. Examples include battery cables, shims, and certain washers and nuts.

**“Not Sold Separately”** — Indicates that an item cannot be purchased as a separate item and is either part of an assembly/kit that can be purchased, or is not available for sale through Multiquip.

## SUGGESTED SPARE PARTS

---

### ST3050D SUBMERSIBLE PUMP 1 TO 3 UNITS

Qty.	P/N	Description
1.....	.0203050120.....	AC CORD W/CORD GLAND
1.....	.0203050060.....	MECHANICAL SEAL
1.....	.0203050081.....	OIL SEAL
1.....	.0203050047.....	LINER
1.....	.0203050003.....	IMPELLER
1.....	.0202020004.....	IMPELLER NUT
2.....	.0203050214.....	PACKING
1.....	.0202020157.....	PACKING
1.....	.0202020435.....	PACKING
1.....	.0202020435.....	SPRING WASHER

**PUMP ASSY.**

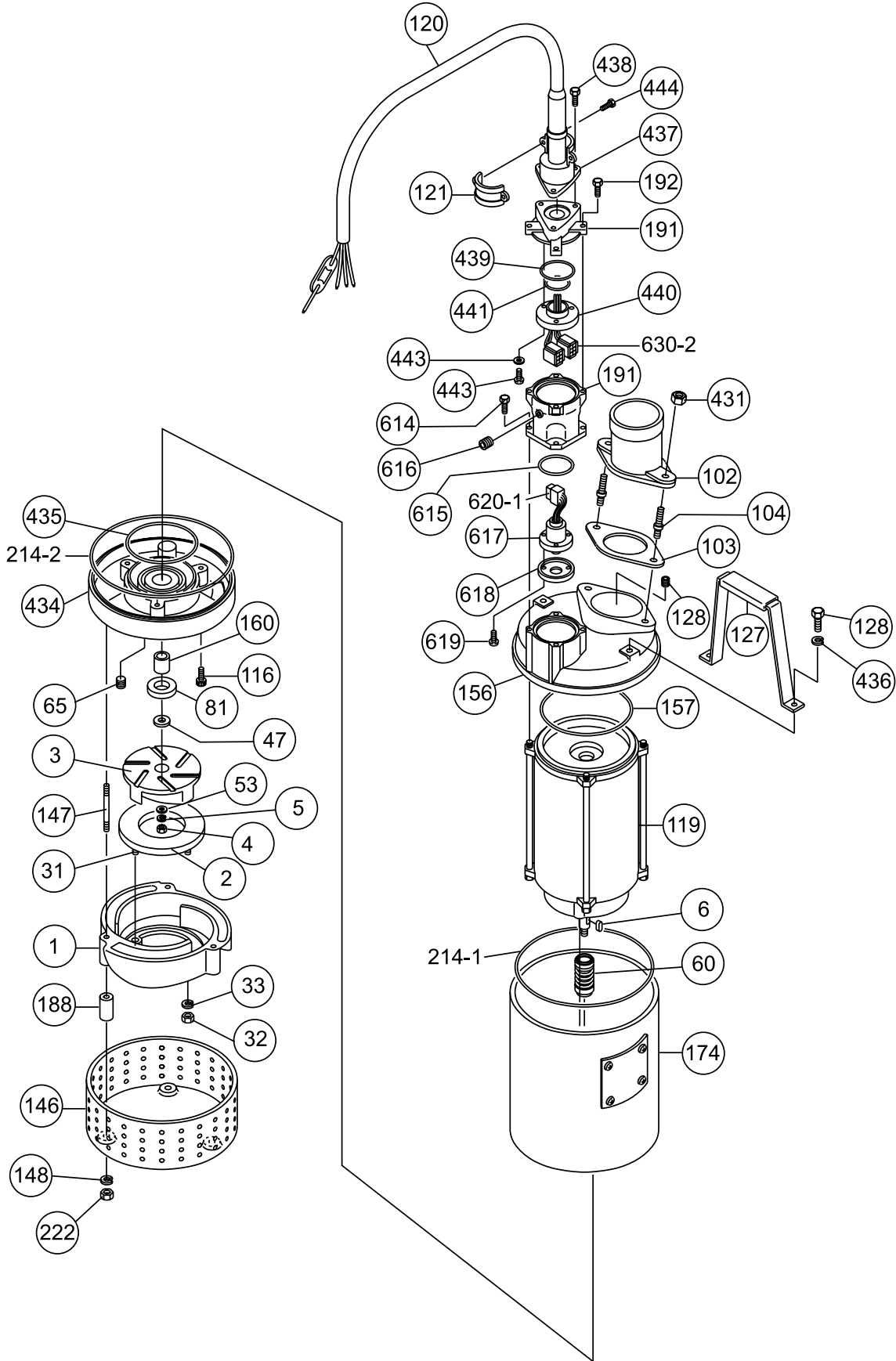

## PUMP ASSY.

---

<u>NO.</u>	<u>PART NO.</u>	<u>PART NAME</u>	<u>QTY.</u>	<u>REMARKS</u>
1	0203050001	CASING	1	
2	0203050002	FRICITION DISC.	1	
3	0203050003	IMPELLER	1	
4	0202020004	IMPELLER NUT	1	
5	0202020005	SPRING WASHER	1	
6	0203050006	IMPELLER KEY	1	
31	0202020031	STUD BOLT	4	
32	0202020032	NUT	4	
33	0202020033	WASHER	4	
47	0203050047	LINER	1	
53	0202020053	WASHER	1	
60	0203050060	MECHANICAL SEAL	1	
65	0202020065	PLUG	1	
81	0203050081	OIL SEAL	1	
102	0203050102	DISCHARGE PORT	1	
103	0203050103	PACKING	1	
104	0203050104	STUD BOLT	2	
116	0202020116	BOLT	3	
119	0203050D119	MOTOR	1	
120	0203050120	AC CORD W/CORD GLAND	1	
121	0202020121	CORD CLAMP	1	
127	0202020127	CARRYING HANDLE	1	
128	0202020128	BOLT	2	
146	0203050146	STRAINER	1	
147	0203050147	STUD BOLT	4	
148	0203050148	SPRING WASHER	4	
156	0203050156	HEAD COVER	1	
157	0202020157	PACKING	1	
160	0203050160	SLEEVE	1	
174	0203050174	OUTER PIPE	1	
188	0203050188	STRAINER SET PIPE	4	
191	0202020191	POWER CORD GLAND CASE	1	
192	0202020192	BOLT	4	
214-1	0203050214	PACKING	1	
214-2	0203050214	PACKING	1	

**PUMP ASSY.**

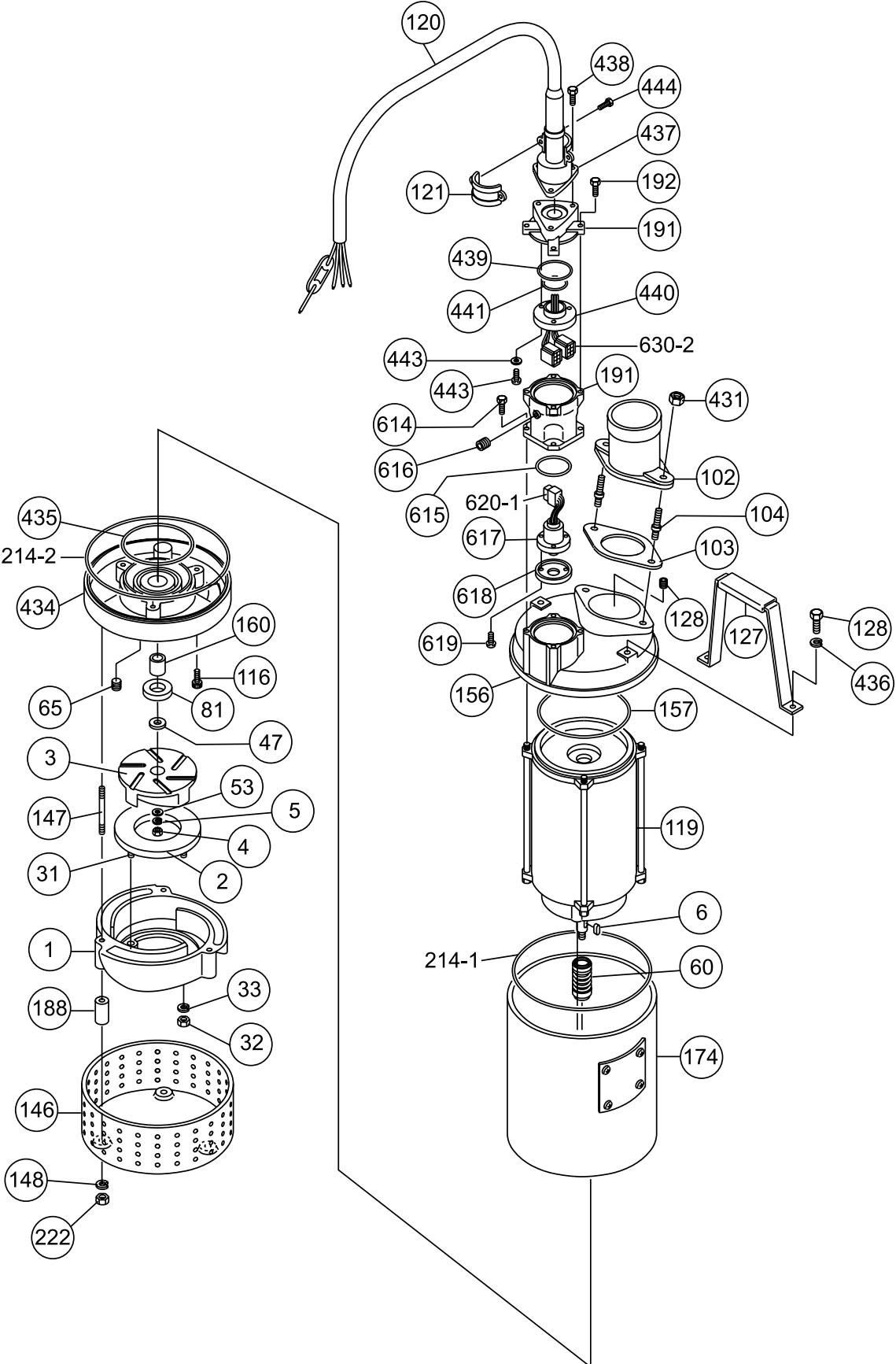



## PUMP ASSY.

---

<u>NO.</u>	<u>PART NO.</u>	<u>PART NAME</u>	<u>QTY.</u>	<u>REMARKS</u>
222	0203050222	NUT	4	
224	0202020224	PLUG	1	
431	0203050431	NUT	2	
434	0203050434	STUFFING BOX	1	
435	0202020435	PACKING	1	
436	0202020436	SPRING WASHER	2	
437	0202020437	CORD GLAND CASE COVER	1	
438	0202020438	BOLT	3	
439	0202020439	PACKING	1	
440	0202020440	CONNECTOR	1	
441	0202020441	PACKING	1	
442	0202020442	BOLT	3	
443	0202020443	WASHER	3	
444	0202020444	BOLT	2	
613	0203050D613	CONNECTOR CASE	1	
614	0203050D614	BOLT	4	
615	0203050D615	PACKING	1	
616	0203050D616	PLUG	1	
617	0203050D617	GLAND RUBBER	1	
618	0203050D618	GLAND METAL	1	
619	0203050D619	BOLT	3	
620-1	0203050D620A	CONNECTOR	1	
620-2	0203050D620B	CONNECTOR	1	

# ELECTRIC MOTOR ASSY.

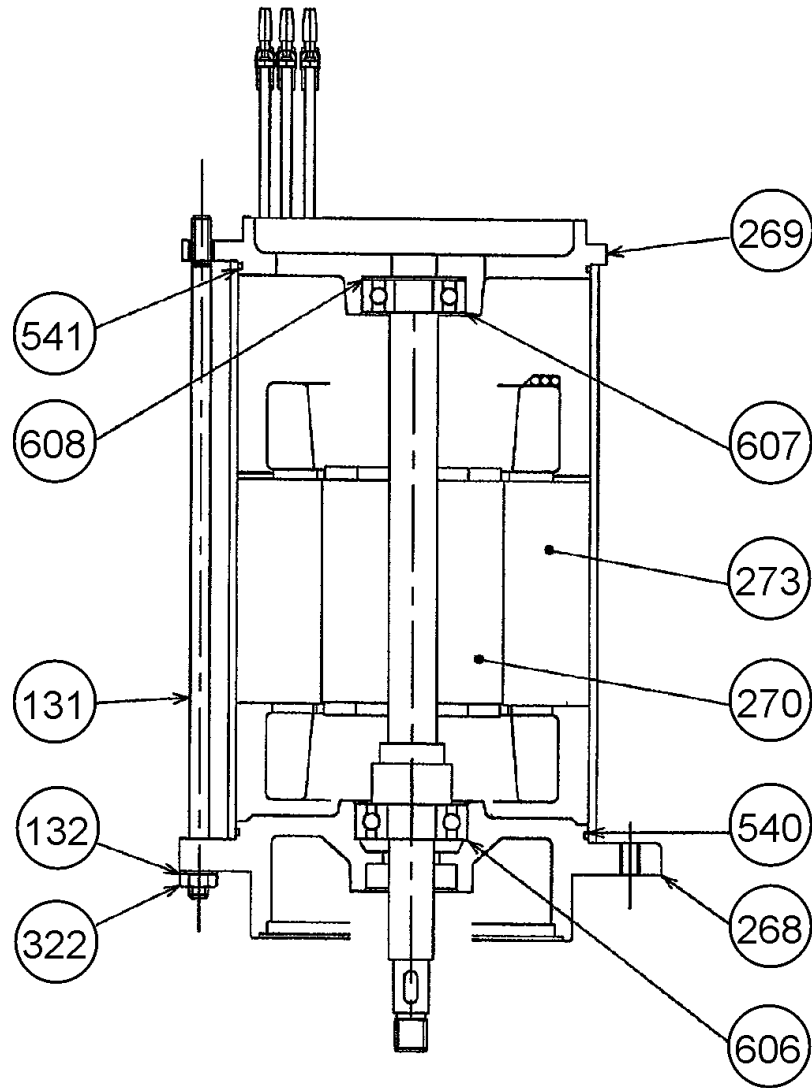

## **ELECTRIC MOTOR ASSY.**

---

<u>NO.</u>	<u>PART NO.</u>	<u>PART NAME</u>	<u>QTY.</u>	<u>REMARKS</u>
131	0203050131	BOLT	4	
132	0202020B132	WASHER, LOCK	4	
268	0203050268	MOTOR A BRACKET	1	
269	0203050269	MOTOR B BRACKET	1	
270	0203050270	MOTOR ROTOR	1	
273	0203050D273	MOTOR STATOR	1	
322	0202020B322	NUT	4	
540	0203050540	A PACKING	1	
541	0203050541	B PACKING	1	
606	0203050606	A BEARING, MOTOR	1	
607	0203050607	B BEARING, MOTOR	1	
608	0202020B608	WASHER, WAVE	1	

# OPERATION AND PARTS MANUAL

## HERE'S HOW TO GET HELP

PLEASE HAVE THE MODEL AND SERIAL  
NUMBER ON-HAND WHEN CALLING

### UNITED STATES

#### *Multiquip Inc.*

(310) 537- 3700  
6141 Katella Avenue Suite 200  
Cypress, CA 90630  
E-MAIL: [mq@multiquip.com](mailto:mq@multiquip.com)  
WEBSITE: [www.multiquip.com](http://www.multiquip.com)

---

### CANADA

#### *Multiquip*

(450) 625-2244  
4110 Industriel Boul.  
Laval, Quebec, Canada H7L 6V3  
E-MAIL: [infocanada@multiquip.com](mailto:infocanada@multiquip.com)

### UNITED KINGDOM

#### *Multiquip (UK) Limited Head Office*

0161 339 2223  
Unit 2, Northpoint Industrial Estate,  
Globe Lane,  
Dukinfield, Cheshire SK16 4UJ  
E-MAIL: [sales@multiquip.co.uk](mailto:sales@multiquip.co.uk)

© COPYRIGHT 2023, MULTIQUIP INC.

Multiquip Inc, the MQ logo are registered trademarks of Multiquip Inc. and may not be used, reproduced, or altered without written permission. All other trademarks are the property of their respective owners and used with permission.

This manual MUST accompany the equipment at all times. This manual is considered a permanent part of the equipment and should remain with the unit if resold.

The information and specifications included in this publication were in effect at the time of approval for printing. Illustrations, descriptions, references and technical data contained in this manual are for guidance only and may not be considered as binding. Multiquip Inc. reserves the right to discontinue or change specifications, design or the information published in this publication at any time without notice and without incurring any obligations.

