



SERVICE PARTS LIST

BULLETIN NO.
54-00-2150

SPECIFY CATALOG NO. AND SERIAL NO. WHEN ORDERING PARTS			REVISED BULLETIN	DATE
M18™ RADIUS™ SITE LIGHT/CHARGER WITH ONE-KEY™				Oct. 2017
CATALOG NO.	2150-20	SERIAL NUMBER	WIRING INSTRUCTION	
		J06A		

See page 2 for available service parts and accessories

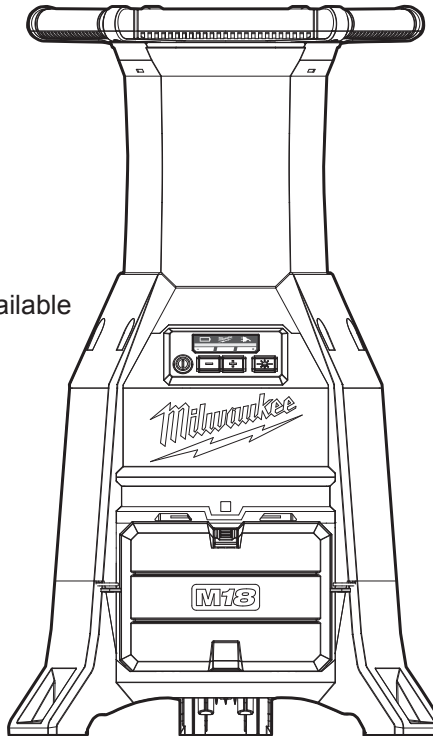

Service for Milwaukee Electric Tool ONE KEY Products can only be performed at this Milwaukee factory Central Repair Center:

**MILWAUKEE ELECTRIC TOOL Central Repair
1013 Sycamore Avenue • Greenwood, MS 38930-7277**

Please send your tool directly to this location for service.

Or

Via e-Service at: www.milwaukeetool.com/e-service
questions, please call 1.800.SAWDUST (1.800.729.3878)

Or

Return it to a MILWAUKEE *factory* Service Center location, freight prepaid and insured.
A copy of the proof of purchase should be included with the return product.

If you have questions please contact Milwaukee Product Service at:
Product Technical Support via phone at: 262.783.8642

Or

Via email at: METProductSupport@milwaukeetool.com

Disassembly is not recommended and could void the warranty.

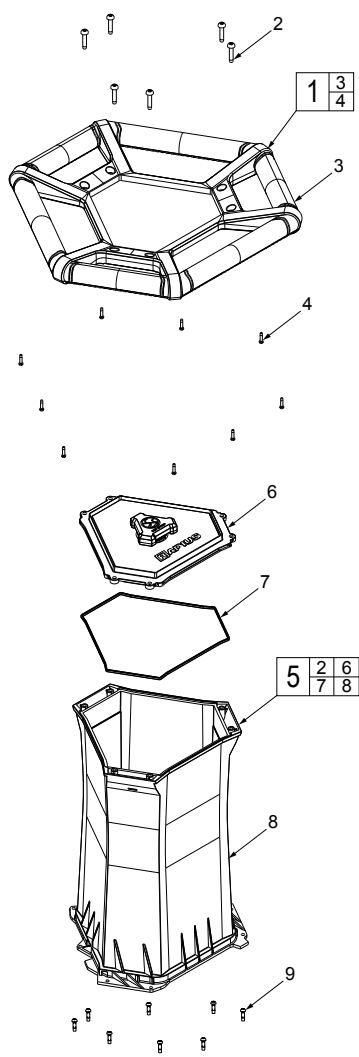

FIG.	PART NO.	DESCRIPTION OF PART	NO. REQ.
1	14-34-0005	Top Handle Assembly	(1)
2	06-82-2250	M5 T25 Torx Screw	(6)
3	-----	Top Handle	(1)
4	06-82-0190	M3 x 14 Screw	(9)
5	44-06-0135	Lens Assembly	(1)
6	-----	Top Lens	(1)
7	43-40-0045	Lens Cover Seal	(1)
8	-----	Lens	(1)
9	06-82-0195	M4 x 12 Screw	(10)

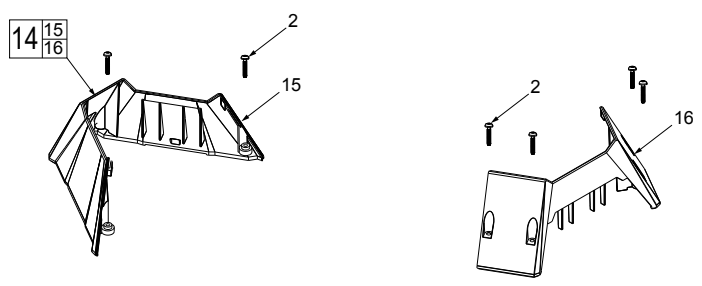

FIG.	PART NO.	DESCRIPTION OF PART	NO. REQ.
2	06-82-2250	M5 T25 Torx Screw	(6)
14	43-76-0045	Main Body Cover Kit	(1)
15	-----	Back Housing	(1)
16	-----	Front Housing	(1)

NOTE:
Coin Cell Cover Kit Design A is screw dependent, while Coin Cell Cover Kit Design B is not. Both designs are interchangeable and it is the customer's preference which to order.

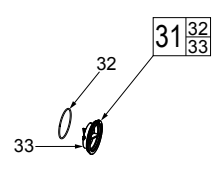

FIG.	PART NO.	DESCRIPTION OF PART	NO. REQ.
31	31-15-0475	Coin Cell Cover Kit (Design A)	(1)
	31-15-0009	Coin Cell Cover Kit (Design B)	(1)
32	-----	O-Ring	(1)
33	-----	Coin Cell Cover	(1)

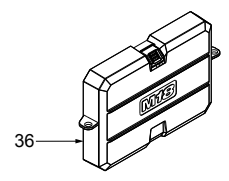

FIG.	PART NO.	DESCRIPTION OF PART	NO. REQ.
36	31-21-0125	Battery Door Assembly	(1)

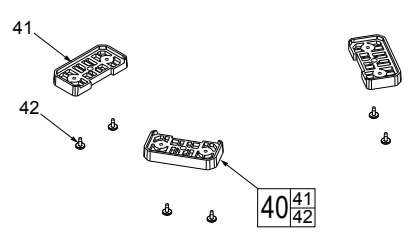

FIG.	PART NO.	DESCRIPTION OF PART	NO. REQ.
40	14-74-0015	Rubber Boot Kit	(1)
41	-----	Rubber Boot	(3)
42	-----	M4 x 12 Screw w/ Washer	(6)