



# SERVICE PARTS LIST

**BULLETIN NO.**  
**54-38-2681**

<b>SPECIFY CATALOG NO. AND SERIAL NO. WHEN ORDERING PARTS</b>		REVISED BULLETIN 54-38-2680	DATE Aug. 2014
<b>CORDLESS 18 VOLT 4-1/2" CUT-OFF/GRINDER</b>			
<b>CATALOG NO.</b>	<b>2680-20</b>	<b>STARTING SERIAL NO.</b>	<b>B96B</b>
<b>WIRING INSTRUCTION SEE PAGE 3</b>			

**EXAMPLE:**  
Component Parts (Small #) Are Included  
When Ordering The Assembly (Large #).

★ = Part number change from  
previous service parts list.

**FIG. LUBRICATION:**  
(Use Type 'Y' grease, No. 49-08-5270)

10 Apply a thin coat of grease to the  
Spindle Hub O-Ring.

13,38 Apply grease to all teeth of the  
Pinion and Gear.

27 Place 1/8 oz. grease in Gearcase  
cavity.

32,33 Apply a thin coat of grease between  
Spindle Lock Shaft and O-Ring.

Functionally check the Spindle Lock  
mechanism. Spindle Lock must  
return briskly when released  
from engagement in  
Gear (13).

FIG.	PART NO.	DESCRIPTION OF PART	NO. REQ.
1	05-88-1210	M4 x 14 T-20 Screw	(4)
2	05-88-1200	M4 x 16 T-20 Screw	(9)
3	06-82-7236	4-20 x 5/8" Pan Hd. Plast. T-10 Screw	(1)
4	05-90-0225	Split Washer	(4)
5	14-34-0900	Handle Kit	(1)
6	-----	Right Handle Halve	(1)
7	-----	Left Handle Halve	(1)
8	-----	Spindle Shaft	(1)
9	-----	Spindle Hub	(1)
10	34-40-0560	O-Ring	(1)
11	-----	Ball Bearing	(1)
12	34-80-2275	Internal Snap Ring	(1)
13	-----	Gear	(1)
14	40-50-1090	Spring	(1)
15	22-09-1350	Electronics Module Assembly	(1)
★ 17	32-05-0120	Spindle Shaft/Gear Assembly	(1)
18	23-66-2875	Switch Assembly	(1)
19	-----	Brush Card	(1)
20	31-92-0530	Paddle Trigger Assembly	(1)
21	-----	Paddle Trigger	(1)
22	42-42-0620	Lock-Off Lever	(1)
23	40-50-1480	Spring	(1)
24	06-65-0450	Roll Pin	(1)
25	14-30-0850	Gearcase Kit	(1)
26	28-14-2450	Gearcase Assembly	(1)
27	-----	Gearcase	(1)
28	-----	Needle Bearing	(1)
29	42-42-1100	Spindle Lock Button	(1)
30	40-50-1330	Spring	(1)
31	42-42-0580	Spindle Lock Tube	(1)
32	44-60-1690	Spindle Lock Pin	(1)
33	34-40-0450	O-Ring	(1)
★ 34	16-01-0060	Armature Assembly	(1)
36	-----	Bearing Retainer	(1)
37	-----	Ball Bearing	(1)
38	-----	Pinion	(1)
39	45-36-2040	Armature Spacer	(3)
40	02-04-1875	Ball Bearing	(1)
41	18-01-3025	Service Field	(1)
42	43-34-0036	Disk Flange	(1)
43	44-40-0035	Flange Nut	(1)
44	12-20-2490	Service Nameplate Kit	(1)
60	43-54-1070	4.5" T27 Guard Assembly	(1)
61	43-54-1090	4.5" T1 Guard Assembly	(1)
72	05-88-0928	M3 x 5mm Pan Hd. T10 Screw	(2)
73	45-88-1980	Spring Washer	(2)
74	-----	Leadwire Assembly - Red	(1)
75	-----	Leadwire Assembly - Black	(1)
76	14-46-2396	Leadwire/Screw/Washer Kit	(1)
77	14-46-2014	Brush Card Assembly	(1)
42-62-0105	-----	Side Handle (Not Shown)	(1)
49-96-7215	-----	Spanner Wrench (Not Shown)	(1)

**#77 two styles of  
Brush Card Assemblies  
See Page Two**

**FIG. NOTES:**  
28 Assemble Needle Bearing with  
vendor I.D. facing the Gear.  
37 Assemble Ball Bearing with seal  
towards Pinion and shield towards  
Armature.

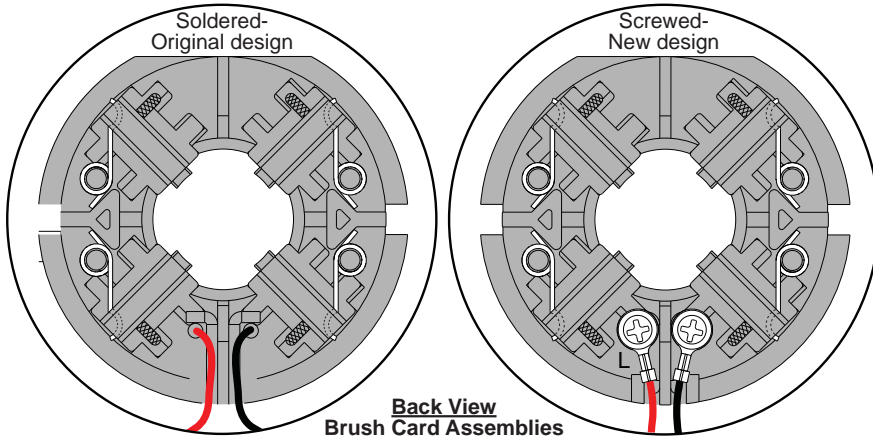

**NOTE:**  
There are two Brush Card Assembly designs.

On the original brush card design the red and black wires that go to the switch are soldered on the brush card.

On the new brush card design the red and black wires that go to the switch are secured to the brush card with spring washers and screws.

The new brush card design is **directly interchangeable** in tools that have the old brush card design.

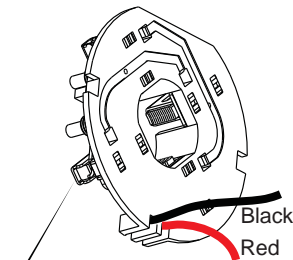

**Brush Card Assy.**

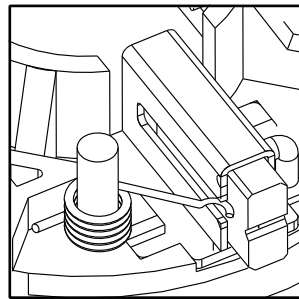

**NOTE:**  
As an aid to prevent damage to the armature commutator or the brushes when removing and installing the armature assembly, it is recommended to pull the carbon brushes partially back into the brush tube. The carbon brushes will be held in place with the brush spring moving from the rear of the brush to the side of the brush.

In the unlikely event that the spring pops off follow the instructions below.

- Brush Shunt (4 places)
- Right Brush Spring (2x)
- Carbon Brush (4x)
- Left Brush Spring (2x)

Be sure carbon brush is in brush tube with brush shunt moving freely in side groove of tube.

Place brush spring over post with short leg positioned downward as shown. Be sure spring is completely down with short leg trapped against 'Y' shaped wall on brush card.

While holding spring in place, bring the long leg of spring over the brush tube and through rear opening of tube. Position rounded hook of spring in groove on back of carbon brush. Be sure to check for free movement between carbon brush, brush shunt and brush spring.

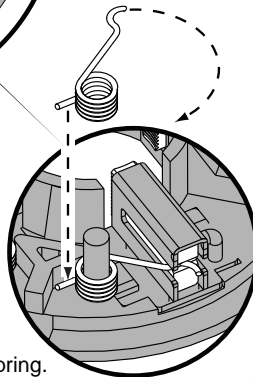

Wrong



Correct

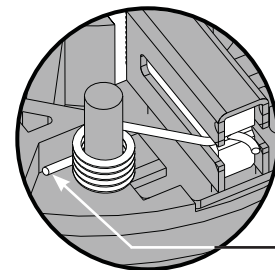

Short leg of spring to the bottom

AS AN AID TO REASSEMBLY, TAKE NOTICE OF WIRE ROUTING AND POSITION IN WIRE GUIDES AND TRAPS WHILE DISMANTLING TOOL.

**PC BOARD**  
(Component of the Electronics Module Assembly)

⑧ BLACK  
(From Terminal Block to PCB)

**SWITCH ASSEMBLY**

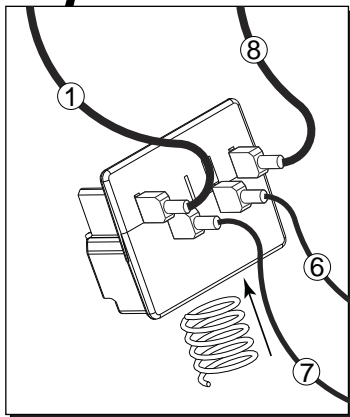
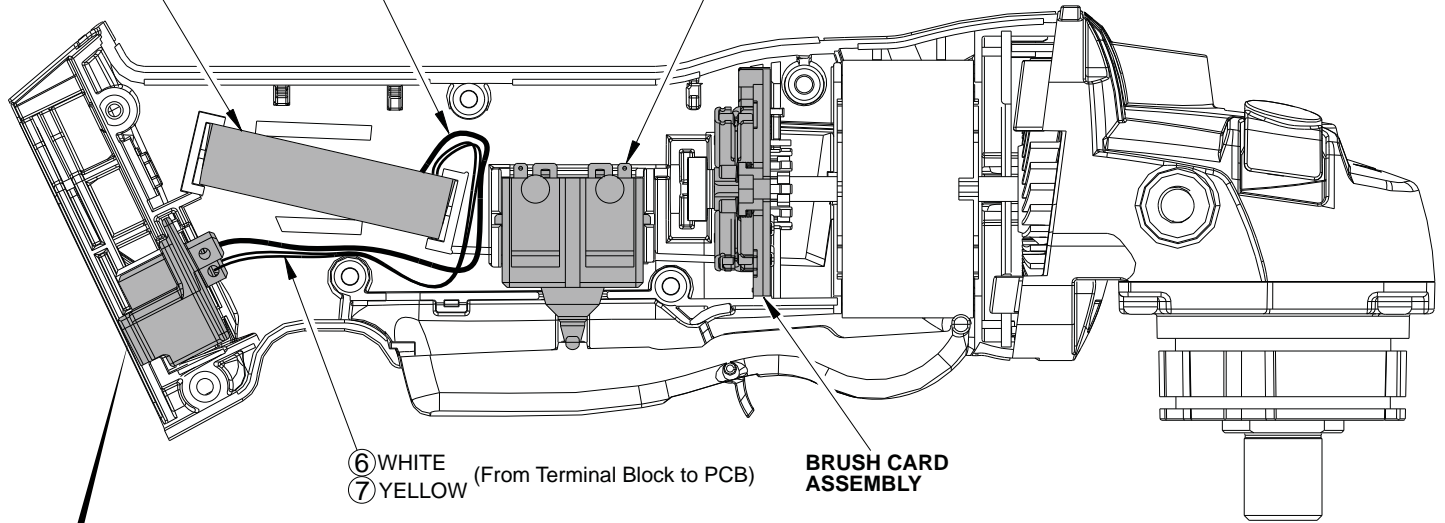

BLACK ②  
(From Switch to PCB)

④ BLACK  
(From Brush Card to Switch)

RED ③ (From Switch to PCB)

⑤ RED  
(From Brush Card to Switch)

**CONNECTOR BLOCK**  
(Component of the Electronics Module Assembly)

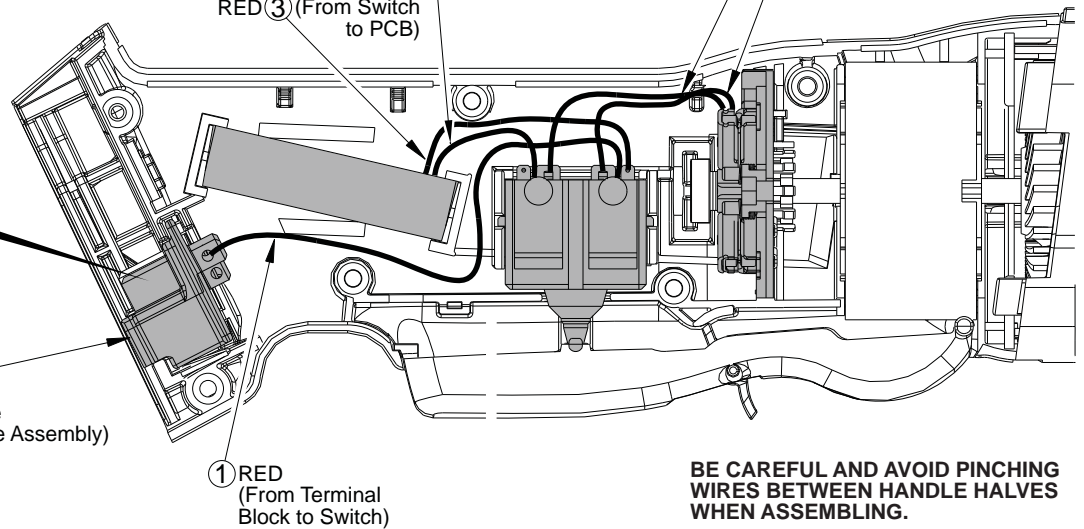

**BE CAREFUL AND AVOID PINCHING WIRES BETWEEN HANDLE HALVES WHEN ASSEMBLING.**

**WIRING SPECIFICATIONS**

Wire No.	Wire Color	Origin or Gauge	Length	Terminals, Connectors and 1 or 2 End Wire Preparation
1	Red	14	-----	Component of the Electronics Module Assembly.
2	Black	14	-----	Component of the Electronics Module Assembly.
3	Red	18	-----	Component of the Electronics Module Assembly.
4	Black	15	-----	Component of the Brush Card Assembly.
5	Red	15	-----	Component of the Brush Card Assembly.
6	White	24	-----	Component of the Electronics Module Assembly.
7	Yellow	24	-----	Component of the Electronics Module Assembly.
8	Black	14	-----	Component of the Electronics Module Assembly.

