



SERVICE PARTS LIST

BULLETIN NO.
54-06-2740

SPECIFY CATALOG NO. AND SERIAL NO. WHEN ORDERING PARTS		REVISED BULLETIN	DATE
M18™ FUEL™ Drill-Driver			Nov. 2015
CATALOG NO. 2703-20	STARTING SERIAL NO. G72A	WIRING INSTRUCTION SEE PAGE 2	

EXAMPLE:

00	0
----	---

 Component Parts (Small #) Are Included When Ordering The Assembly (Large #).

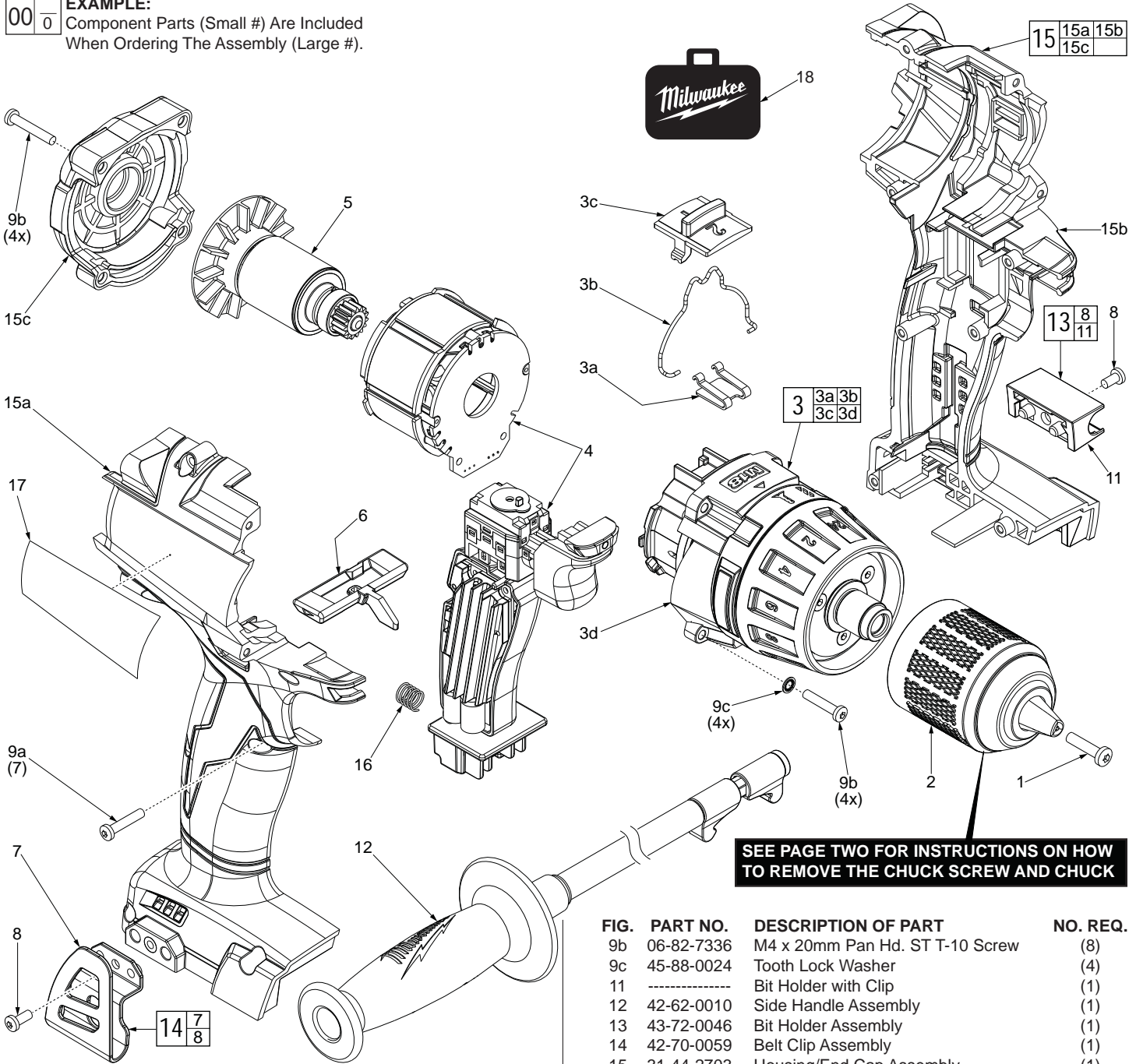

SEE PAGE TWO FOR INSTRUCTIONS ON HOW TO REMOVE THE CHUCK SCREW AND CHUCK

FIG.	PART NO.	DESCRIPTION OF PART	NO. REQ.
1	05-88-0019	M8.0 x 1 LH T-40 Chuck Screw	(1)
2	42-66-0090	1/2" Keyless Chuck	(1)
3	14-29-0027	Gearbox Assembly	(1)
3a	40-50-0021	Detent Spring	(1)
3b	45-24-0012	Speed Change Lever	(1)
3c	44-10-0014	Speed Selector Slide	(1)
3d	-----	Gearbox	(1)
4	14-20-0032	Electronics Assembly Consists of: On-Off Switch, PCBA, Stator, LED Assembly, Battery Connector Block	(1)
5	16-07-0041	Rotor Assembly	(1)
6	42-42-0052	Forward/Reverse Shuttle	(1)
7	-----	Belt Clip	(1)
8	06-82-5275	6-32 x 5/16" Pan Hd. Taprite T-15 Screw	(2)
9a	06-82-6350	M3 x 16mm Pan Hd. ST T-10 Screw	(7)

FIG.	PART NO.	DESCRIPTION OF PART	NO. REQ.
9b	06-82-7336	M4 x 20mm Pan Hd. ST T-10 Screw	(8)
9c	45-88-0024	Tooth Lock Washer	(4)
11	-----	Bit Holder with Clip	(1)
12	42-62-0010	Side Handle Assembly	(1)
13	43-72-0046	Bit Holder Assembly	(1)
14	42-70-0059	Belt Clip Assembly	(1)
15	31-44-2703	Housing/End Cap Assembly	(1)
15a	-----	Right Housing Halve	(1)
15b	-----	Left Housing Halve	(1)
15c	-----	End Cap	(1)
16	40-50-1090	Compression Spring	(1)
17	12-20-0048	Service Nameplate	(1)
18	42-55-2703	Blow Molded Carrying Case	(1)

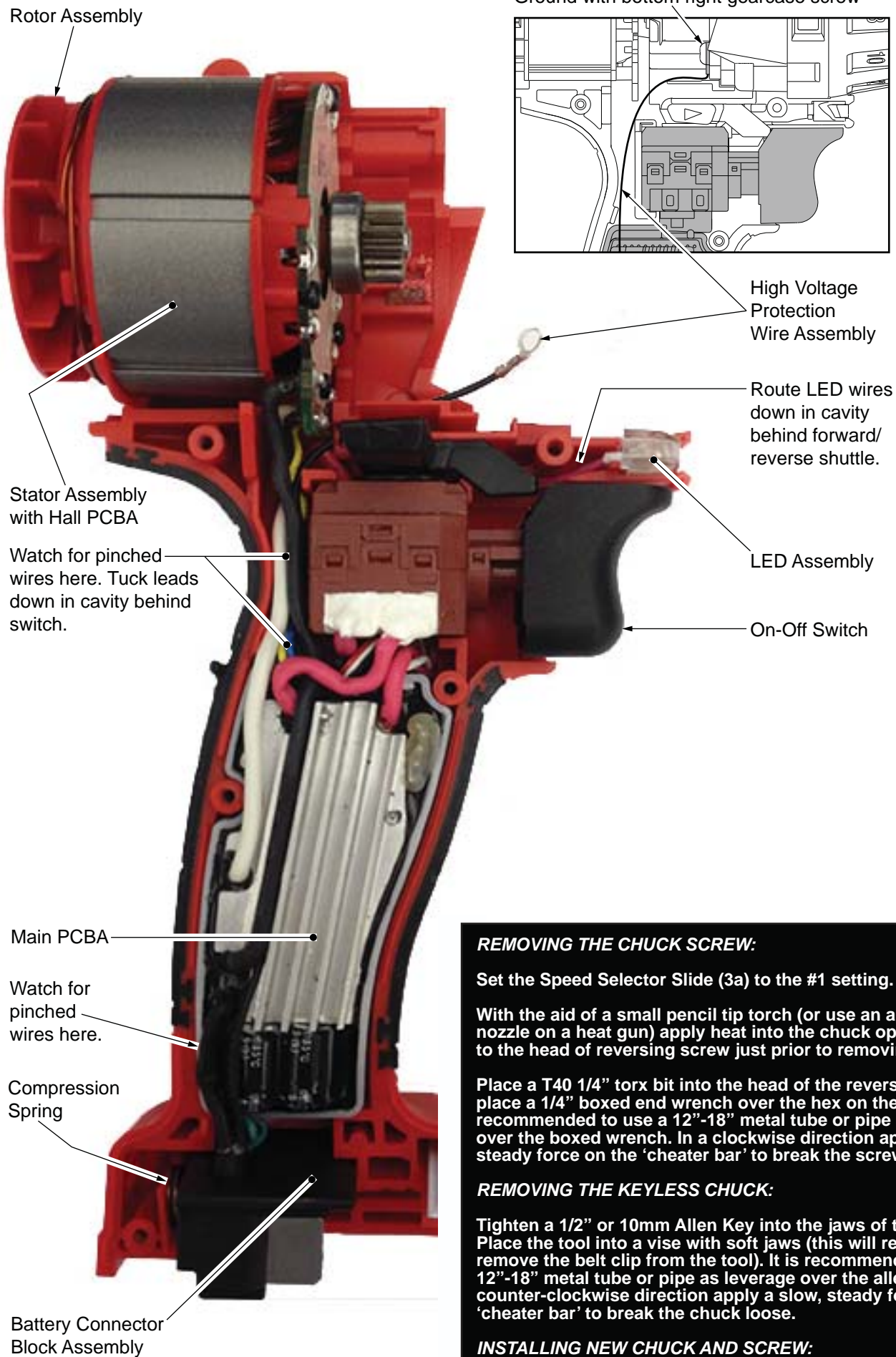

REMOVING THE CHUCK SCREW:

Set the Speed Selector Slide (3a) to the #1 setting.

With the aid of a small pencil tip torch (or use an air reduction nozzle on a heat gun) apply heat into the chuck opening, directly to the head of reversing screw just prior to removing the screw.

Place a T40 1/4" torx bit into the head of the reversing screw and place a 1/4" boxed end wrench over the hex on the T40 bit. It is recommended to use a 12"-18" metal tube or pipe as leverage over the boxed wrench. In a clockwise direction apply a slow, steady force on the 'cheater bar' to break the screw loose.

REMOVING THE KEYLESS CHUCK:

Tighten a 1/2" or 10mm Allen Key into the jaws of the chuck. Place the tool into a vise with soft jaws (this will require that you remove the belt clip from the tool). It is recommended to use a 12"-18" metal tube or pipe as leverage over the allen key. In a counter-clockwise direction apply a slow, steady force on the 'cheater bar' to break the chuck loose.

INSTALLING NEW CHUCK AND SCREW:

Torque Chuck to 1095 kg/cm (950.418 in/lbs or 28.93 ft/lbs)
 Torque Screw to 461 kg/cm (400.130 in/lbs or 33.34 ft/lbs)