

PARTS LIST FOR
5004 SERIES
PORTABLE
ELECTRIC DRIVEN/BELT DRIVE
COLD WATER PRESSURE WASHER
(AFTER SERIAL #10235166)

Motor Horsepower:	15 HP
Pump Oil Grade:	Pump Oil #AW-4085-0016
Pump Oil Capacity:	31.0 oz.
Nozzle Size:	3.5

This Parts Listing has been compiled for your benefit. You can be assured your new Cold Water Pressure Washer was constructed and designed with quality and performance in mind using over 25 years experience in the pressure washer business. Each component has been rigorously tested to insure the highest level of acceptance.

The contents of this Parts Listing are based on the latest product information available at the time of publication. The manufacturer reserves the right to make changes in price, color, materials, equipment, specifications or models at any time without notice.

WARNING

THIS IS A PROFESSIONAL HIGH PRESSURE, COLD WATER PRESSURE WASHER. CAUTION SHOULD BE OBSERVED WHEN USING OR REPAIRING THIS UNIT! READ AND FOLLOW THE SAFETY WARNINGS LISTED BELOW BEFORE ATTEMPTING ANY REPAIRS ON THIS PRESSURE WASHER!

SAFETY WARNINGS

1. NEVER alter or modify the equipment. Be sure any accessory items and system components being used will withstand the pressure developed. Use only genuine manufactured parts for repair of your pressure washer. Failure to do so can cause hazardous operating conditions and will VOID warranty.
2. NEVER make adjustments on machinery while the unit is connected to the power source. Turning over the machinery by hand during adjustment or cleaning might start the machinery, causing serious injury to the operator.
3. Know how to stop and bleed pressures quickly. Be thoroughly familiar with controls.
4. Before servicing the unit, turn unit off, relieve the water pressure and allow the unit to cool down. Do not make repairs while the unit is running. Service in a clean, dry, flat area.
5. After testing the machine, DO NOT leave the pressurized unit unattended. Shut off the unit and release trapped pressure before leaving.

Table of Contents

SPECIFICATIONS	3
NOTES	4
NOTES	5
FRAME ASSEMBLY FOR 5004 (AFTER SERIAL #10235166)	6
PUMP ASSEMBLY (3-0261)	8
UNLOADER ASSEMBLY (8-0522)	10
GUN ASSEMBLY (16-0343)	12
CONTROL BOX ASSEMBLY (230 VOLT) (AFTER SERIAL #10154637)	14
WIRING SCHEMATIC (230 VOLT)	16
WIRING DIAGRAM (230 VOLT)	17
CONTROL BOX ASSEMBLY (CX-0057 OPTION) (460 VOLT)	18
WIRING SCHEMATIC (460 VOLT)	20
WIRING DIAGRAM (460 VOLT)	21

SPECIFICATIONS

Operating Pressure (PSI/Bar):	5000/344.7
High Pressure Nozzle:	3.5
Water Volume (GPM/lpm):	4.0/15.1
Motor:protection,	Totally enclosed fan cooled, circuit breaker thermal overload 35ft. power supply cord.
Horsepower	15.0
Voltage	230
Phase	Three
Amps	40
Pump:	Belt Driven, Oil Bath, Triplex Piston
Oil Type	Pump Oil #AW-4085-0016
Oil Capacity (oz./liters)	31 .0/.92
Plungers	Ceramic
Manifold	Forged Brass
Valves	Stainless Steel
Unloader	Preset
Heat Dump Valve	Relieves heated water during unloader bypass stage
Unit Net Weight w/Marathon (lbs/Kg)	379/1 72
Unit Shipping Weight w/Marathon (lbs/Kg)	520/236
Unit Net Weight w/Baldor (lbs/Kg)	424/1 92
Unit Shipping Weight w/Baldor (lbs/Kg)	565/256
Unit Net Dimension (in/cm)	45.5Lx32.5Wx30H/ 115.5Lx82.5Wx76.5H
Unit Shipping Dimension (in/cm)	48.5Lx30.5Wx35.5H/ 123Lx77.5Wx90H

NOTES

SERIAL BREAK NUMBER:

#397220

#10005894

#10154637

#10235166

SERIAL BREAK EXPLANATION:

CHANGED FROM A 851-0308 BURST DISK TO 22-0319 SAFETY RELIEF VALVE (NO DRAWINGS).

UNLOADER CHANGED FROM 8-0480 TO 8-0522 (NO DRAWINGS BEFORE SERIAL #).

CHANGED CORD STRAIN RELIEF ON CONTROL BOX DWG. FROM 32-0040 TO 9-0048.

CHANGED PUMP 3-0169 TO 3-0261. CHANGED SHEAVE 10-0106 TO 10-0108.

NOTES

FRAME ASSEMBLY FOR 5004 (AFTER SERIAL #10235166)

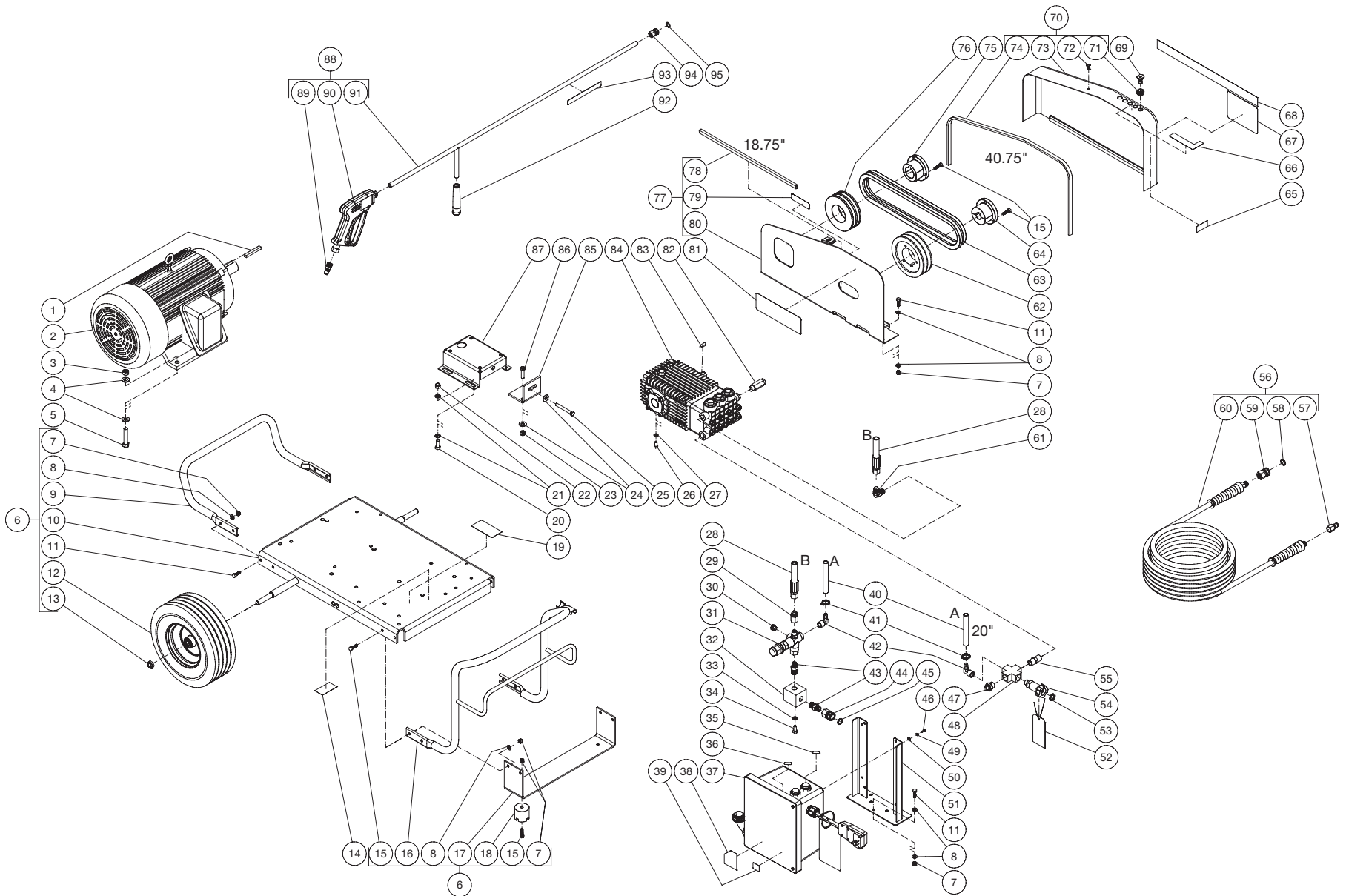

DC-5004-W0E3G 101920 JRC

FRAME ASSEMBLY							
ITEM	DESCRIPTION	PART #	QTY	ITEM	DESCRIPTION	PART #	QTY
1	KEY	43-0165	1	51	BRACKET	13-0227A18	1
2	MOTOR	2-0018	1	52	TAG - WATER SUPPLY INLET (E)	N/A	1
3	NUT	30-0163	4	53	GARDEN HOSE GASKET	26-0001	1
4	WASHER	28-0006	8	54	FILTER	19-0206	1
5	BOLT	27-0221	4	55	NIPPLE	23-0012	1
6	BASEPLATE	851-0333	1	56	HOSE ASSEMBLY	851-0317	1
7	LOCKNUT	30-0157	17	57	QUICK CONNECT	17-0006	1
8	WASHER	28-0003	22	58	O-RING	25-0123	1
9	REAR HANDLE	7-0105A18	1	59	QC SOCKET	17-0041	1
10	BASEPLATE	5-0334A18	1	60	HOSE	N/A	1
11	BOLT	27-0067	11	61	3/8" ELBOW	24-0092	1
12	WHEEL	14-0150	2	62	SHEAVE	10-0107	1
13	LOCKNUT	30-0117	2	63	BELT	11-0047	2
14	DECAL	-	1	64	BUSHING	9-0073	1
15	BOLT	27-0068	12	65	DECAL - MADE IN USA	34-3553	1
16	FRONT HANDLE	7-0102A18	1	66	DECAL - NOZZLE (SEE 71-1045)	N/A	1
17	BRACKET	13-0015A18	1	67	DECAL - LOGO SEE DX OPTION	N/A	1
18	ISOLATOR	14-0008	2	68	DECAL - STRIPE SEE DX OPTION	N/A	1
19	DECAL- SILVER STICKER	N/A	1	69	NOZZLE	18-0392	1
20	BOLT	27-0166	4	-	NOZZLE	18-0393	1
21	WASHER	28-0030	8	-	NOZZLE	18-0395	1
22	LOCKNUT	30-0161	4	-	NOZZLE	18-0396	1
23	LOCKNUT	30-0159	2	70	BELTGUARD COVER ASSEMBLY	850-0242	1
24	WASHER	28-0023	3	71	GROMMET	33-0001	5
25	BOLT	27-0576	1	72	FASTENER	33-0197	1
26	BOLT	27-8042	4	73	BELTGUARD COVER	N/A	1
27	LOCKWASHER	29-0054	4	74	EDGING *(FOUR FEET REQUIRED)	33-0020	1
28	HIGH PRESSURE HOSE	15-0254	1	75	BUSHING	9-0072	1
29	ADAPTER	24-0150	1	76	SHEAVE	10-0108	1
30	PLUG	39-0017	1	77	BELTGUARD BACK ASSEMBLY	851-0335	1
31	UNLOADER	8-0522	1	78	EDGING *(TWO FEET REQUIRED)	33-0020	1
32	MANIFOLD BLOCK	51-0012	1	79	DECAL - BELTGUARD IN PLACE (SEE 71-1045)	N/A	1
33	LOCKWASHER	29-0008	2	80	BELT GUARD BACK	N/A	1
34	BOLT	27-0116	2	81	DECAL-WARNING/CAUTION/OPERATION (SEE 71-1045)	N/A	1
35	DECAL - RUN (SEE 71-1045)	N/A	1	82	VALVE	22-0319	1
36	DECAL - STOP (SEE 71-1045)	N/A	1	83	KEY	43-0028	1
37	STARTER	N/A	1	84	PUMP	3-0261	1
38	DECAL - DO NOT SPRAY (SEE 71-1045)	N/A	1	85	BRACKET	13-0003A18	1
39	DECAL - WARNING REMOVAL OF COVER (SEE 71-1045)	N/A	1	86	BOLT	27-0119	2
40	HOSE *(TWO FEET REQUIRED)	15-0007	2	87	PUMP BRACKET	5-0101A18	1
41	HOSE CLAMP	42-0011	2	88	GUN ASSEMBLY	851-0309	1
42	HOSE BARB	23-0418	2	89	QUICK CONNECT	17-0005	1
43	ADAPTER	24-0024	2	90	GUN	16-0343	1
44	QC SOCKET	17-0041	1	91	WAND	16-0342A18	1
45	O-RING	25-0123	1	92	GRIP	7-0002	1
46	SCREW (W/ CW-A-0001 ELECTRIC BOX)	-	4	93	DECAL - RISK OF INJECTION (SEE 71-1045)	N/A	1
47	RELIEF VALVE	22-0005	1	94	QUICK CONNECT	17-0036	1
48	CROSS	23-0071	1	95	O-RING	25-0122	1
49	STAR WASHER	28-1009	4	-	DECAL SET - 4000/5000 ELEC	71-1045	1
50	WASHER	28-0001	4				

*MUST ORDER IN ONE FOOT LENGTHS

PUMP ASSEMBLY (3-0261)

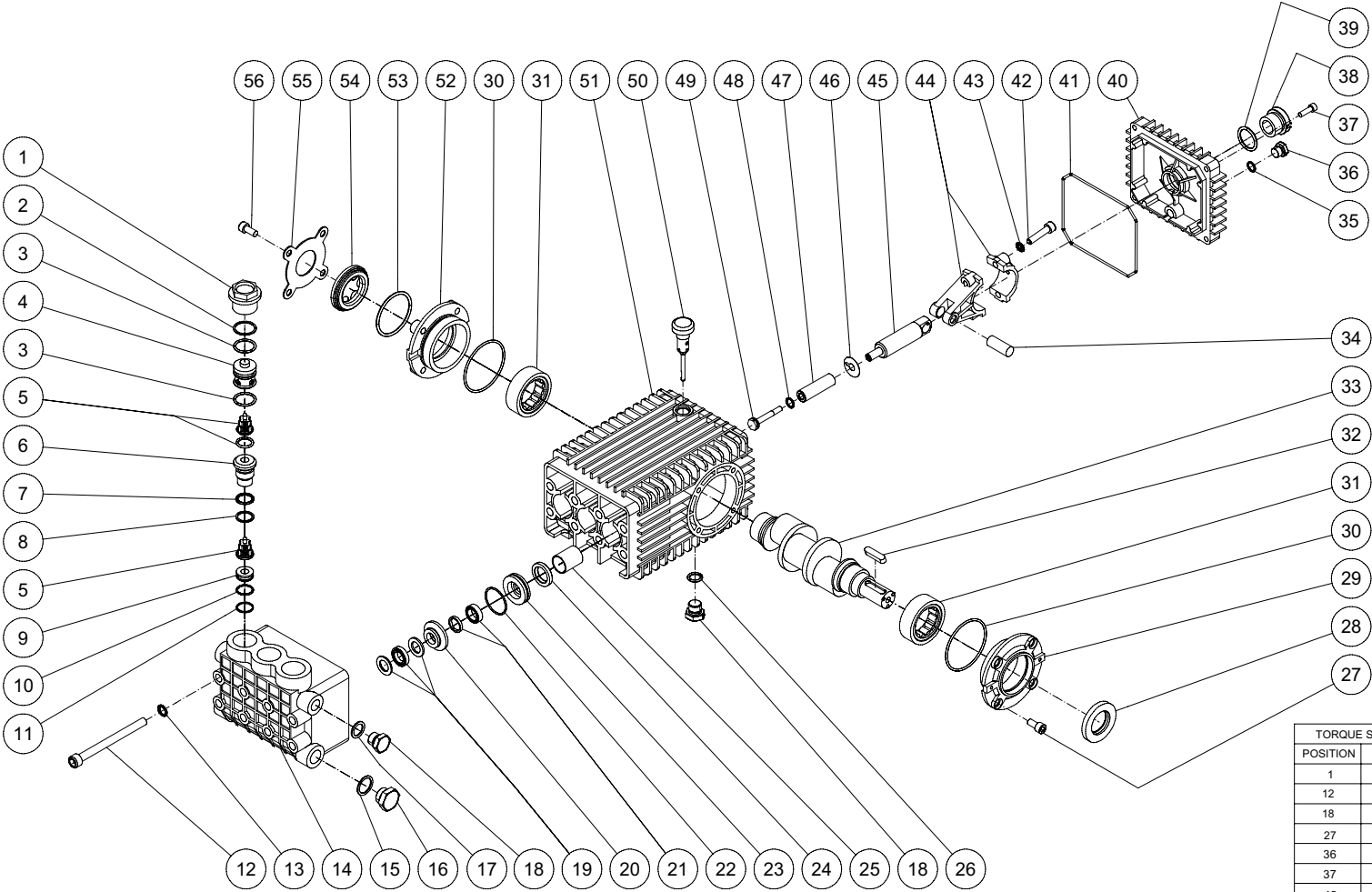

TORQUE SPECS.	
POSITION	FT-LBS
1	95.9
12	33.2
18	29.5
27	14.8
36	14.8
37	7.4
42	14.8
49**	14.8
56	14.8

** USE LOC-TITE 542

PUMP ASSEMBLY

ITEM	DESCRIPTION	Mi-T-M #	QTY	ITEM	DESCRIPTION	Mi-T-M #	QTY
1	VALVE PLUG	46-1203	3	29	CRANKCASE COVER OPEN	46-1217	1
2	RING	25-0592	3	30	O-RING	25-0590	2
3	O-RING	25-0139	6	31	BEARING	48-0085	2
4	CAP	46-1206	3	32	KEY	46-0602	1
5	VALVE ASSEMBLY (SEE KIT 70-0431)	SEE KIT	6	33	CRANKSHAFT	46-1210	1
6	GUIDE	46-1205	3	34	CONNECTING ROD PIN	43-0118	3
7	O-RING	25-0160	3	35	O-RING	25-0014	1
8	BACKUP RING	25-0430	3	36	PLUG	39-0017	1
9	SPACER	46-1204	3	37	BOLT	27-8812	4
10	O-RING	25-0130	3	38	SIGHT GLASS	46-1163	1
11	BACKUP RING	25-0591	3	39	O-RING	25-0059	1
12	BOLT	27-8073	8	40	CRANKCASE COVER	46-1212	1
13	LOCKWASHER	29-0155	8	41	O-RING	25-0339	1
14	MANIFOLD	N/A	1	42	BOLT	27-8435	6
15	WASHER	28-1038	1	43	LOCKWASHER	29-1014	1
16	PLUG	39-0019	1	44	CONNECTING ROD	46-1211	3
17	WASHER	28-1002	1	45	PLUNGER ROD	46-1213	3
18	PLUG	39-0018	2	46	SLINGER WASHER	46-1214	3
19	HIGH PRESSURE SEAL ASSEMBLY (SEE KIT 70-0433 & 70-0434)	SEE KIT	3	47	PLUNGER	46-1215	3
20	HIGH PRESSURE INTERMEDIATE SEAL RETAINER (SEE KIT 70-0434)	SEE KIT	3	48	O-RING	25-0310	3
21	LOW PRESSURE SEAL (SEE KIT 70-0433 & 70-0434)	SEE KIT	3	49	BOLT / PISTON	46-1216	3
22	O-RING (SEE KIT 70-0434)	25-0015	3	50	OIL DIP STICK	46-0144	1
23	LOW PRESSURE SEAL RETAINER (SEE KIT 70-0434)	SEE KIT	3	51	CRANKCASE	46-1209	1
24	OIT SEAL (SEE KIT 70-0432)	26-0047	3	52	CRANKCASE COVER	46-1208	1
25	BUSHING	9-0029	3	53	O-RING	25-0060	1
26	O-RING	25-0052	1	54	OIL LEVEL INDICATOR	46-0574	1
27	BOLT	27-8431	4	55	SIGHTGLASS COVER	46-1207	1
28	OIL SEAL	26-0049	1	56	BOLT	27-8433	4

REPLACEMENT KITS

Mi-T-M KIT#	DESCRIPTION	ITEMS	# OF ASSEMBLIES	# OF CYLINDERS
70-0432	OIL SEAL KIT	24	3	3
70-0431	VALVE KIT	5	6	3
70-0433	LOW/HIGH PRESSURE SEALS	19, 21	3	3
70-0434	PACKING KIT	19-23	1	1

UNLOADER ASSEMBLY (8-0522)

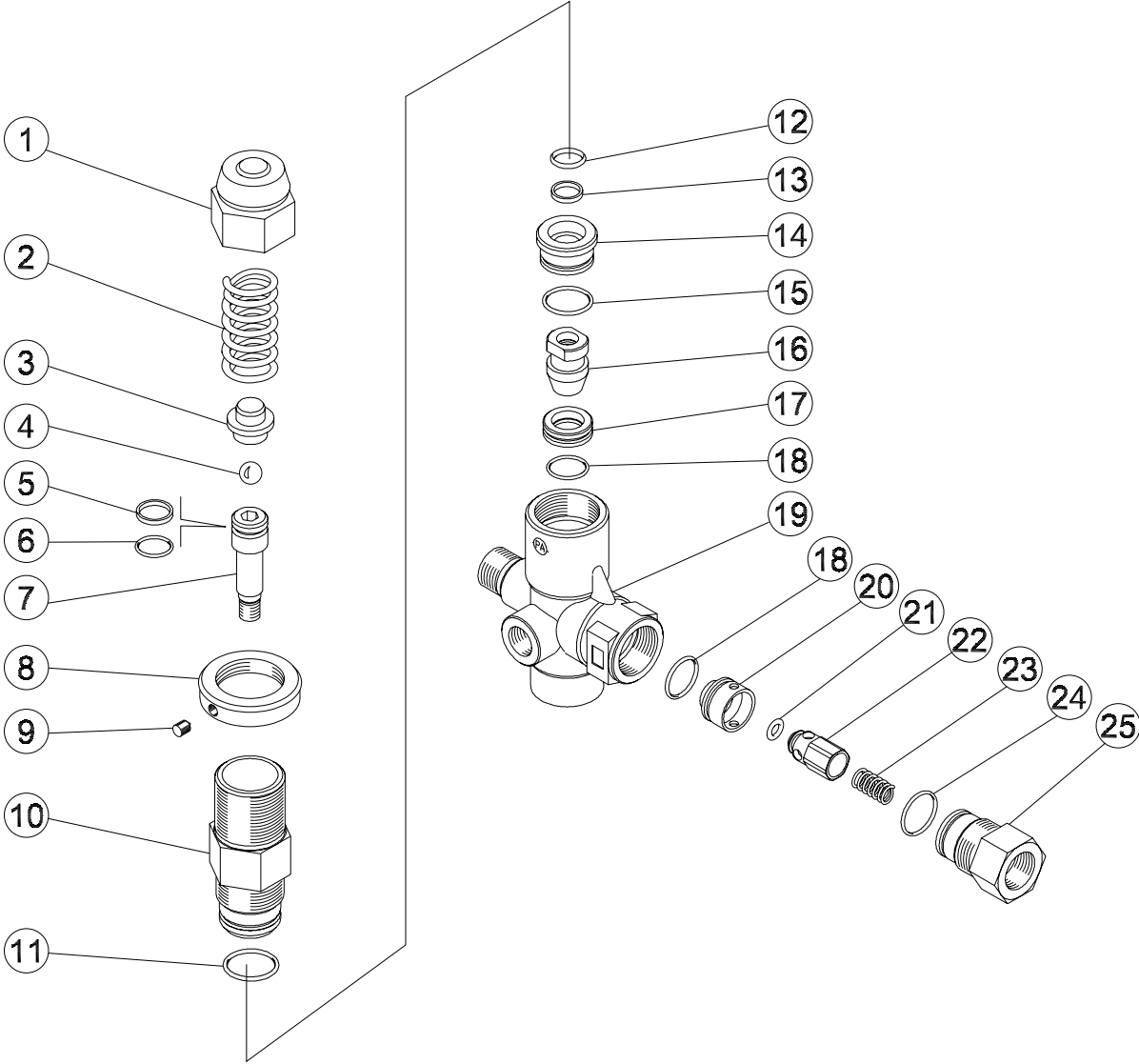

8-0522-120501-RD

UNLOADER ASSEMBLY (8-0522)

REF. #	DESCRIPTION	PART #	QTY.	REF. #	DESCRIPTION	PART #	QTY.
1	Brass Cap	8-0534	1	15	O-ring	25-0368	1
2	Spring	49-0149	1	16	Shutter	8-0540	1
3	Spring Guide	8-0535	1	17	Seat	8-0541	1
4	Ball	8-0318	1	18	O-ring	25-0220	2
5	Back-up Ring (See 70-0342)	N/A Sep.	1	19	Valve Body	8-0542	1
6	O-ring (See 70-0342)	N/A Sep.	1	20	Check Valve Seat	8-0543	1
7	Piston	8-0536	1	21	O-ring	25-0369	1
8	Lock Ring	8-0537	1	22	Check Valve	8-0486	1
9	Set Screw	8-0408	1	23	Spring	49-0150	1
10	Piston Housing	8-0538	1	24	O-ring	25-0325	1
11	O-ring	25-0189	1	25	Nipple	8-0485	1
12	Back-up Ring (See 70-0343)	N/A Sep.	1		Upper Seal Kit (Inc. 5, 6)	70-0342	1
13	O-ring (See 70-0343)	N/A Sep.	1		Lower Seal Kit (Inc. 12, 13)	70-0343	1
14	Spacer	8-0539	1				

GUN ASSEMBLY (16-0343)

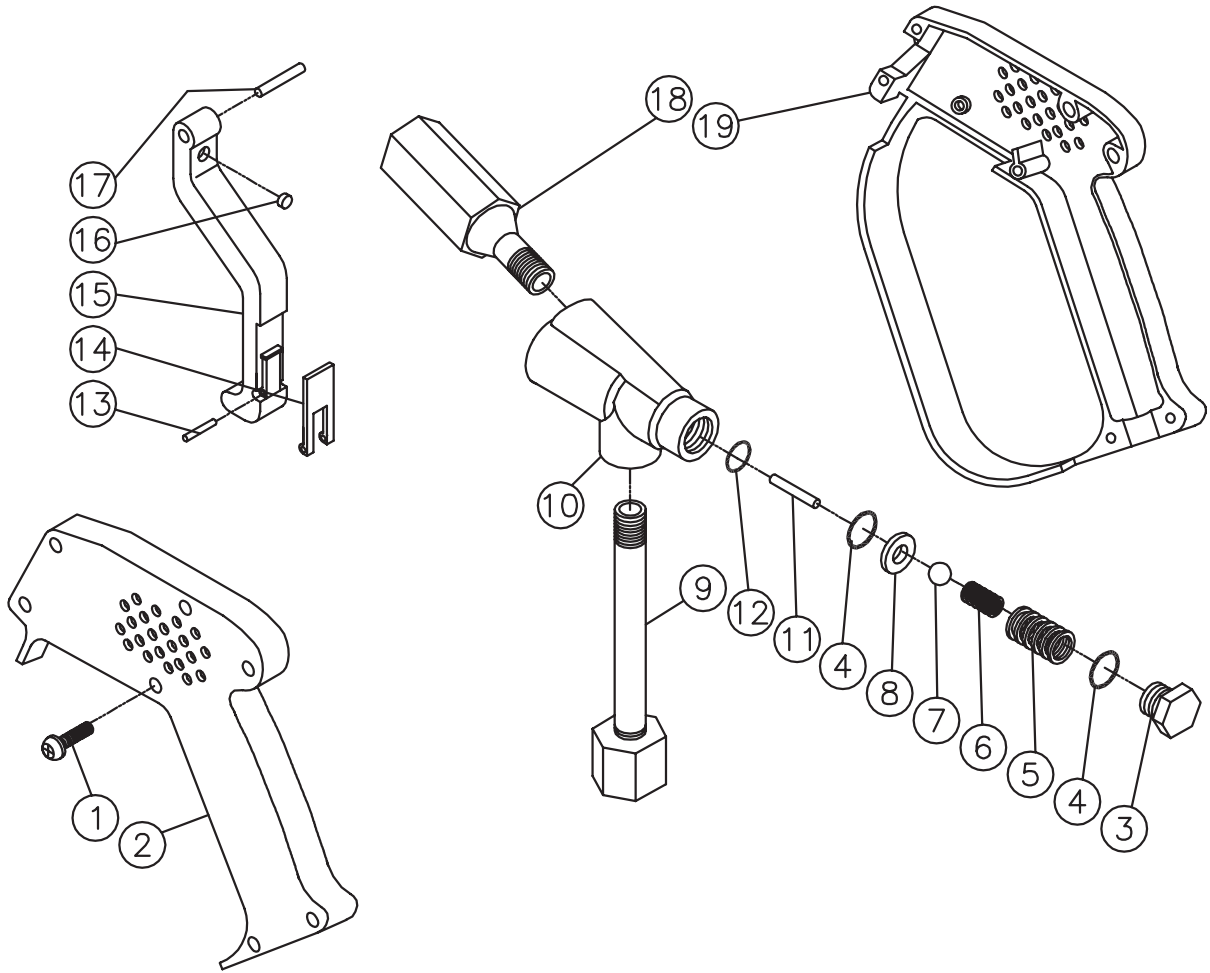

16-0343 101711 AJH

GUN ASSEMBLY (16-0343)

REF. #	DESCRIPTION	PART #	QTY.	REF. #	DESCRIPTION	PART #	QTY.
1	Screw	27-8851	7	11	O-ring (See 70-0213)	N/A Sep.	1
2	Housing- Left Side	16-0344	1	12	Control Pin (See 70-0213)	N/A Sep.	1
3	Cap	23-0336	1	13	Lock Pin	43-0025	1
4	O-ring (See 70-0213)	N/A Sep.	2	14	Safety Lock	16-0347	1
5	Spring (See 70-0213)	N/A Sep.	1	15	Trigger	16-0348	1
6	Valve Spring (See 70-0213)	N/A Sep.	1	16	Cam Trigger (See 70-0213)	N/A Sep.	1
7	Valve Ball (See 70-0213)	N/A Sep.	1	17	Pin	43-0024	1
8	Valve Seat (See 70-0213)	N/A Sep.	1	18	Discharge Tube Assembly	16-0349	1
9	Inlet Tube Assembly	16-0345	1	19	Housing- Right Side	16-0350	1
10	Valve Body	N/A	1		Repair Kit (Inc. 4-8, 11-12, 16)	70-0213	

CONTROL BOX ASSEMBLY (230 VOLT) (AFTER SERIAL #10154637)

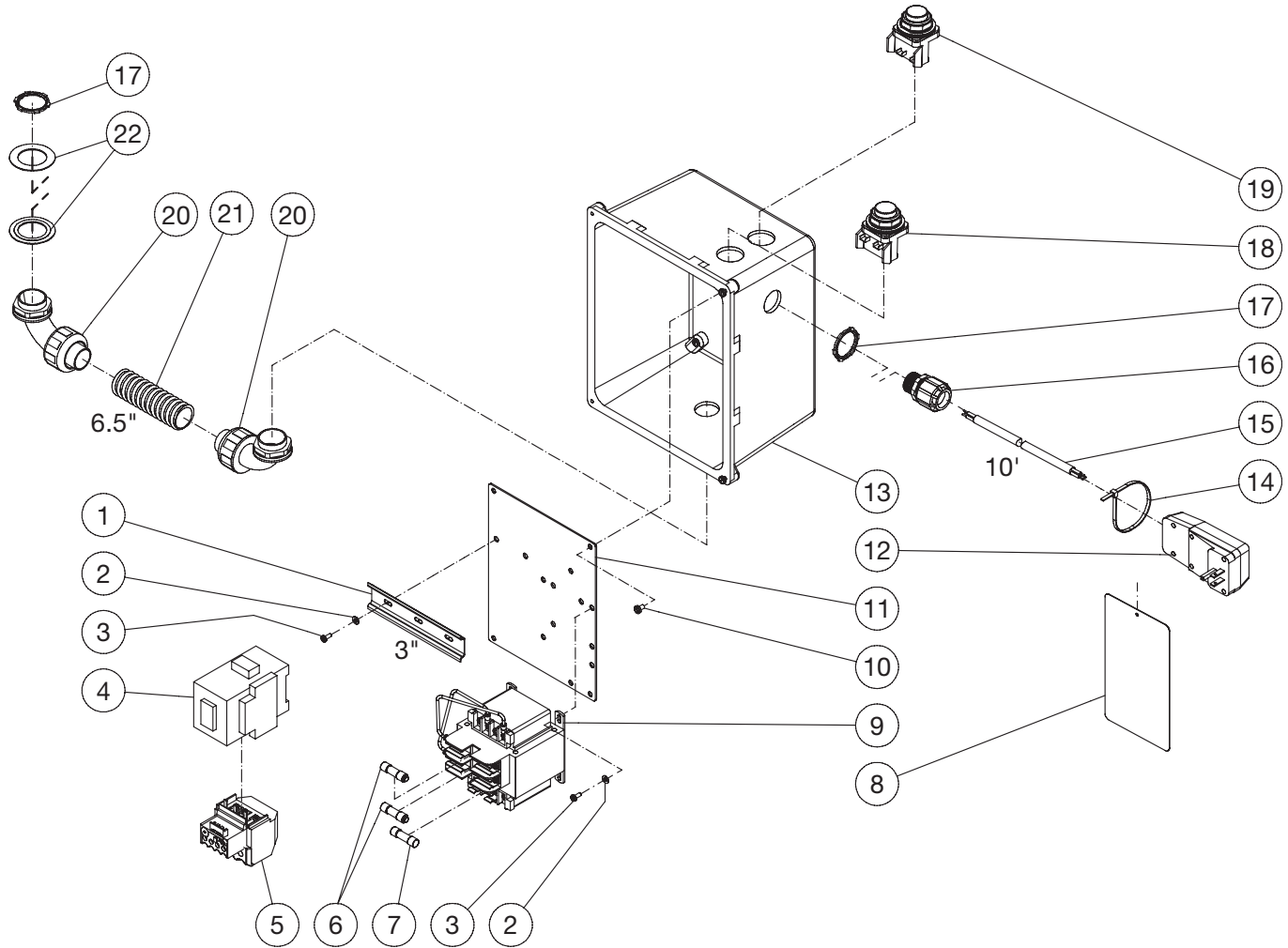

CW-A-0001 021022 JJR			
CONTROL BOX ASSEMBLY			
ITEM	DESCRIPTION	PART #	QTY
1	DIN RAIL *(ONE FOOT REQUIRED)	32-0316	1
2	WASHER	28-0010	6
3	BOLT	27-8927	6
4	CONTACTOR 45 AMP	32-0328	1
5	OVERLOAD RELAY 30-45A	32-0485	1
6	FUSE	32-0469	2
7	FUSE	32-0619	1
8	TAG - WARNING RISK OF ELECTROCUTION	34-1035	1
9	TRANSFORMER	32-0618	1
10	ISOLATION PLATE SCREW (WITH ELECTIC BOX)	-	4
11	PLATE	20-1293A06	1
12	PLUG	32-0647	1
13	ELECTRIC BOX	32-1119	1
14	CABLE TIE	33-0022	1
15	CORD *(TEN FEET REQUIRED)	32-0123	1
16	CORD RELIEF	9-0048	1
17	NUT	32-0515	2
18	SWITCH - RED	32-0306	1
19	SWITCH - GREEN	32-0305	1
20	CONDUIT ELBOW	32-0907	2
21	CONDUIT FLEX *(SEVEN FEET REQUIRED)	32-0908	1
22	REDUCING WASHER	32-1341	2
-	WIRE *(SEVEN FEET REQUIRED)	32-0501	1
-	WIRE *(THREE FEET REQUIRED)	32-0622	1
*MUST ORDER IN ONE FOOT LENGTHS			

WIRING SCHEMATIC (230 VOLT)

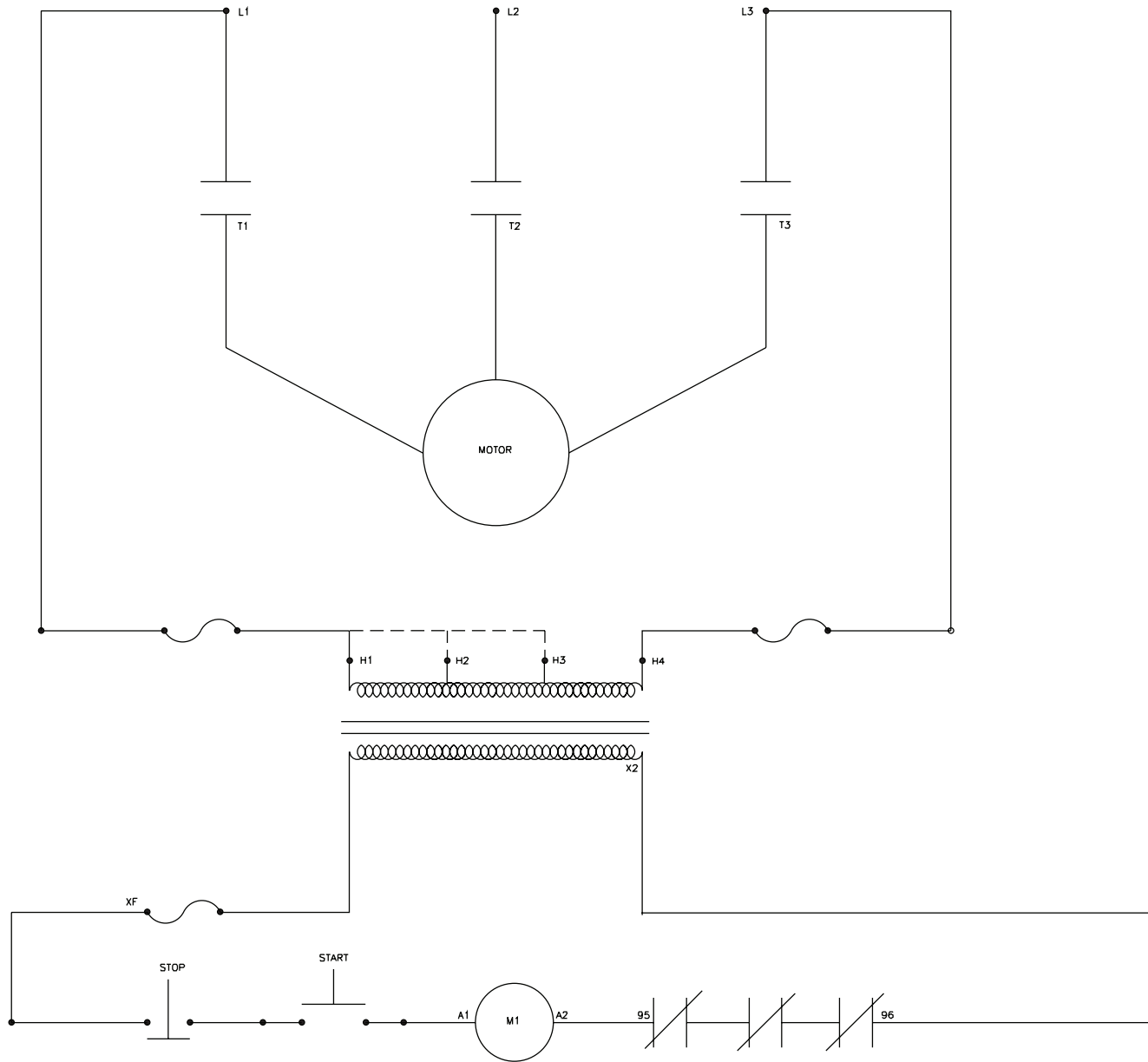

CW-WD-0001

WIRING DIAGRAM (230 VOLT)

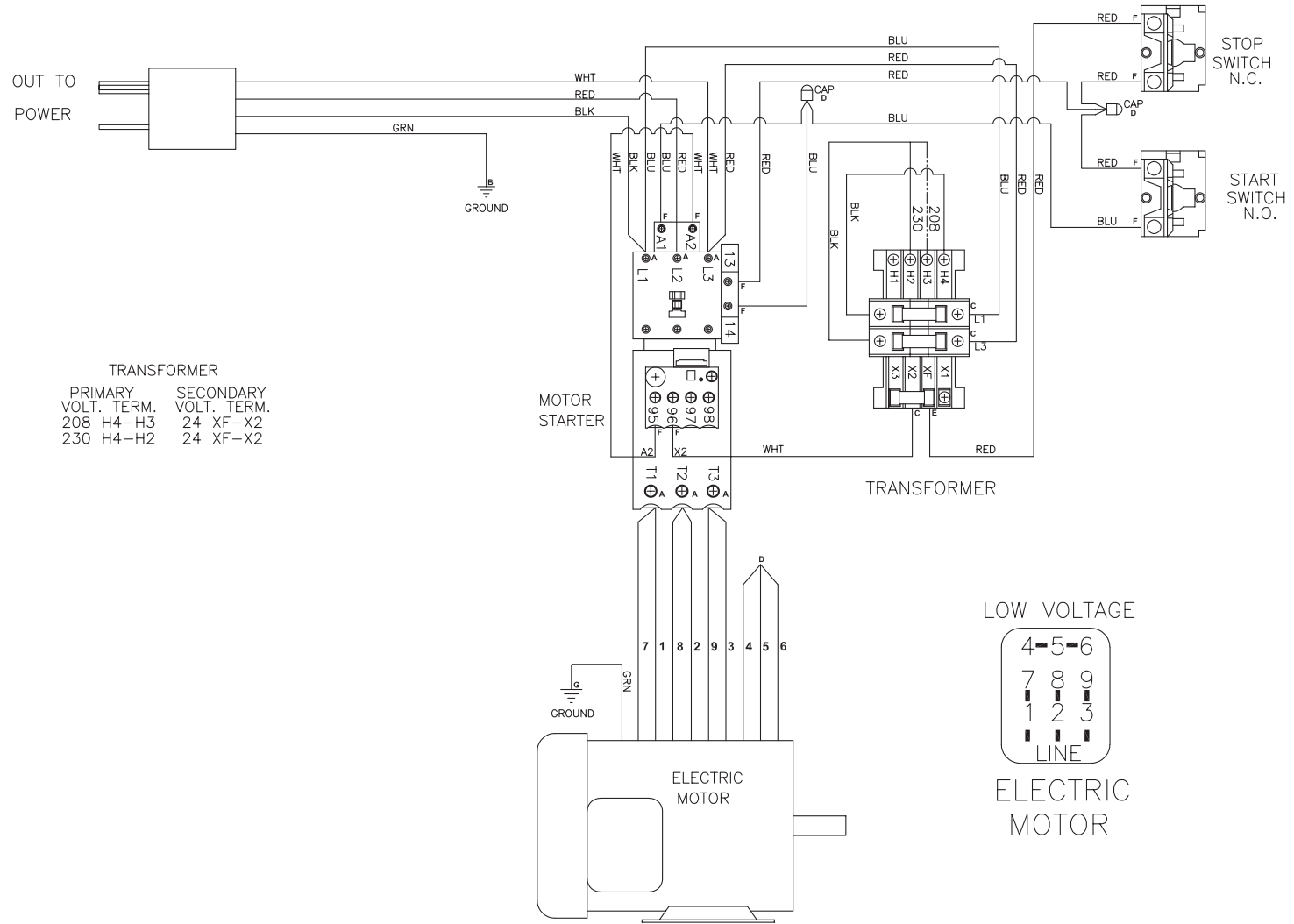

CW-WD-0002 120517 JRC

CONTROL BOX ASSEMBLY (CX-0057 OPTION) (460 VOLT)

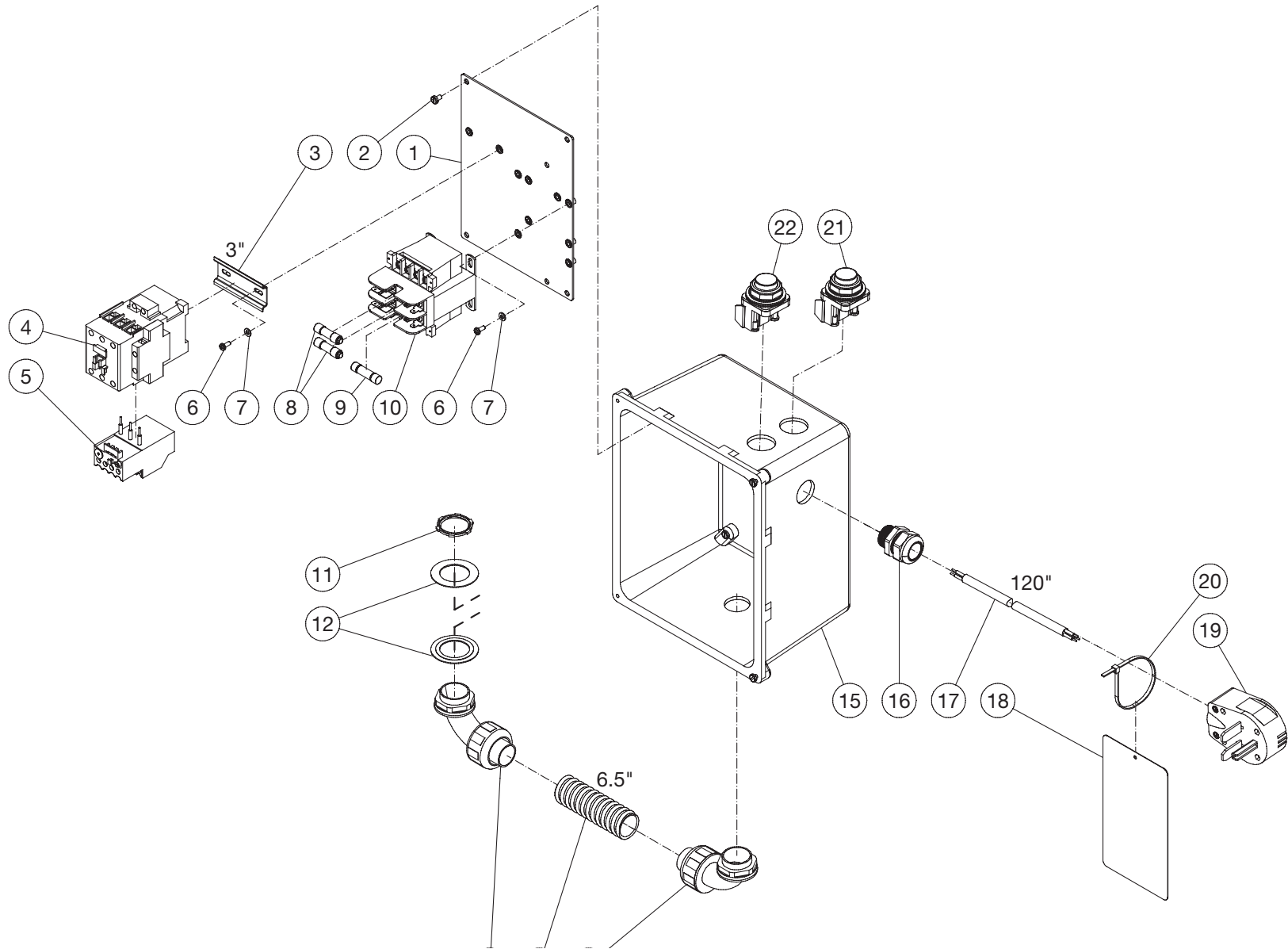

CW-A-0002 022422

CONTROL BOX ASSEMBLY (460V)			
ITEM	DESCRIPTION	PART #	QTY
1	ELECTRIC PANEL	20-1293A06	1
2	BOLT (W/ BOX)	N/A	1
3	DIN RAIL *(ONE FOOT REQUIRED)	32-0316	1
4	CONTACTOR - 30AMP	32-0597	1
5	OVERLOAD RELAY	32-1076	1
6	BOLT	27-8927	6
7	WASHER	28-0010	6
8	FUSE	32-0325	2
9	FUSE	32-0323	1
10	TRANSFORMER	32-0313	1
11	NUT	32-0515	1
12	REDUCING WASHER	32-1341	2
13	CONDUIT ELBOW	32-0907	2
14	CONDUIT FLEX *(ONE FOOT REQUIRED)	32-0908	1
15	ELECTRIC BOX	32-1119	1
16	CORD RELIEF	9-0046	1
17	CORD *(TEN FEET REQUIRED)	32-0023	1
18	TAG - WARNING RISK OF ELECTROCUTION	34-1035	1
19	PLUG	32-0146	1
20	CABLE TIE	33-0022	1
21	SWITCH - RED	32-0306	1
22	SWITCH - GREEN	32-0305	1
*MUST ORDER IN ONE FOOT LENGTHS			

WIRING SCHEMATIC (460 VOLT)

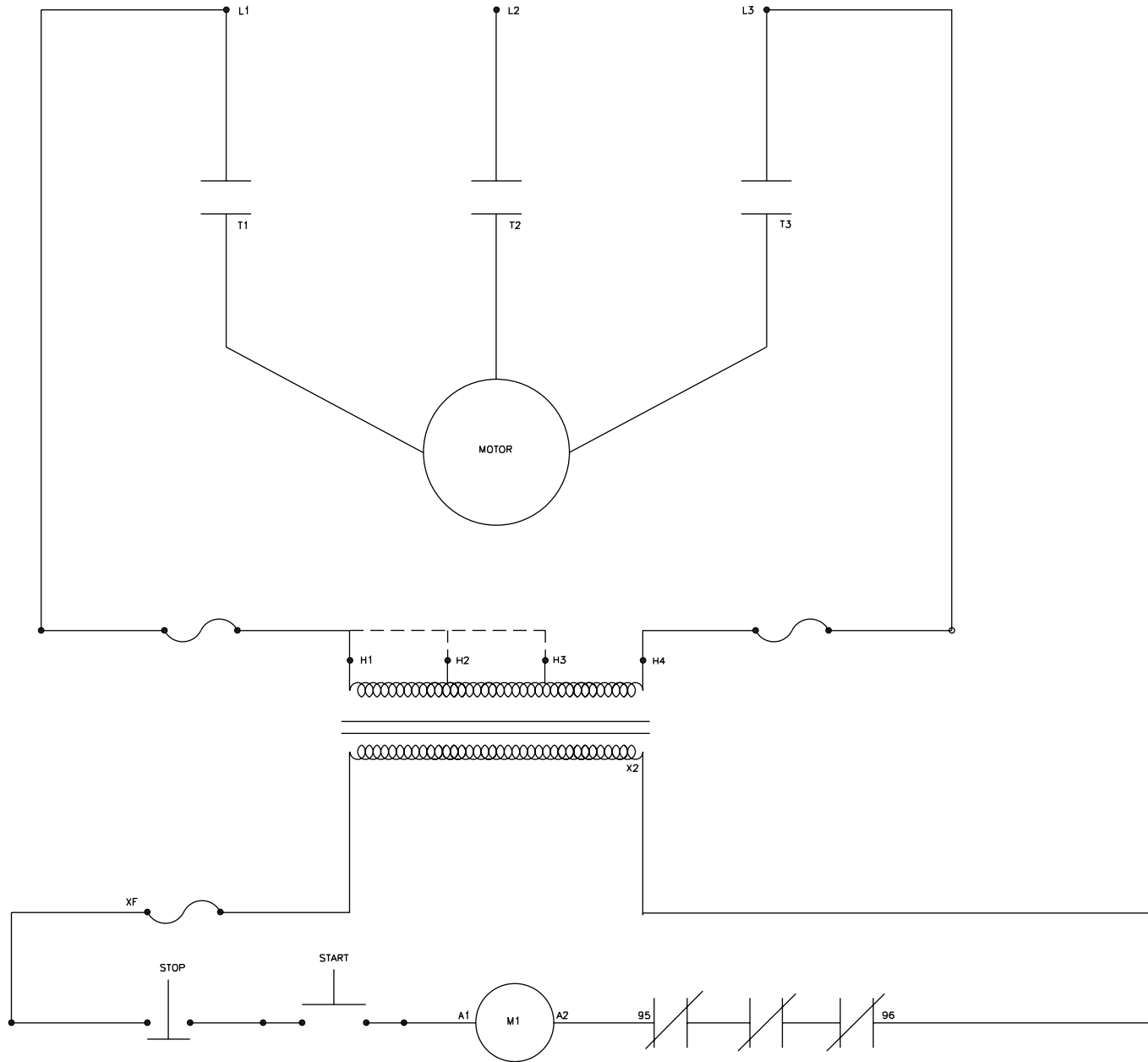

CW-WD-0001-112700-RD

WIRING DIAGRAM (460 VOLT)

