

INSTRUCTIONS FOR ASSEMBLY, OPERATION, SERVICING & STORAGE

24/36 GALLON TRAILER SPRAYERS



TABLE OF CONTENTS

24 GALLON	TOOLS REQUIRED & INCLUDED HARDWARE	3
	SPRAYER COMPONENTS	3
	24 GALLON TRAILER SPRAYER ASSEMBLY	4
36 GALLON	TOOLS REQUIRED & INCLUDED HARDWARE	8
	SPRAYER COMPONENTS	8
	36 GALLON TRAILER SPRAYER ASSEMBLY	9
	IMPORTANT SAFETY INFORMATION	12
	GENERAL CHEMICAL SAFETY	12
	BEFORE SPRAYING	13
	DURING SPRAYING	13
	AFTER SPRAYING	13
	OPERATION - PREPARING & USING SPRAYER	13
	PREPARING SPRAYER	14
	USING SPRAYER	14
	SPOT SPRAYING	14
	BROADCAST SPRAYING	14
	OPERATION - CLEANING, DECONTAMINATING & STORAGE	15
	TROUBLESHOOTING	16
	TROUBLESHOOTING TABLE	16
	24 GALLON PRAYER BREAKDOWNS	17
	36 GALLON PRAYER BREAKDOWNS	18

PRODUCT INFORMATION

When contacting us for replacement parts, accessories or warranty work, please be sure to have the following information available...

Date of Purchase: _____

Place of Purchase: _____

Model# of Sprayer: _____

(Model # can be found above UPC barcode on packaging)

INTRODUCTION

Congratulations on the purchase of your 12 Volt Trailer Sprayer. This sprayer has been manufactured to provide years of dependable and efficient use in spraying a wide range of agricultural pesticides, herbicides and other non-flammable liquids.

IMPORTANT NOTE:
THE PURPOSE OF THIS MANUAL IS TO ASSIST YOU IN THE ASSEMBLY, OPERATION, SERVICING AND STORAGE OF YOUR SPRAYER. PLEASE READ THROUGH THIS MANUAL COMPLETELY TO FULLY UNDERSTAND HOW TO OPERATE AND MAINTAIN YOUR EQUIPMENT. KEEP YOUR MANUAL IN A SAFE, CONVENIENT PLACE FOR FUTURE REFERENCE. ALWAYS MENTION THE MODEL AND PART NUMBER IN ANY CORRESPONDENCE.

WARRANTY

Sprayers sold shall be warranted from defects in workmanship and material when used within the service and scope for which they were designed for a period of two years from date of purchase. Warranty covers replacement parts ONLY.

Contact our Spraying Division for warranty parts at 800.825.5397. DO NOT RETURN PRODUCT TO YOUR DISTRIBUTOR/DEALER. Please have original proof of purchase, model number of sprayer and part number of part from illustrated parts breakdown in this manual.

TOOLS REQUIRED

800.825.5397

TOOLS ARE NOT INCLUDED WITH PURCHASE OF SPRAYER.



1/2" SOCKET WRENCH

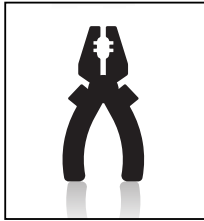

PLIERS



TEFLON TAPE

CLOSELY INSPECT ALL CONTENTS IN THE SHIPPING CARTON

- If you have damaged components:
Contact the freight company that delivered the unit to file a claim.
- If you have missing components:
Contact us at 800.825.5397.

**THESE INSTRUCTIONS ARE
FOR 24 GALLON TRAILER
SPRAYER MODELS.**

**36 GALLON TRAILER
SPRAYER INSTRUCTIONS
CAN BE FOUND ON PAGE 8
OF THIS MANUAL.**

INCLUDED HARDWARE

**NOTE: SOME PARTS ARE
SHIPPED INSIDE THE TANK!**

SPRAYER COMPONENTS



Sprayer Tank Assy (1)



Spray Wand Assy (1)
SG-2218-38-RUB15



Wheel (2)
TWA13X5-6



Gauge (1)
1124DAB100



Cotter Pin (2)
33-100091



Axel (1)
31-100520



Wire Harness (1)
33-103233

SPRAYER COMPONENTS



Snapper Hose Clamp (2)
SHC-F



Tongue (1)
32-100040



Tongue Pin (1)
905PA



Boom Brackets (2)
31-100525 &
31-100526



Wheel Spacer (2)
075-8-00P



Bracket Bolts (4)



Hex Nut (4)

1. PARTS

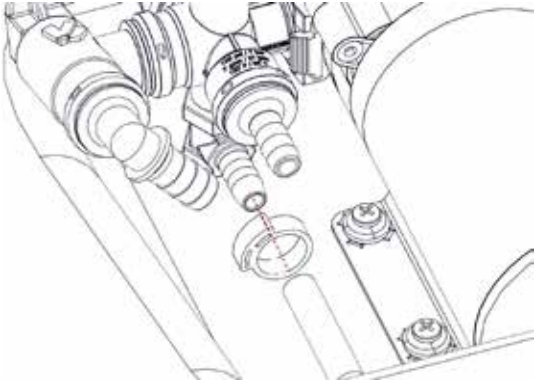

TOOLS

Insert Spray Gun Hose through Snapper Hose Clamp and press the Spray Gun hose onto the bottom Hose Barb.

Close Snapper Hose Clamp with Pliers.

Attaches Spray Gun Hose to Pump



2. PARTS



TOOLS

None

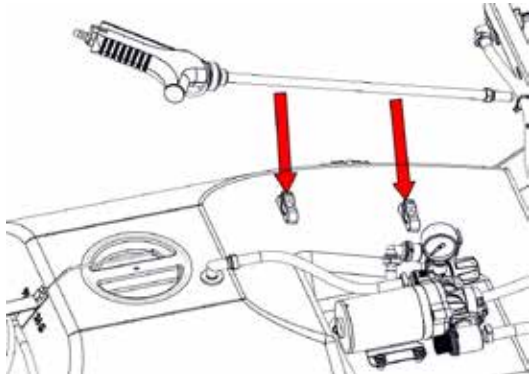

Press the Spray Gun into the Gun Clips to secure it on the Tank.

Attaches Spray Gun to Tank

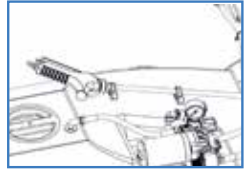

3. PARTS

TOOLS

None

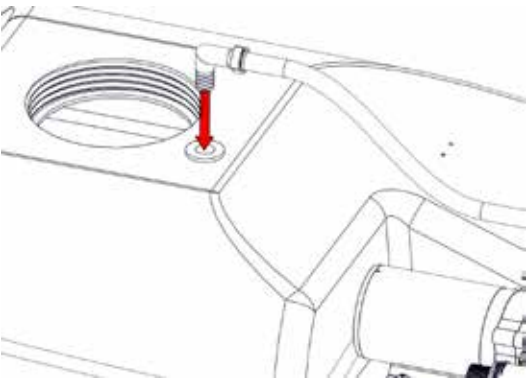

Press the Tank Return Hose Barb into the Top Hat Grommet near the Tank Lid until it is flush with the Tank.

Attaches Return to Tank



4. PARTS



TOOLS

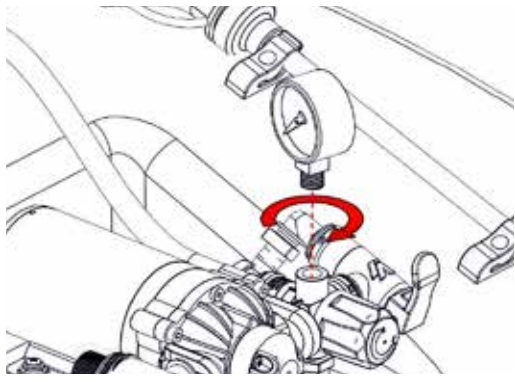







NOTE: The threads of the pressure gauge may require the use of Teflon Tape (not included) to prevent a small amount of leakage.

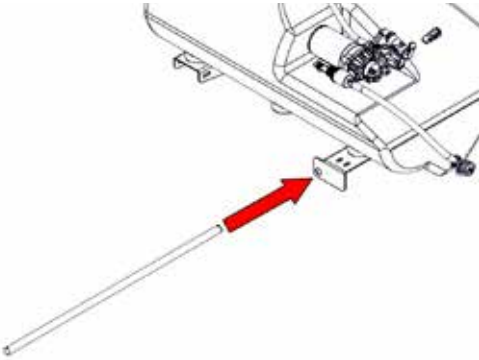

Twist Pressure Gauge, by hand, into open port on top of the Pressure Regulator Assembly until fully seated.

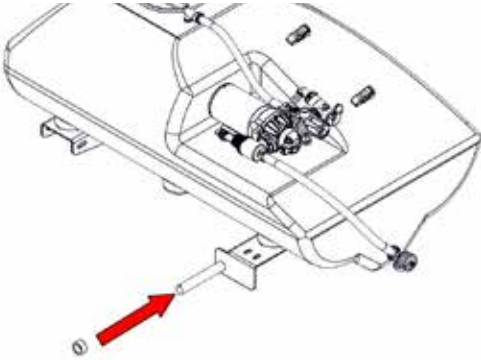

Attaches Pressure Gauge to Pump

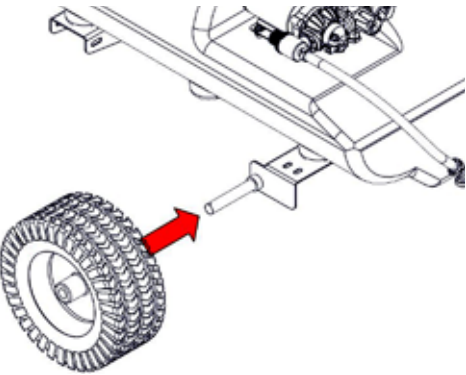

5.	PARTS	
TOOLS		
None	<p data-bbox="142 673 779 738">Insert Axle through Frame with equal amount of overhang on both sides.</p> <p data-bbox="850 634 989 651">Attaches Axle to Frame</p> 	

6.	PARTS	
TOOLS		
None	<p data-bbox="1144 673 1640 706">Slide the Wheel Spacers onto each side of the Axle.</p> <p data-bbox="1816 634 1997 651">Attaches Wheel Spacer to Axle</p> 	

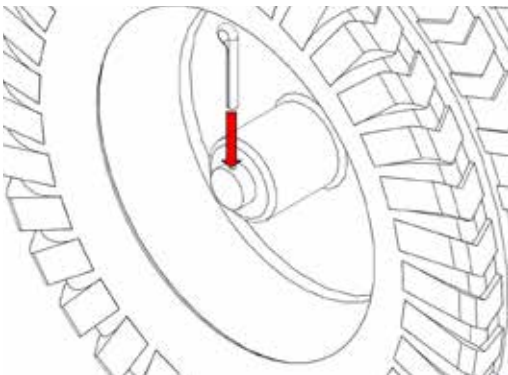
7.	PARTS	
TOOLS		
None	<p data-bbox="142 1406 632 1438">Slide Wheel Assemblies onto each side of the Axle.</p> <p data-bbox="142 1471 709 1503">Be sure Valve Stems are facing out from the Sprayer Tank.</p> <p data-bbox="840 1373 978 1390">Attaches Wheel to Axle</p> 	

8.	PARTS	
TOOLS		
	<p data-bbox="1144 1406 1682 1438">Insert the Cotter Pins through the Axle as shown above.</p> <p data-bbox="1144 1471 1766 1503">Use a Pliers to bend one end of each cotter pin to secure to Axle.</p> <p data-bbox="1850 1365 1988 1382">Secures Wheel to Axle</p> 	

9. PARTS



TOOLS

None

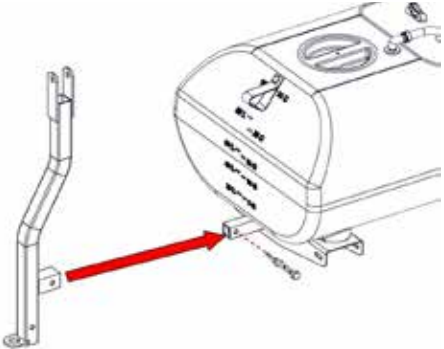

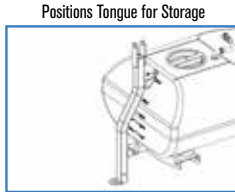

Slide Tongue onto the Hitch Post as shown above for storage.
Secure the Tongue with the included Hitch Pin.



10. PARTS

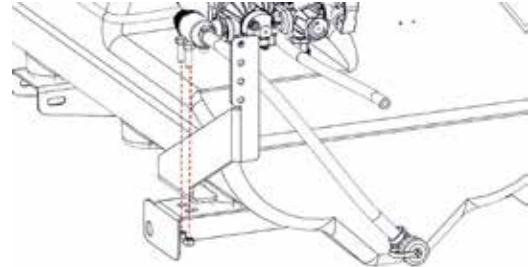

TOOLS



Align the Left Boom Bracket to the Frame as shown above.
Insert Bracket Bolts and secure using Socket Wrench and Hex Nuts

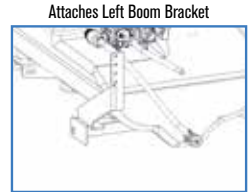

11. PARTS

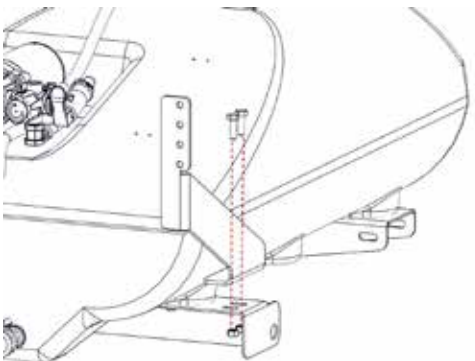

TOOLS



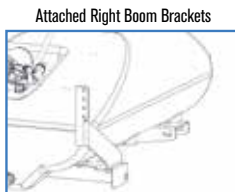

Align the Right Boom Bracket to the Frame as shown above.
Insert Bracket Bolts and secure using Socket Wrench and Hex Nuts

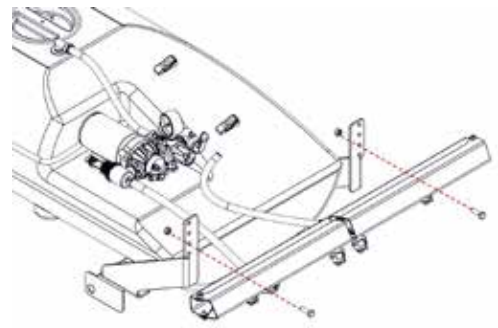

12. PARTS

TOOLS

Place Boom Mounting Bolts through holes in the Boom Assembly and into the Boom Brackets.
Secure using Socket Wrench and Hex Nuts.

NOTE: Boom style may vary. SSBK-420 shown. Follow your Boom Assembly Card for any changes to installation.

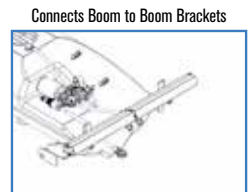

13.

PARTS



TOOLS

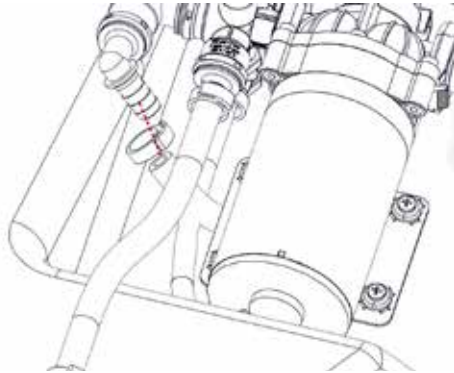

Attached Boom to Shut-Off Valve

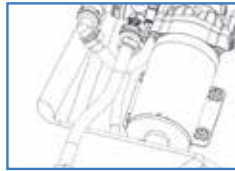

Insert the Boom Hose through the Snapper Hose Clamp.

Press the Boom Hose onto the open Elbow Hose Barb on the Boom Shut-Off Valve.

Close the Snapper Hose Clamp with Pliers.

14.

PARTS



TOOLS

None

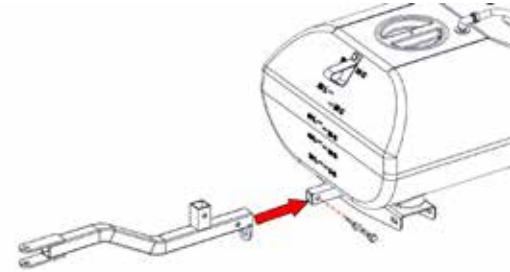

Positions Tongue for Towing

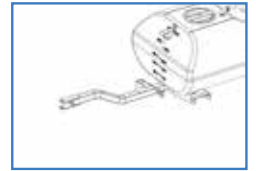

Open the Hitch Pin and remove from the Tongue.

Change the Tongue position as shown above and reinsert the Hitch Pin to secure the Tongue for towing.

B.

BREAKDOWNS

Sprayer Breakdowns available on Page 17.

TOOLS ARE NOT INCLUDED WITH PURCHASE OF SPRAYER.



1/2" SOCKET WRENCH

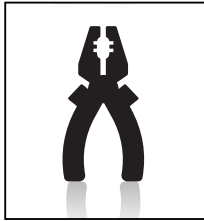

PLIERS

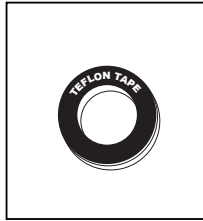

TEFLON TAPE

CLOSELY INSPECT ALL CONTENTS IN THE SHIPPING CARTON

- If you have damaged components:
Contact the freight company that delivered the unit to file a claim.
- If you have missing components:
Contact us at 800.825.5397.

**THESE INSTRUCTIONS ARE
FOR 36 GALLON TRAILER
SPRAYER MODELS.**

**24 GALLON TRAILER
SPRAYER INSTRUCTIONS
CAN BE FOUND ON PAGE 3
OF THIS MANUAL.**

INCLUDED HARDWARE

**NOTE: SOME PARTS ARE
SHIPPED INSIDE THE TANK!**

SPRAYER COMPONENTS

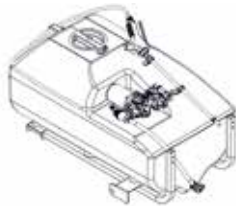

Sprayer Tank Assy (1)



Wheel (2)
TWA16X6.50-8



Wheel Spacer (2)
075-8-00P



Gauge (1)
1124DAB100



Cotter Pin (2)
33-100091



Axel (1)
31-100520



Wire Harness (1)
33-103233

SPRAYER COMPONENTS



Snapper Hose Clamp (2)
SHC-F



Spray Wand Assy (1)
SG-2218-38-RUB15



Tongue (1)
32-100106



Tongue Bracket (1)
31-100519



Bracket Bolt (4)



Hex Nut (4)



Tongue Pin (2)
905PA

1.

PARTS

TOOLS

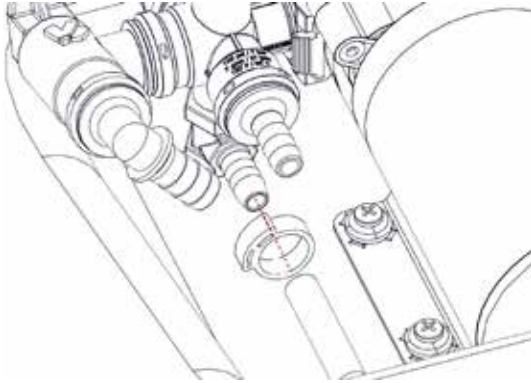

Attaches Spray Gun Hose to Pump

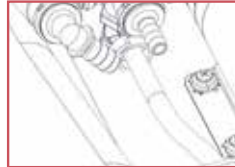

Insert Spray Gun Hose through Snapper Hose Clamp and press the Spray Gun hose onto the bottom Hose Barb.

Close Snapper Hose Clamp with Pliers.

2.

PARTS

TOOLS

None

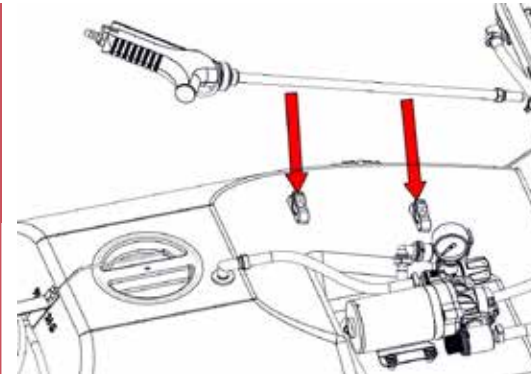

Attaches Spray Gun to Tank

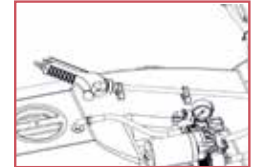

Press the Spray Gun into the Gun Clips to secure it on the Tank.

3.

PARTS

TOOLS

None

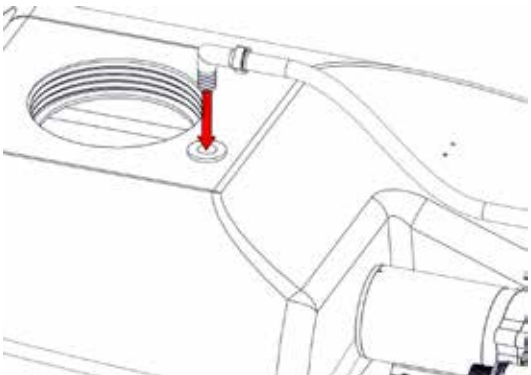

Attaches Return to Tank



Press the Tank Return Hose Barb into the Top Hat Grommet near the Tank Lid until it is flush with the Tank.

4.

PARTS

TOOLS

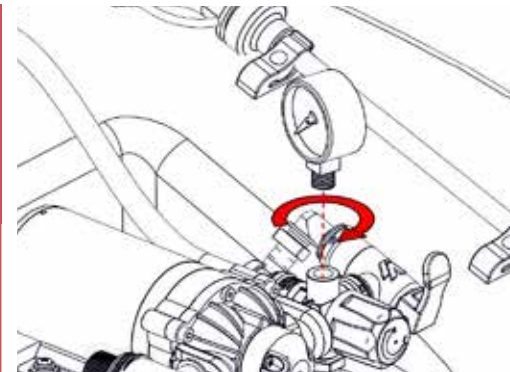

NOTE: The threads of the pressure gauge may require the use of Teflon Tape (not included) to prevent a small amount of leakage.

Attaches Pressure Gauge to Pump



Twist Pressure Gauge, by hand, into open port on top of the Pressure Regulator Assembly until fully seated.

5. PARTS

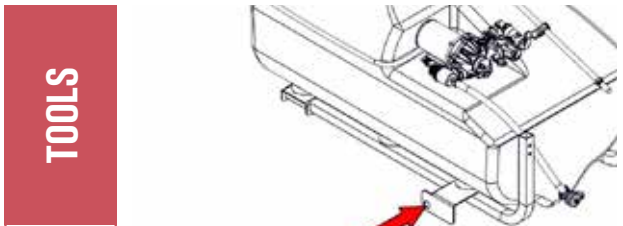

TOOLS
None

NOTE: Axle may be very snug, requiring several taps with wood block or rubber mallet to persuade into position.

Insert Axle through Frame with equal amount of overhang on both sides.

Attaches Axle to Frame



6. PARTS

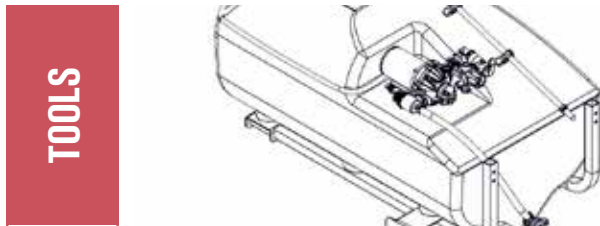

TOOLS
None

Slide the Wheel Spacers onto each side of the Axle.

Attaches Wheel Spacer to Axle



7. PARTS

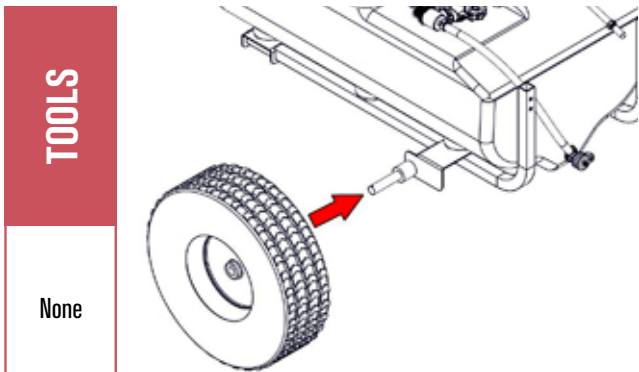

TOOLS
None

Slide Wheel Assemblies onto each side of the Axle.

Be sure Valve Stems are facing out from the Sprayer Tank.

Attaches Wheel to Axle



8. PARTS

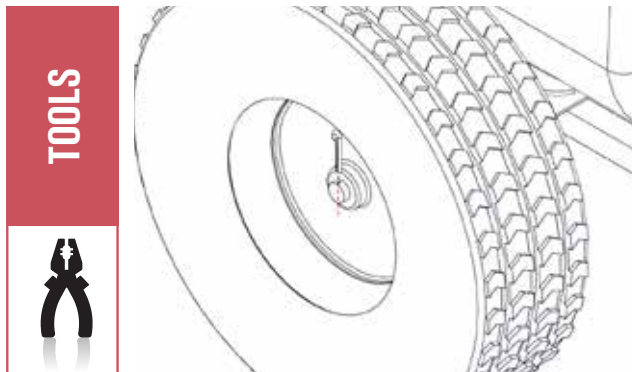

TOOLS

Insert the Cotter Pins through the Axle as shown above.

Use a Pliers to bend one end of each cotter pin to secure to Axle.

Secures Wheel to Axle



9.

PARTS

TOOLS

None

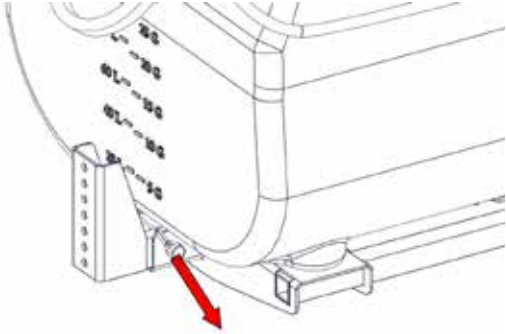

Remove the Hitch Pin to release the Tongue from the storage position.

Frees Tongue from Frame



10.

PARTS

TOOLS

None

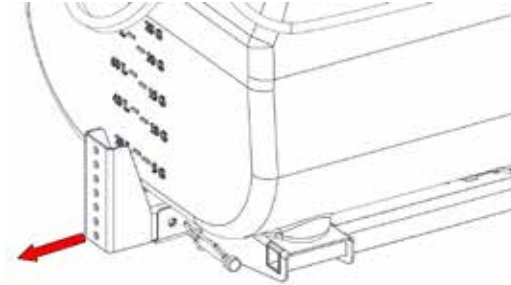

Slide the Tongue out from Frame.

Align tow position holes in the Tongue with the holes in the Frame.

Aligns Tongue for Towing Position

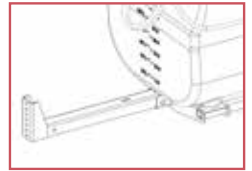

11.

PARTS

TOOLS

None

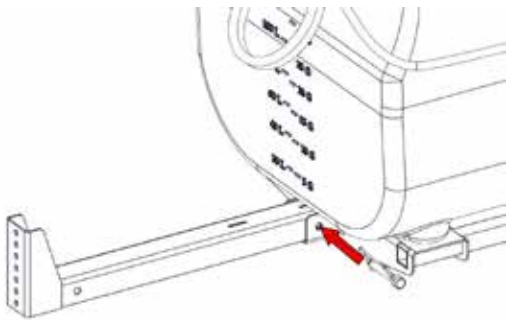

Secure the Tongue in the tow position with the Hitch Pin

Attaches Tongue in Tow Position

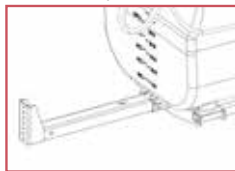

12.

PARTS

TOOLS

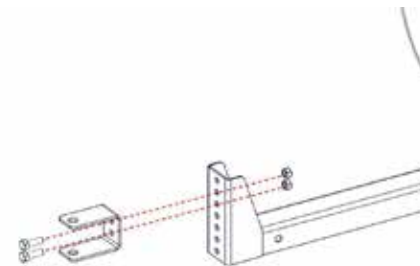

Align holes in Tongue Bracket to holes in the Hitch.

Insert Bracket Bolts and secure with Hex Nuts using Socket Wrench.

Connects Tongue to Tongue Bracket



13.

PARTS

TOOLS

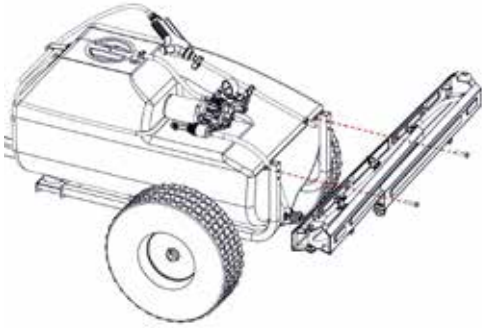

NOTE: Boom style may vary. SSBK-620 shown. Follow your Boom Assembly Card for any changes to installation.

Place Boom Mounting Bolts through holes in the Boom Assembly and into the Boom Brackets.

Secure using Socket Wrench and Hex Nuts.

Attached Boom to Shut-Off Valve



OPERATION - IMPORTANT SAFETY INFORMATION

Now that you have assembled your sprayer, there is some important safety and health information you need to know with regard to handling and spraying chemicals.



TAKE NOTE! THIS SAFETY ALERT SYMBOL FOUND THROUGHOUT THIS SECTION IS USED TO CALL YOUR ATTENTION TO INSTRUCTIONS INVOLVING YOUR PERSONAL SAFETY AND THE SAFETY OF OTHERS. FAILURE TO FOLLOW THESE INSTRUCTIONS CAN RESULT IN PROPERTY DAMAGE, INJURY OR DEATH.

NOTE: THE USE OF CORROSIVE OR FLAMMABLE CHEMICALS IN THIS SPRAYER IS HAZARDOUS AND WILL ALSO VOID YOUR WARRANTY.

B.

BREAKDOWNS

Sprayer Breakdowns available on Page 18.

GENERAL CHEMICAL SAFETY

**WARNING**

Pesticides are hazardous chemicals. Heed the warning below and follow all instructions carefully. Improper handling of chemicals can result in serious injury or illness, or cause damage to humans, animals or the general environment.

BEFORE SPRAYING

- **Test with Fresh Water:** Before adding and spraying chemicals, always test sprayer with fresh water to make sure there are no cracks or leaks and equipment is performing correctly.
- **Sprayer Prep:** ALWAYS inspect and prepare the sprayer before use according to the directions provided in this manual.
- **Keep Sprayer Off:** Do not turn power on to the sprayer until ready to spray in order to avoid unintentional spray release.
- **Broadcast Nozzle Down:** Make sure the broadcast nozzle is oriented to spray straight down before starting the sprayer.
- **Wind Speed:** NEVER spray when wind exceeds 4 MPH in order to minimize spray drift.
- **Clear Area:** ALWAYS keep work area clear of people and pets. Post warning notices to restrict access by the public for the period recommended on chemical label.
- **Operator Age:** To operate this sprayer, you must be 16 years of age or older. Pesticides are extremely toxic to children.
- **Chemical Label:** ALWAYS READ and FOLLOW all chemical label instructions.
- **State & Federal Laws:** ALWAYS refer to state and federal regulations with regard to the application of a particular chemical you plan to use.
- **Flammables:** NEVER use any flammable chemicals, such as diesel fuel, in the sprayer.
- **Corrosives:** DO NOT use corrosive chemicals, such as bleach, in the sprayer. They can weaken the sprayer and its parts, resulting in leaks. Always check with chemical manufacturer for compatibility with sprayer.
- **Emergency Procedures:** Before handling chemicals, carefully review the "Statement of Practical Treatment" on the chemical label.

DURING SPRAYING

- **Over Application:** DO NOT over apply pesticide. Apply at a rate recommended by chemical manufacturer. Excess pesticide can be dangerous to humans, damage desirable plants, and contaminate soil and water sources.
- **Never Point Spray Gun:** NEVER point the spray gun at people or animals.
- **Children & Pets:** ALWAYS exercise extra caution when spraying near areas accessible to children and pets.
- **Eating & Smoking:** DO NOT eat, drink, smoke, rub your eyes or touch any part of your bare skin while handling chemicals and spraying.
- **Heat & Flames:** DO NOT spray near open flames or sources of heat.
- **Spills:** ALWAYS clean up spills immediately per instructions on the chemical label.
- **Unattended:** ALWAYS turn off vehicle and set brake or block wheels, turn off power to sprayer, and relieve system pressure before leaving sprayer unattended.

AFTER SPRAYING

- **Clean Sprayer:** ALWAYS clean the sprayer immediately after use according to the directions provided in this manual.
- **Decontaminate:** ALWAYS decontaminate yourself immediately after you are finished with spraying and handling chemicals. Wash all exposed areas of the body with soap and water. Remove and launder clothing.
- **Chemical Disposal & Storage:** ALWAYS dispose or store remaining chemicals properly as recommended on the chemical label.
- **Health Monitoring:** Monitor the health of operators who are frequently exposed to pesticides, as recommended by the chemical label.



WARNING

Chemical spills, sprayer leaks, personal contamination, and poisoning are accident situations which you may encounter. All require an immediate response. In the event these accidents take place, follow first aid instructions on the chemical label and contact poison control for further advice (1-800-222-1222). If victim collapses or isn't breathing CALL 911.

OPERATION - PREPARING & USING SPRAYER

If the sprayer has been used previously, it must be prepared BEFORE EACH SUBSEQUENT USE.



WARNING

Read the following instructions carefully for inspecting and using the sprayer. Damaged or clogged equipment could result in leaks or uncontrolled spray. Leaks could result in injury to the operator or bystanders from chemical exposure, or cause damage to the environment.

IMPORTANT NOTE:

THIS SPRAYER IS NOT CERTIFIED FOR USE IN DISPENSING POTABLE WATER OR OTHER CONSUMABLE LIQUIDS.

PREPARING SPRAYER

- **Review Safety Information:** Review safety information in this manual and manufacturer chemical label before use.
- **Sprayer Attachment:** Ensure the sprayer is securely attached to the vehicle.
- **Empty Tank:** Ensure the sprayer has been thoroughly flushed and drained of all residual chemical prior to uses.
- **Clean Suction Strainer:** Clean suction strainer of any chemical residue with fresh water. USE RUBBER GLOVES for extra safety.
- **Inspect & Test:** Inspect the tank and components for any cracks or leaks. Replace any damaged parts. **IMPORTANT:** After any repair, **ALWAYS** test for leaks with water one final time before use.
- **Check Drain Cap:** Before filling tank, ensure drain cap at bottom of tank is securely tightened.

USING SPRAYER

- **Protective Equipment:** **ALWAYS** wear protective equipment as directed on the chemical label.
- **Assess Wind & Area Conditions:** Before spraying, determine if wind conditions are suitable. **DO NOT** spray if wind speeds are greater than 4 MPH. **DO NOT** spray if bystanders are in the intended area and verify that area is in a well-ventilated outdoor area.
- **Power Off:** Before filling tank, make sure power to the sprayer and the vehicle is off and brakes are set to prevent unintended movement.
- **Filling Tank:** Remove sprayer tank lid and add chemical/water dilution ratios that are called out by chemical label. Ensure chemical is thoroughly mixed with a stirring device and then securely thread tank lid back on sprayer tank.

USING SPRAYER (CONTINUED)

- **Broadcast Boom Valve:** Close broadcast boom valve to prevent accidental spray release.
- **Turn On Power:** Connect the wire harness to vehicle battery and turn the remote switch to the “On” position.

SPOT SPRAYING

- **Spot Spraying:** To spot spray, pull the gun trigger. Make sure nozzle of gun is pointed towards vegetation in need of spraying.
- **Adjustable Nozzle:** Twist the spray nozzle to adjust from a straight stream to wide pattern mist.
Note: It is not unusual for the operator to be exposed to chemical drips while adjusting the nozzle – use chemical resistant gloves when twisting.

BROADCAST SPRAYING

- **Open Boom Valve:** Open up boom valve to allow flow from tank to boom kit.
- **Ensure Correct Pattern:** Make sure boom nozzle is pointed straight down. If not, loosen the nozzle retaining nut and adjust orientation of the boom nozzle opening to point straight down.
Note: It is not unusual for the operator to be exposed to chemical drips while adjusting the broadcast nozzle. Chemical resistant gloves should be worn.
- **Open Boom Valve:** Open up boom valve to allow flow from tank to boom kit.
- **Uniform Coverage:** To ensure proper coverage, follow the separate boom kit manual that came with your sprayer.
- **Broadcast Spraying:** Turn the remote switch to the “ON” position to being spraying.

OPERATION - CLEANING, DECONTAMINATING & STORAGE

When done using the sprayer, it is always important to clean the sprayer and decontaminate yourself. Do not store the sprayer with chemicals in the tank, as it is unsafe and could also result in damage.



WARNING

Clean-up and decontamination procedures must be followed after each use. Improper equipment clean-up and disposal of chemicals can result in dangerous chemical exposure to humans and the environment, as well as equipment damage. Personal decontamination is required after spraying to minimize unsafe exposure to chemicals and potential illness.

CLEANING & DECONTAMINATING SPRAYER

- **Drain Tank:** If there is excess pesticide left in tank, drain into a suitable container.
Note: when draining pesticides, be sure to wear protective gear such as rubber gloves and eye protection for increased safety.
- **Unused Chemical:** Properly store or dispose of unused chemical in its original, suitable container and make sure to follow chemical manufacturer's recommendations and according to local hazardous waste disposal regulations.
- **Flush Sprayer:** Flush sprayer per the chemical manufacturer's recommendations.
- **Decontaminate & Launder:** Decontaminate yourself after handling chemicals by removing clothing worn, washing exposed body parts with soap and water, and laundering clothing separately from other wash.

SPRAYER STORAGE

Prepare the sprayer for end-of-season storage by running RV anti-freeze through the system. This will keep internal parts lubricated, protect against corrosion, and keep the unit from freezing.

IMPORTANT NOTE:

ALLOWING YOUR SPRAYER TO FREEZE, WITHOUT TAKING PROPER WINTERIZATION STEPS, VOIDS YOUR WARRANTY.



WARNING

The sprayer will be damaged if it freezes. Protect the sprayer from freezing during storage by following instructions below.

PREPARING SPRAYER FOR STORAGE

- **Add Anti-Freeze:** Pour one gallon of RV anti-freeze into the sprayer tank.
- **Spray Briefly:** Turn on the pump motor and squeeze the gun trigger briefly until fluid sprays out.

REMOVING SPRAYER FROM STORAGE

- **Drain Anti-Freeze:** Drain the anti-freeze that is left in the tank through the tank drain port into a suitable container.
- **Flush with Water:** Fill tank with fresh water and have it run through system. Operate spray gun and boom until the system is completely flushed. Be sure to set up containers to capture the flushing of the anti-freeze.
- **Disposal:** Dispose of anti-freeze and flush water properly.

TROUBLESHOOTING

Here you will find troubleshooting steps for some of the most common issues users have with sprayers.



WARNING

Before troubleshooting or attempting to service your pump or sprayer, read the following safety rules to avoid accidental exposure to chemicals and the possibility of electric shock.

BEFORE ATTEMPTING TO SERVICE SPRAYER

- **Personal Protective Equipment:** Wear personal protective equipment as directed on the chemical label while servicing sprayer.
- **Review Troubleshooting Table:** Review the troubleshooting table to the right for the type of problem you are experiencing. DO NOT attempt to repair until reading remaining steps listed below are followed.
- **Empty & Flush Tank:** Empty the tank and flush the sprayer with water as directed in the section Cleaning, Decontaminating & Storage.
- **Disconnect Power/Relieve Pressure:** Disconnect power to the sprayer and be sure all system pressure is relieved by squeezing the gun trigger.
- **Perform Repairs:** Follow the directions provided in the troubleshooting table to repair the sprayer.
Note: Never try to unclog the sprayer nozzle by blowing through it.
- **Test after Repairs:** After repairs, ALWAYS test the sprayer for leaks with fresh water before using.

PROBLEM	CAUSE	SOLUTION
Pump Will Not Turn On	Bad Electrical Connection	Check Battery Connections
	Fuse Blown	Replace Fuse
	Short In Wire	Check Condition of Wires
	Low Voltage	Check Voltage
	Locked Drive	Replace Diaphragm Assembly
	Faulty Pressure Switch	Replace Pressure Switch
Pump Will Not Prime	Out of Product	Refill Supply Container
	Inlet Air Leak	Tighten Fittings or Replace Cracked Fittings
	Inlet/Outlet Tube Obstruction	Remove Obstruction
	Clogged Intake Valve	Remove Obstruction
	Low Voltage	Check Voltage
Low Pressure or Flow	Worn Spray Gun Nozzle	Replace Spray Gun
	Worn Boom Nozzle	Replace Boom Nozzle
	Worn Wobble Plate or Diaphragm	Replace Diaphragm Assembly
	Worn Pressure Switch	Replace Pressure Switch
	Inlet Air Leak	Tighten Fittings or Replace Cracked Fittings
	Inlet/Outlet Tube Obstruction	Remove Obstruction
	Clogged Intake Valve	Remove Obstruction
	Low Voltage	Check Voltage
Pump Leaks	Loose Fasteners	Tighten Fasteners
	Pump Seals Degraded	Replace Pump Head Assembly
	Leak In Diaphragm	Replace Diaphragm Assembly
Poor Spray Distribution	Clogged Intake Tube	Remove Obstruction
	Clogged Suction Strainer	Clean Suction Strainer
	Worn Spray Gun Nozzle	Replace Spray Gun
Pump Cycles While Not Spraying	Leak In the System	Tighten Leaking Hose Clamps, Fittings or Replace Spray Gun
	Faulty Pressure Switch	Replace Pressure Switch
	Low Voltage	Check Voltage
	Air Trapped In System	Purge Air From System
Rough Operation	Flexible Mounting Surface	Mount Pump On Rigid Surface
	Loose Pump Head	Tighten Fasteners
	Compressed Base Feet	Decompress Base Feet
	Rigid Plumbing	Plumb Pump with Flexible Plumbing

24 GALLON TRAILER FRAME BREAKDOWN

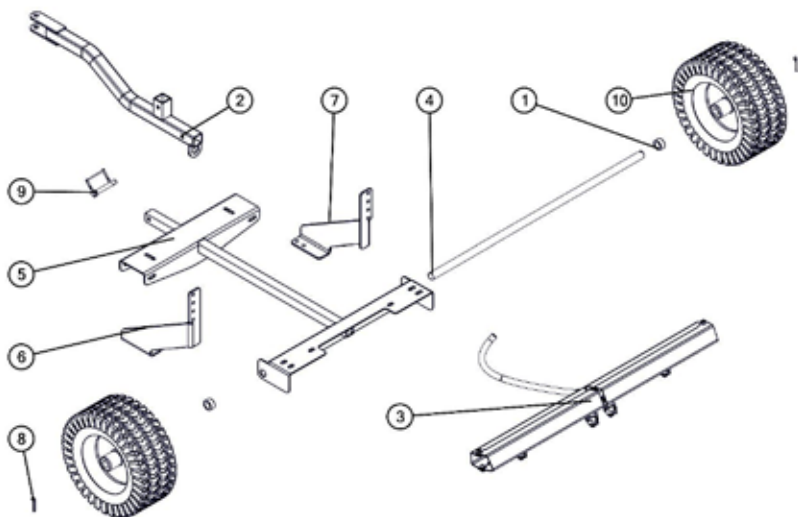

ID	Part Number	Description	Qty
1	075-8-00P	Wheel Spacer	2
2	32-100040	Two Position Tongue	1
3	34-140184 or 34-100001	420 Boom Assembly (shown) or 240 Boom Assembly	1
4	31-100520	Axle	1
5	32-100140	24 Gallon Lawn Sprayer Frame	1
6	31-100525	Left Boom Bracket	1
7	31-100526	Right Boom Bracket	1
8	33-100091	Cotter Pin	2
9	905PA	Lock Pin	1
10	TWA13X5-6	13" Wheel Assembly	2

24 GALLON TRAILER TANK BREAKDOWN

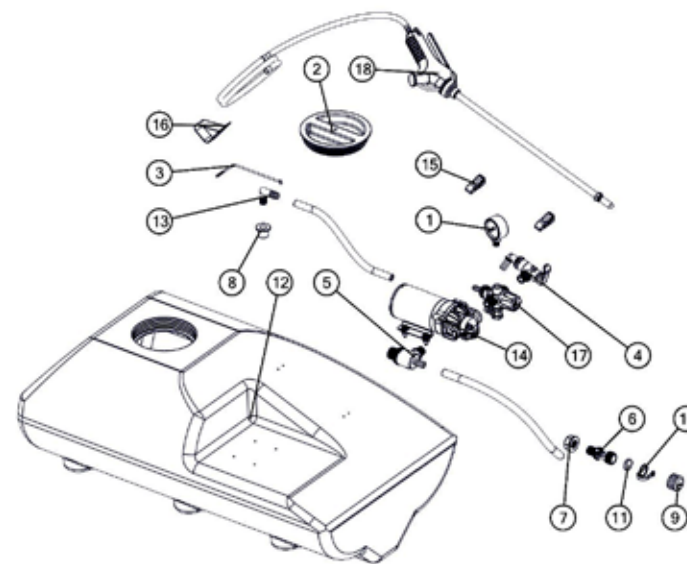

ID	Part Number	Description	Qty
1	1124DAB100	0-100 PSI Pressure Gauge	1
2	31-100340	Recessed Tank Lid	1
3	31-100341	Tank Lid Tether	1
4	34-140161	Boom Shut-Off Valve	1
5	34-140164	Inline Strainer	1
6	31-400012	Inlet/Drain Fitting	1
7	31-400013	Inlet/Drain Fitting Nut	1
8	33-100098	Top Hat Grommet	1
9	33-103218	Drain Cap	1
10	33-103219	Drain Cap Tether	1
11	33-103220	Drain Cap Gasket	1
12	33-103718	24 Gallon Lawn Sprayer Tank	1
13	3EL12HB	1/2" HB x 1/2" HB Elbow Fitting	1
14	EF2200-QA	Quick Attach 2.2 GPM Everflo Pump	1
15	GC-100-KIT	Gun Clip Kit	1
16	RTS2.0-14.125	Hose Strap	1
17	34-140158	Pressure Regulator Assembly	1
18	SG-2218-38-RUB15	Deluxe Spray Gun Assembly	1

36 GALLON TRAILER FRAME BREAKDOWN

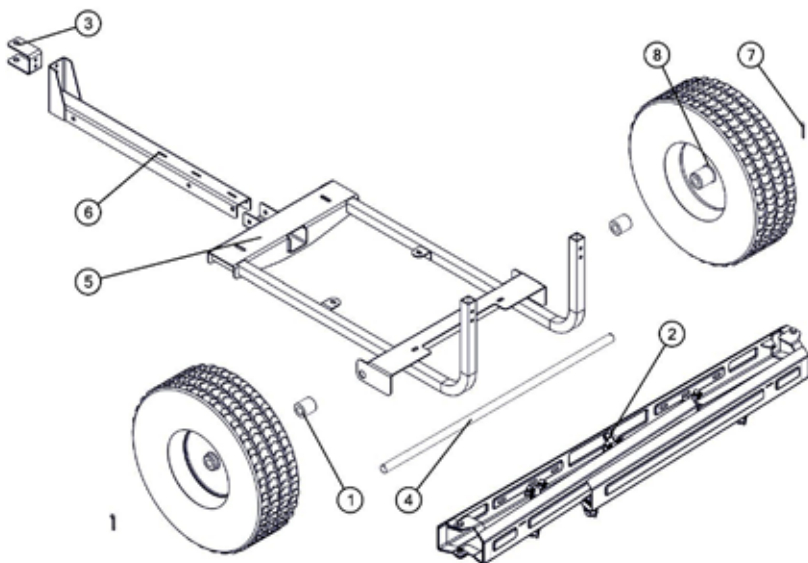

ID	Part Number	Description	Qty
1	075-8-00P	Wheel Spacer	2
2	34-140183	620 Boom Assembly	1
3	31-100519	Tongue Bracket	1
4	31-100520	Axle	1
5	32-100140	Frame	1
6	32-100141	Tongue	1
7	33-100091	Cotter Pin	2
8	TWA16X6.50-8-34	16" Wheel Assembly	2

36 GALLON TRAILER TANK BREAKDOWN

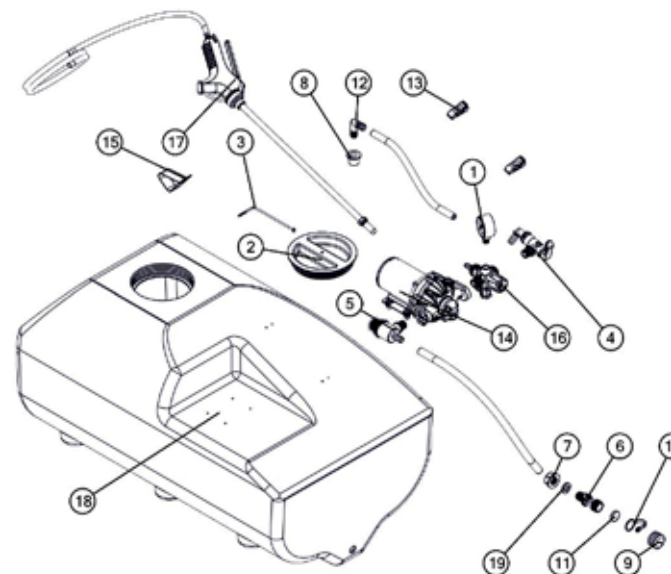

ID	Part Number	Description	Qty
1	1124DAB100	0-100 PSI Pressure Gauge	1
2	31-100340	Recessed Tank Lid	1
3	31-100341	Tank Lid Tether	1
4	34-140161	Boom Shut-Off Valve	1
5	34-140164	Inline Strainer	1
6	31-400012	Inlet/Drain Fitting	1
7	31-400013	Inlet/Drain Fitting Nut	1
8	33-100098	Top Hat Grommet	1
9	33-103218	Drain Cap	1
10	33-103219	Drain Cap Tether	1
11	33-103220	Drain Cap Gasket	1
12	3EL12HB	1/2" HB x 1/2" HB Elbow Fitting	1
13	GC-100-KIT	Gun Clip Kit	1
14	EF3000-QA	Quick Attach 3.0 GPM Everflo Pump	1
15	RTS2.0-14.125	Hose Strap	1
16	34-140158	Pressure Regulator Assembly	1
17	SG-2218-38-RUB15	Deluxe Spray Gun Assembly	1
18	33-103719	36 Gallon Sprayer Tank	1
19	W406V	Vinyl Washer	1

PLEASE FOLLOW ALL WARNINGS IN THIS MANUAL, FAILURE TO DO SO COULD RESULT IN PROPERTY DAMAGE & INJURY.



800.825.5397

MANUAL: 12V2436T-M