

LITTLE WONDER

PRO EDGER

6232-00-01
4 HP HONDA

6033-00-01
3.5 HP BRIGGS



MAN 4169184
Rev B 03-2018
Original Language Instructions

Parts and Operator Manual for
LITTLE WONDER Pro Edger

PARTS / OPERATOR'S MANUAL

CALIFORNIA

Proposition 65 Warning

Diesel engine exhaust and some of its constituents are known to the State of California to cause cancer, birth defects and other reproductive harm.

⚠ WARNING

The engine exhaust from this product contains chemicals known to the State of California to cause cancer, birth defects or other reproductive harm.

CALIFORNIA

Proposition 65 Warning

Battery posts, terminals, wiring insulation, and related accessories contain lead and lead compounds, chemicals known to the State of California to cause cancer and birth defects or other reproductive harm.

WASH HANDS AFTER HANDLING.

IMPORTANT MESSAGE

Thank you for purchasing this Little Wonder product. You have purchased a world class product, one of the best designed and built anywhere.

This machine comes with an Operation and Safety Manual, Parts and Service Manual, and Engine Manual. The useful life and good service you receive from this machine depends to a large extent on how well you read and understand these manuals. Treat your machine properly, lubricate and adjust it as instructed, and it will give you many years of reliable service.

Your safe use of this Little Wonder product is one of our prime design objectives. Many safety features are built in, but we also rely on your good sense and care to achieve accident-free operation. For best protection, study the manuals thoroughly. Learn the proper operation of all controls. Observe all safety precautions. Follow all instructions and warnings completely. Do not remove or defeat any safety features. Make sure those who operate this machine are as well informed and careful in its use as you are.

See a Little Wonder dealer for any service or parts needed. Little Wonder service ensures that you continue to receive the best results possible from Little Wonder products. You can trust Little Wonder replacement parts because they are manufactured with the same high precision and quality as the original parts.

Little Wonder designs and builds its equipment to serve many years in a safe and productive manner. For longest life, use this machine only as directed in the manuals, keep it in good repair and follow safety warnings and instructions. You'll always be glad you did.

LITTLE WONDER
SCHILLER GROUNDS CARE, INC.
1028 STREET ROAD, P.O. BOX 38
SOUTHAMPTON, PA 18966

TABLE OF CONTENTS	FIGURES	PAGE
SAFETY.....		4-8
SET UP INSTRUCTIONS.....		9
CONTROLS.....		10
OPERATION.....		11
MAINTENANCE		12
STORAGE		13
TROUBLESHOOTING		14
PARTS SECTION.....		15
HANDLE ASSY.....	FIGURE 1	16, 17
BLADE / DRIVE ASSY	FIGURE 2	18, 19
MAIN FRAME ASSY.....	FIGURE 3	20, 21
WARRANTY		BACK COVER



This Manual is part of the machine. Suppliers of both new and second-hand machines must make sure that this manual is provided with the machine.

NOTICE !!!

Unauthorized modifications may present **extreme** safety hazards to operators and bystanders and could also result in product damage.

Schiller Grounds Care, Inc. strongly warns against, rejects and disclaims any modifications, add-on accessories or product alterations that are not designed, developed, tested and approved by Schiller Grounds Care, Inc. Engineering Department. Any Schiller Grounds Care, Inc. product that is altered, modified or changed in any manner not specifically authorized after original manufacture-including the addition of "after-market" accessories or component parts not specifically approved by Schiller Grounds Care, Inc. will result in the Schiller Grounds Care, Inc. Warranty being voided.

Any and all liability for personal injury and/or property damage caused by any unauthorized modifications, add-on accessories or products not approved by Schiller Grounds Care, Inc. will be considered the responsibility of the individual(s) or company designing and/or making such changes. Schiller Grounds Care, Inc. will vigorously pursue full indemnification and costs from any party responsible for such unauthorized post-manufacture modifications and/or accessories should personal injury and/or property damage result.



This symbol means:
ATTENTION!
BECOME ALERT!

Your safety and the safety of others is involved.

Signal word definitions:

The signal words below are used to identify levels of hazard seriousness. These words appear in this manual and on the safety labels attached to Schiller Grounds Care, Inc. machines. For your safety and the safety of others, read and follow the information given with these signal words and/or the symbol shown above.

⚠ DANGER

DANGER indicates an imminently hazardous situation which, if not avoided, **WILL** result in death or serious injury.

⚠ WARNING

WARNING indicates a potentially hazardous situation which, if not avoided, **COULD** result in death or serious injury.

⚠ CAUTION

CAUTION indicates a potentially hazardous situation which, if not avoided, **MAY** result in minor or moderate injury. It may also be used to alert against unsafe practices or property damage.

CAUTION

CAUTION used without the safety alert symbol indicates a potentially hazardous situation which, if not avoided, **MAY** result in property damage.

Schiller Grounds Care, Inc.

1028 Street Road
Southampton, PA 18966 U.S.A
Phone: 215-357-5110
Fax: 215-357-8045

MODEL NUMBER

SERIAL NUMBER

MODEL NUMBER: This number appears on sales literature, technical manuals and price lists.

SERIAL NUMBER: This number appears only on your unit. It contains the model number followed consecutively by the serial number. Use this number when ordering parts or seeking warranty information.

OPERATOR PREPARATION & TRAINING

READ THE OPERATION & SAFETY MANUAL

- If an operator or mechanic cannot read English, it is the owner's responsibility to explain this material to them. If any portion of this material is unclear, contact your factory representative for clarification.
- Become familiar with the safe operation of the equipment, operator controls and safety signs. Be prepared to stop the engine quickly in an emergency. Do not operate or allow another person to operate this machine if there are any questions about safety.
- All operators and mechanics should be trained. The owner is responsible for training the users.
- Wear appropriate clothing, including safety goggles or safety glasses with side shields when operating. Wear substantial footwear and long pants. Do not operate barefoot or wearing open sandals. Long hair, loose clothing or jewelry may get tangled in moving parts.
- Wear appropriate hearing protection.
- Never allow children, unskilled or improperly trained people to operate this equipment. Local regulations can restrict the age of the operator.
- Do not put hands or feet near or under rotating parts.
- Never pick up or carry the unit while the engine is running.
- Keep warning labels and this operator's manual legible and intact. Replacement labels and manuals are available from the factory.
- Do not operate machine while under the influence of drugs or alcohol, or any other condition of impairment.
- The owner/user can prevent and is responsible for accidents or injuries occurring to themselves, other people, or property.



SITE PREPARATION & CIRCUMSTANCES

- Evaluate the terrain to determine how to safely perform the job. Only use accessories and attachments approved by the manufacturer.
- Clear the area of objects such as rocks, toys, wire or any other debris that may be thrown or get tangled in the blade.
- Be sure the area is clear of pets and people, especially young children. Never assume they will remain where you last saw them. Stop the machine if any enter the area.
- Only use in daylight or in good artificial light.
- Keep in mind that the operator or user is responsible for accidents or hazards occurring to other people or their property.

MULTIPLE OPERATORS

- Keep a safe distance between operators when working together.

MACHINE PREPARATION

- Read engine manual.
- Do not tamper with or defeat safety devices. Keep guards, shields and interlock safety devices in place and in proper working condition. They are for your protection.
- Keep all fasteners such as nuts, bolts, and pins well secured.
- Visually inspect blade and the assembly for wear or damage. Replace worn or damaged parts.
- Verify that machine and attachments, if any, are in good operating condition.
- Do not engage blade until ready to use.

OPERATING SAFELY**IN GENERAL**

- Use extra care when loading or unloading the machine into a trailer or truck.
- Never operate without guards, plates, or other safety protective devices in place.
- Do not run the engine in an enclosed area where dangerous carbon monoxide fumes can collect.
- Never leave a machine unattended. Turn off blade and stop engine before leaving the machine.
- Use extreme caution when pulling machine towards you.
- Stop operation if someone approaches.

STARTING

- Start according to instructions in this manual or on the machine.
- Before attempting to start the engine, make sure the blade is disengaged.
- When starting the engine, make sure hands and feet are clear of the blade.
- Do not engage blade at full throttle. Throttle to idle or lowest possible engine speed.
- Do not change engine governor settings or overspeed the engine. Operating the engine at excessive speed can increase the hazard of personal injury.

**INTERRUPTING OPERATION**

Before leaving the operator's position shut off engine.

- Stop the engine, disengage the blade, and wait until the blade stops rotating:
 - before refueling.
 - before making height adjustment unless the adjustment can be made from the operator's position.
- Stop the engine, disengage the blade, and disconnect the spark plug wire:
 - before clearing blockages or unclogging;
 - before checking, cleaning or working on the machine;
 - after striking a foreign object. Inspect the machine for damage and have repairs made as needed before restarting;
 - if the machine begins to vibrate abnormally: shut off machine immediately. Inspect and have repairs made as needed before restarting;
 - except for repairs or adjustments as specifically noted, such as for carburetor adjustment, where the engine must be running. Keep hands and feet clear of moving parts in these circumstances.
- Allow the blade to come to a complete stop when stopping operation to clear blockages, unclog, inspect the machine, do maintenance or repair.
- Reduce the throttle setting during engine shutdown and, if the engine is provided with a shutoff valve, turn the fuel off at the conclusion of operation

MAINTENANCE SAFETY

IN GENERAL

- Maintain machine according to manufacturer's schedule and instructions for maximum safety and best results.
- Park machine on level ground.
- Never allow untrained personnel to service machine.
- Guards should only be removed by a qualified technician for maintenance or service. Replace when work is completed.
- Adjust or repair only after the engine has been stopped and the blade has stopped moving.
- Disconnect spark plug wire before doing any maintenance.
- Replace parts if worn, damaged or faulty. For best results, always replace with parts recommended by the manufacturer.
- Do not dismantle the machine without releasing or restraining forces which may cause parts to move suddenly.
- Provide adequate support, e.g. jack stands for lifted machine or parts if working beneath.
- Do not put hands or feet near or under rotating parts.
- Clean up spilled oil or fuel thoroughly.
- Replace faulty mufflers.
- To reduce fire hazards, keep the engine, muffler, and fuel storage area free of grass, leaves, debris buildup or grease.
- Never attempt to make adjustments while the engine is running except for repairs or adjustments as specifically noted, such as for carburetor adjustment, where the engine must be running. Keep hands and feet clear of moving parts in these circumstances.

Blades

Do not straighten or weld blades. Replace damaged blades.

Fuel

- Gasoline (petrol) and diesel fuels are flammable; gasoline (petrol) vapors are explosive. Use extra care when handling.
- Store only in containers specifically designed for fuel.



- When refueling or checking fuel level:
 - Stop the engine and allow to cool;
 - Do not smoke;
 - Refuel outdoors only;
 - Use a funnel;
 - Do not overfill;
 - If fuel is spilled, do not attempt to start the engine until the spill is cleaned up and vapors have cleared.
- Replace caps on fuel containers and tanks securely.

Sparks from static electricity can start fires or cause explosions. Flowing fuel can generate static electricity. To prevent static electricity sparks:

- Keep containers electrically grounded. Do not fill containers in a vehicle or on a truck or trailer bed with a plastic liner. Fill containers on the ground away from the vehicle.
- When practical, remove petrol (gasoline) powered equipment from the truck or trailer and refuel it on the ground. If equipment must be refueled on the truck or trailer, refuel from a portable container rather than a dispenser nozzle.
- Keep the dispenser nozzle in contact with the rim of the fuel tank or container opening until fueling is complete. Do not use a nozzle lock-open device.
- If fuel is spilled on clothing change it immediately.

STORAGE SAFETY

- Stop the engine and allow to cool before storing.
- Drain the fuel tank outdoors only.
- Store fuel in an approved container in a cool, dry place.
- Keep the machine and fuel containers in a locked storage place to prevent tampering and to keep children from playing with them.
- Do not store the machine or fuel container near an open flame, spark, or appliance, such as a water heater, or a pilot light.
- Keep gasoline (petrol) storage area free of grass, leaves and excessive grease to reduce fire hazard.
- Clean grass and debris from cutting units, drives, mufflers and engine to help prevent fires.

WARNING LABELS

Warning labels are an important part of the safety system incorporated in this machine. Replace labels if damaged or illegible.

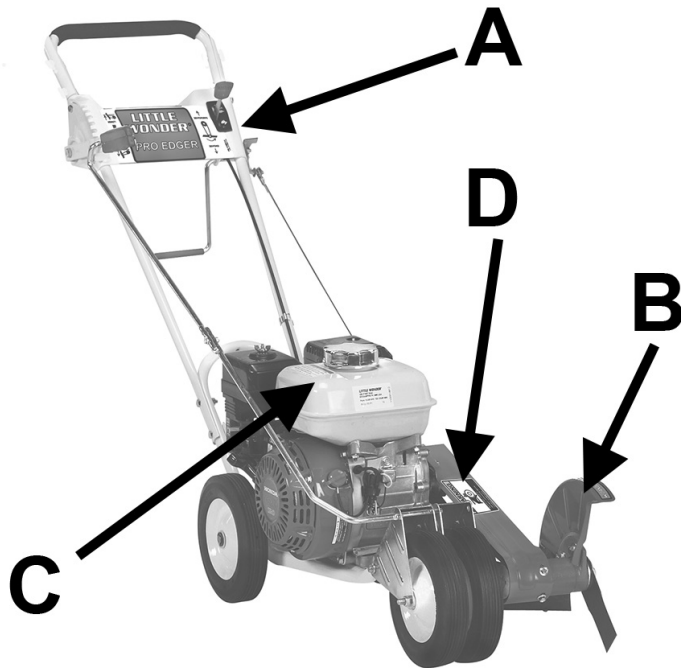

Key #B P/N 4169115

DANGER	-ROTATING BLADE	
	-KEEP HANDS and FEET AWAY	

Key #C P/N 211

CAUTION

- Use eye protection, rotating blade may throw objects.
- Read operator's manual before use.
- To reduce risk of fire, replace gasoline cap securely.
- Do not operate without guards in place.

Key #D P/N 4168760

WARNING

- ROTATING PARTS.
- DO NOT OPERATE WITH COVER REMOVED

4168760

Key #A P/N 4169114

	<p>BEFORE STARTING:</p> <ul style="list-style-type: none"> - Read and understand operator manual and labels. - Wear hearing and eye protection. - Replace labels and operator manual if lost or damaged. 	
WARNING		
LITTLE WONDER[®]		
PRO EDGER		
<p>↑ LOWER</p> <p>RAISE ↓</p>	<p>↑ DISENGAGE</p> <p>ENGAGE ↓</p>	<p>PN 4169114</p>

ASSEMBLY INSTRUCTIONS

Your Little Wonder Pro Edger requires a minimal amount of assembly prior to use. Use **Figures 1 & 3** in parts section for assembly.

1. Remove two nuts & bolts (P/N 472 & 144-1), holding handle supports (P/N 267 & 266) to lower handle (P/N 141-2).
2. Align upper handle (P/N 142-2) with lower handle (P/N 141-2) and replace the two nuts and bolts that were removed in step one.
3. Use two bolts & nuts (P/N 472 & 144-1) in the upper holes of the handles - now tighten all four bolts.
4. Use a #10-32 x 1 1/4 screw and lock nut (P/N 208 & 973) to connect the upper adjusting rod (P/N 155) to the lower adjusting rod (P/N 4163572).
5. Remove cotter pin and washer (P/N 156 & 163) from belt slackener lever (P/N 167-2) and place elongated loop of the draw bar (P/N 198) onto the belt slackener lever. Place washer back on and install cotter pin bending the legs once it is in place.
6. Remove the cotter pin (P/N 156) from the clevis pin (P/N 170) and slide the clevis pin out of its hole. Place the round hole of the link draw bar (P/N 198) between the two holes of the link belt slackener (P/N 169) and slide clevis pin back in place.
7. Replace cotter pin and bend the legs.
8. Rotate the mud flap (P/N 209) out from under the machine so that it is as far forward as possible without touching the brush while the paving cleaner is in its lowest position and the rubber flap is bent forward. Tighten from underneath.
5. Position the enclosed Blade Guard (P/N 129B) over the blade.
6. Align the holes in the blade guard with those on the cutter head. Secure with two hex head screws (P/N 129C), lock washers (P/N 129D), and flat washers (P/N 163).

THROTTLE INSTALLATION

Use **Figure 1** in parts section for assembly.

1. Remove the air filter cover from the engine.
2. Use a 10mm socket to loosen the throttle lever pivot nut.
3. Move the remote throttle lever all the way to slow (turtle) position. Move it 1/16" - 1/8" back towards the fast (rabbit) position.
4. Move the engine throttle lever to the slow position (push throttle lever to the front of the edger).
5. Remove the throttle cable retaining clamp and screw from the engine.
6. Insert the end of the throttle cable into the hole on the engine throttle lever.
7. Place the cable-retaining clamp over the cable, insert the screw in and pull back and tighten.
8. Replace the air filter cover.
9. The remote throttle lever should move from slow to fast and be approximately centered in its slot.
10. If the throttle feels tight, loosen the engine throttle lever pivot nut.
11. If the throttle does not stay where it is placed, tighten the remote throttle lever pivot nut (P/N 410).

BLADE INSTALLATION

Use **Figure 2** in parts section for assembly.

1. Place one blade washer (P/N 128) on the cutter head shaft, and up against the bearing (P/N 124). make sure the side with the step is against the bearing and the flat side of the washer is facing away from the bearing.
2. Slide the Blade (P/N 129) onto the cutter head shaft.
3. Place remaining blade washer (P/N 128) on the cutter head shaft. Make sure the flat side is against the blade and the side with the step is facing away from the blade.
4. Attach a flange nut (P/N 130) onto the shaft and tighten..

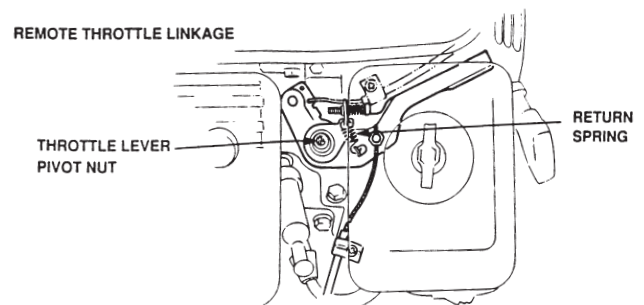

CONTROLS

BLADE HEIGHT ADJUSTMENT LEVER (A)

Rotate the lever away from the operator to raise the blade.
Rotate the lever toward the operator to lower the blade.

THROTTLE CONTROL (B)

Controls engine speed and controls speed of the blade.
Pushing the lever forward makes the engine speed go faster, while pulling the lever back slows down the speed of the engine

BELT SLACKENER LEVER (C)

Rotate the lever towards the operator to disengage the blade.
Rotate the lever away from the operator to engage the blade.

ENGINE START/STOP SWITCH (D)

Move to the "OFF" position to stop the engine.
Move to the "ON" position before starting the engine.

FUEL VALVE (F)

Move to the "OFF" position to shut off the fuel whenever transporting the machine by trailer or truck or during storage. Move to the "ON" position before starting the engine.

CHOKE (G)

Move to the "CHOKE" position to apply the choke.
Move to the "RUN" position to remove the choke.

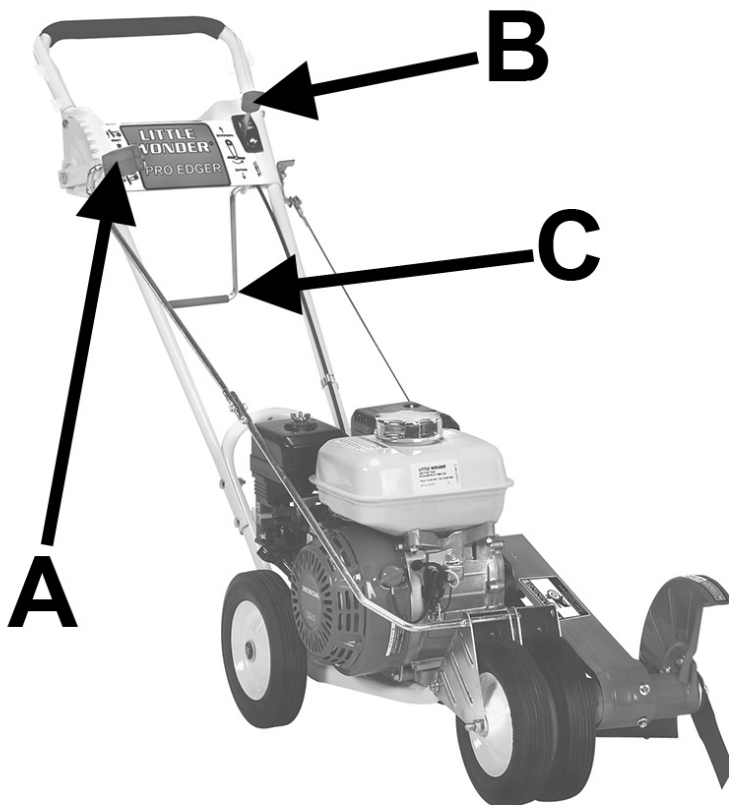
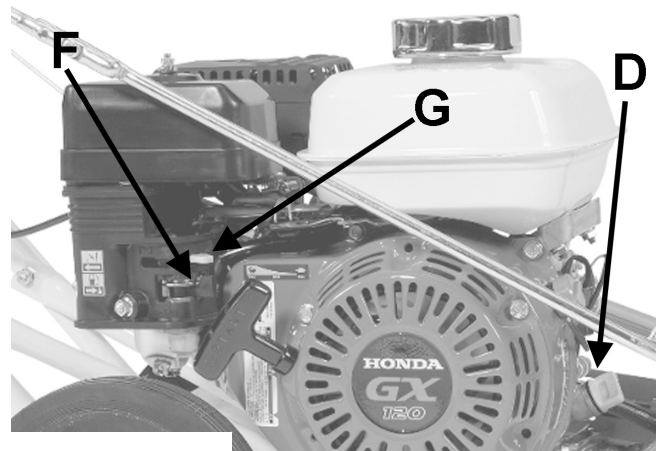

PRE-OPERATION CHECK LIST OWNER'S RESPONSIBILITY

- Review and follow all safety rules and safety decal instructions.
- Check that all safety decals are installed and in good condition. Replace if damaged.
- Check to make sure all shields and guards are properly installed and in good condition.
- Check that all hardware is properly installed and secured.
- Check to be sure engine is free of dirt and debris. Pay particular attention to the cooling fins, governor parts and muffler. Clean air intake screen. Check air cleaner; service as necessary.
- Check all lubrication points and grease as instructed in manual.
- Inspect area and remove stones, branches or other hard objects that might be thrown, causing injury or damage.
- Check that there are no exposed underground utilities in the work area.

FUELING-Gasoline (petrol) is extremely flammable and highly explosive under certain conditions. BE SURE to install fuel cap after fueling.

- Fill fuel tank with good quality, clean, unleaded regular petrol (gasoline) to the level recommended by the engine manufacturer.
- Use a funnel to avoid spilling.

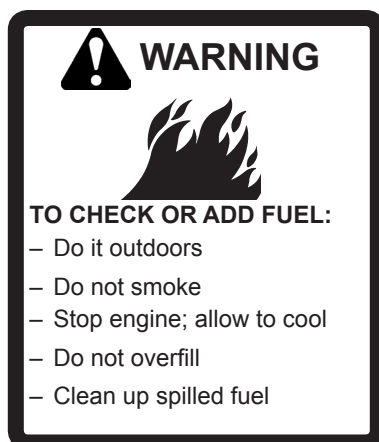

BEFORE STARTING THE ENGINE

- Read the operator manual and engine manual.
- Be familiar with all controls, how each functions and what each operates.
- Check the engine oil level and add if necessary. Follow the engine manufacturers recommendations per the engine manual supplied with the machine.
- Open the fuel valve.
- **Choke:** For cold starts, set the choke lever to the "CHOKE" position. For warm starts attempt to start without the choke first to avoid flooding. If the engine does not start then use the choke.

STARTING THE ENGINE

WARNING

ALL LITTLE WONDER EDGERS ARE SHIPPED WITHOUT OIL. WHEN FILLING OIL-USE SAE 30 OIL. REFER TO THE ENGINE MANUFACTURER'S INSTRUCTION MANUAL FOR PROPER ENGINE OPERATION INSTRUCTIONS.

1. For easier starting, remove belt tension by pulling up the belt slackener lever (P/N 167-2).
2. Prior to starting the engine, secure and hold the edger handle with your left hand.
3. Refer to your Engine Operator/Owner Manual for Engine Starting Instructions.
4. Once the engine starts, slowly move the choke to the run position and set the throttle control lever to desired speed.

NOTE: A warm engine requires less choking than a cold engine. The engine speed should be kept to the minimum consistent with the job at hand. Speeds higher than necessary will only cause undue wear and tear. A speed half-way between "fast" and "slow" is normally adequate. Tougher jobs may require higher speed.

STOPPING OPERATION

1. Pull throttle lever towards you to STOP position.
2. Turn engine switch to OFF position.

SETTING DEPTH OF BLADE

1. Place left hand on upper handle.
2. Grasp lever, P/N 228, with right hand and pull to the right, which disengages lever from ratchet segment on handle. Move lever forward or backward along ratchet segment and insert key on lever into notch on ratchet at the desired depth. Moving lever forward decreases depth, moving lever backward increases depth.

MAINTENANCE



WARNING

Stop the engine and remove spark plug wire before performing any maintenance.

When replacement parts are required, use genuine Little Wonder parts or parts with equivalent characteristics, including type, strength and material. Failure to do so may result in product malfunction and possible injury to the operator and/or bystanders.

Carbon monoxide present in the exhaust is an odorless and deadly gas. Never start or run the engine where exhaust fumes can collect. Provide enough fresh air to keep fumes from getting too strong.

Replace any warning decals that become illegible immediately.

DAILY MAINTENANCE

Hardware

- Tighten any hardware (nuts, bolts, etc) that are found loose.
- Replace any broken or missing hardware (nuts, bolts, cotter pins, etc.).
- Check to see that set screws on pulley are tight.

Engine

See engine manual for air cleaner service intervals and servicing procedure.

Oil

Check oil level daily. Top off as needed.

Change engine oil after the first 5 hours of operation. Then change as recommended by the engine manufacturer.

1. Remove the drain plug and drain oil while engine is warm.
2. Replace the drain plug, remove dipstick and fill with new oil. See engine manual for oil specifications.
3. Wipe off any oil on unit.
4. Start and run engine for 30 seconds. Stop engine.
5. Wait 30 seconds, then re-check oil level.
6. Top off as necessary. See engine manual for details.

Blade

Service:

Stop engine and remove spark plug wire before servicing blade.

- Check tightness of the blade nut prior to each use.

Guards

- Check condition of guards for damage or wear.
- Replace broken, worn, or damaged shield plates.

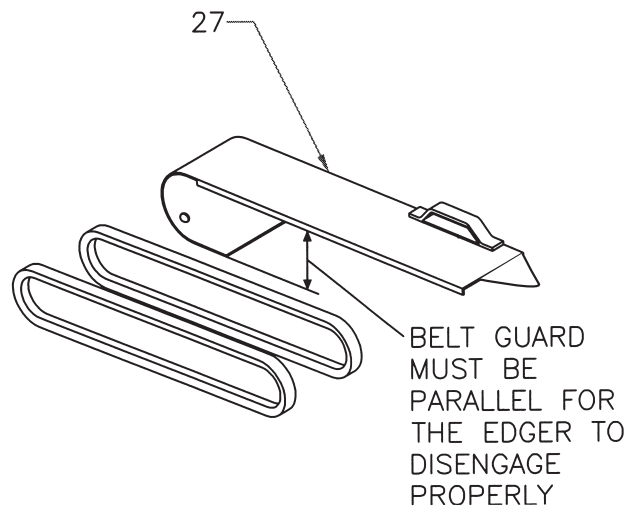

Belts

- Check condition of belts for damage or wear.
- Replace broken, worn, or damaged belts.

Belt Replacement

- Stop the engine and disconnect the spark plug wire before attempting to replace any belt.

Lubrication

- Lubricate cutter head shaft (P/N 131A), cutter head bracket (P/N 100C), and key (P/N 138) at slip rotation points every 8 hours.

STORAGE

To prevent possible explosion or ignition of vaporized fuel, do not store equipment with fuel in tank or carburetor in an enclosure with open flame (for example, a furnace or water heater pilot).

Before the equipment is put into storage for any period exceeding 30 days.

1. Drain all fuel from the fuel tank and fuel lines.
2. Start the engine and run until all the fuel is used from the carburetor float bowl and the engine stops.
3. While the engine is still warm, drain the crankcase oil and replace with the proper weight oil corresponding to the season the equipment will be next used.
4. Remove the spark plug and squirt a small amount of engine oil into the cylinder. Slowly pull the starter a few times to distribute oil in the cylinder and reinstall the spark plug.
5. Top off if necessary. See engine manual for details.

To put the equipment into service after an extended period of storage.

1. Check for loose parts and tighten if necessary.
2. Fill the fuel tank and then check the engine oil level.
3. Start the engine and check for fuel leaks. Repair any leaks before operating the unit.

TROUBLESHOOTING GUIDE

PROBLEM	POSSIBLE CAUSE	CORRECTIVE ACTION
A. Engine will not start.	<ol style="list-style-type: none"> 1. Out of gasoline. 2. Spark plug lead wire loose or disconnected. 3. Defective spark plug. 4. Throttle control lever not in proper position. 5. Engine flooded or flooding. 6. Stale or contaminated gasoline. 7. Engine switch off. 8. Oil level low. 	<ol style="list-style-type: none"> 1. Fill gasoline tank. 2. Reconnect spark plug lead wire. 3. Replace spark plug. 4. Move throttle control lever to start position. 5. Start engine with choke fully open. 6. Drain, clean tank and system and refill with fresh gasoline. 7. Turn engine switch to ON position. 8. Fill crankcase to proper oil level.
B. Loss of power, hard starting.	<ol style="list-style-type: none"> 1. Spark plug lead wire loose. 2. Defective spark plug. 3. Carburetor out of adjustment. 4. Air cleaner dirty. 5. Air vents clogged or plugged. 	<ol style="list-style-type: none"> 1. Tighten spark plug lead wire. 2. Replace spark plug. 3. Properly adjust carburetor. 4. Clean and service air cleaner. (See the engine Operation and Maintenance illustrations.) 5. Clean vent in gasoline tank cap and carburetor
C. Engine will not idle properly.	<ol style="list-style-type: none"> 1. Idle speed too slow. 2. Spark plug gap incorrect. 3. Air cleaner dirty. 	<ol style="list-style-type: none"> 1. Adjust carburetor idle speed or idle mixture. 2. Set spark plug gap; see your Engine Manual 3. Clean and service air cleaner. (See the engine Operation and Maintenance illustrations.)
D. Engine runs hot or overheats.	<ol style="list-style-type: none"> 1. Oil level low. 2. Engine cooling fins or baffles clogged with dirt and debris. 3. Carburetor out of adjustment 	<ol style="list-style-type: none"> 1. Fill crankcase to proper oil level. 2. Clean and remove obstructions. 3. Readjust carburetor.
E. Control mechanisms for depth blade will not function.	<ol style="list-style-type: none"> 1. Parts bent, distorted, worn out or missing. 	<ol style="list-style-type: none"> 1. Inspect control mechanism and repair or replace damaged, worn out, or missing components.

**PARTS
SECTION**

FIGURE 1

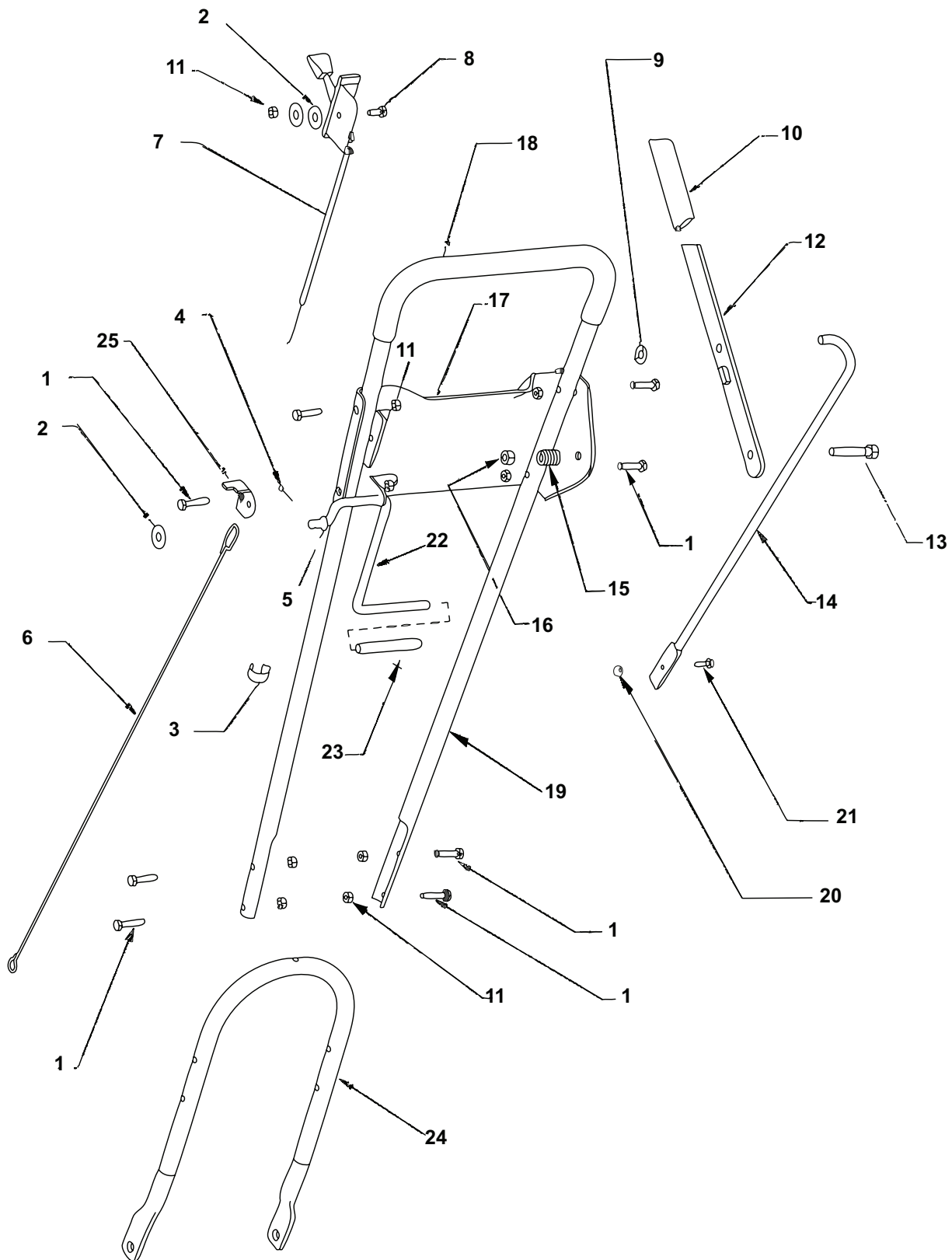

FIGURE 1

ITEM	PART NO.	DESCRIPTION	QTY
1	144-1	HEX HD CAP SCREW 1/4-20X1 1/4	12
2	163	WASHER - 3/8 ID	3
3	146B	THROTTLE CLIP	1
4	156	COTTER PIN	2
5	167A	SPEED NUT	1
6	198	DRAW ROD	1
7	271	THROTTLE ADJUST ASSEMBLY	1
8	410	HEX HEAD CAP SCREW 1/4-20 X 5/8	1
9	8-18	GRIP RING	1
10	227	GRIP - LEVER	1
11	472	LOCK NUT 1/4-20	9
12	228	LEVER	1
13	980	HEX HEAD CAP SCREW 3/8-16 X 2	1
14	155	ADJUSTING ROD UPPER	1
15	218	SPRING	1
16	102B	HEX NUT 3/8-16	2
17	226	HANDLE BRACE	1
18	236	GRIP - HANDLE	2
19	142-2	HANDLE UPPER	1
20	973	LOCK NUT #10-32	1
21	208	HEX HEAD CAP SCREW #10-32 X3/4	1
22	167-2	BELT SLACKENER LEVER	1
23	165A	GRIP	1
24	141-2	HANDLE-LOWER	1
25	219	BRACKET	1
26*	4169114	BRACE LABEL	1

*NOT ILLUSTRATED

FIGURE 2

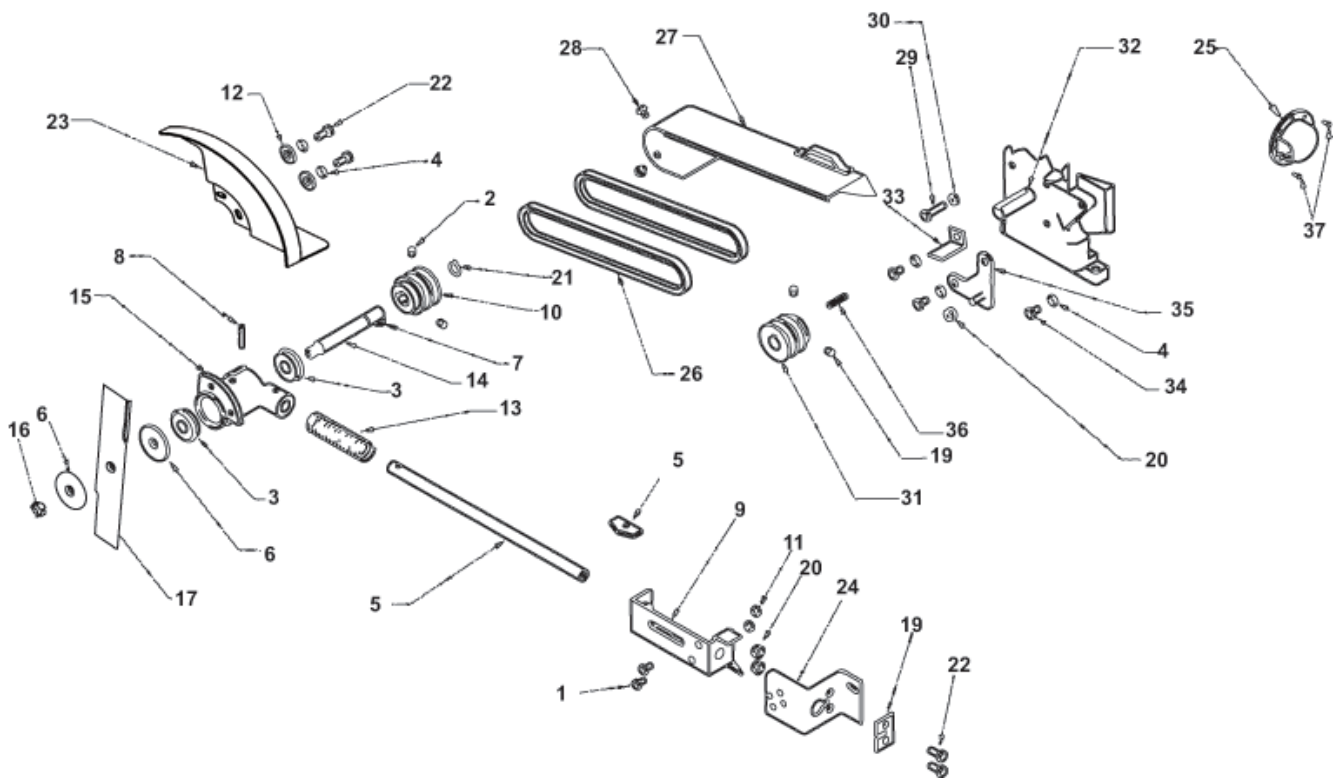

FIGURE 2

ITEM	PART NO.	DESCRIPTION	QTY
1	162B	HEX HEAD SCREW 1/4-20 X 1/2	2
2	118	SET SCREW 5/16-18 X 3/8	4
3	124	BEARING	2
4	129D	LOCK WASHER 5/16	5
5	131A	CUTTER HEAD SHAFT AND KEY	1
6	128	BLADE WASHER	2
7	121	WOODRUFF KEY #606	1
8	132	TENSION PIN 1/4 X 1 1/4	1
9	100-C	DECK BRACKET	1
10	220	PULLEY CUTTER HEAD	1
11	472	LOCK NUT 1/4-20	7
12	163	WASHER - 3/8 ID	2
13	134	SPRING	1
14	181	CUTTER BLADE SHAFT	1
15	126	CUTTER HEAD	1
16	130	NUT 1/2-20	1
17	129	BLADE	1
18*	211	CAUTION LABEL	1
19	192	GUIDE PLATE	1
20	114B	FLANGE NUT 5/16-18	10
21	122	RETAINING RING	1
22	129C	HEX HEAD SCREW 5/16-18 X 3/4	8
23	4163171	BLADE GUARD	1
24	191	GUIDE BRACKET	1
25	264	MUFFLER, EXHAUST DFLCTOR	1
26	177	V BELT	2
27	195P	BELT GUARD	1
28	140	HEX HEAD SCREW 1/4 - 20 X 3/8	2
29	196	HEX HEAD SCREW 5/16-24 X 1 1/4	1
30	197	JAM NUT 5/16-24	1
31	251	PULLEY - ENGINE	1
32	262	ENGINE-4HP HONDA USED ON 6232-00-01 ENGINE-3.5 HP BRIGGS	1
33	212	BRACKET	1
34	213	HEX HEAD SCREW 5/16 - 24 X 3/4	3
35	253	ADAPTER PLATE	1
36	117	KEY, PULLEY - 3/16" SQUARE	1
37	265	M4X8 PHILLIPS HEAD SLFTAPG	2
38*	4168760	WARNING LABEL BLADE	1
39*	4169115	WARNING LABEL	1

*NOT ILLUSTRATED

MAIN FRAME ASSEMBLY

PRO EDGER

FIGURE 3

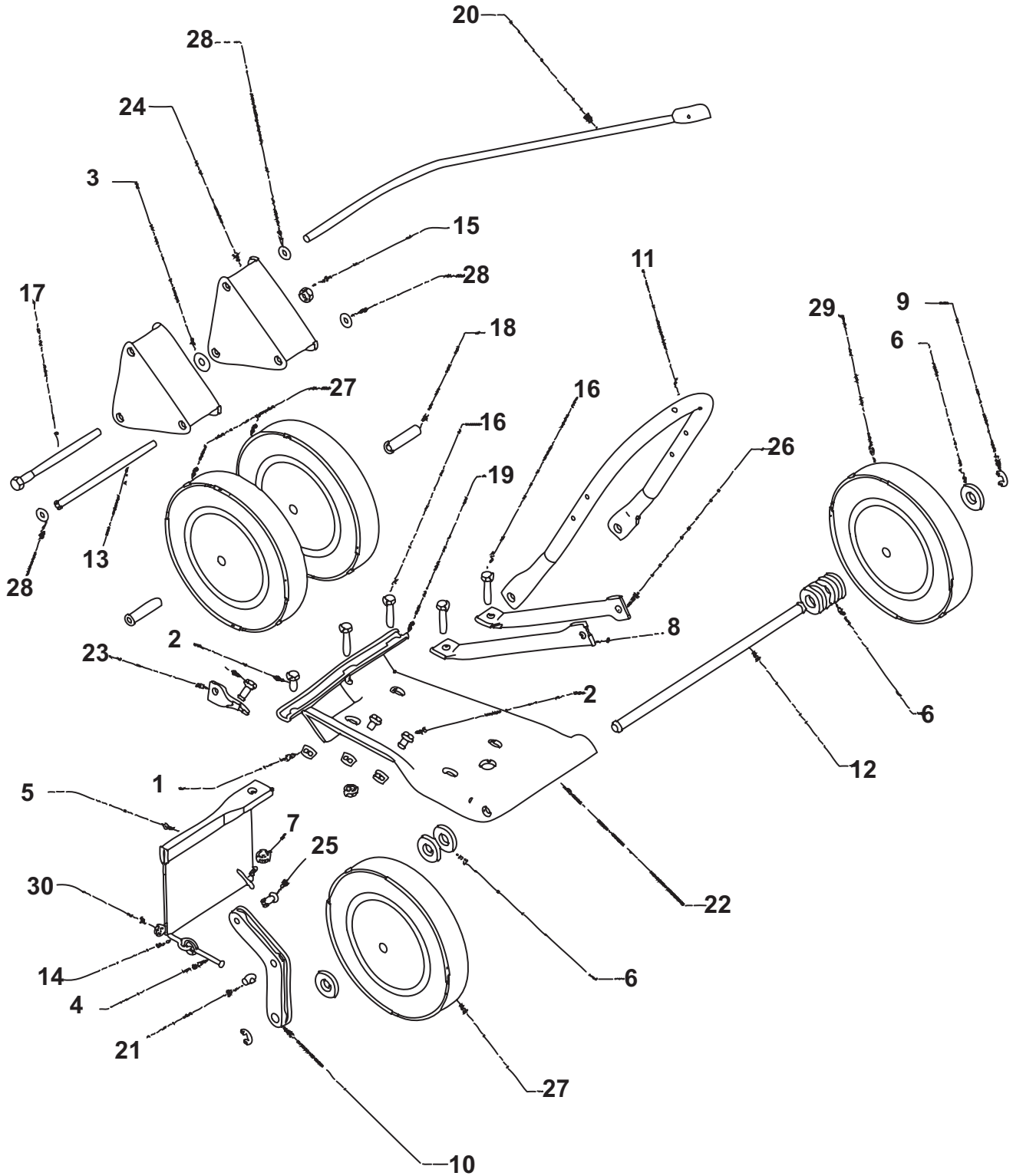

FIGURE 3

ITEM	PART NO.	DESCRIPTION	QTY
1	114B	FLANGE NUT 5/16-18	10
2	129C	HEX HD SCRW 5/16-18 X 3/4	8
3	163	WASHER - 3/8 ID	5
4	4163308	FORMED ROD .19 X 2.28	1
5	209	MUD FLAP	1
6	176	WASHER 1/2 ID	8
7	156	COTTER PIN	2
8	267	HANDLE SUPPORT - RH	2
9	103	RETAINING RING	2
10	169	LINK BELT SLACKENER	1
11	141-2	HANDLE-LOWER	1
12	184	AXLE	1
13	185	CLEVIS PIN	1
14	4163306	BOLT, EYE END 1/4-20X1.40	1
15	102B	HEX NUT 3/8-16	2
16	113	HEX HEAD SCREW 5/16-18X1 1/2	4
17	194	HEX HEAD SCREW 3/8-16X5 1/2	1
18	102C	SLEEVE	2
19	100D	DECK BRACKET SUPPORT	1
20	4163572	ADJUSTING ROD LOWER	1
21	171	CLEVIS PIN	1
22	100	DECK	1
23	193	FRONT WHEEL BRACKET	1
24	108	WHEEL HOUSING	2
25	170	CLEVIS PIN	1
26	266	HANDLE SUPPORT - LH	1
27	106	WHEEL	3
28	8-18	GRIP RING	3
29	107	OFFSET WHEEL	1
30	175B	NUT, 1/4-20	1

* NOT ILLUSTRATED



1 YEAR LIMITED SERVICE AND WARRANTY POLICY FOR LITTLE WONDER PRO EDGER

All LITTLE WONDER PRO EDGERS are warranted against defects in material and workmanship for a period of one (1) year from the date of purchase, under the following terms and conditions.

LITTLE WONDER will repair or replace, at its option, any part or parts of the product found to be defective in material or workmanship during the warranty period. Warranty repairs and replacements will be made without charge for parts or labor. All parts replaced under warranty will be considered as part of the original product, and any warranty on the replaced parts will expire coincident with the original product warranty. If you think your LITTLE WONDER PRO EDGER is defective in material or workmanship, you must return it to a registered dealer with a valid sales receipt or to our factory at 1028 Street Rd., Southampton, PA 18966. Transportation charges to ship your product to us or a registered dealer must be borne by you.

Engines for all gasoline powered products are warranted separately by the engine manufacturer. Therefore, there are no warranties made, expressed or implied, for engines for gasoline powered products by Little Wonder.

LITTLE WONDER assumes no responsibility in the event that the product was not assembled or used in compliance with any assembly, care, safety or operating instructions contained in the Owner's Manual or information accompanying the product. This limited warranty does not cover damages or defects due to normal wear and tear, lack of reasonable and proper maintenance, failure to follow operating instructions or Owner's Manual, misuse, lack of proper storage or accidents, nor does it cover routine maintenance parts and service. This limited warranty does not cover any defects due to repairs or alterations made to the product made by anyone other than LITTLE WONDER or its registered dealers.

You must maintain your LITTLE WONDER PRO EDGER by following the maintenance procedures described in the owner's manual. Such routine maintenance, whether performed by you or a registered dealer, is at your expense.

LITTLE WONDER MAKES NO EXPRESS OR IMPLIED WARRANTIES REPRESENTATIONS OR PROMISES EXCEPT THOSE CONTAINED HEREIN. THERE ARE NO OTHER WARRANTIES, INCLUDING WARRANTIES OF MERCHANTABILITY AND FITNESS FOR A PARTICULAR PURPOSE. ALL WARRANTIES OTHER THAN THE EXPRESS WARRANTY SET FORTH ABOVE ARE SPECIFICALLY DISCLAIMED. THE DURATION OF ANY IMPLIED WARRANTY, INCLUDING MERCHANTABILITY AND FITNESS FOR A PARTICULAR PURPOSE, IS LIMITED TO THE DURATION OF THIS WRITTEN LIMITED WARRANTY. LITTLE WONDER DISCLAIMS ALL LIABILITY FOR INDIRECT, INCIDENTAL AND/OR CONSEQUENTIAL DAMAGES IN CONNECTION WITH THE USE OF THE LITTLE WONDER PRO EDGER PRODUCTS COVERED BY THIS WARRANTY. SOME STATES DO NOT ALLOW LIMITATIONS ON HOW LONG AN IMPLIED WARRANTY LASTS AND/OR DO NOT ALLOW THE EXCLUSION OR LIMITATION OF INCIDENTAL OR CONSEQUENTIAL DAMAGES, SO THAT ABOVE LIMITATIONS AND EXCLUSIONS MAY NOT APPLY TO YOU. THIS WARRANTY GIVES YOU SPECIFIC LEGAL RIGHTS, AND YOU MAY ALSO HAVE OTHER RIGHTS WHICH VARY FROM STATE TO STATE.

LITTLE WONDER®

**SCHILLER GROUNDS CARE, INC.
1028 STREET ROAD, P.O. BOX 38
SOUTHAMPTON, PA 18966**

PHONE 877-596-6337 • FAX 215-357-8045

www.littlewonder.com