

PIT+PLUS® JR - PREMIUM SIMPLEX SYSTEMS

APPLICATIONS

Collection of sewage, drainage or seepage water

FEATURES

- Roto-molded polyethylene basin 24" x 24" (61 cm x 61 cm)
- Radial rib design for extra strength
- Molded inlet hub
- Molded anti-torque stops
- 360° molded handle
- Integrated anti-floatation collar
- Optional alarm versions
- Pre-assembled
- Functional and aesthetic finish cover
- Pump access cover
- Recessed discharge and vent location
- Independent recessed switch module
- Monolithic molded basin top
- Switch cord grips and locators for directional control
- 4/10 hp or 1/2 hp sewage pump and 1 hp grinder pump options available
- Max liquid temperature rating 135 °F (5 °C)



SERIES SPECIFICATIONS

Pit+Plus JR Sewage Pump Package System									
Item No.	Model No.	Vent	Discharge	Switch Type	Alarm	HP	Pump Item No.	Pump Model No.	Pump Voltage
509673	9JF2V2D	2"	2"	Float	-	4/10	509413	9SC-CIM	115
509674	9JF2V2DA1	2"	2"	Float	Indoor	4/10	509413	9SC-CIM	115
509679	9JF3V2D	3"	2"	Float	-	4/10	509413	9SC-CIM	115
509687	9JP2V2D	2"	2"	ECM	-	4/10	509413	9SC-CIM	115
511673	10JF2V2D	2"	2"	Float	-	1/2	511432	10SC-CIM	115
511676	10JF2V3D	2"	3"	Float	-	1/2	511435	10SC-CIM	115

Pit+Plus JR Grinder Pump Package System									
Item No.	Model No.	Vent	Discharge	Switch Type	Alarm	HP	Pump Item No.	Pump Model No.	Pump Voltage
509815	16JF2V2D	2"	2"	Float	-	1	509809	16G-M151-20	115

Note: Check valve not included.



PUMP OPTIONS



9SC - 4/10HP Sewage

10SC - 1/2HP Sewage

16G - 1HP Grinder

Basin Assemblies			
Item No.	Model No.	Vent	Discharge
513616	PPJ2V3D	2"	3"
513617	PPJ3V3D	3"	3"
513618	PPJ3V2D	3"	2"
513615	PPJ2V2D	2"	2"

Note: Pump and switch assembly not included.

Replacement Cover and Hardware Kits	
Item No.	Description
113388	Includes replacement bolts, washers, gasket, and wing bolts for finish cover
113389	Includes replacement main basin cover, bolts, washers, gasket, and wing bolts for finish cover

PACKAGE SYSTEMS

PIT+PLUS® JR - PREMIUM SIMPLEX SYSTEMS

ENGINEERING DATA

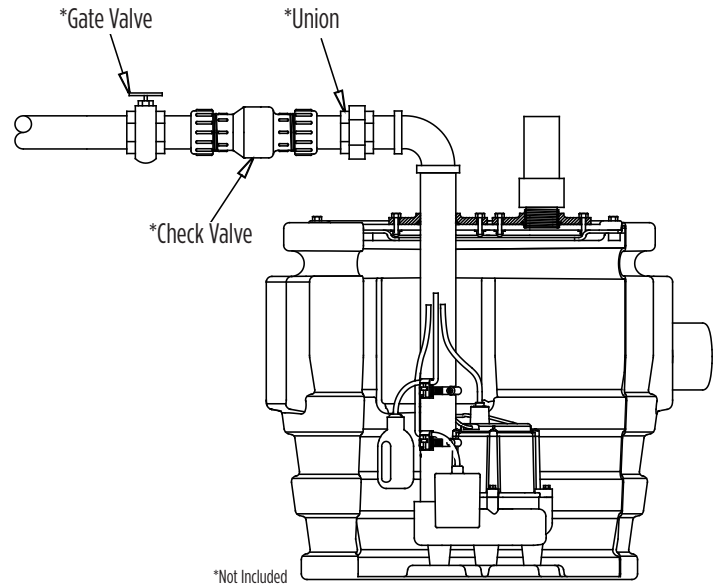
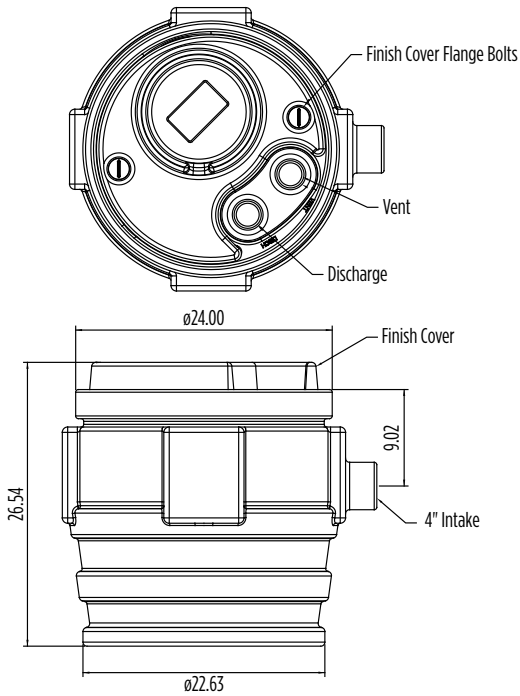

PERFORMANCE DATA

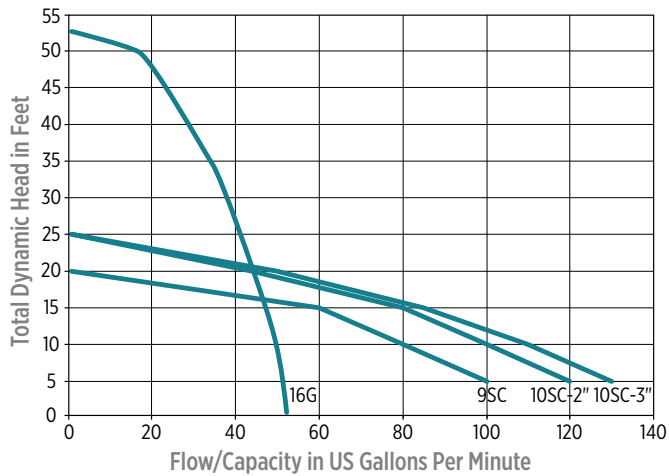

FLOAT AND ECM™ ASSEMBLIES



Float Assemblies		
Item No.	Model No.	Description
513633	PPJFNA	Junior Float Assy, No Alarm Hardware
513634	PPJFWA	Junior Float Assy, W/Alarm Hardware

ECM™ Assemblies		
Item No.	Model No.	Description
513637	PPJENA	Junior ECM Assy, No Alarm Hardware
513638	PPJEWA	Junior ECM Assy, W/Alarm Hardware

Note: Not for use with 1 hp grinder pump

