



SINGLE ZONE ART COOL™ PREMIER WALL MOUNTED ENGINEERING MANUAL

3/4, 1, 1-1/2, and 2 Tons

Models:
LA090HYV1
LA120HYV1
LA180HYV1
LA240HYV1



PROPRIETARY DATA NOTICE

This document, as well as all reports, illustrations, data, information, and other materials are the property of LG Electronics U.S.A., Inc., and are disclosed by LG Electronics U.S.A., Inc. only in confidence. This document is for design purposes only.

A summary list of safety precautions is on page 4.

For more technical materials such as submittals, catalogs, installation, owner's, and service manuals, visit www.lghvac.com.

About LG Electronics, Inc.

LG Electronics, Inc. is a global leader and technology innovator in consumer electronics, mobile communications, and home appliances. LG Electronics, Inc. comprises five business units—Home Entertainment, Mobile Communications, Air Conditioning, Business Solutions, and Home Appliance. LG is one of the world's leading producers of flat panel televisions, audio and video products, mobile handsets, air conditioners, and washing machines. LG's commercial air conditioning business unit was established in 1968 and has built its lineup of residential and commercial products to include VRF, Multi F, duct-free split systems, packaged terminal air conditioners (PTACs), and room air conditioners. In 2011, the air conditioning and energy solutions business unit grew to include LED lighting and solar products. For more information, visit www.lg.com.

Duct-Free Split Systems

LG HVAC systems offer a range of solutions that are cost efficient, quiet and attractive. Duct-Free Split systems are "split" into indoor and outdoor units, and provide a smart alternative to both central HVAC and window-mounted air conditioners. These inverter heat pump systems are available in a variety of configurations to suit different cooling and heating situations. Installation by a qualified HVAC contractor is safe and easy – little to no duct work or sheet metal is required.

Inverter Systems

LG Single Zone Art Cool™ Premier Wall Mounted air-source systems offer the opportunity to minimize ductwork in the same configuration. The system offers zoning without the need for zone damper systems. The LG Single Zone Art Cool™ Premier system's advanced controls provide exceptional building dehumidification and temperature control, and can rapidly adapt system operating parameters to the ever changing building load. The LG Single Zone Art Cool™ Premier system is easy to design, install, and maintain. The modular design allows occupants to control their environmental condition, providing individualized control of the setpoint temperature and allowing occupants to condition only the occupied zones.

Quality Commitment

LG is committed to the success of Duct-Free Split projects. We provide industry leading technical support during installation and commissioning. LG offers a variety of classes designed for installers and servicers to ensure that every system installation is completed successfully.





Classes are conducted at LG's training centers and in field locations at various times throughout the year and upon special request.



TABLE OF CONTENTS

Introduction.....	5	Performance Data.....	28-42
Architectural Appeal.....	6	Cooling Capacity.....	29
Product Features and Benefits	8	Heating Capacity.....	31
Unit Nomenclature.....	9	Maximum Heating Capacity.....	33
General Data	10-11	Air Flow and Temperature Distribution Graphs.....	35
Electrical Data.....	12	Equipment Selection Procedure	45
Functions, Controls, and Options.....	13	Building Ventilation Design Guide.....	46
Outdoor Unit Dimensions LAU090HYV1, LAU120HYV1	14	Placement Considerations	47-49
Outdoor Unit Dimensions LAU180HYV1, LAU240HYV1	15	Refrigerant Piping Design & Layout Best Practices	50-56
Outdoor Unit Center of Gravity / Corner Weight	16	Design Guideline Summary.....	51
Indoor Unit Dimensions LAN090HYV1, LAN120HYV1	17	Selecting Field-Supplied Copper Tubing	51
Indoor Unit Dimensions LAN180HYV1, LAN240HYV1	18	Refrigerant Piping System Layout.....	53
Acoustic Data.....	19-20	Electrical Connections.....	57
Refrigerant Flow Diagram.....	21-22	Mechanical Specifications	59
Wiring Diagrams.....	23-26	Acronyms.....	60
LAN090HYV1, LAN120HYV1.....	23		
LAN180HYV1, LAN240HYV1.....	24		
LAU090HYV1, LAU120HYV1.....	25		
LAU180HYV1, LAU240HYV1.....	26		
Accessories	27		

TABLE OF SYMBOLS

 DANGER	<i>This symbol indicates an imminently hazardous situation which, if not avoided, will result in death or serious injury.</i>
 WARNING	<i>This symbol indicates a potentially hazardous situation which, if not avoided, could result in death or serious injury.</i>
 CAUTION	<i>This symbol indicates a potentially hazardous situation which, if not avoided, may result in minor or moderate injury.</i>
Note	<i>This symbol indicates situations that may result in equipment or property damage accidents only.</i>
	<i>This symbol indicates an action should not be completed.</i>

INTRODUCTION

[“Architectural Appeal” on page 6](#)

ARCHITECTURAL APPEAL

Convergence of Technological Innovation with Flexibility and Style

Benefits of Single Zone Art Cool Premier Wall-Mounted System

- Available in 9,000, 12,000, 18,000, and 24,000 Btu/h
- Inverter technology
- All-season use - heat pump models for both cooling and heating capabilities
- Operating range for outdoor units of 14°F to 118°F (DB) in cooling and -13°F to 65°F (WB) in heating
- Operating range for indoor units of 53°F to 75°F (WB) in cooling and 60°F to 86°F (DB) in heating
- Quiet operation inside and outside
- Duct-free split system



Single Zone Art Cool Premier Wall-Mounted Systems

Choosing an LG Single-Zone Art Cool Premier Wall-Mounted product provides a system designer an edge to engineer a system with individual control, and design flexibility with advanced controls.

These single-zone systems are available in a nominal capacities of 3/4 to 2 tons. These are best suited for applications with zones that require heating or cooling, such as residential, and small business office buildings. Single-Zone Art Cool Premier Wall-Mounted outdoor and indoor units are available in 208–230V/60Hz/1Ph.



Adaptable and Flexible

Single-zone wall-mounted duct-free split systems allow cooling or heating for the entire residence or just a single room without the need for invasive ductwork. There is minimal renovation needed.

Long refrigerant piping lengths allow for extra design flexibility in indoor unit installation.

These units may be used for a number of residential or commercial environments such as:

- Older homes
- New home construction
- Office buildings
- Restaurants
- Hospitals / Medical facilities
- Schools
- Nursing homes
- Retail establishments
- House of worship

Inverter Technology

Inverter variable-speed duct-free split systems are measurably quieter and consume less energy than conventional air conditioners. The inverter compressor ramps up or down to match the required room capacity and maintain the comfort level. When the selected temperature is reached, the inverter compressor operates at low speed to maintain that comfort level, thereby using less energy.

PRODUCT DATA

- “Product Features and Benefits” on page 8**
- “Unit Nomenclature” on page 9**
- “General Data” on page 10**
- “Electrical Data” on page 12**
- “Functions, Controls, Options” on page 13**
- “Outdoor Unit Dimensions” on page 14**
- “Outdoor Unit Center of Gravity / Corner Weight” on page 16**
- “Indoor Unit Dimensions” on page 17**
- “Acoustic Data” on page 19**
- “Refrigerant Flow Diagram” on page 21**
- “Indoor Unit Wiring Diagram” on page 23**
- “Outdoor Unit Wiring Diagram” on page 25**
- “Accessories” on page 27**

PRODUCT FEATURES AND BENEFITS

Single Zone Art Cool™ Premier Wall Mount

Single zone systems are equipped with inverter components that offer superior load matching and long piping installation. The product works for optimizing power consumption in residential and small office buildings. Utilizing multiple indoor wall mount units each with custom temperature controls allow for precise temperature settings in each zone of the building. Single zone systems allow flexibility in interior design and complement any decor.

Low Sound Levels

When outdoor units run at full load, they have a quiet operating sound level. To promote a quiet, comfortable environment, the LG single zone system indoor units operate at sound levels as low as 25 dB(A) (17 dB(A) in sleep mode) and the outdoor units as low as 45 dB(A) at full load. All rotating components are soft-started by the controller using digitally controlled inverters, which reduce undesirable noise caused by fans and compressors cycling on and off.

Comfort Control at Its Best

Unlike traditional air conditioning control systems, which use thermostatic controls to maintain room temperatures, LG single zone inverter controls continuously vary the indoor unit fan speed and refrigerant flow.

LG single zone one-to-one systems continuously measure the room temperatures and adjust system operations accordingly to maintain set temperature.

The outdoor unit responds by varying the compressor speed and outdoor fan motors as needed to maintain system operating pressure. As a result, the single zone systems deliver targeted space temperature control.

Inverter Driven

The twin rotary compressors are optimized to maximize compressor efficiency, which reduces power consumption and monthly utility bills. This latest inverter technology allows single zone system outdoor units to vary the

compressor motor shaft speed to deliver an appropriate amount of cooling to the indoor unit. Precise refrigerant volume delivery translates into long periods with coil surface temperatures below dew point and minimizes compressor and fan component run time which may lead to lower utility usage.

Simplified Installation

Cooling and heating applications that use single zone systems simplify and reduce the mechanical and control system design time. The designer no longer has to be concerned with interconnecting chilled and condenser water piping, air-distribution duct systems, matching and selecting chillers, towers, pumps, coils, fans, air handlers, or Variable Air Volume (VAV) boxes.

Operating Range

Single zone systems have a nominal capacity range of 3/4 and 1 tons (depending on outdoor/indoor units).

Outdoor unit operating ranges for single zone systems:

Cooling: 14°F DB to 118°F DB

Heating: -13°F WB to 65°F WB

(Installing an optional Low Ambient Wind Baffle Kit will allow operation down to 0°F in cooling mode for these single zone systems.)

Compact Size

Single zone outdoor units have the following footprint:

LAU090HYV1, LAU120HYV1
(WxHxD [in.]) 30 5/16 x 21-1/2 x 11-5/16.

LAU180HYV1, LAU240HYV1
(WxHxD [in.]) 34-1/4 x 31-1/2 x 12-5/8.

Fin Design with GoldFin™ Coating

All single zone outdoor units are provided with large surface coils made of copper tubes with louvered aluminum fins designed to maximize unit operating efficiency over a wide range of ambient conditions.

Standard from the factory, every single zone outdoor unit coil fin surface is coated with LG's exclusive GoldFin™



anti-corrosive coating designed to prevent natural surface corrosion of the aluminum fins. This maintains heat transfer properties of the coil for an extended time.

A hydrophilic coating is applied to the outdoor unit coil fin surface over the GoldFin coating. This coating enhances the development of heavier water droplets gathering on the fin surface. As a result, the droplets roll off the fin surfaces, delaying the point when frost forms on the coil surface during heating operation. This coating also makes it possible to easily clean the outdoor unit coil using a mild soap.

Other Features

- Inverter variable speed compressor
- Jet Cool / Jet Heat
- Dehumidifying mode
- 3M™ Micro Protection Filter
- Auto Wind
- Auto restart
- Auto operation
- Self-cleaning indoor coil
- Condensate sensor connection
- Works with Smart AC
- Precision load matching
- Meets AHRI 210/240

UNIT NOMENCLATURE

Single Zone Wall Mount Indoor and Outdoor Units

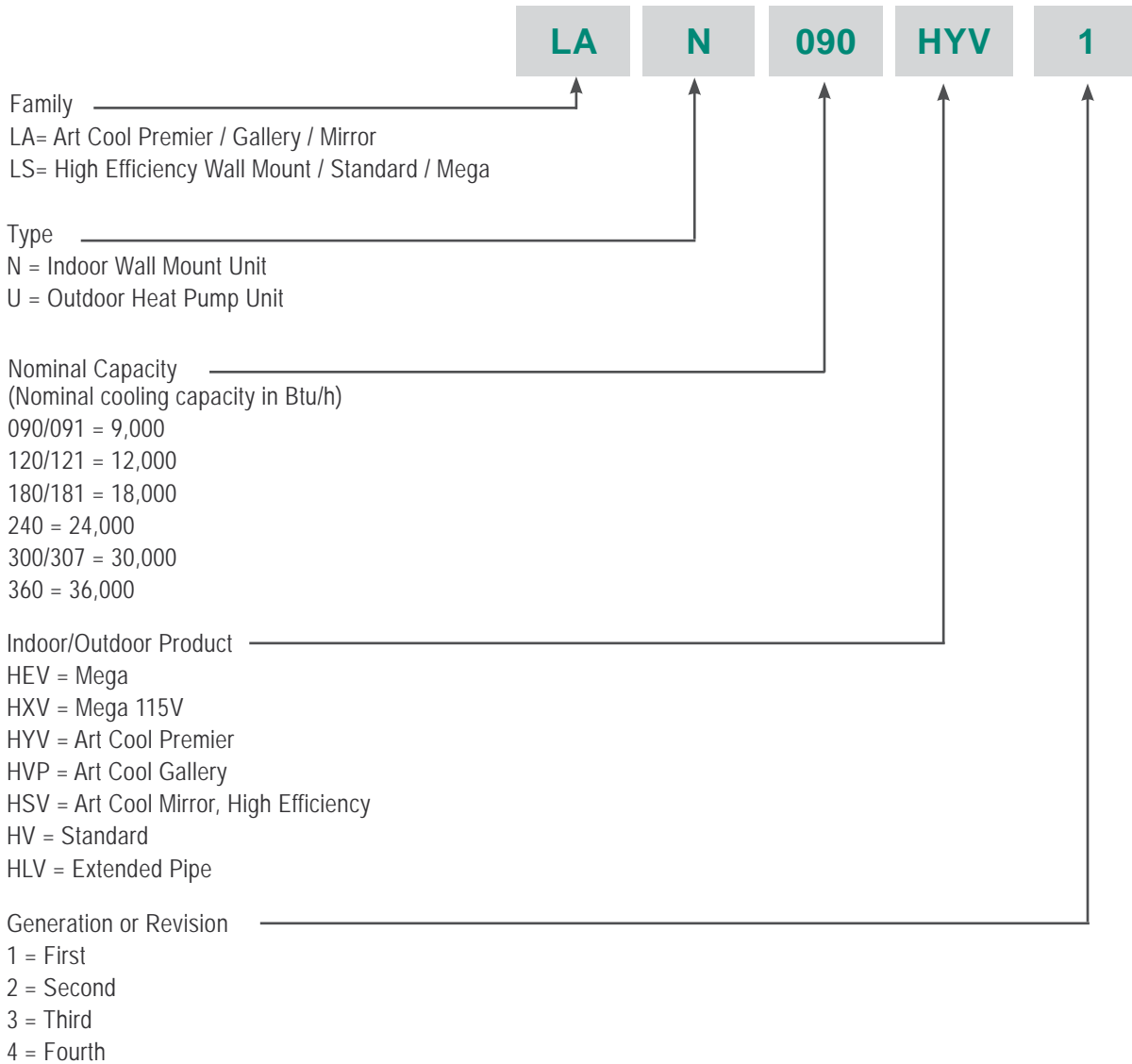





Product Data

GENERAL DATA

Art Cool Premier Pairing Table

The following table shows the available outdoor and indoor units, along with the factory provided controller.

Table 1: Single Zone Art Cool Premier Pairing Table

Outdoor Unit Model	Indoor Unit Model	Controller
LAU090HYV1 LAU120HYV1 	LAN090HYV1 LAN120HYV1 	AKB73835320 
LAU180HYV1 LAU240HYV1 	LAN180HYV1 LAN240HYV1 	AKB74835304 

GENERAL DATA

Table 2: Single Zone Art Cool Premier System Specifications.

System Model Number (IDU/ODU)	LA090HYV1 (LAN090HYV1/ LAU090HYV1)	LA120HYV1 (LAN120HYV1/ LAU120HYV1)	LA180HYV1 (LAN180HYV1/ LAU180HYV1)	LA240HYV1 (LAN240HYV1/ LAU240HYV1)
Cooling Capacity (Min/Rated/Max) (Btu/h)	1,023 ~ 9,000 ~ 12,966	1,023 ~ 11,000 ~ 13,785	3,070 ~ 18,200 ~ 29,515	3,070 ~ 22,000 ~ 30,000
Cooling Power Input ¹ (kW)	0.575	0.80	1.35	1.76
Heating Capacity (Min/Rated/Max) (Btu/h)	1,023 ~ 11,000 ~ 20,472	1,023 ~ 12,000 ~ 22,178	3,070 ~ 22,000 ~ 30,709	3,070 ~ 27,000 ~ 35,200
Heating Power Input ¹ (kW)	0.71	0.75	1.69	2.19
COP	4.54	4.68	3.81	3.61
<i>Maximum Heating Capacity (Btu/h)</i>				
Outdoor 17°F (WB)/Indoor 70°F (DB)	11,940 (109%)	14,650 (122%)	22,340 (102%)	27,410 (102%)
Outdoor 5°F (WB)/Indoor 70°F (DB)	11,220 (102%)	13,720 (114%)	19,300 (88%)	23,690 (88%)
Outdoor -13 °F (WB)/Indoor 70°F (DB)	7,920 (72%)	9,520 (79%)	14,060 (64%)	17,250 (64%)
EER	15.65	13.75	13.48	12.50
SEER	27.5	25.5	24	22
HSPF	12.0	12.0	12.5	12
Power Supply (V/Hz/Ø)	208-230/60/1			
<i>Outdoor Unit Operating Range²</i>				
Cooling (°F DB)	14 to 118			
Heating (°F WB)	-13 to 65			
<i>Indoor Unit Operating Range</i>				
Cooling (°F WB)	53 to 75			
Heating (°F DB)	60 to 86			
<i>Indoor Temperature Setting Range</i>				
Cooling (°F)	64 to 86			
Heating (°F)	60 to 86			
<i>Unit Data</i>				
Refrigerant Type ³	R410A			
Refrigerant Control	EEV			
IDU Sound Pressure ⁴ dB(A) (H/M/L/Sleep)	42/36/25/17	42/36/25/17	47/42/37/29	47/42/37/29
ODU Sound Pressure ⁴ dB(A)	45	45	57	57
<i>Unit Weight (lbs)</i>				
IDU (Net/Shipping)	24/30	24/30	34/38	34/38
ODU (Net/Shipping)	77/82	77/82	122/131	122/131
Power/Communication Cable ⁵ (No. x AWG)	4 x 18			
<i>Compressor</i>				
Compressor Type (Qty)	Twin Rotary (1)	Twin Rotary (1)	Twin Rotary (1)	Twin Rotary (1)
<i>Fan</i>				
IDU Type (Qty)	Cross Flow (1)			
ODU Type (Qty)	Propeller (1)			
Motor/Drive	Brushless Digitally Controlled/Direct			
<i>Airflow Rate</i>				
IDU Max/H/M/L (CFM)	547/494/417/283	547/494/417/283	742/565/424/318	777/565/424/318
ODU Max (CFM)	1,165	1,165	2,119	2,119
<i>Piping</i>				
Liquid Line (in, OD)	1/4	1/4	3/8	3/8
Vapor Line (in, OD)	3/8	3/8	5/8	5/8
Condensation Line (OD, ID)	27/32, 5/8	27/32, 5/8	27/32, 5/8	27/32, 5/8
Additional Refrigerant Charge (oz/ft)	0.22	0.22	0.38	0.38
Pipe Length ⁶ (Minimum/Maximum)(ft)	6.6/65.6	6.6/65.6	9.8/98.4	9.8/98.4
Piping Length ⁶ (no add'l refrigerant, ft)	41.0	41.0	24.6	24.6
Max Elevation Difference (ft)	32.8	32.8	65.6	65.6

EEV: Electronic Expansion Valve IDU: Indoor Unit ODU: Outdoor Unit

¹Power Input is rated at high speed.

²Optional Low Ambient Wind Baffle Kit allows operation down to 0°F in cooling mode.

³Take appropriate actions at the end of HVAC equipment life to recover, recycle, reclaim or destroy R410A refrigerant according to applicable regulations (40 CFR Part 82, Subpart F) under section 608 of CAA.

⁴Sound Pressure levels are tested in an anechoic chamber under ISO Standard 3745.

⁵All power wiring/communication cables are field supplied and are to be minimum 18 AWG, 4-conductor, stranded, shielded and must comply with applicable local and national codes.

⁶Piping lengths are equivalent.

This unit comes with a dry helium charge.

This data is rated 0 ft above sea level with 24.6 of refrigerant line per indoor unit and a 0 ft level difference outdoor and indoor units.

Cooling capacity rating obtained with air entering the indoor unit at 80°F dry bulb (DB) and 67°F wet bulb (WB) and outdoor ambient conditions of 95°F dry bulb (DB) and 75°F wet bulb (WB).

Heating capacity rating obtained with air entering the indoor unit at 70°F dry bulb (DB) and 59°F wet bulb (WB) and outdoor ambient conditions of 47°F dry bulb (DB) and 43°F wet bulb (WB).



ELECTRICAL DATA

Table 3: Single-Zone Art Cool Premier System Electrical Data Table.

Model Number	Nominal Tons	Compressor Qty.	Compressor (A) Cool/Heat	Fan Qty.	ODU Fan (A)	IDU Fan (A)	MCA(A)	MOP(A)
LA090HYV1	3/4	1	8.3/8.3	1	0.40	0.40	11.2	15
LA120HYV1	1	1	8.3/8.3	1	0.40	0.40	11.2	15
LA180HYV1	1-1/2	1	14.5/14.5	1	0.50	0.30	19.0	25
LA240HYV1	2	1	14.5/14.5	1	0.50	0.30	19.0	25

Voltage tolerance is ±10%.

Maximum allowable voltage unbalance is 2%.

MCA = Minimum Circuit Ampacity.

Maximum Overcurrent Protection (MOP) is calculated as follows: (Largest motor FLA x 2.25) + (Sum of other motor FLA) rounded down to the nearest standard fuse size.

FUNCTIONS, CONTROLS, OPTIONS

Table 4: Indoor Units—Functions, Controls and Options.

Indoor Unit Type		LA090HYV1	LA120HYV1	LA180HYV1	LA240HYV1
Airflow	Air supply outlet	1	1	1	1
	Airflow direction (left/right)	5 Steps	5 Steps	5 Steps	5 Steps
	Airflow direction (up/down)	6 Steps	6 Steps	6 Steps	6 Steps
	Auto swing (left/right)	√	√	√	√
	Auto swing (up/down)	√	√	√	√
	Airflow steps (fan/cool/heat)	6 / 6 / 6	6 / 6 / 6	6 / 6 / 6	6 / 6 / 6
	Auto swing	√	√	√	√
	Auto wind	√	√	√	√
	Jet-cool/heat	√ / √	√ / √	√ / √	√ / √
	Swirl wind	X	X	X	X
	One touch soft air	√	√	√	√
Air Purifying	Washable anti-fungal ¹	√	√	√	√
	Deodorizing filter	X	X	X	X
	Plasma ²	X	X	X	X
	Allergy free filter	X	X	X	X
	3M Micro Protection filter ²	√	√	√	√
Functions	Drain pump	X	X	X	X
	E.S.P. control	X	X	X	X
	Electric heater	X	X	X	X
	High ceiling	X	X	X	X
	Defrost	√	√	√	√
	Low ambient	√	√	√	√
	Hot start	√	√	√	√
	Self diagnostics	√	√	√	√
	Outdoor Unit Drain Pan Heater	√	√	√	√
	Soft dry (dehumidification)	√	√	√	√
	Auto changeover	√	√	√	√
	Auto clean (coil dry)	√	√	√	√
	Auto restart	√	√	√	√
	Child lock (applicable with wired controller)	0	0	0	0
	Forced operation	√	√	√	√
	Sleep mode	√	√	√	√
	Timer (24hr on/off)	√	√	√	√
	Weekly timer (applicable with wired controller)	0	0	0	0
	Two thermistor control (applicable with wired controller)	0	0	0	0
	Controllers	Wireless Remote Controller	√	√	√
Simple Controller with Mode Selection		0	0	0	0
Simple Controller without Mode Selection		0	0	0	0
LG Programmable Thermostat		0	0	0	0
Dry contact		0	0	0	0
Central control (LGAP)		X	X	X	X
Special Function Kit	PI 485	X	X	X	X
	Zone control	X	X	X	X
	CTIE	X	X	X	X
	Electro thermostat	X	X	X	X
	Wi-Fi Module (Option)	0	0	0	0
	Water level sensor connection (for optional AG-9300-LG)	0	0	0	0
Wind baffle kit	ZLABGP01A	ZLABGP01A	ZLABGP02A	ZLABGP02A	

¹Primary washable filters.

√ = Standard feature

• When Dry Contact Mode active, Wi-Fi Function can not be used.

²Secondary filters.

0 = Optional accessory (must be purchased separately)

• When changing from Wi-Fi mode to dry contact mode, normal operation resumes in approximately 3 minutes.

X = Not available



OUTDOOR UNIT DIMENSIONS

LAU090HYV1, LAU120HYV1

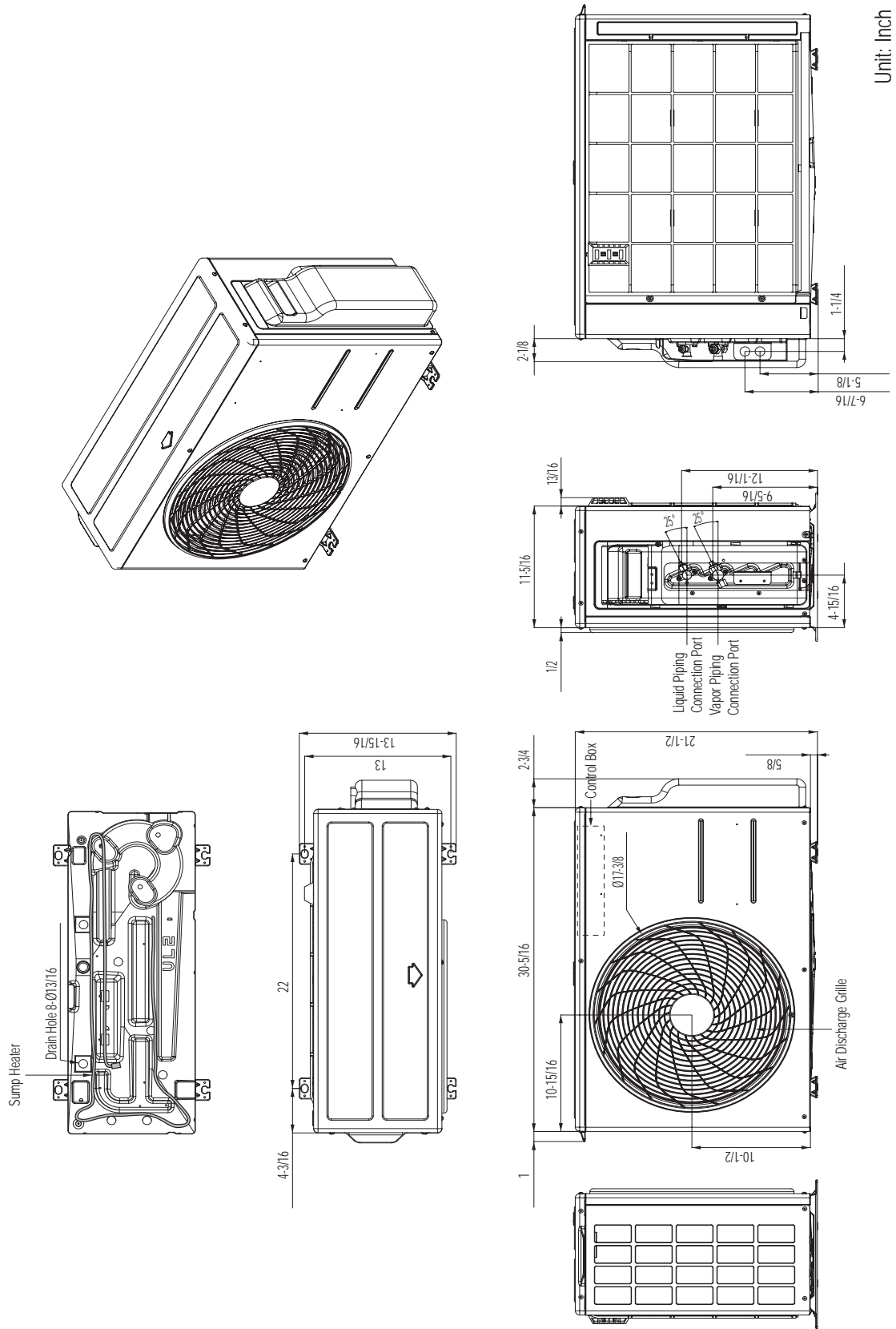

Unit: Inch

OUTDOOR UNIT DIMENSIONS

LAU180HYV1, LAU240HYV1

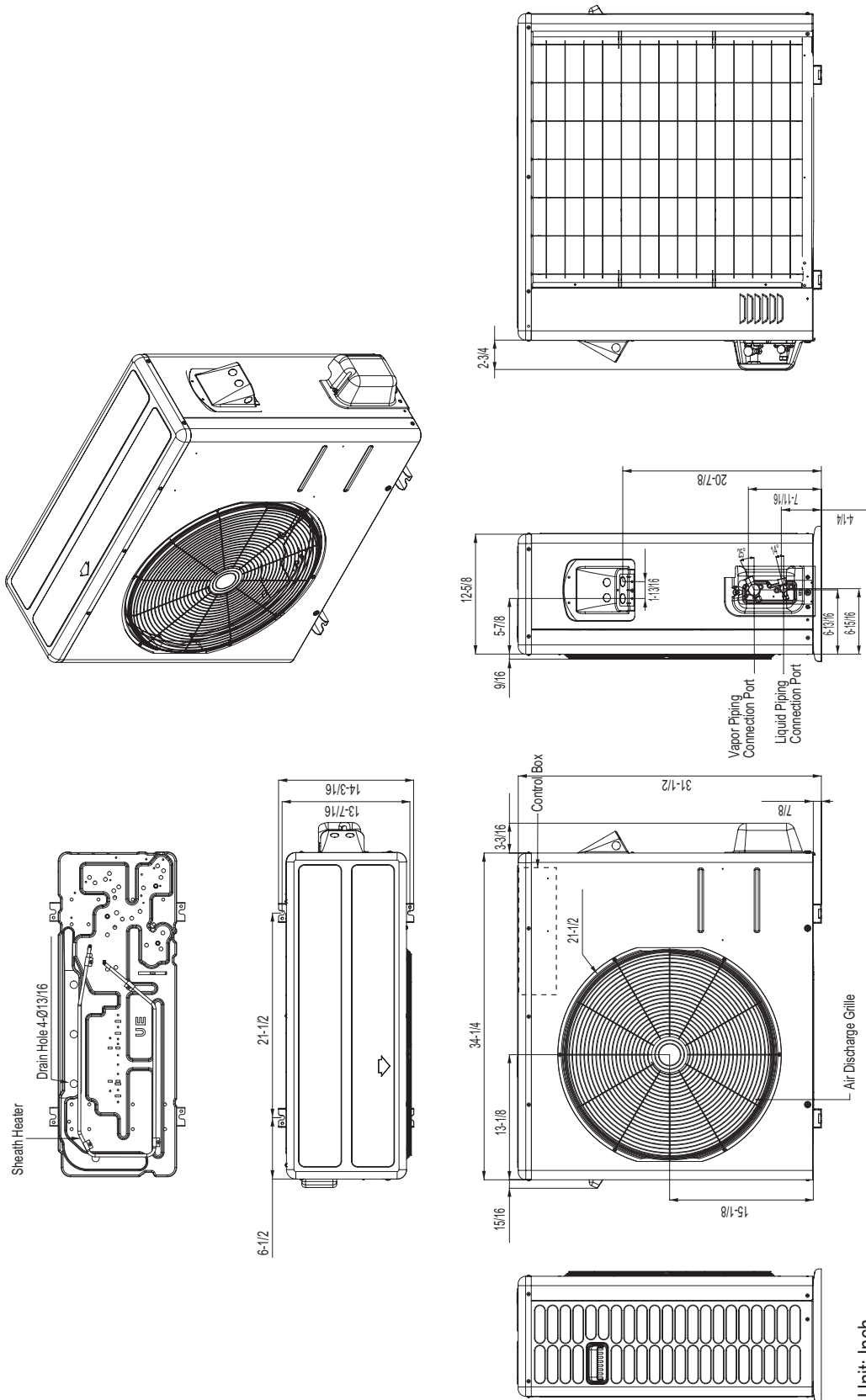

Unit: Inch

Product Data



OUTDOOR UNIT CENTER OF GRAVITY / CORNER WEIGHT

Figure 1: LAU090-240HYV1 Center of Gravity and Corner Weight Dimensions Diagram.

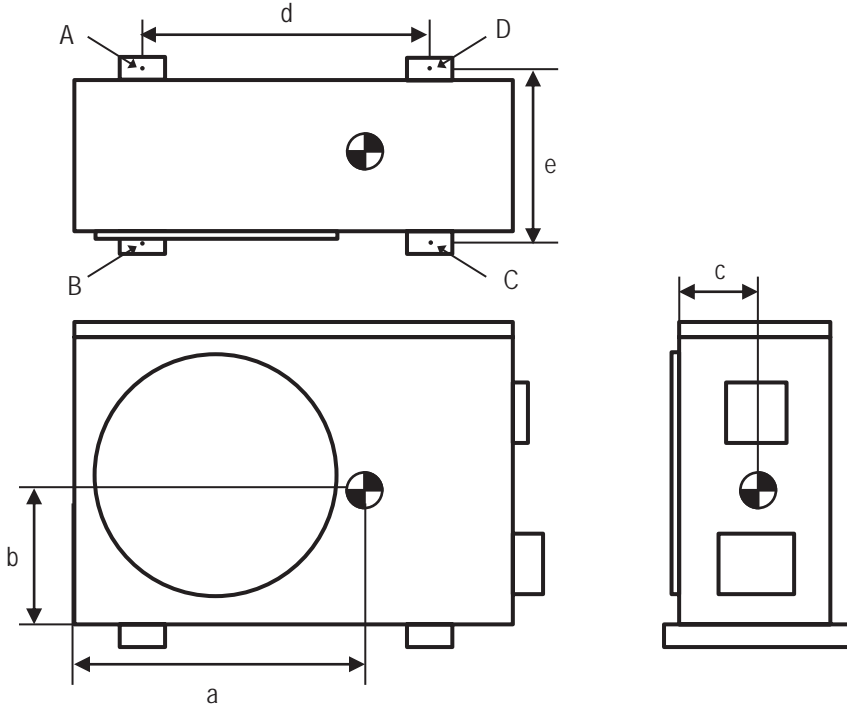
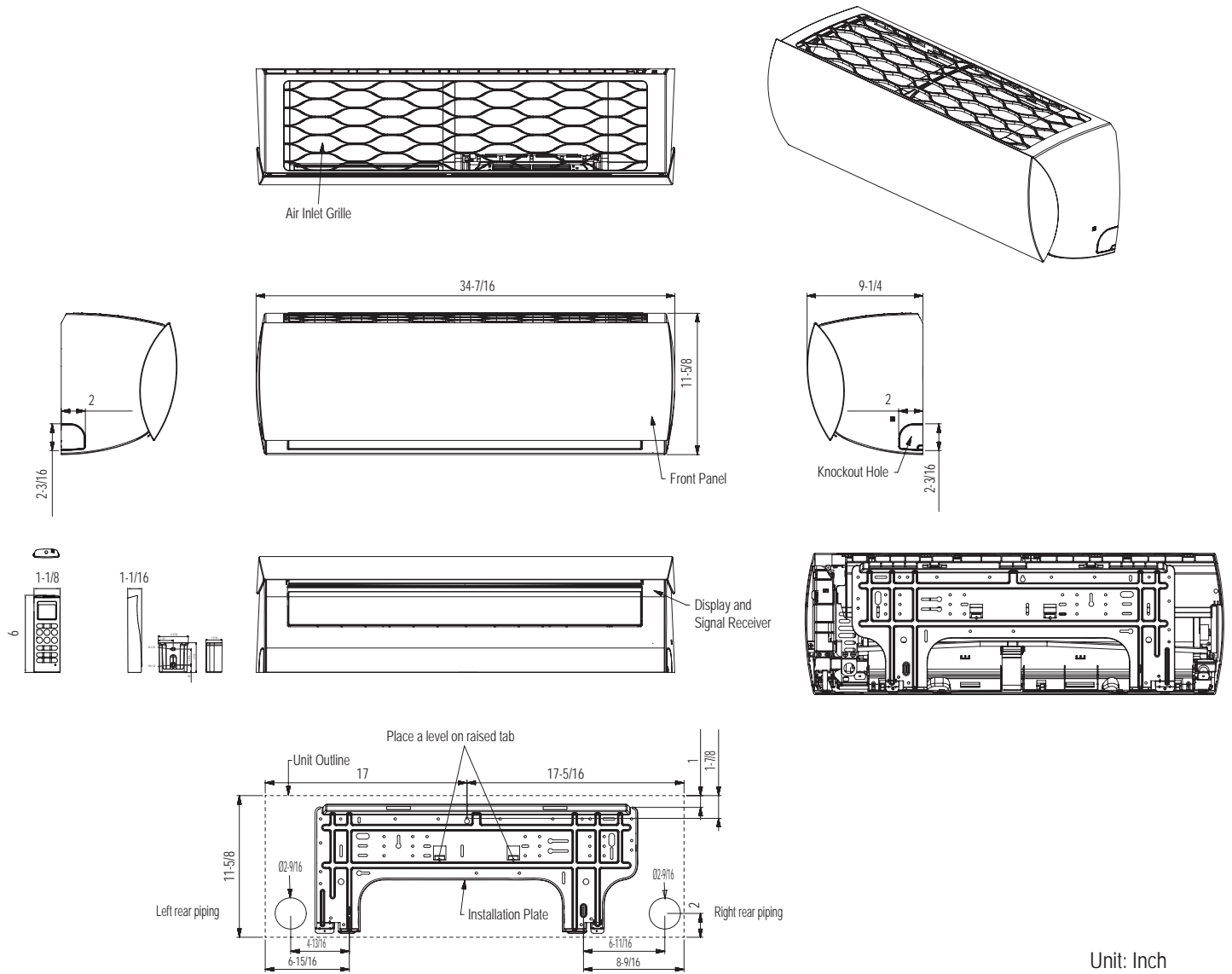

Table 5: Center of Gravity and Corner Weight Dimensions.

Model	Weight (lb.)		Center of Gravity (inch)			Leg (inch)		Corner Weight (lb.)			
	Shipping	Net	a	b	c	d	e	A	B	C	D
LAU090HYV1, LAU120HYV1	81.8	76.9	19-31/32	9-11/32	5-21/32	22	12-31/32	10.0	11.7	27.7	27.6
LAU180HYV1, LAU240HYV1	130.1	121.3	21-3/32	13-25/32	6-23/32	21-1/2	13-13/32	20.6	18.3	38.8	43.6

INDOOR UNIT DIMENSIONS

LAN090HYV1, LAN120HYV1



Unit: Inch

Product Data



INDOOR UNIT DIMENSIONS

LAN180HYV1, LAN240HYV1

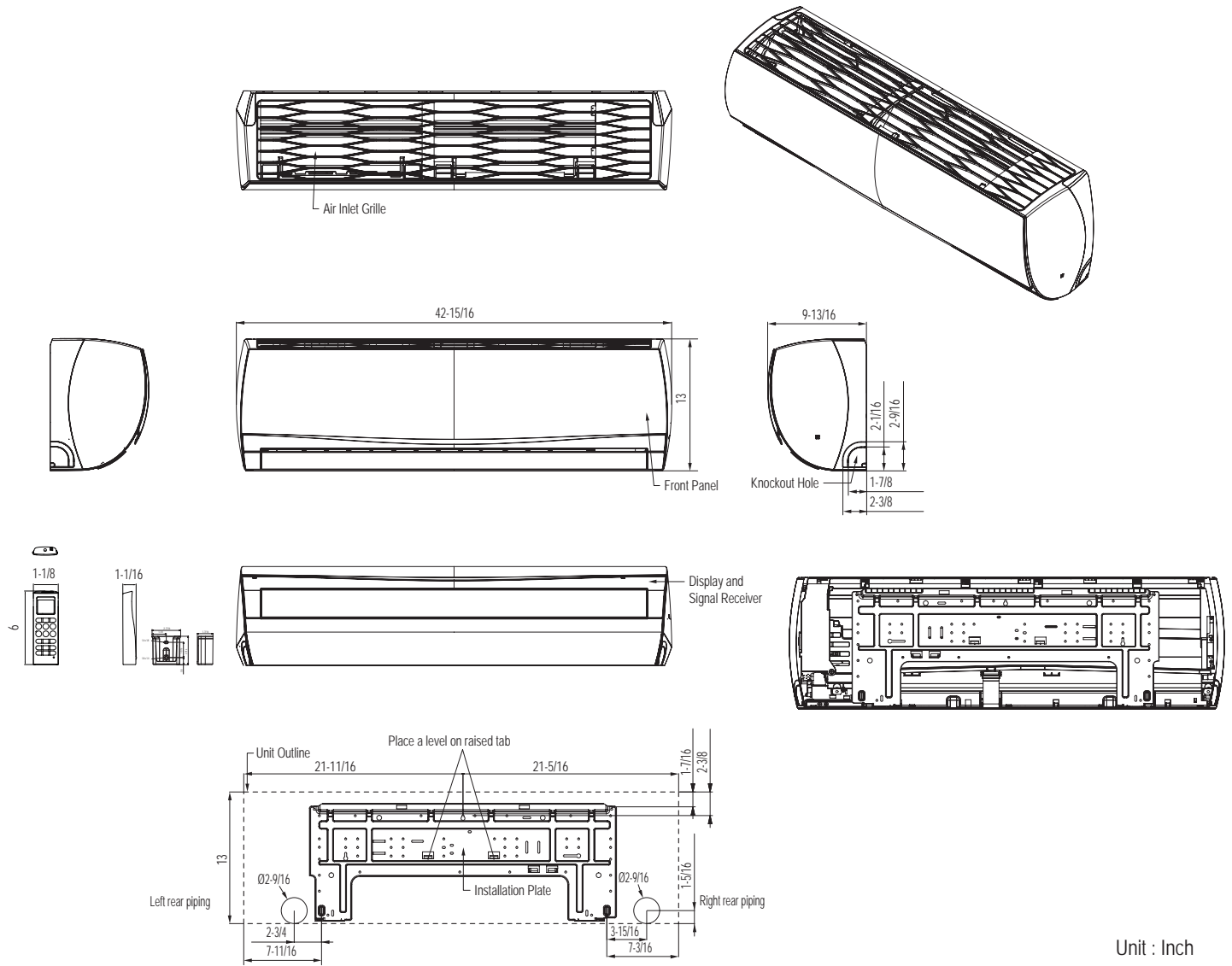

Unit : Inch

OUTDOOR UNIT ACOUSTIC DATA

Figure 2: Outdoor Unit Sound Levels

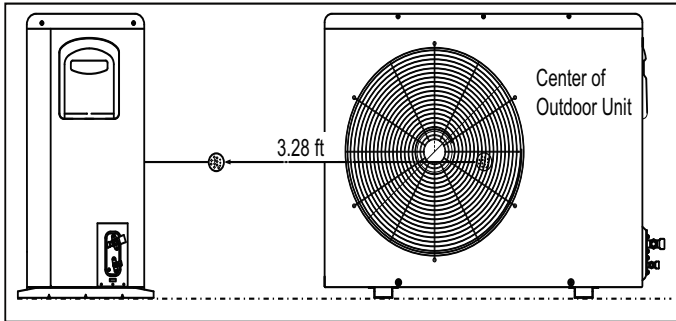

- Measurements are taken 3.28 ft away from the front of the unit.
- Sound pressure levels are measured in dB(A) with a tolerance of ± 3 .
- Sound pressure levels are tested in an anechoic chamber under ISO Standard 3745.
- Sound level will vary depending on a range of factors including the construction (acoustic absorption coefficient) of a particular room in which the unit was installed.

Table 6: Outdoor Unit Acoustic Data

Model	Sound Pressure Levels (dB[A])	
	Cooling (Max)	Heating (Max.)
LAU090HYV1	45	45
LAU120HYV1	45	45
LAU180HYV1	57	57
LAU240HYV1	57	57

Figure 3: Sound Pressure Levels for LAU090-120HYV1 Outdoor Units.

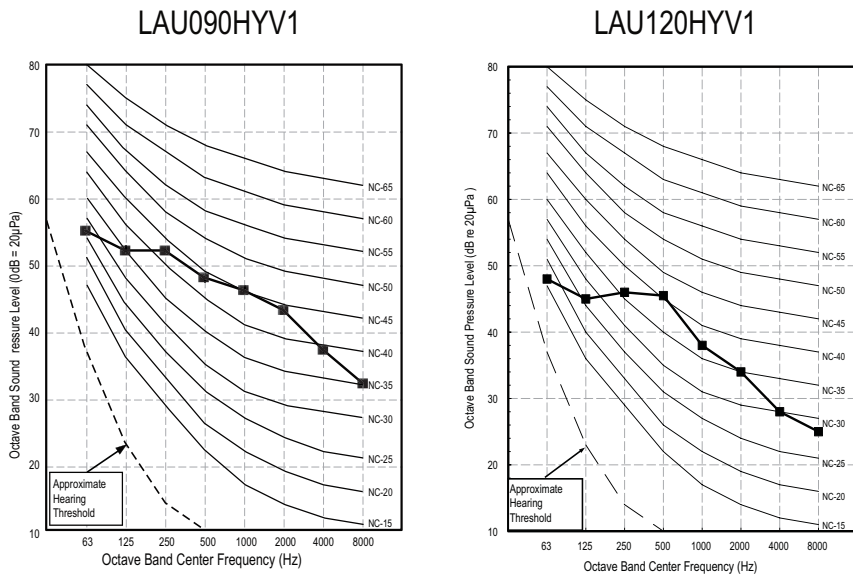
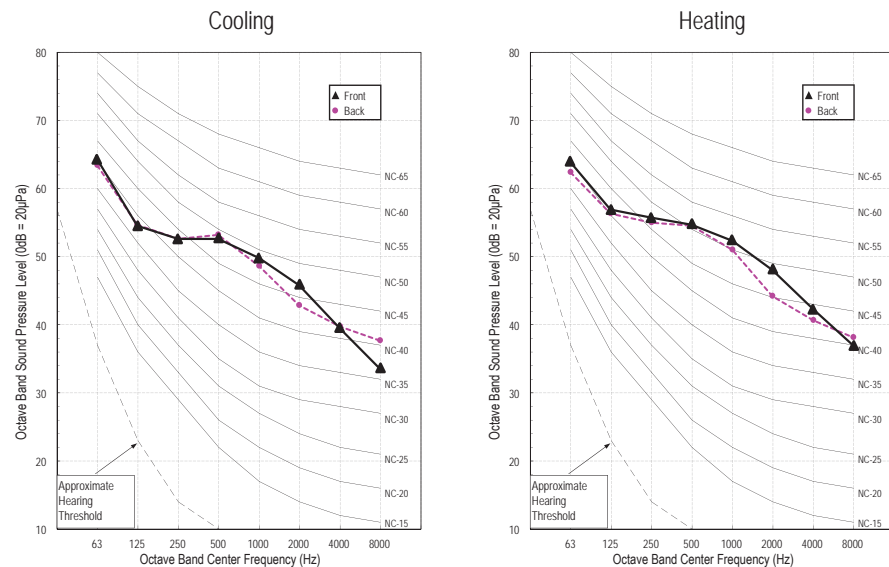

Figure 4: Sound Pressure Levels for LAU180-240HYV1 Outdoor Units.

LAU180-240HYV1



INDOOR ACOUSTIC DATA

Figure 5: Indoor Unit Sound Levels

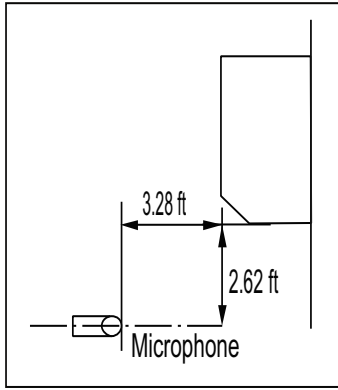

- Measurements are taken 3.28 ft away from the front of the unit.
- Sound pressure levels are measured in dB(A) with a tolerance of ± 3 .
- Sound pressure levels are tested in an anechoic chamber under ISO Standard 3745.
- Sound level will vary depending on a range of factors including the construction (acoustic absorption coefficient) of a particular room in which the unit was installed.

Table 7: Indoor Unit Acoustic Data

Model	Sound Pressure Levels (dB[A])					
	Cooling			Heating		
	H	M	L	H	M	L
LAN090HYV1	42	36	25	42	36	25
LAN120HYV1	42	36	25	42	36	25
LAN180HYV1	47	42	37	47	42	37
LAN240HYV1	47	42	37	47	42	37

Figure 6: Sound Pressure Levels for LAN090-120HYV1 Indoor Units.

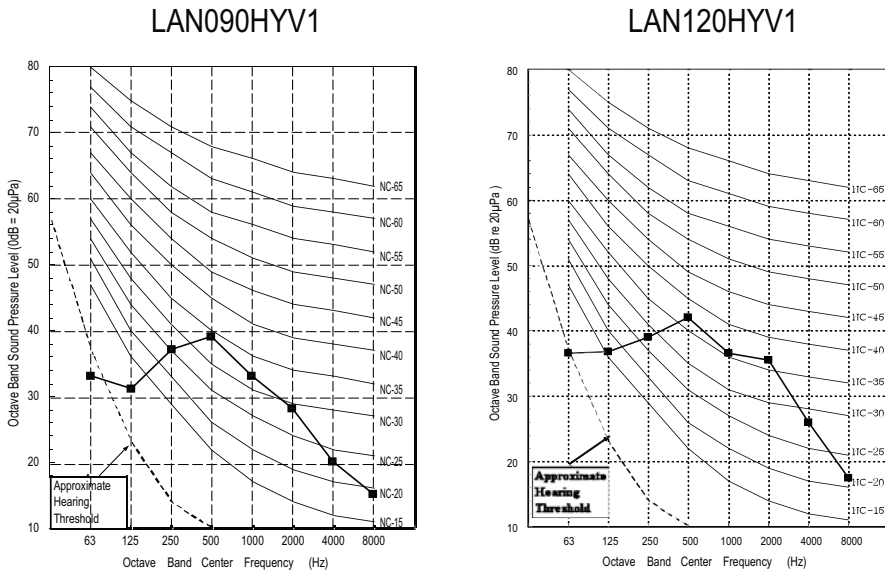
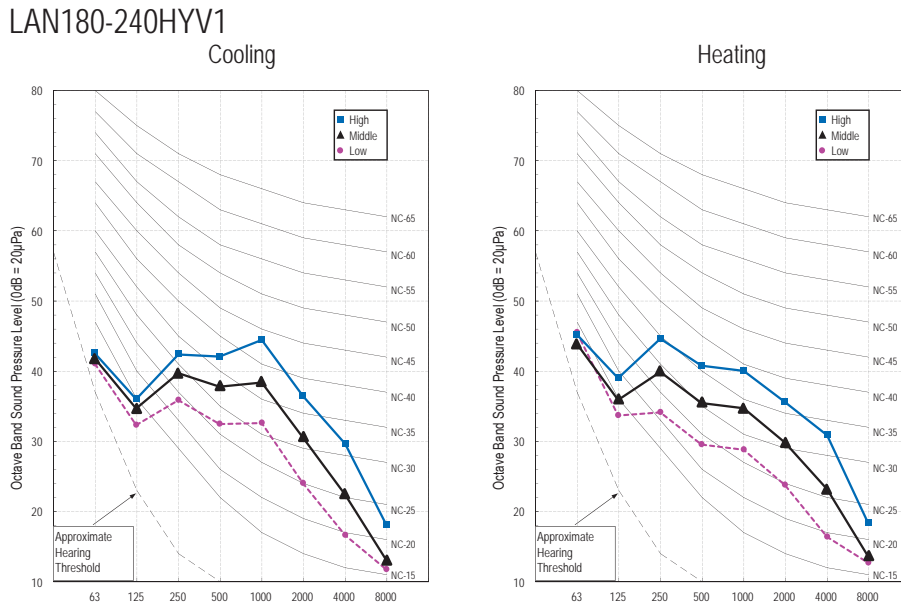
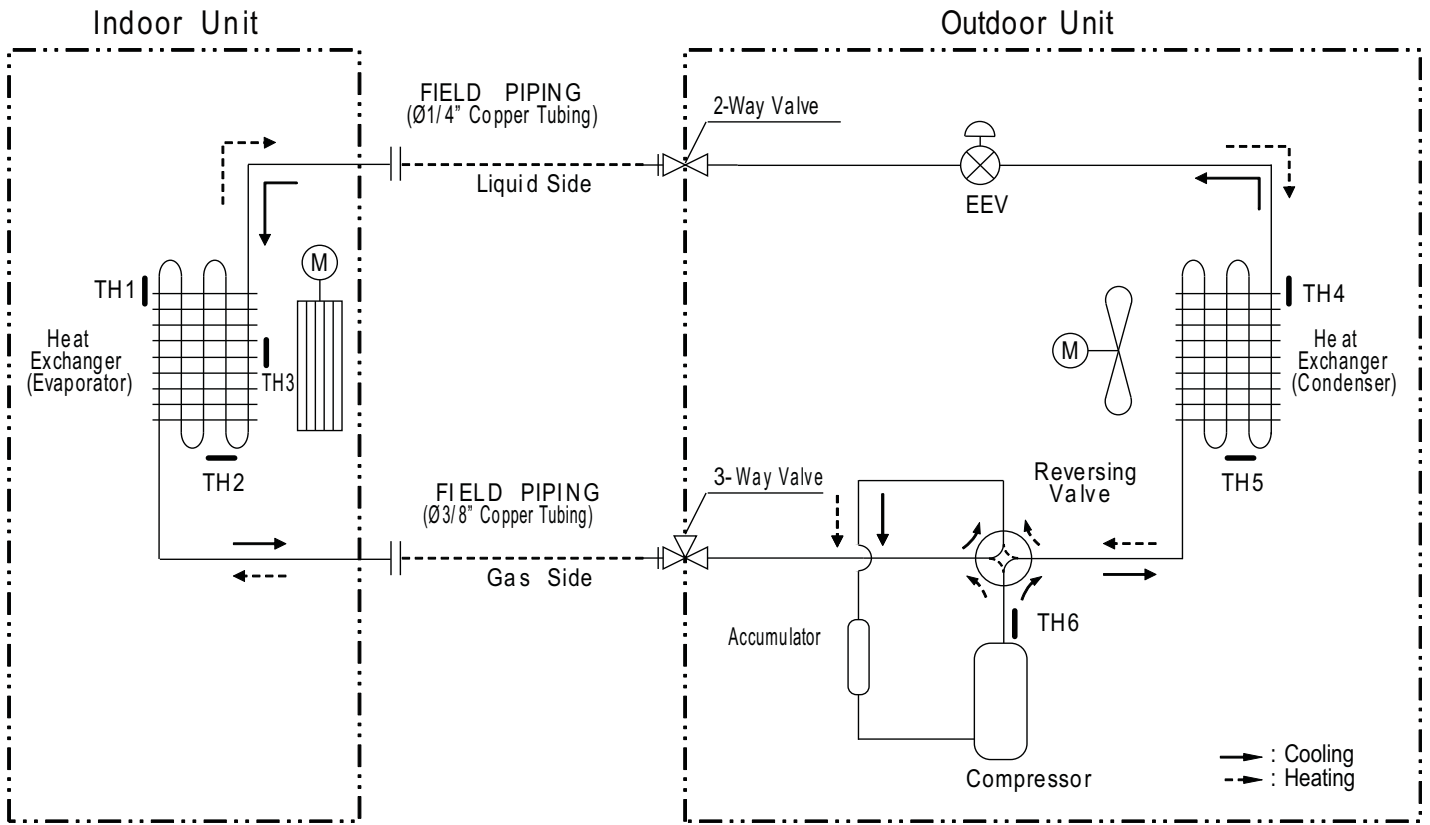

Figure 7: Sound Pressure Levels for LAN180-240HYV1 Indoor Units.













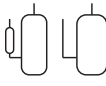

REFRIGERANT FLOW DIAGRAMS

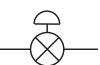
LAU/LAN090HYV1, LAU/LAN120HYV1



Product Data

Thermistor	Description	PCB Connector
TH1	Indoor air temperature thermistor	CN-TH1 (Indoor)
TH2	Water level sensor (optional)	CN-TH2 (Indoor)
TH3	Evaporator middle temperature thermistor	CN-TH3 (Indoor)
TH4	Outdoor air temperature thermistor	CN-TH1 (Outdoor)
TH5	Condensing temperature thermistor	
TH6	Discharge pipe temperature thermistor	CN-TH2 (Outdoor)

Appendix	 Heat Exchanger	 Propeller Fan	 Cross Flow Fan	 Compressor	 Accumulator
	 Four-Way Valve	 EEV (Electronic Expansion Valve)	 Capillary Tube	 Two-Way Valve  Three-Way Valve	 Temperature Sensor
	 Pressure Sensor	 Pressure Switch	 Check Valve	 Flare Joint	

REFRIGERANT FLOW DIAGRAMS

LAU/LAN180HYV1, LAU/LAN240HYV1

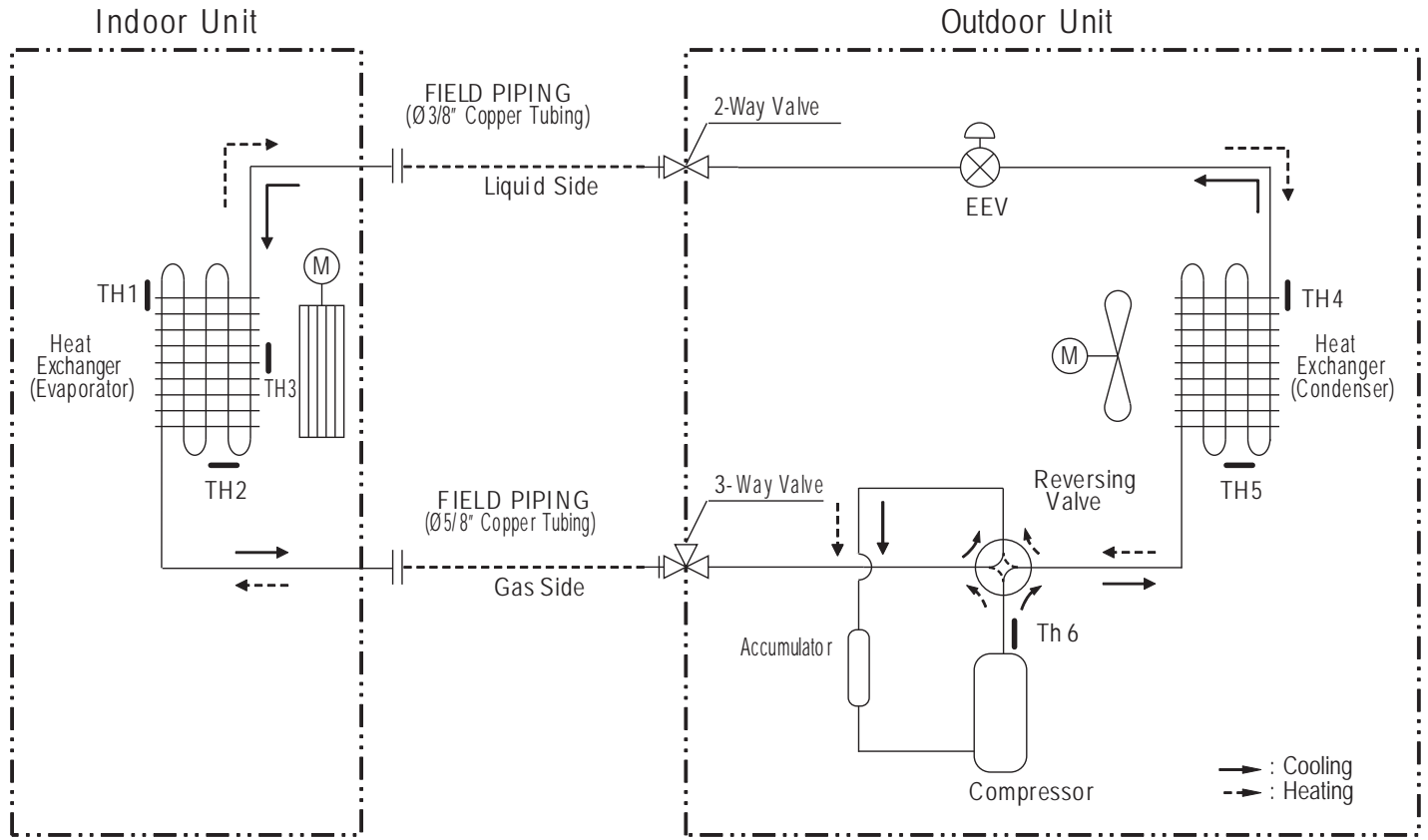

Thermistor	Description	PCB Connector
TH1	Indoor air temperature thermistor	CN-TH1 (Indoor)
TH2	Water level sensor (optional)	CN-TH2 (Indoor)
TH3	Evaporator middle temperature thermistor	CN-TH3 (Indoor)
TH4	Outdoor air temperature thermistor	CN-TH1 (Outdoor)
TH5	Condensing temperature thermistor	
TH6	Discharge pipe temperature thermistor	CN-TH2 (Outdoor)

Appendix	Heat Exchanger	Propeller Fan	Cross Flow Fan	Compressor	Accumulator
	Four-Way Valve	EEV (Electronic Expansion Valve)	Capillary Tube	Two-Way Valve Three-Way Valve	Temperature Sensor
	Pressure Sensor	Pressure Switch	Check Valve	Flare Joint	

WIRING DIAGRAM

LAN090HYV1, LAN120HYV1

- : Factory Wiring
- - - : Field Wiring
- ⋯ : OPTION

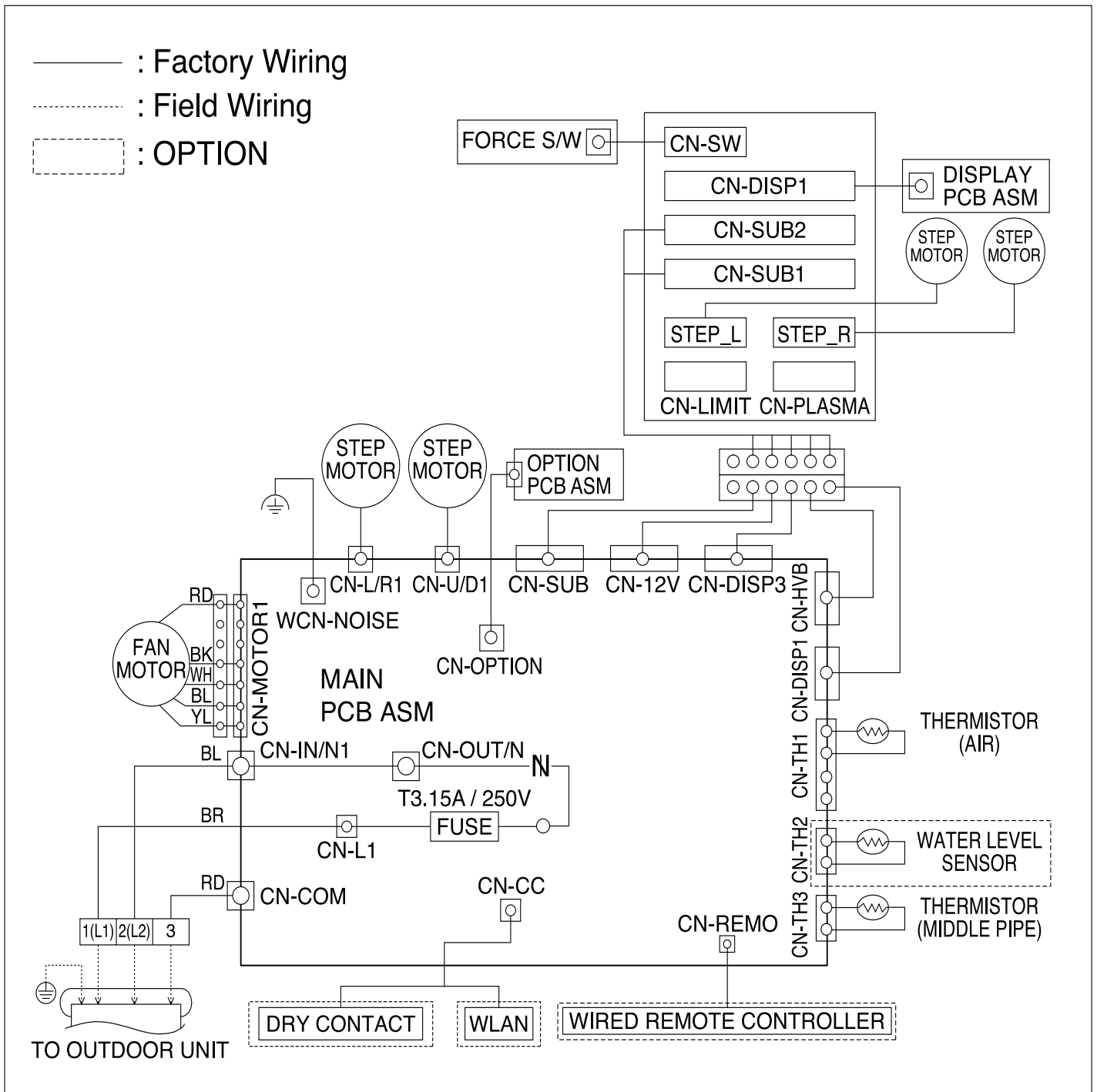

Product Data

WIRING DIAGRAM

LAN180HYV1, LAN240HYV1

- : Factory Wiring
- - - : Field Wiring
- ⋯ : OPTION

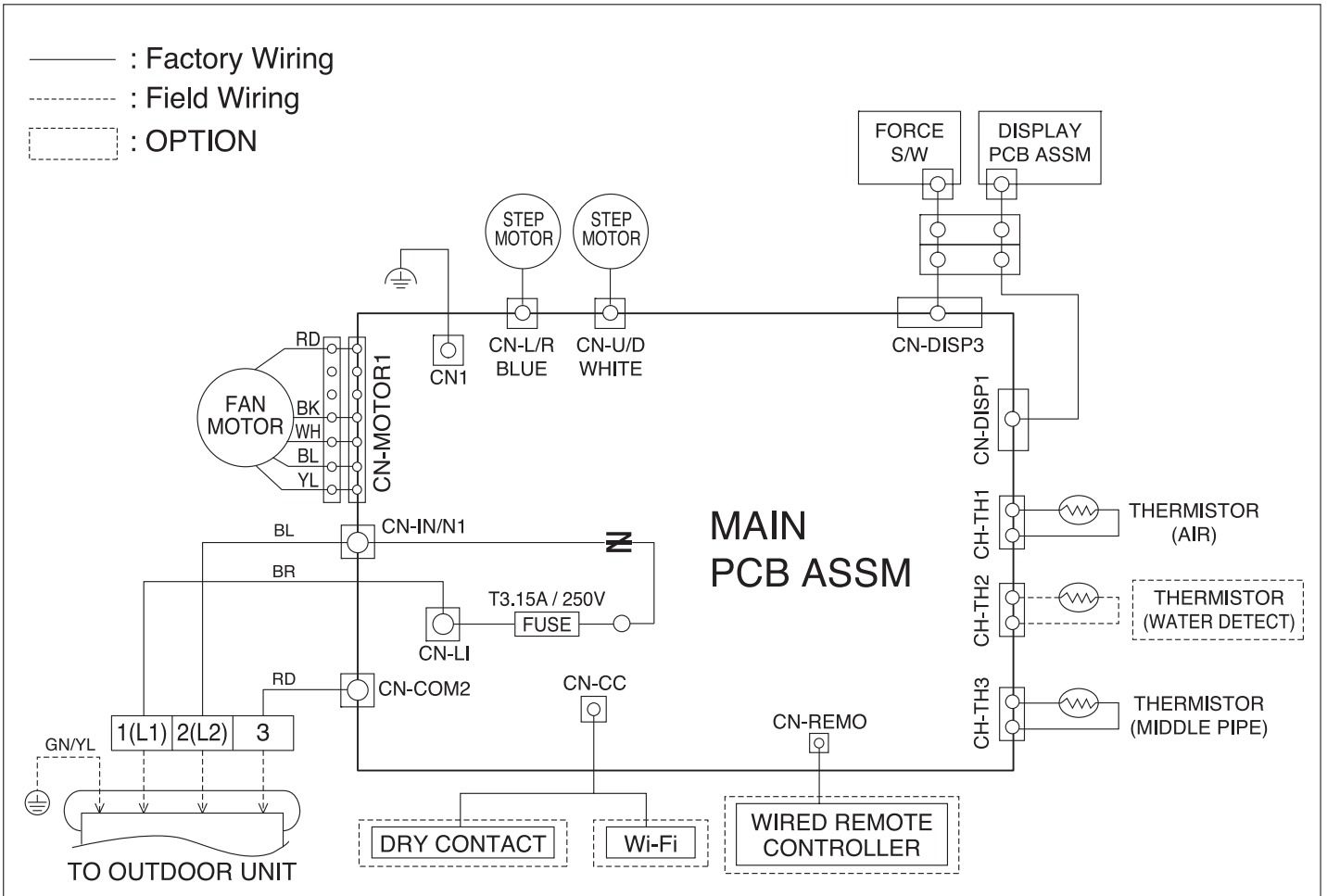

WIRING DIAGRAM

LAU090HYV1, LAU120HYV1

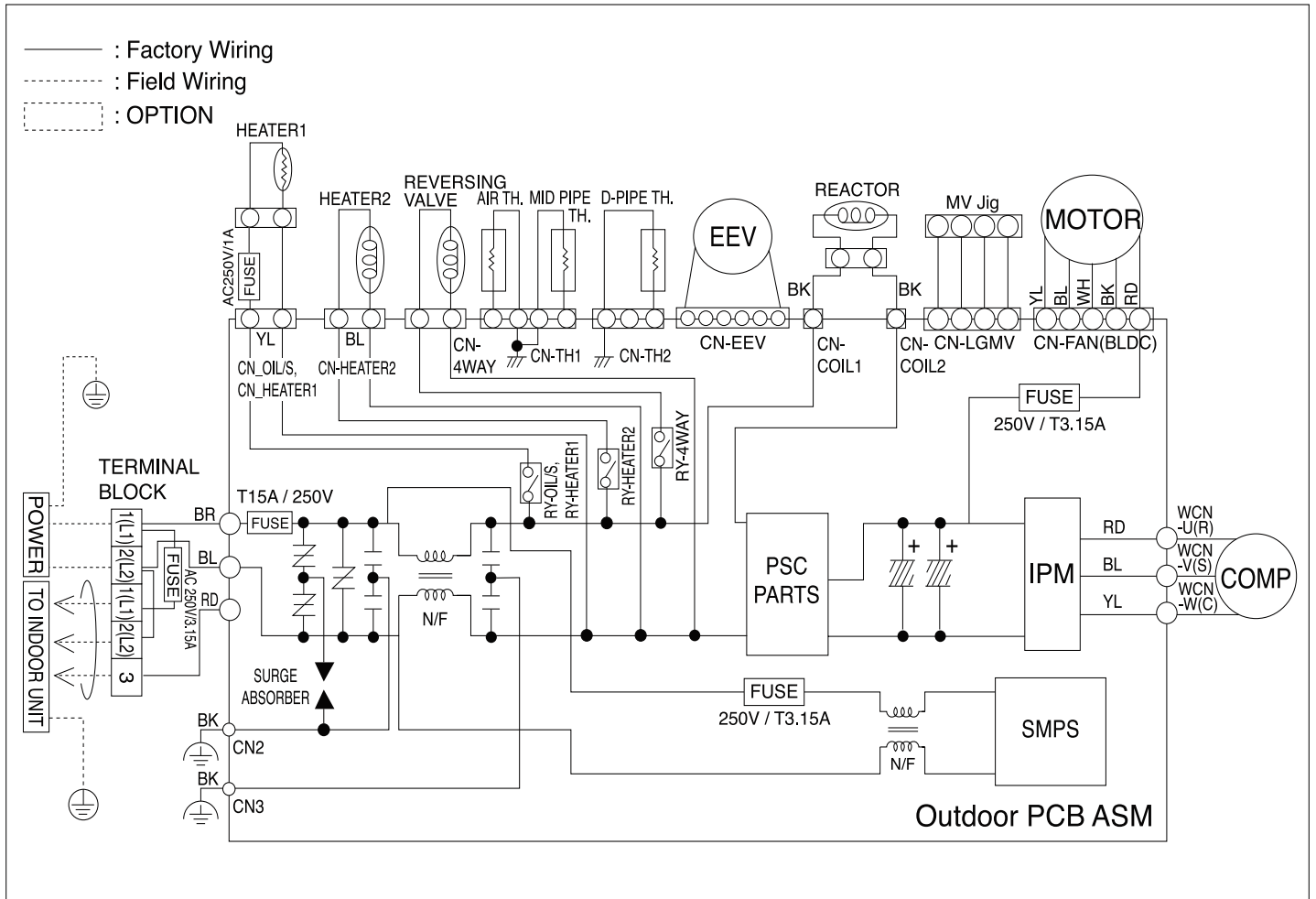

Product Data

WIRING DIAGRAM

LAU180HYV1, LAU240HYV1

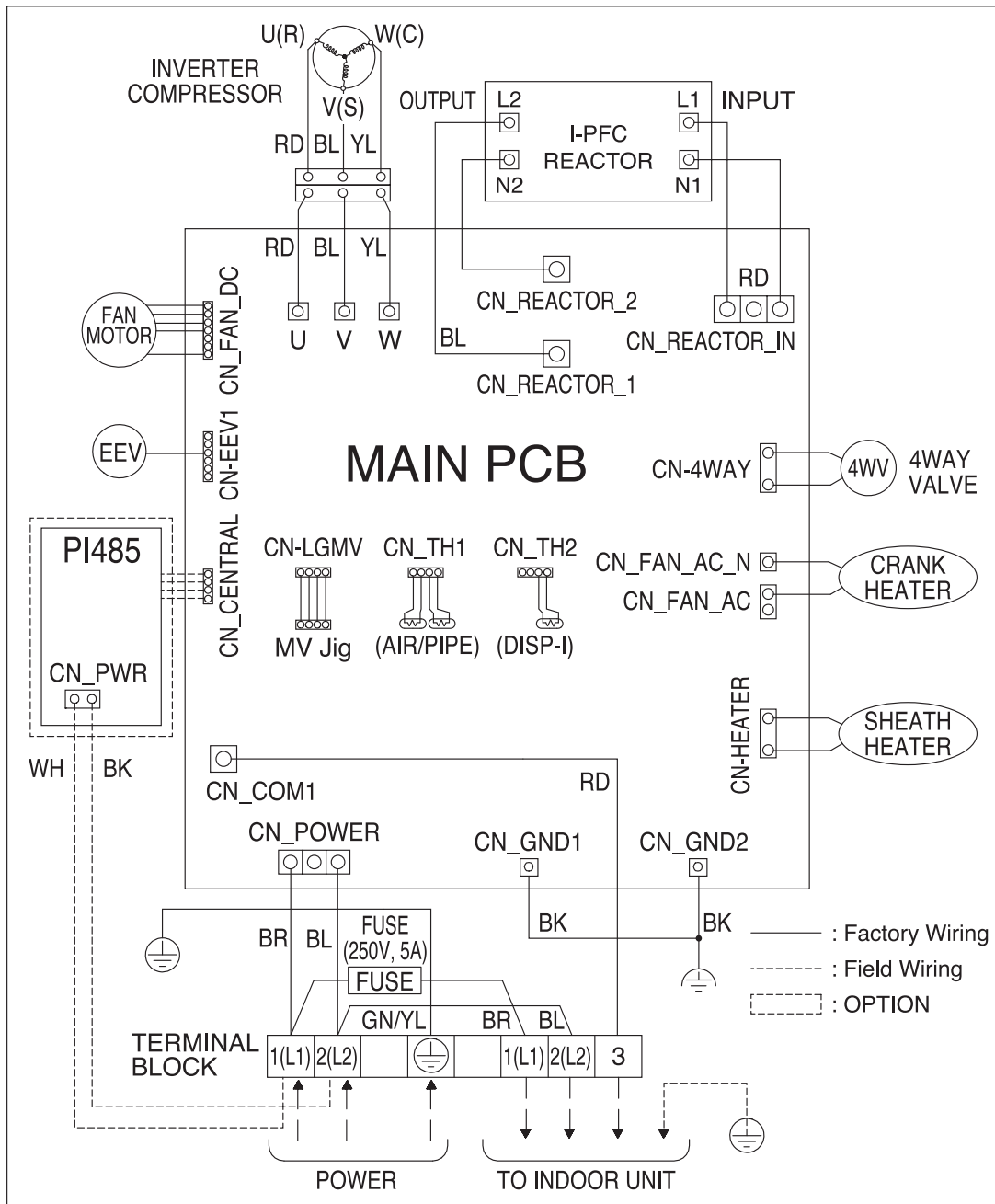

LG Monitoring View (LGMV) Diagnostic Software and Cable

(PRCTSL1 and PRCTFE1)

LGMV software allows the service technician or commissioning agent to connect a computer USB port to the outdoor unit main printed circuit board (PCB) using an accessory cable without the need for a separate interface device. The main screen for LGMV shall allow user to view the following real time data on one screen:

- Actual inverter compressor speed
- Target inverter compressor speed
- Actual outdoor fan speed
- Target outdoor unit fan speed
- Actual superheat
- Inverter compressor current value
- Outdoor air temperature
- Actual high pressure/saturation temperature
- Actual low pressure/saturation temperature
- Suction temperature
- Inverter compressor discharge temperature
- Outdoor coil pipe temperature
- Liquid line pipe temperature
- Inverter compressor operation indicator light
- Four-way reversing valve operation indicator light
- Pressure graph showing actual low pressure and actual high pressure levels
- Error code display
- Operating mode indicator
- Total number of connected indoor units (for multi zone systems)
- Communication indicator lights
- Unit error code
- Indoor unit capacity
- Indoor unit operating mode
- Indoor unit fan speed
- Indoor unit room temperature
- Indoor unit inlet pipe temperature
- Indoor unit outlet pipe temperature



Additional screens can be accessed by tabs on the main screen:

1. Cycleview: Graphic of internal components including:
 - Compressors showing actual speeds
 - EEVs
 - IDUs
 - Low and high pressures
 - Temperature and pressure sensors
 - Four-way reversing valve
 - Outdoor fans showing status and speeds
2. Setting: Converts metric values to imperial values.
3. Making Data: Recording of real time data to a separate file created to be stored on the user's computer.
4. Loading Data: Recorded data from a saved ".CSV" file can be loaded to create an LGMV session.
5. Electrical Data: The lower half of main screen is changed to show the following:
 - Inverter compressor
 - Amps
 - Volts
 -
 - Power Hz
 - Inverter control board fan Hz

The software is available in a high version with all of the features listed above. The low version has all features as the high version without Target High Pressure and Target Low Pressure values shown on main screen.

In lieu of connecting to the ODU, user has the option to connect to IDU with the use of a USB to RS-485 connector kit. When connected through IDU, user will not be able to record data.

This software can be used to both commission new systems and troubleshoot existing systems. LGMV data can be recorded to a ".CSV" file and emailed to an LG representative to assist with diagnostic evaluations.

Recommended Minimum PC Configuration:

- CPU: Pentium® IV 1.6 GHz
- Operating System: Windows® NT/2000/XP/Vista
- Main Memory: 256 MB
- Hard Disk: 600 MB when operating
- Web Browser: Internet Explorer® 5.0

PERFORMANCE DATA

“Cooling Capacity” on page 29

“Heating Capacity” on page 31

“Maximum Heating Capacity” on page 33

“Air Flow and Temperature Distributions Graphs” on page 35

PERFORMANCE DATA

Cooling Capacity

LA090HYV1, LA120HYV1

Table 8: LAN090HYV1/LAU090HYV1 Cooling Capacities.

Outdoor Air Temp. (°F DB)	Indoor Air Temperature (°F DB/ °F WB)																				
	64 / 53			68 / 57			72 / 61			77 / 64			80 / 67			86 / 72			90 / 75		
	TC	SHC	PI	TC	SHC	PI	TC	SHC	PI	TC	SHC	PI	TC	SHC	PI	TC	SHC	PI	TC	SHC	PI
0	5.45	5.21	0.23	6.81	5.55	0.27	8.18	5.89	0.31	9.88	6.31	0.36	10.91	6.56	0.39	9.10	7.15	0.32	7.90	7.55	0.27
5	5.34	5.14	0.24	6.68	5.47	0.28	8.02	5.80	0.32	9.69	6.22	0.38	10.70	6.47	0.41	8.93	7.05	0.33	7.75	7.44	0.28
7	5.38	5.18	0.24	6.73	5.52	0.28	8.08	5.85	0.33	9.76	6.27	0.38	10.77	6.53	0.41	8.99	7.12	0.34	7.80	7.51	0.29
10	5.44	5.25	0.24	6.80	5.59	0.29	8.16	5.94	0.33	9.86	6.36	0.39	10.88	6.62	0.42	9.08	7.22	0.34	7.88	7.61	0.29
14	5.51	5.35	0.25	6.89	5.70	0.29	8.27	6.04	0.34	9.99	6.48	0.39	11.03	6.74	0.43	9.20	7.35	0.35	7.99	7.75	0.30
23	5.92	5.74	0.24	7.12	6.11	0.29	8.32	6.49	0.35	9.82	6.95	0.41	10.72	7.23	0.45	9.43	7.89	0.36	8.57	8.32	0.30
25	6.01	5.83	0.25	7.18	6.19	0.30	8.36	6.55	0.35	9.83	7.01	0.41	10.71	7.28	0.45	9.54	7.97	0.36	8.75	8.43	0.31
30	6.24	6.06	0.27	7.35	6.39	0.32	8.46	6.73	0.36	9.85	7.14	0.42	10.68	7.39	0.45	9.80	8.18	0.38	9.20	8.71	0.33
35	6.47	6.28	0.29	7.52	6.59	0.33	8.56	6.90	0.37	9.87	7.28	0.43	10.66	7.51	0.46	10.05	8.39	0.39	9.65	8.99	0.35
40	6.70	6.51	0.31	7.69	6.79	0.34	8.67	7.07	0.38	9.90	7.42	0.43	10.63	7.63	0.46	10.31	8.61	0.41	10.10	9.26	0.37
45	6.94	6.74	0.32	7.85	6.99	0.36	8.77	7.24	0.39	9.92	7.55	0.44	10.61	7.74	0.46	10.57	8.82	0.42	10.55	9.54	0.39
50	7.17	6.96	0.34	8.02	7.19	0.37	8.88	7.41	0.40	9.94	7.69	0.44	10.58	7.86	0.47	10.83	9.03	0.44	11.00	9.81	0.41
55	7.40	7.19	0.36	8.19	7.38	0.39	8.98	7.58	0.42	9.96	7.83	0.45	10.56	7.98	0.47	11.09	9.24	0.45	11.45	10.09	0.44
60	7.63	7.41	0.38	8.36	7.58	0.40	9.08	7.75	0.43	9.99	7.96	0.46	10.53	8.09	0.47	11.35	9.45	0.46	11.90	10.36	0.46
65	7.56	7.34	0.40	8.25	7.55	0.42	8.94	7.76	0.44	9.80	8.02	0.47	10.31	8.17	0.49	11.13	9.46	0.48	11.68	10.32	0.48
70	7.49	7.28	0.42	8.14	7.52	0.44	8.79	7.76	0.46	9.61	8.07	0.49	10.09	8.25	0.50	10.91	9.47	0.50	11.46	10.28	0.51
75	7.43	7.21	0.44	8.04	7.49	0.46	8.65	7.77	0.48	9.42	8.12	0.50	9.87	8.33	0.52	10.69	9.47	0.53	11.24	10.23	0.53
80	7.36	7.14	0.46	7.93	7.46	0.48	8.51	7.77	0.50	9.22	8.17	0.52	9.66	8.41	0.53	10.48	9.48	0.55	11.02	10.19	0.55
85	7.29	7.08	0.48	7.82	7.43	0.49	8.36	7.78	0.51	9.03	8.22	0.54	9.44	8.48	0.55	10.26	9.48	0.57	10.80	10.15	0.58
90	7.22	7.01	0.49	7.72	7.40	0.51	8.22	7.79	0.53	8.84	8.27	0.55	9.22	8.56	0.56	10.04	9.49	0.59	10.58	10.10	0.60
95	7.15	6.94	0.51	7.61	7.37	0.53	8.07	7.79	0.55	8.65	8.32	0.57	9.00	8.64	0.58	9.82	9.49	0.61	10.36	10.06	0.62
100	6.96	6.76	0.52	7.43	7.20	0.54	7.91	7.65	0.56	8.50	8.20	0.58	8.86	8.54	0.59	9.65	9.34	0.61	10.17	9.88	0.63
105	6.77	6.58	0.53	7.26	7.04	0.55	7.75	7.51	0.56	8.35	8.08	0.58	8.72	8.43	0.60	9.48	9.19	0.62	9.99	9.70	0.64
110	6.59	6.39	0.54	7.08	6.88	0.55	7.58	7.36	0.57	8.21	7.97	0.59	8.58	8.33	0.61	9.31	9.04	0.63	9.80	9.51	0.65
115	6.35	6.17	0.54	6.83	6.64	0.56	7.32	7.11	0.58	7.92	7.70	0.60	8.28	8.05	0.61	8.99	8.73	0.64	9.47	9.19	0.66
118	6.21	6.03	0.55	6.68	6.49	0.56	7.16	6.95	0.58	7.75	7.53	0.60	8.10	7.88	0.62	8.80	8.55	0.64	9.27	9.00	0.66
122	6.02	6.15	0.55	6.48	6.62	0.57	6.94	7.09	0.59	7.51	7.68	0.61	7.86	8.04	0.62	8.54	8.72	0.65	8.99	9.18	0.67

Table 9: LAN120HYV1/LAU120HYV1 Cooling Capacities.

Outdoor Air Temp. (°F DB)	Indoor Air Temperature (°F DB/ °F WB)																				
	64 / 53			68 / 57			72 / 61			77 / 64			80 / 67			86 / 72			90 / 75		
	TC	SHC	PI	TC	SHC	PI	TC	SHC	PI	TC	SHC	PI	TC	SHC	PI	TC	SHC	PI	TC	SHC	PI
0	6.66	5.37	0.31	8.33	5.72	0.37	10.00	6.07	0.42	12.08	6.50	0.50	13.33	6.77	0.54	11.12	7.38	0.44	9.65	7.79	0.37
5	6.53	5.30	0.33	8.17	5.64	0.38	9.80	5.98	0.44	11.85	6.41	0.52	13.08	6.67	0.56	10.91	7.27	0.46	9.47	7.68	0.39
7	6.58	5.35	0.33	8.22	5.69	0.39	9.87	6.04	0.45	11.93	6.47	0.52	13.17	6.73	0.57	10.99	7.34	0.46	9.53	7.75	0.39
10	6.65	5.42	0.33	8.31	5.77	0.40	9.97	6.12	0.46	12.05	6.56	0.53	13.30	6.82	0.58	11.10	7.44	0.47	9.63	7.85	0.40
14	6.74	5.52	0.34	8.42	5.87	0.40	10.11	6.23	0.47	12.22	6.68	0.54	13.48	6.95	0.59	11.25	7.57	0.48	9.76	7.99	0.41
23	7.23	5.92	0.34	8.70	6.31	0.41	10.17	6.69	0.48	12.00	7.17	0.57	13.10	7.45	0.62	11.53	8.13	0.49	10.48	8.58	0.41
25	7.34	6.02	0.35	8.78	6.39	0.41	10.22	6.76	0.48	12.01	7.22	0.57	13.09	7.50	0.62	11.65	8.22	0.50	10.70	8.70	0.42
30	7.63	6.25	0.37	8.98	6.59	0.43	10.34	6.94	0.50	12.04	7.37	0.58	13.06	7.62	0.63	11.97	8.44	0.52	11.25	8.98	0.45
35	7.91	6.48	0.40	9.19	6.80	0.46	10.47	7.11	0.51	12.07	7.51	0.59	13.03	7.74	0.63	12.29	8.66	0.54	11.80	9.27	0.48
40	8.19	6.71	0.42	9.39	7.00	0.48	10.59	7.29	0.53	12.09	7.65	0.59	12.99	7.86	0.63	12.61	8.88	0.56	12.35	9.55	0.51
45	8.48	6.95	0.45	9.60	7.21	0.50	10.72	7.46	0.54	12.12	7.79	0.60	12.96	7.98	0.64	12.92	9.09	0.58	12.90	9.83	0.54
50	8.76	7.18	0.47	9.80	7.41	0.52	10.85	7.64	0.56	12.15	7.93	0.61	12.93	8.10	0.64	13.24	9.31	0.60	13.45	10.12	0.57
55	9.05	7.41	0.50	10.01	7.61	0.54	10.97	7.82	0.57	12.18	8.07	0.62	12.90	8.22	0.65	13.56	9.53	0.62	14.00	10.40	0.60
60	9.33	7.64	0.52	10.22	7.82	0.56	11.10	7.99	0.59	12.21	8.21	0.63	12.87	8.35	0.65	13.88	9.75	0.64	14.55	10.69	0.63
65	9.25	7.57	0.55	10.08	7.79	0.58	10.92	8.00	0.61	11.97	8.27	0.65	12.60	8.43	0.68	13.61	9.76	0.67	14.28	10.64	0.66
70	9.16	7.50	0.58	9.95	7.76	0.61	10.75	8.01	0.64	11.74	8.32	0.67	12.34	8.51	0.70	13.34	9.76	0.70	14.01	10.60	0.70
75	9.08	7.44	0.60	9.82	7.72	0.63	10.57	8.01	0.66	11.51	8.37	0.70	12.07	8.59	0.72	13.07	9.77	0.72	13.74	10.55	0.73
80	8.99	7.37	0.63	9.69	7.69	0.66	10.40	8.02	0.68	11.27	8.42	0.72	11.80	8.67	0.74	12.80	9.77	0.75	13.47	10.51	0.76
85	8.91	7.30	0.66	9.56	7.66	0.68	10.22	8.02	0.71	11.04	8.48	0.74	11.53	8.75	0.76	12.54	9.78	0.78	13.20	10.46	0.79
90	8.82	7.23	0.68	9.43	7.63	0.71	10.04	8.03	0.73	10.81	8.53	0.76	11.27	8.83	0.78	12.27	9.78	0.81	12.93	10.42	0.83
95	8.74	7.16	0.71	9.30	7.60	0.73	9.87	8.03	0.75	10.58	8.58	0.78	11.00	8.91	0.80	12.00	9.79	0.84	12.67	10.38	0.86
100	8.51	6.97	0.72	9.09	7.43	0.74	9.67	7.89	0.77	10.39	8.46	0.79	10.83	8.80	0.81	11.79	9.63	0.85	12.44	10.19	0.87
105	8.28	6.78	0.73	8.87	7.26	0.75	9.47	7.74	0.78	10.21	8.34	0.81	10.66	8.70	0.82	11.59	9.48	0.86	12.21	10.00	0.88
110	8.05	6.59	0.74	8.66	7.09	0.76	9.27	7.59	0.79	10.03	8.22	0.82	10.49	8.59	0.84	11.38	9.32	0.87	11.98	9.81	0.90
115	7.76	6.36	0.75	8.35	6.84	0.77	8.94	7.33	0.80	9.68	7.94	0.83	10.12	8.30	0.84	10.99	9.01	0.88	11.57	9.48	0.91
118	7.59	6.22	0.75	8.17	6.70	0.78	8.75	7.17	0.80	9.47	7.77	0.83	9.90	8.13	0.85	10.76	8.82	0.89	11.33	9.28	0.91
122	7.36	6.34	0.76	7.92	6.83	0.79	8.48	7.32	0.81	9.18	7.92	0.84	9.60	8.29	0.86	10.44	9.00	0.90	10.99	9.47	0.92

DB: Dry Bulb Temperature (°F) WB: Wet Bulb Temperature (°F) TC: Total Capacity (kBtu/h)
 SHC: Sensible Capacity (kBtu/h) PI: Power Input (kW) (includes compressor, indoor fan motor and outdoor fan motor)

1. All capacities are net, evaporator fan motor heat is deducted.
2. Cooling range with the Low Ambient Baffle Kit (sold separately) is 0°F to +122°F.
3. Grey shading indicates reference data. When operating the unit at this temperature, these values

- can be different by discontinuous operation.
4. Direct interpolation is permissible. Do not extrapolate.
- Nominal capacity as rated: 0 ft. above sea level with 25 ft. of refrigerant piping.
 0 ft. level difference between outdoor and indoor units.
- Nominal cooling capacity rating obtained with air entering the indoor unit at 80°F dry bulb (DB) and 67°F wet bulb (WB), and outdoor ambient conditions of 9

PERFORMANCE DATA

Cooling Capacity

LA180HYV1, LA240HYV1

Table 10: LAN180HYV1/LAU180HYV1 Cooling Capacities.

Outdoor Air Temp. (°F DB)	Indoor Air Temperature (°F DB/ °F WB)																				
	64 / 53			68 / 57			72 / 61			77 / 64			80 / 67			86 / 72			90 / 75		
	TC	SHC	PI	TC	SHC	PI	TC	SHC	PI	TC	SHC	PI	TC	SHC	PI	TC	SHC	PI	TC	SHC	PI
0	11.02	8.67	0.52	13.78	9.23	0.62	16.54	9.79	0.72	19.99	10.50	0.84	22.06	10.92	0.91	18.40	11.91	0.74	15.97	12.56	0.63
5	10.81	8.55	0.55	13.51	9.10	0.65	16.22	9.65	0.75	19.60	10.35	0.88	21.63	10.76	0.95	18.05	11.74	0.78	15.66	12.39	0.66
7	10.88	8.63	0.55	13.61	9.18	0.66	16.33	9.74	0.76	19.74	10.44	0.89	21.78	10.86	0.96	18.18	11.84	0.78	15.77	12.50	0.67
10	10.99	8.74	0.56	13.75	9.31	0.67	16.50	9.88	0.77	19.94	10.59	0.90	22.01	11.01	0.98	18.36	12.01	0.80	15.93	12.67	0.68
14	11.14	8.90	0.58	13.93	9.48	0.68	16.72	10.05	0.79	20.21	10.78	0.92	22.30	11.21	1.00	18.61	12.22	0.81	16.15	12.90	0.69
23	11.96	9.56	0.57	14.39	10.18	0.69	16.82	10.79	0.81	19.85	11.57	0.95	21.67	12.03	1.04	19.07	13.12	0.83	17.34	13.85	0.69
25	12.15	9.71	0.58	14.53	10.31	0.70	16.90	10.91	0.82	19.87	11.66	0.96	21.65	12.11	1.05	19.28	13.26	0.84	17.70	14.04	0.71
30	12.62	10.08	0.63	14.87	10.64	0.73	17.11	11.19	0.84	19.92	11.89	0.97	21.60	12.30	1.05	19.81	13.62	0.88	18.61	14.49	0.76
35	13.09	10.46	0.67	15.20	10.97	0.77	17.32	11.48	0.87	19.96	12.11	0.99	21.55	12.50	1.06	20.33	13.97	0.91	19.52	14.95	0.81
40	13.56	10.83	0.71	15.54	11.30	0.80	17.53	11.76	0.89	20.01	12.34	1.00	21.50	12.69	1.07	20.86	14.32	0.95	20.43	15.41	0.86
45	14.03	11.21	0.75	15.88	11.63	0.84	17.74	12.05	0.92	20.06	12.57	1.02	21.45	12.88	1.08	21.38	14.67	0.98	21.34	15.87	0.91
50	14.50	11.58	0.80	16.22	11.96	0.87	17.95	12.33	0.94	20.10	12.80	1.03	21.40	13.08	1.09	21.91	15.03	1.01	22.25	16.33	0.96
55	14.97	11.96	0.84	16.56	12.29	0.90	18.16	12.62	0.97	20.15	13.03	1.05	21.35	13.27	1.10	22.43	15.38	1.05	23.16	16.79	1.02
60	15.44	12.33	0.88	16.90	12.62	0.94	18.37	12.90	0.99	20.20	13.25	1.06	21.29	13.47	1.10	22.96	15.73	1.08	24.07	17.24	1.07
65	15.30	12.22	0.93	16.69	12.57	0.98	18.07	12.91	1.03	19.81	13.34	1.10	20.85	13.60	1.14	22.51	15.74	1.13	23.62	17.17	1.12
70	15.16	12.11	0.97	16.47	12.51	1.02	17.78	12.92	1.07	19.42	13.42	1.14	20.41	13.73	1.17	22.07	15.75	1.18	23.18	17.10	1.18
75	15.02	12.00	1.02	16.25	12.46	1.07	17.49	12.93	1.11	19.04	13.51	1.17	19.97	13.86	1.21	21.63	15.76	1.22	22.73	17.03	1.23
80	14.87	11.89	1.06	16.04	12.41	1.11	17.20	12.94	1.15	18.65	13.59	1.21	19.53	13.99	1.24	21.18	15.77	1.27	22.29	16.96	1.29
85	14.73	11.78	1.11	15.82	12.36	1.15	16.91	12.95	1.19	18.27	13.68	1.25	19.08	14.12	1.28	20.74	15.78	1.32	21.84	16.89	1.34
90	14.59	11.66	1.15	15.61	12.31	1.19	16.62	12.96	1.23	17.88	13.76	1.28	18.64	14.25	1.31	20.30	15.79	1.36	21.40	16.81	1.39
95	14.45	11.55	1.20	15.39	12.26	1.23	16.33	12.97	1.27	17.50	13.85	1.32	18.20	14.38	1.35	19.85	15.80	1.41	20.95	16.74	1.45
100	14.07	11.25	1.21	15.03	11.99	1.25	16.00	12.73	1.29	17.20	13.65	1.34	17.92	14.21	1.37	19.51	15.55	1.43	20.57	16.44	1.47
105	13.70	10.95	1.23	14.68	11.72	1.27	15.66	12.49	1.31	16.89	13.45	1.36	17.63	14.03	1.39	19.17	15.29	1.45	20.19	16.14	1.49
110	13.32	10.64	1.25	14.33	11.45	1.29	15.33	12.25	1.33	16.59	13.26	1.38	17.35	13.86	1.41	18.83	15.04	1.47	19.81	15.83	1.51
115	12.84	10.26	1.26	13.82	11.04	1.30	14.79	11.83	1.35	16.01	12.81	1.40	16.74	13.39	1.43	18.18	14.54	1.49	19.15	15.30	1.53
118	12.56	10.03	1.27	13.51	10.80	1.31	14.47	11.57	1.35	15.66	12.54	1.40	16.38	13.11	1.43	17.80	14.23	1.50	18.75	14.98	1.54
122	12.18	10.23	1.29	13.11	11.02	1.33	14.03	11.81	1.37	15.19	12.79	1.42	15.89	13.38	1.45	17.27	14.52	1.51	18.18	15.28	1.56

Table 11: LAN240HYV1/LAU240HYV1 Cooling Capacities.

Outdoor Air Temp. (°F DB)	Indoor Air Temperature (°F DB/ °F WB)																				
	64 / 53			68 / 57			72 / 61			77 / 64			80 / 67			86 / 72			90 / 75		
	TC	SHC	PI	TC	SHC	PI	TC	SHC	PI	TC	SHC	PI	TC	SHC	PI	TC	SHC	PI	TC	SHC	PI
0	13.32	10.35	0.68	16.66	11.02	0.81	19.99	11.69	0.93	24.16	12.53	1.09	26.66	13.03	1.19	22.25	14.21	0.97	19.30	15.00	0.82
5	13.07	10.20	0.72	16.34	10.86	0.85	19.61	11.52	0.98	23.70	12.35	1.14	26.15	12.84	1.24	21.82	14.01	1.01	18.93	14.78	0.86
7	13.16	10.29	0.72	16.45	10.96	0.86	19.74	11.63	0.99	23.86	12.46	1.15	26.33	12.96	1.25	21.97	14.14	1.02	19.06	14.92	0.87
10	13.29	10.44	0.73	16.62	11.11	0.87	19.95	11.79	1.00	24.10	12.63	1.17	26.60	13.14	1.27	22.20	14.33	1.04	19.26	15.12	0.88
14	13.47	10.62	0.75	16.84	11.31	0.89	20.22	12.00	1.03	24.43	12.86	1.20	26.96	13.38	1.30	22.50	14.59	1.06	19.52	15.40	0.90
23	14.46	11.41	0.74	17.40	12.14	0.90	20.33	12.88	1.05	24.00	13.80	1.24	26.20	14.36	1.36	23.06	15.66	1.08	20.96	16.53	0.90
25	14.69	11.59	0.76	17.56	12.30	0.91	20.43	13.02	1.06	24.02	13.91	1.25	26.18	14.45	1.36	23.31	15.83	1.10	21.40	16.75	0.93
30	15.25	12.03	0.82	17.97	12.70	0.96	20.68	13.36	1.10	24.08	14.19	1.27	26.11	14.68	1.38	23.94	16.25	1.15	22.50	17.30	0.99
35	15.82	12.48	0.87	18.38	13.09	1.00	20.94	13.70	1.13	24.13	14.46	1.29	26.05	14.91	1.39	24.58	16.67	1.19	23.60	17.85	1.06
40	16.39	12.93	0.93	18.79	13.48	1.05	21.19	14.04	1.16	24.19	14.73	1.31	25.99	15.15	1.40	25.21	17.09	1.23	24.70	18.39	1.13
45	16.96	13.38	0.98	19.20	13.88	1.09	21.44	14.38	1.20	24.24	15.00	1.33	25.93	15.38	1.41	25.85	17.51	1.28	25.79	18.94	1.19
50	17.52	13.82	1.04	19.61	14.27	1.13	21.69	14.72	1.23	24.30	15.27	1.35	25.86	15.61	1.42	26.48	17.94	1.32	26.89	19.49	1.26
55	18.09	14.27	1.09	20.02	14.66	1.18	21.95	15.06	1.26	24.36	15.55	1.37	25.80	15.84	1.43	27.12	18.36	1.37	27.99	20.03	1.32
60	18.66	14.72	1.15	20.43	15.06	1.22	22.20	15.40	1.30	24.41	15.82	1.39	25.74	16.07	1.44	27.75	18.78	1.41	29.09	20.58	1.39
65	18.49	14.59	1.21	20.17	15.00	1.28	21.85	15.41	1.35	23.95	15.92	1.43	25.21	16.23	1.49	27.21	18.79	1.47	28.55	20.49	1.46
70	18.32	14.45	1.27	19.91	14.94	1.33	21.50	15.42	1.40	23.48	16.02	1.48	24.67	16.38	1.53	26.68	18.80	1.53	28.02	20.41	1.53
75	18.15	14.32	1.33	19.65	14.88	1.39	21.14	15.43	1.45	23.01	16.12	1.53	24.14	16.54	1.58	26.14	18.81	1.59	27.48	20.32	1.60
80	17.98	14.19	1.38	19.39	14.81	1.44	20.79	15.44	1.50	22.55	16.22	1.58	23.60	16.69	1.62	25.61	18.82	1.65	26.94	20.24	1.68
85	17.81	14.05	1.44	19.12	14.75	1.50	20.44	15.45	1.56	22.08	16.33	1.63	23.07	16.85	1.67	25.07	18.83	1.72	26.40	20.15	1.75
90	17.64	13.92	1.50	18.86	14.69	1.55	20.09	15.46	1.61	21.62	16.43	1.67	22.53	17.00	1.71	24.53	18.84	1.78	25.87	20.07	1.82
95	17.47	13.79	1.56	18.60	14.63	1.61	19.74	15.47	1.66	21.15	16.53	1.72	22.00	17.16	1.76	24.00	18.85	1.84	25.33	19.98	1.89
100	17.01	13.43	1.58	18.17	14.31	1.63	19.34	15.19	1.69	20.79	16.29	1.75	21.66	16.95	1.79	23.58	18.55	1.86	24.87	19.62	1.92
105	16.56	13.06	1.61	17.75	13.98	1.66	18.94	14.91	1.71	20.42	16.06	1.77	21.31	16.75	1.81	23.17	18.25	1.89	24.41	19.26	1.94
110	16.10	12.70	1.63	17.32	13.66	1.68	18.54	14.62	1.74	20.06	15.82	1.80	20.97	16.54	1.84	22.76	17.95	1.92	23.95	18.89	1.97
115	15.53	12.25	1.65	16.70	13.18	1.70	17.88	14.12	1.75	19.35	15.28	1.82	20.24	15.99	1.86	21.98	17.35	1.94	23.14	18.26	2.00
118	15.18	11.98	1.66	16.34	12.89	1.71	17.49	13.81	1.77	18.93	14.96	1.83	19.80	15.65	1.87	21.52	16.99	1.95	22.66	17.88	2.01
122	14.72	12.22	1.6																		

PERFORMANCE DATA

Heating Capacity

LA090HYV1, LA120HYV1

Table 12: LAN090HYV1/LAU090HYV1 Heating Capacities.

Outdoor Air Temp.		Indoor Air Temperature (°F DB/ °F WB)													
°F DB	°F WB	60		64		68		70		72		75		86	
		TC	PI	TC	PI	TC	PI	TC	PI	TC	PI	TC	PI	TC	PI
-12	-13	5.08	0.43	4.93	0.44	4.88	0.44	4.83	0.42	4.79	0.42	4.69	0.43	4.58	0.43
-3	-4	5.61	0.47	5.44	0.47	5.39	0.47	5.33	0.46	5.29	0.46	5.19	0.46	5.06	0.46
0	-1	6.11	0.52	5.92	0.51	5.86	0.51	5.81	0.51	5.76	0.51	5.64	0.5	5.51	0.5
1	0	6.38	0.55	6.18	0.54	6.12	0.54	6.06	0.53	6.01	0.53	5.89	0.53	5.75	0.53
6	5	6.46	0.54	6.27	0.54	6.2	0.54	6.14	0.53	6.1	0.53	5.97	0.53	5.83	0.53
10	9	6.75	0.56	6.54	0.56	6.48	0.56	6.41	0.55	6.36	0.55	6.24	0.54	6.09	0.54
16	14	6.96	0.57	6.75	0.56	6.68	0.56	6.62	0.56	6.56	0.56	6.43	0.55	6.28	0.55
17	15	7.01	0.57	6.80	0.57	6.73	0.57	6.66	0.56	6.61	0.56	6.48	0.56	6.32	0.56
19	17	7.10	0.58	6.89	0.58	6.82	0.58	6.75	0.57	6.70	0.57	6.56	0.57	6.41	0.57
24	23	7.79	0.61	7.55	0.60	7.48	0.60	7.40	0.59	7.35	0.59	7.20	0.59	7.03	0.59
32	30	9.34	0.65	9.06	0.65	8.96	0.65	8.88	0.64	8.81	0.64	8.63	0.64	8.43	0.64
41	38	10.71	0.70	10.39	0.69	10.28	0.69	10.18	0.68	10.10	0.68	9.90	0.68	9.67	0.68
43	40	11.06	0.71	10.72	0.70	10.61	0.70	10.51	0.69	10.43	0.69	10.22	0.69	9.98	0.69
47	43	11.57	0.72	11.22	0.72	11.11	0.72	11.00	0.71	10.92	0.71	10.70	0.70	10.44	0.70
53	50	11.69	0.73	11.34	0.72	11.22	0.72	11.11	0.72	11.03	0.72	10.80	0.71	10.55	0.71
59	53	11.96	0.74	11.59	0.73	11.48	0.73	11.36	0.72	11.28	0.72	11.05	0.72	10.79	0.72
64	57	12.21	0.75	11.84	0.75	11.72	0.75	11.61	0.74	11.52	0.74	11.29	0.73	11.02	0.73
70	61	12.44	0.76	12.07	0.76	11.94	0.76	11.83	0.75	11.73	0.75	11.50	0.74	11.23	0.74
75	65	12.62	0.77	12.23	0.77	12.11	0.77	11.99	0.76	11.90	0.76	11.66	0.75	11.38	0.75

Table 13: LAN120HYV1/LAU120HYV1 Heating Capacities.

Outdoor Air Temp.		Indoor Air Temperature (°F DB/ °F WB)													
°F DB	°F WB	60		64		68		70		72		75		86	
		TC	PI	TC	PI	TC	PI	TC	PI	TC	PI	TC	PI	TC	PI
-12	-13	5.54	0.46	5.38	0.46	5.32	0.46	5.27	0.45	5.23	0.45	5.11	0.45	5	0.45
-3	-4	6.12	0.5	5.94	0.5	5.88	0.5	5.82	0.49	5.77	0.49	5.66	0.49	5.52	0.49
0	-1	6.66	0.55	6.46	0.54	6.4	0.54	6.33	0.54	6.28	0.54	6.16	0.53	6.01	0.53
1	0	6.96	0.58	6.74	0.57	6.68	0.57	6.61	0.56	6.56	0.56	6.43	0.56	6.28	0.56
6	5	7.05	0.57	6.84	0.57	6.77	0.57	6.7	0.56	6.65	0.56	6.52	0.56	6.36	0.56
10	9	7.36	0.59	7.14	0.59	7.07	0.59	7.00	0.58	6.94	0.58	6.80	0.58	6.64	0.58
16	14	7.59	0.60	7.36	0.59	7.29	0.59	7.22	0.59	7.16	0.59	7.02	0.58	6.85	0.58
17	15	7.65	0.60	7.41	0.60	7.34	0.60	7.27	0.59	7.21	0.59	7.07	0.59	6.90	0.59
19	17	7.75	0.62	7.51	0.61	7.44	0.61	7.36	0.61	7.31	0.61	7.16	0.60	6.99	0.60
24	23	8.50	0.64	8.24	0.63	8.16	0.63	8.08	0.63	8.02	0.63	7.85	0.62	7.67	0.62
32	30	10.19	0.69	9.88	0.68	9.78	0.68	9.68	0.68	9.61	0.68	9.41	0.67	9.19	0.67
41	38	11.69	0.74	11.33	0.73	11.22	0.73	11.11	0.72	11.02	0.72	10.80	0.71	10.55	0.71
43	40	12.06	0.75	11.70	0.74	11.58	0.74	11.47	0.73	11.38	0.73	11.15	0.73	10.88	0.73
47	43	12.63	0.77	12.24	0.76	12.12	0.76	12.00	0.75	11.91	0.75	11.67	0.74	11.39	0.74
53	50	12.75	0.77	12.37	0.77	12.24	0.77	12.12	0.76	12.03	0.76	11.79	0.75	11.51	0.75
59	53	13.04	0.78	12.65	0.77	12.52	0.77	12.40	0.77	12.30	0.77	12.05	0.76	11.77	0.76
64	57	13.32	0.80	12.92	0.79	12.79	0.79	12.66	0.78	12.56	0.78	12.31	0.77	12.02	0.77
70	61	13.57	0.81	13.16	0.80	13.03	0.80	12.90	0.79	12.80	0.79	12.54	0.78	12.25	0.78
75	65	13.76	0.82	13.35	0.81	13.21	0.81	13.08	0.80	12.98	0.80	12.72	0.79	12.42	0.79

DB: Dry Bulb Temperature (°F) WB: Wet Bulb Temperature (°F) TC: Total Capacity (kBtu/h)
 PI: Power Input (kW) (includes compressor, indoor fan motor and outdoor fan motor)
 1. All capacities are net, evaporator fan motor heat is deducted.
 2. Direct interpolation is permissible. Do not extrapolate.

Nominal capacity as rated: 0 ft. above sea level with 25 ft. of refrigerant piping.
 0 ft. level difference between outdoor and indoor units.

Nominal heating capacity rating obtained with air entering the indoor unit at 70°F dry bulb (DB) and 60°F wet bulb (WB), and outdoor ambient conditions of 47°F dry bulb (DB) and 43°F wet bulb (WB).



PERFORMANCE DATA

Heating Capacity

LA180HYV1, LA240HYV1

Table 14: LAN180HYV1/LAU180HYV1 Heating Capacities.

Outdoor Air Temp.		Indoor Air Temperature (°F DB/ °F WB)													
°F DB	°F WB	60		64		68		70		72		75		86	
		TC	PI	TC	PI	TC	PI	TC	PI	TC	PI	TC	PI	TC	PI
-12	-13	10.16	1.03	9.86	1.04	9.75	1.04	9.66	1.01	9.58	1.01	9.37	1.02	9.16	1.02
-3	-4	11.22	1.13	10.88	1.12	10.77	1.12	10.67	1.11	10.58	1.11	10.37	1.09	10.12	1.09
0	-1	12.22	1.24	11.85	1.23	11.73	1.23	11.61	1.21	11.52	1.21	11.29	1.20	11.02	1.20
1	0	12.37	1.25	12.00	1.24	11.88	1.24	11.76	1.23	11.67	1.23	11.43	1.21	11.16	1.21
6	5	12.93	1.29	12.53	1.28	12.41	1.28	12.29	1.27	12.19	1.27	11.95	1.26	11.66	1.26
10	9	13.50	1.34	13.09	1.32	12.95	1.32	12.83	1.31	12.73	1.31	12.47	1.30	12.17	1.30
16	14	13.92	1.35	13.50	1.34	13.36	1.34	13.23	1.32	13.13	1.32	12.87	1.31	12.56	1.31
17	15	14.02	1.36	13.59	1.35	13.45	1.35	13.32	1.34	13.22	1.34	12.95	1.32	12.64	1.32
19	17	14.21	1.39	13.77	1.38	13.64	1.38	13.50	1.37	13.40	1.37	13.13	1.35	12.82	1.35
24	23	15.58	1.44	15.11	1.43	14.96	1.43	14.81	1.42	14.69	1.42	14.40	1.40	14.06	1.40
32	30	18.68	1.56	18.11	1.54	17.93	1.54	17.75	1.53	17.61	1.53	17.26	1.51	16.85	1.51
41	38	21.43	1.66	20.78	1.65	20.57	1.65	20.37	1.63	20.21	1.63	19.80	1.61	19.33	1.61
43	40	22.12	1.69	21.45	1.67	21.23	1.67	21.02	1.65	20.86	1.65	20.44	1.64	19.95	1.64
47	43	23.15	1.73	22.45	1.71	22.22	1.71	22.00	1.69	21.83	1.69	21.39	1.68	20.88	1.68
53	50	23.38	1.74	22.67	1.73	22.44	1.73	22.22	1.71	22.05	1.71	21.61	1.69	21.09	1.69
59	53	23.91	1.76	23.19	1.74	22.95	1.74	22.73	1.73	22.55	1.73	22.10	1.71	21.57	1.71
64	57	24.42	1.79	23.68	1.78	23.44	1.78	23.21	1.76	23.03	1.76	22.57	1.74	22.03	1.74
70	61	24.89	1.82	24.13	1.80	23.89	1.80	23.65	1.79	23.47	1.79	23.00	1.77	22.45	1.77
75	65	25.23	1.85	24.47	1.83	24.22	1.83	23.98	1.81	23.80	1.81	23.32	1.79	22.76	1.79

Table 15: LAN240HYV1/LAU240HYV1 Heating Capacities.

Outdoor Air Temp.		Indoor Air Temperature (°F DB/ °F WB)													
°F DB	°F WB	60		64		68		70		72		75		86	
		TC	PI	TC	PI	TC	PI	TC	PI	TC	PI	TC	PI	TC	PI
-12	-13	12.47	1.34	12.10	1.35	11.97	1.35	11.86	1.31	11.76	1.31	11.50	1.33	11.25	1.33
-3	-4	13.77	1.46	13.36	1.45	13.22	1.45	13.09	1.43	12.99	1.43	12.73	1.42	12.43	1.42
0	-1	14.99	1.61	14.54	1.59	14.39	1.59	14.25	1.58	14.14	1.58	13.86	1.56	13.53	1.56
1	0	15.18	1.62	14.72	1.61	14.57	1.61	14.43	1.59	14.32	1.59	14.03	1.58	13.70	1.58
6	5	15.87	1.68	15.38	1.66	15.23	1.66	15.08	1.65	14.96	1.65	14.66	1.63	14.31	1.63
10	9	16.56	1.73	16.06	1.72	15.90	1.72	15.74	1.70	15.62	1.70	15.31	1.68	14.94	1.68
16	14	17.09	1.75	16.57	1.74	16.40	1.74	16.24	1.72	16.11	1.72	15.79	1.70	15.41	1.70
17	15	17.20	1.77	16.68	1.75	16.51	1.75	16.35	1.74	16.22	1.74	15.90	1.72	15.52	1.72
19	17	17.43	1.81	16.91	1.79	16.73	1.79	16.57	1.77	16.44	1.77	16.11	1.75	15.73	1.75
24	23	19.12	1.87	18.54	1.85	18.35	1.85	18.17	1.84	18.03	1.84	17.67	1.82	17.25	1.82
32	30	22.92	2.02	22.23	2.00	22.00	2.00	21.78	1.98	21.62	1.98	21.18	1.96	20.68	1.96
41	38	26.30	2.16	25.50	2.13	25.24	2.13	24.99	2.11	24.80	2.11	24.30	2.09	23.73	2.09
43	40	27.14	2.19	26.32	2.17	26.05	2.17	25.80	2.15	25.60	2.15	25.09	2.12	24.49	2.12
47	43	28.41	2.24	27.55	2.22	27.27	2.22	27.00	2.20	26.79	2.20	26.26	2.17	25.63	2.17
53	50	28.70	2.26	27.82	2.24	27.54	2.24	27.27	2.22	27.06	2.22	26.52	2.19	25.89	2.19
59	53	29.35	2.28	28.46	2.26	28.17	2.26	27.89	2.24	27.68	2.24	27.12	2.22	26.48	2.22
64	57	29.97	2.33	29.06	2.31	28.77	2.31	28.49	2.28	28.27	2.28	27.70	2.26	27.04	2.26
70	61	30.54	2.36	29.62	2.34	29.32	2.34	29.03	2.32	28.80	2.32	28.22	2.29	27.55	2.29
75	65	30.97	2.40	30.03	2.37	29.72	2.37	29.43	2.35	29.21	2.35	28.62	2.33	27.94	2.33

DB: Dry Bulb Temperature (°F) WB: Wet Bulb Temperature (°F) TC: Total Capacity (kBtu/h)
 PI: Power Input (kW) (includes compressor, indoor fan motor and outdoor fan motor)
 1. All capacities are net, evaporator fan motor heat is deducted.
 2. Direct interpolation is permissible. Do not extrapolate.

Nominal capacity as rated: 0 ft. above sea level with 25 ft. of refrigerant piping.
 0 ft. level difference between outdoor and indoor units.
 Nominal heating capacity rating obtained with air entering the indoor unit at 70°F dry bulb (DB) and 60°F wet bulb (WB), and outdoor ambient conditions of 47°F dry bulb (DB) and 43°F wet bulb (WB).

PERFORMANCE DATA

Maximum Heating Capacity LA090HYV1, LA120HYV1

Table 16: LAN090HYV1/LAU090HYV1 Maximum Heating Capacities.

Outdoor Air Temp.		Indoor Air Temperature (°F DB/ °F WB)													
°F DB	°F WB	60		64		68		70		72		75		86	
		TC	PI	TC	PI	TC	PI	TC	PI	TC	PI	TC	PI	TC	PI
-12	-13	7.79	1.01	7.83	1.02	7.86	1.03	7.92	1.05	7.78	1.04	7.59	1.04	6.99	1.05
-3	-4	9.82	1.06	9.76	1.06	9.71	1.06	9.69	1.06	9.62	1.08	9.47	1.10	9.02	1.17
0	-1	10.37	1.07	10.29	1.08	10.23	1.08	10.19	1.09	10.11	1.10	9.94	1.12	9.44	1.20
1	0	10.60	1.07	10.51	1.08	10.44	1.09	10.40	1.10	10.32	1.11	10.13	1.12	9.57	1.17
6	5	11.48	1.11	11.36	1.12	11.27	1.13	11.22	1.14	11.10	1.13	10.85	1.12	9.68	1.08
10	9	11.87	1.12	11.74	1.13	11.63	1.15	11.57	1.15	11.42	1.14	11.09	1.13	9.68	1.07
16	14	12.12	1.12	11.98	1.14	11.86	1.15	11.80	1.16	11.60	1.15	11.16	1.12	9.84	1.04
17	15	12.21	1.12	12.06	1.14	11.95	1.16	11.88	1.16	11.67	1.15	11.21	1.12	9.81	1.02
19	17	12.26	1.13	12.12	1.14	12.00	1.15	11.94	1.16	11.71	1.14	11.19	1.10	9.65	0.97
24	23	12.60	1.18	12.45	1.19	12.33	1.19	12.26	1.19	11.96	1.16	11.29	1.12	9.28	0.97
32	30	13.12	1.23	12.97	1.24	12.85	1.24	12.78	1.24	12.39	1.21	11.52	1.15	8.90	0.95
41	38	13.72	1.24	13.56	1.27	13.43	1.29	13.36	1.30	12.91	1.25	11.91	1.17	8.89	0.89
43	40	13.85	1.26	13.69	1.28	13.56	1.31	13.49	1.32	13.02	1.26	11.96	1.18	8.78	0.87
47	43	14.12	1.27	13.96	1.31	13.82	1.35	13.75	1.37	13.24	1.30	12.10	1.21	8.68	0.85
53	50	14.49	1.29	14.31	1.33	14.17	1.37	14.08	1.39	13.53	1.31	12.28	1.20	8.53	0.78
59	53	14.68	1.26	14.66	1.31	14.65	1.36	14.65	1.38	14.04	1.31	12.69	1.20	8.61	0.79
64	57	14.79	1.24	14.57	1.25	14.39	1.27	14.29	1.28	13.72	1.22	12.42	1.12	8.53	0.77
70	61	14.84	1.18	14.58	1.18	14.37	1.18	14.26	1.18	13.69	1.12	12.41	1.03	8.56	0.71
75	65	14.81	1.08	14.51	1.11	14.26	1.14	14.13	1.15	13.55	1.09	12.24	1.00	8.32	0.66

Table 17: LAN120HYV1/LAU120HYV1 Maximum Heating Capacities.

Outdoor Air Temp.		Indoor Air Temperature (°F DB/ °F WB)													
°F DB	°F WB	60		64		68		70		72		75		86	
		TC	PI	TC	PI	TC	PI	TC	PI	TC	PI	TC	PI	TC	PI
-12	-13	9.42	1.28	9.47	1.29	9.50	1.30	9.52	1.31	9.42	1.31	9.18	1.31	8.46	1.32
-3	-4	11.87	1.34	11.81	1.34	11.75	1.34	11.72	1.34	11.64	1.36	11.45	1.39	10.91	1.48
0	-1	12.54	1.35	12.45	1.36	12.37	1.37	12.32	1.37	12.23	1.39	12.03	1.42	11.41	1.51
1	0	12.82	1.35	12.72	1.37	12.63	1.38	12.58	1.39	12.48	1.40	12.25	1.42	11.57	1.48
6	5	13.95	1.41	13.81	1.42	13.69	1.44	13.72	1.47	13.49	1.44	13.18	1.42	11.77	1.37
10	9	14.47	1.43	14.31	1.45	14.18	1.46	14.11	1.47	13.93	1.46	13.52	1.44	11.81	1.37
16	14	14.84	1.45	14.67	1.47	14.53	1.49	14.45	1.50	14.21	1.48	13.67	1.45	12.05	1.34
17	15	14.96	1.45	14.79	1.47	14.64	1.49	14.56	1.50	14.31	1.48	13.74	1.45	12.02	1.32
19	17	15.05	1.46	14.88	1.48	14.73	1.49	14.65	1.50	14.37	1.47	13.74	1.42	11.85	1.26
24	23	15.45	1.52	15.27	1.52	15.12	1.53	15.03	1.53	14.67	1.49	13.85	1.44	11.38	1.25
32	30	16.07	1.56	15.89	1.57	15.73	1.57	15.65	1.57	15.17	1.53	14.11	1.46	10.90	1.21
41	38	16.78	1.56	16.59	1.59	16.43	1.61	16.34	1.63	15.79	1.56	14.56	1.47	10.87	1.11
43	40	16.94	1.57	16.74	1.60	16.58	1.63	16.49	1.64	15.92	1.57	14.62	1.47	10.74	1.08
47	43	17.26	1.56	17.06	1.61	16.89	1.66	16.80	1.69	16.18	1.61	14.79	1.49	10.61	1.04
53	50	17.71	1.59	17.49	1.64	17.31	1.69	17.21	1.71	16.53	1.62	15.00	1.48	10.42	0.97
59	53	17.93	1.56	17.91	1.62	17.90	1.68	17.89	1.71	17.16	1.61	15.50	1.48	10.52	0.97
64	57	18.07	1.52	17.81	1.55	17.59	1.57	17.47	1.58	16.76	1.50	15.17	1.39	10.42	0.95
70	61	18.13	1.46	17.82	1.45	17.56	1.45	17.42	1.45	16.72	1.38	15.16	1.27	10.46	0.88
75	65	18.09	1.33	17.72	1.37	17.43	1.40	17.26	1.42	16.55	1.35	14.95	1.23	10.16	0.82

DB: Dry Bulb Temperature (°F) WB: Wet Bulb Temperature (°F) TC: Total Capacity (kBtu/h)
 PI: Power Input (kW) (includes compressor, indoor fan motor and outdoor fan motor)
 1. All capacities are net, evaporator fan motor heat is deducted.
 2. Direct interpolation is permissible. Do not extrapolate.

Nominal capacity as rated: 0 ft. above sea level with 25 ft. of refrigerant piping.
 0 ft. level difference between outdoor and indoor units.

Nominal heating capacity rating obtained with air entering the indoor unit at 70°F dry bulb (DB) and 60°F wet bulb (WB), and outdoor ambient conditions of 47°F dry bulb (DB) and 43°F wet bulb (WB).

PERFORMANCE DATA

Maximum Heating Capacity

LA180HYV1, LA240HYV1

Table 18: LAN180HYV1/LAU180HYV1 Maximum Heating Capacities.

Outdoor Air Temp.		Indoor Air Temperature (°F DB/ °F WB)													
°F DB	°F WB	60		64		68		70		72		75		86	
		TC	PI	TC	PI	TC	PI	TC	PI	TC	PI	TC	PI	TC	PI
-12	-13	13.91	2.10	13.97	2.11	14.03	2.13	14.06	2.14	13.84	2.14	13.55	2.15	12.48	2.16
-3	-4	16.99	2.20	16.90	2.21	16.81	2.21	16.76	2.22	16.61	2.25	16.39	2.29	15.61	2.43
0	-1	17.95	2.23	17.82	2.24	17.69	2.26	17.63	2.27	17.46	2.30	17.22	2.34	16.33	2.50
1	0	18.34	2.25	18.20	2.27	18.06	2.29	18.00	2.30	17.80	2.31	17.54	2.34	16.57	2.43
6	5	19.76	2.32	19.58	2.34	19.39	2.37	19.30	2.39	19.04	2.37	18.68	2.34	17.36	2.25
10	9	20.89	2.33	20.68	2.36	20.46	2.39	20.37	2.41	20.01	2.38	19.54	2.35	17.78	2.24
16	14	22.21	2.34	21.97	2.37	21.73	2.41	21.62	2.42	21.13	2.39	20.47	2.34	18.04	2.17
17	15	22.40	2.36	22.16	2.40	21.91	2.43	21.80	2.44	21.31	2.39	20.63	2.33	18.13	2.07
19	17	22.95	2.37	22.70	2.40	22.45	2.42	22.34	2.43	21.76	2.38	20.97	2.31	18.07	2.04
24	23	24.31	2.39	24.05	2.40	23.78	2.40	23.66	2.41	22.88	2.35	21.81	2.26	17.91	1.97
32	30	25.70	2.31	25.43	2.32	25.15	2.33	25.02	2.33	23.99	2.25	22.59	2.15	17.44	1.79
41	38	27.01	2.16	26.72	2.20	26.43	2.24	26.31	2.26	25.11	2.16	23.48	2.03	17.50	1.54
43	40	27.29	2.07	27.00	2.11	26.71	2.15	26.58	2.17	25.32	2.07	23.60	1.93	17.30	1.43
47	43	27.67	1.99	27.37	2.06	27.07	2.12	26.94	2.15	25.59	2.04	23.75	1.89	17.01	1.33
53	50	28.39	2.03	28.07	2.09	27.74	2.15	27.59	2.18	26.12	2.05	24.10	1.88	16.71	1.23
59	53	28.75	1.99	28.73	2.06	28.71	2.14	28.70	2.17	27.09	2.05	24.90	1.87	16.88	1.24
64	57	28.98	1.94	28.58	1.97	28.19	2.01	28.01	2.02	26.47	1.91	24.38	1.76	16.70	1.21
70	61	29.08	1.86	28.61	1.85	28.15	1.85	27.93	1.85	26.42	1.75	24.35	1.61	16.77	1.12
75	65	29.01	1.70	28.47	1.74	27.92	1.79	27.68	1.81	26.13	1.71	24.02	1.56	16.29	1.04

Table 19: LAN240HYV1/LAU240HYV1 Maximum Heating Capacities.

Outdoor Air Temp.		Indoor Air Temperature (°F DB/ °F WB)													
°F DB	°F WB	60		64		68		70		72		75		86	
		TC	PI	TC	PI	TC	PI	TC	PI	TC	PI	TC	PI	TC	PI
-12	-13	17.07	2.72	17.14	2.74	17.22	2.76	17.25	2.77	16.99	2.78	16.63	2.79	15.32	2.81
-3	-4	20.85	2.86	20.74	2.87	20.63	2.87	20.58	2.88	20.38	2.91	20.12	2.97	19.16	3.16
0	-1	22.03	2.89	21.87	2.91	21.71	2.93	21.64	2.94	21.42	2.98	21.13	3.03	20.04	3.24
1	0	22.51	2.92	22.34	2.94	22.17	2.97	22.09	2.98	21.85	3.00	21.53	3.04	20.34	3.16
6	5	24.25	3.00	24.02	3.04	23.80	3.08	23.69	3.10	23.37	3.07	22.93	3.04	21.31	2.92
10	9	25.64	3.02	25.38	3.06	25.11	3.10	24.99	3.12	24.56	3.09	23.97	3.05	21.82	2.90
16	14	27.26	3.04	26.96	3.08	26.67	3.12	26.54	3.14	25.94	3.10	25.12	3.04	22.13	2.82
17	15	27.50	3.07	27.20	3.11	26.90	3.15	26.76	3.17	26.15	3.11	25.31	3.02	22.25	2.69
19	17	28.17	3.08	27.86	3.11	27.55	3.14	27.41	3.16	26.70	3.09	25.73	2.99	22.17	2.65
24	23	29.84	3.10	29.51	3.11	29.19	3.12	29.04	3.12	28.08	3.04	26.77	2.94	21.98	2.55
32	30	31.55	3.00	31.21	3.01	30.87	3.02	30.71	3.02	29.45	2.92	27.72	2.80	21.40	2.32
41	38	33.15	2.80	32.80	2.85	32.44	2.91	32.28	2.93	30.82	2.80	28.82	2.63	21.48	2.00
43	40	33.49	2.68	33.14	2.73	32.78	2.79	32.61	2.81	31.07	2.68	28.96	2.50	21.24	1.85
47	43	33.96	2.58	33.60	2.67	33.23	2.76	33.06	2.80	31.41	2.65	29.15	2.45	20.87	1.73
53	50	34.85	2.63	34.45	2.71	34.05	2.79	33.87	2.83	32.05	2.66	29.58	2.44	20.51	1.60
59	53	35.29	2.58	35.26	2.68	35.23	2.78	35.22	2.82	33.25	2.66	30.56	2.43	20.71	1.61
64	57	35.57	2.52	35.08	2.56	34.59	2.60	34.37	2.62	32.49	2.48	29.92	2.28	20.50	1.57
70	61	35.69	2.41	35.11	2.41	34.54	2.40	34.28	2.40	32.42	2.27	29.89	2.10	20.58	1.45
75	65	35.60	2.20	34.93	2.26	34.27	2.32	33.97	2.35	32.07	2.21	29.48	2.03	20.00	1.35

DB: Dry Bulb Temperature (°F) WB: Wet Bulb Temperature (°F) TC: Total Capacity (kBtu/h)
 PI: Power Input (kW) (includes compressor, indoor fan motor and outdoor fan motor)
 1. All capacities are net, evaporator fan motor heat is deducted.
 2. Direct interpolation is permissible. Do not extrapolate.

Nominal capacity as rated: 0 ft. above sea level with 25 ft. of refrigerant piping.
 0 ft. level difference between outdoor and indoor units.

Nominal heating capacity rating obtained with air entering the indoor unit at 70°F dry bulb (DB) and 60°F wet bulb (WB), and outdoor ambient conditions of 47°F dry bulb (DB) and 43°F wet bulb (WB).

PERFORMANCE DATA

Air Flow and Temperature Distribution Graphs

LAN090HYV1

Cooling

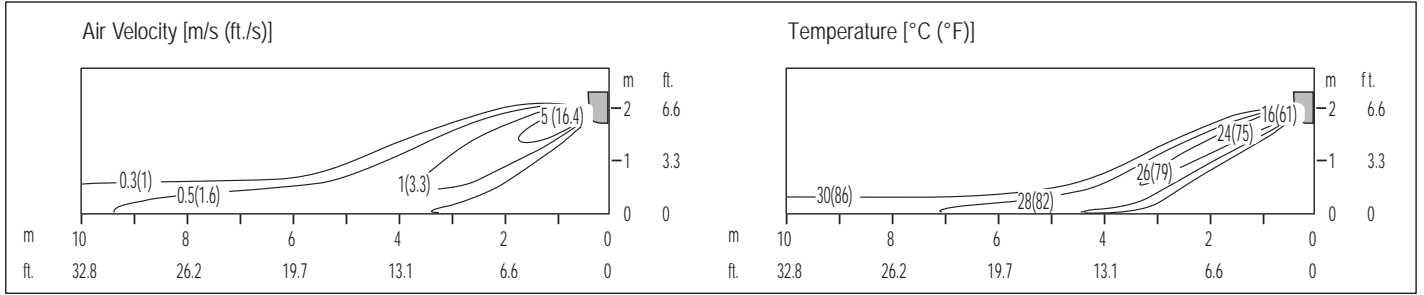

Side View

Discharge Angle: 70°

Vertical Louver: Center

Fan Speed: Power

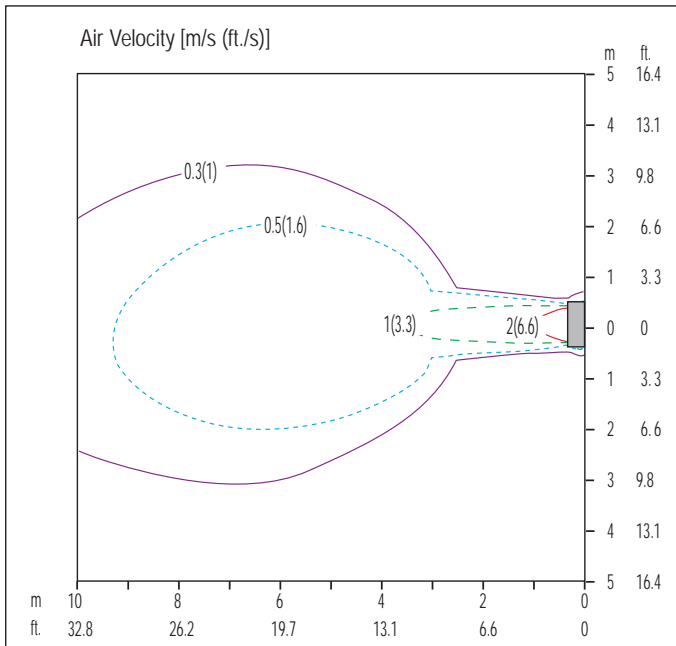

Top View

Discharge Angle: 70°

Vertical Louver: Center

Fan Speed: Power

Air speed 0.3 m/s (1 ft./s) Range: 13.0 m (42.7 ft./s)

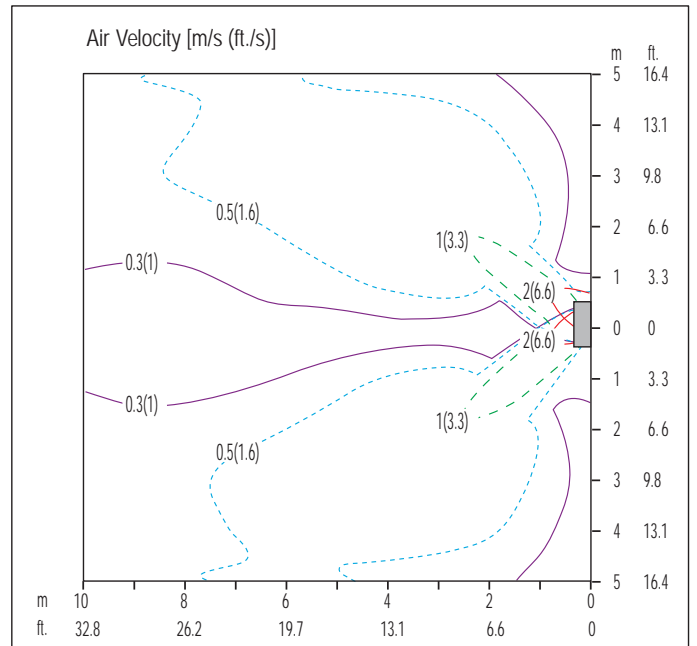

Top View

Discharge Angle: 70°

Vertical Louver: Left & Right

Fan Speed: Power

PERFORMANCE DATA

Air Flow and Temperature Distribution Graphs

LAN090HYV1, continued.

Heating

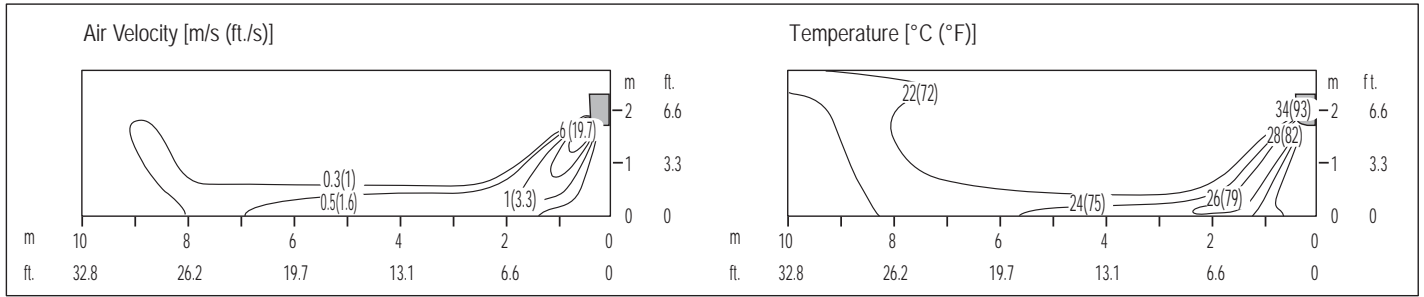

Side View

Discharge Angle: 35°

Vertical Louver: Center

Fan Speed: Power

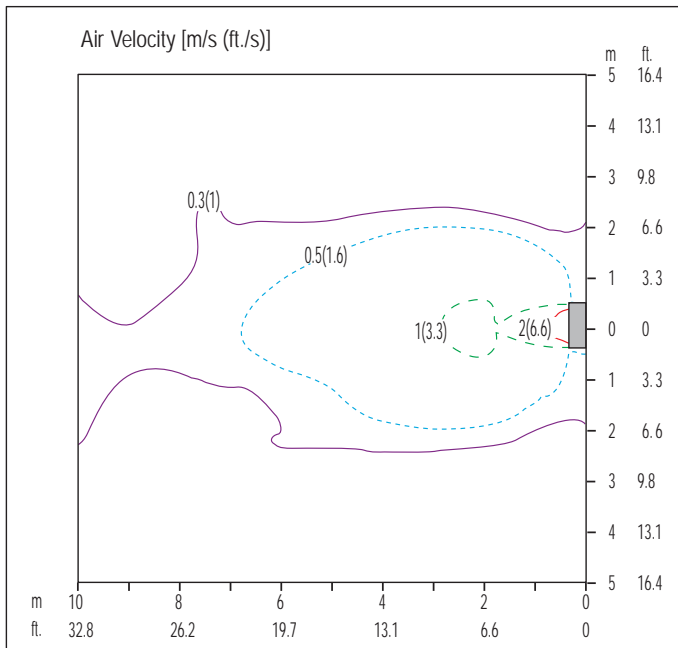

Top View

Discharge Angle: 35°

Vertical Louver: Center

Fan Speed: Power

Air speed 0.3 m/s (1 ft./s) Range: 11.6 m (38.1 ft./s)

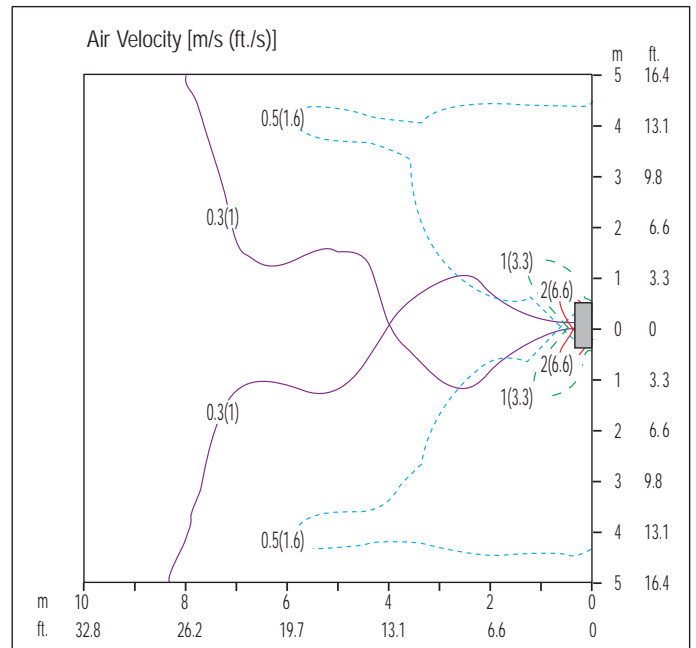

Top View

Discharge Angle: 35°

Vertical Louver: Left & Right

Fan Speed: Power

PERFORMANCE DATA

Air Flow and Temperature Distribution Graphs

LAN120HYV1

Cooling

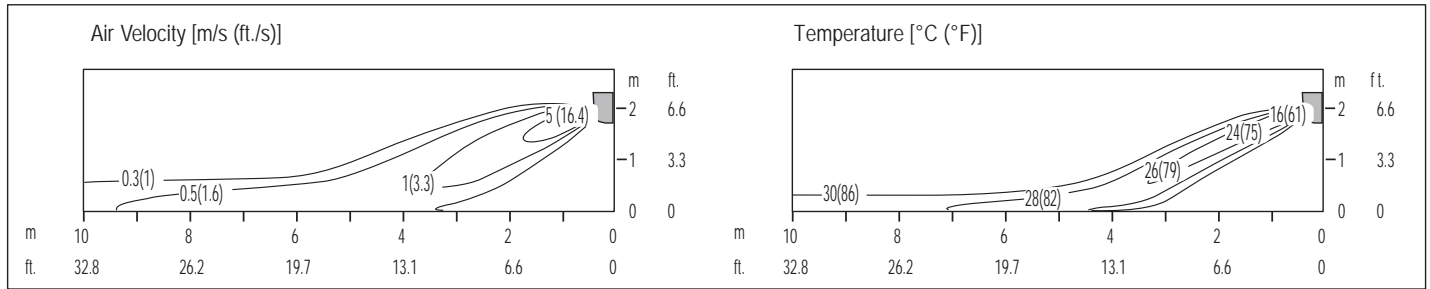

Side View

Discharge Angle: 70°

Vertical Louver: Center

Fan Speed: Power

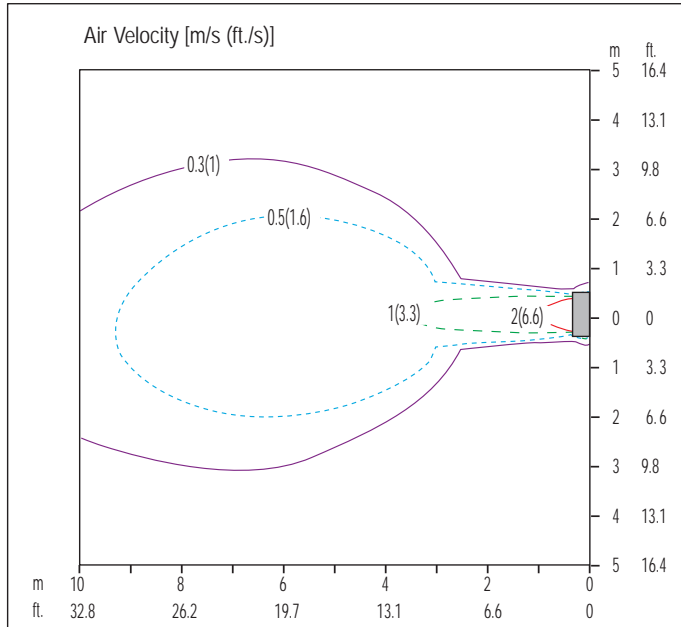

Top View

Discharge Angle: 70°

Vertical Louver: Center

Fan Speed: Power

Air speed 0.3 m/s (1 ft/s) Range: 13.0 m (42.7 ft/s)

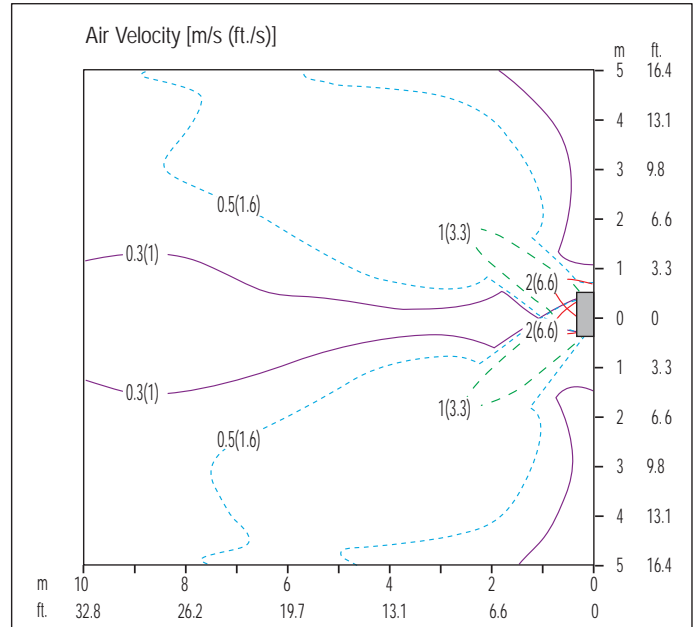

Top View

Discharge Angle: 70°

Vertical Louver: Left & Right

Fan Speed: Power

PERFORMANCE DATA

Air Flow and Temperature Distribution Graphs

LAN120HYV1, continued.

Heating

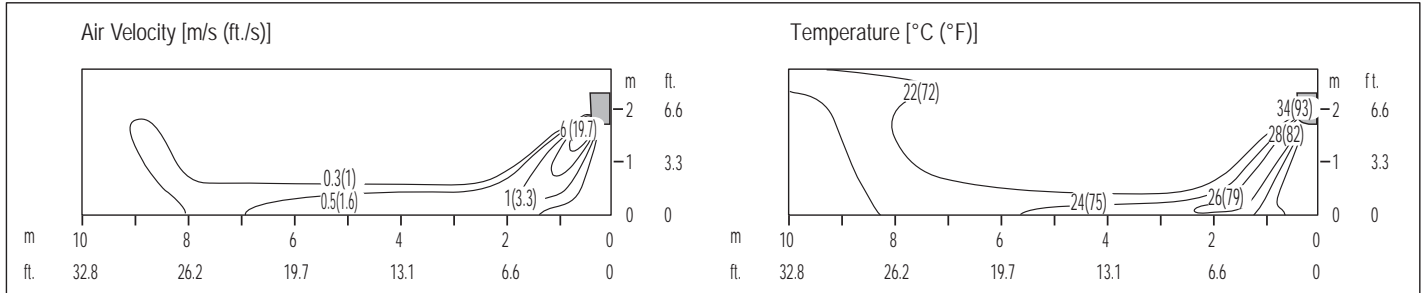

Side View

Discharge Angle: 35°

Vertical Louver: Center

Fan Speed: Power

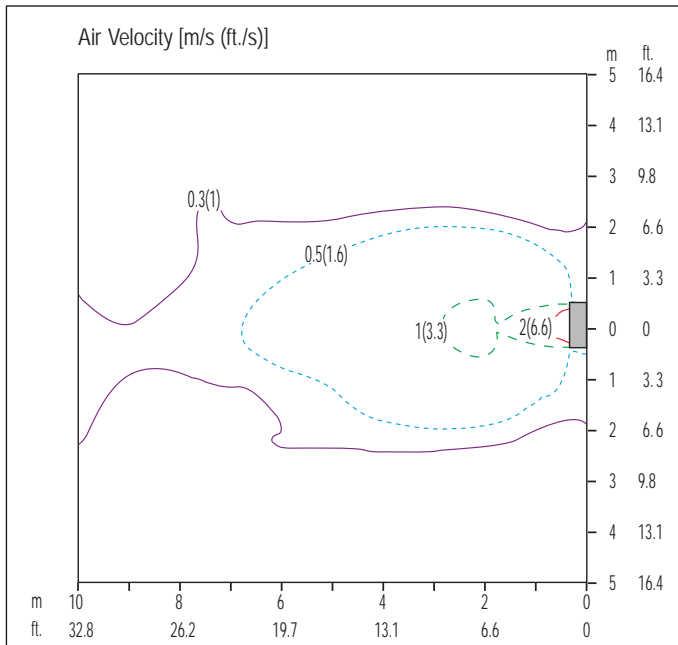

Top View

Discharge Angle: 35°

Vertical Louver: Center

Fan Speed: Power

Air speed 0.3 m/s (1 ft./s) Range: 11.6 m (38.1 ft./s)

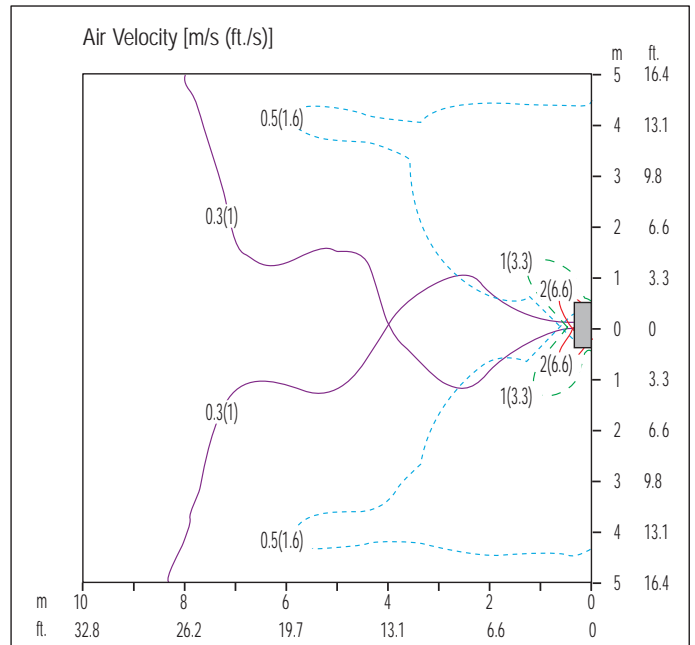

Top View

Discharge Angle: 35°

Vertical Louver: Left & Right

Fan Speed: Power

PERFORMANCE DATA

Air Flow and Temperature Distribution Graphs

LAN180HYV1

Cooling

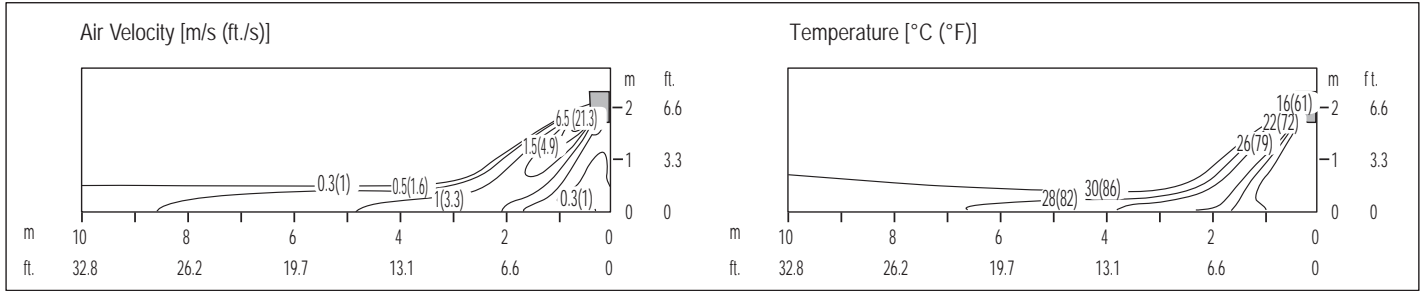

Side View

Discharge Angle: 60°

Vertical Louver: Center

Fan Speed: Power

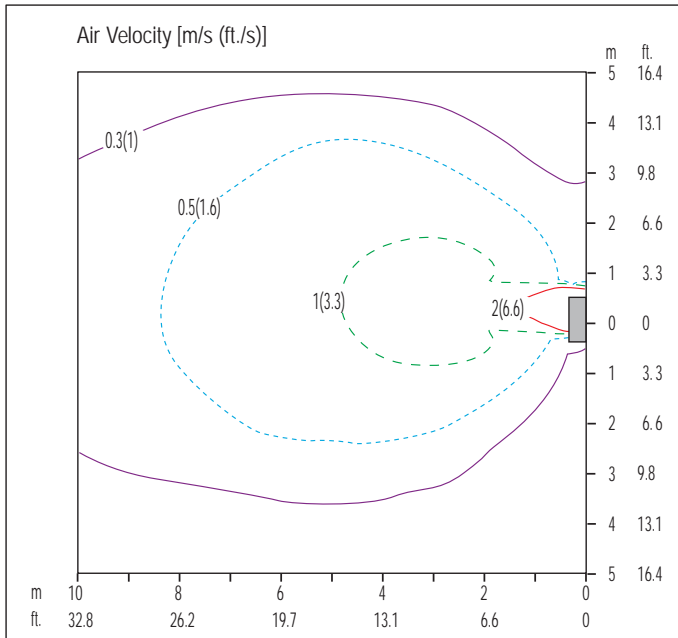

Top View

Discharge Angle: 60°

Vertical Louver: Center

Fan Speed: Power

Air speed 0.3 m/s (1 ft./s) Range: 12.6 m (41.3 ft./s)

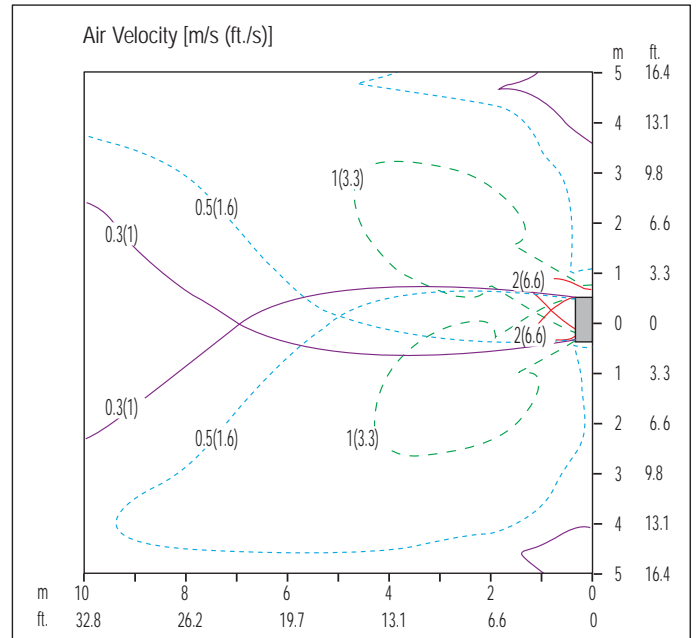

Top View

Discharge Angle: 60°

Vertical Louver: Left & Right

Fan Speed: Power

PERFORMANCE DATA

Air Flow and Temperature Distribution Graphs

LAN180HYV1, continued.

Heating

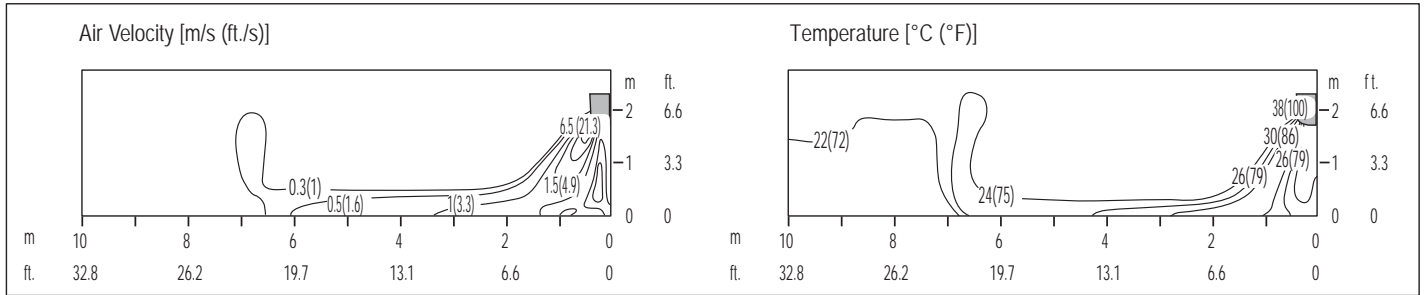

Side View

Discharge Angle: 50°

Vertical Louver: Center

Fan Speed: Power

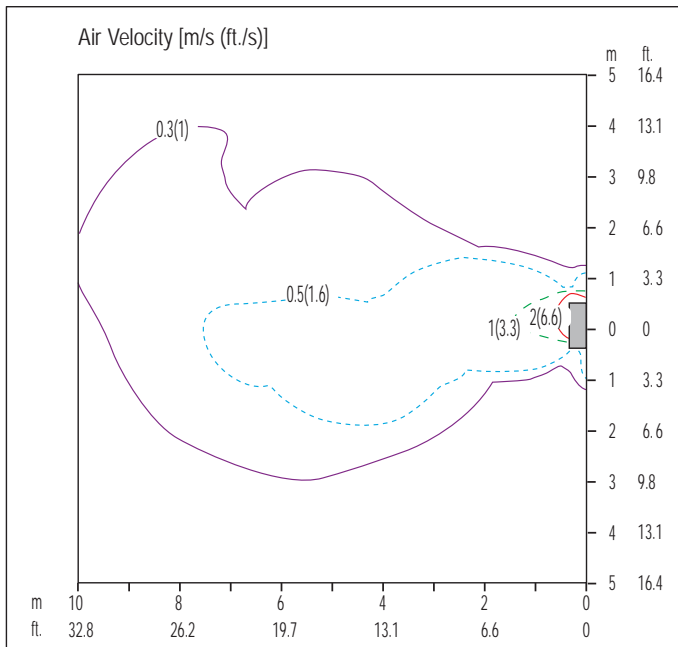

Top View

Discharge Angle: 50°

Vertical Louver: Center

Fan Speed: Power

Air speed 0.3 m/s (1 ft./s) Range: 10.4 m (34.1 ft./s)

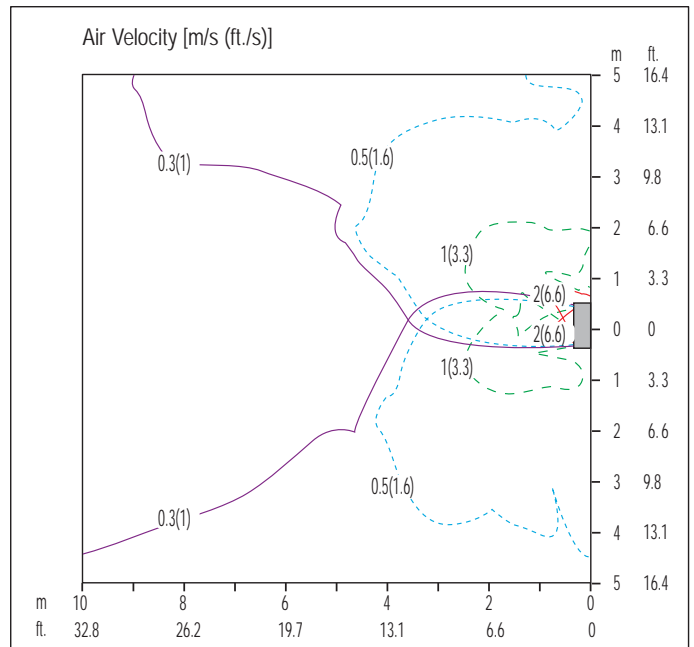

Top View

Discharge Angle: 50°

Vertical Louver: Left & Right

Fan Speed: Power

PERFORMANCE DATA

Air Flow and Temperature Distribution Graphs

LAN240HYV1

Cooling

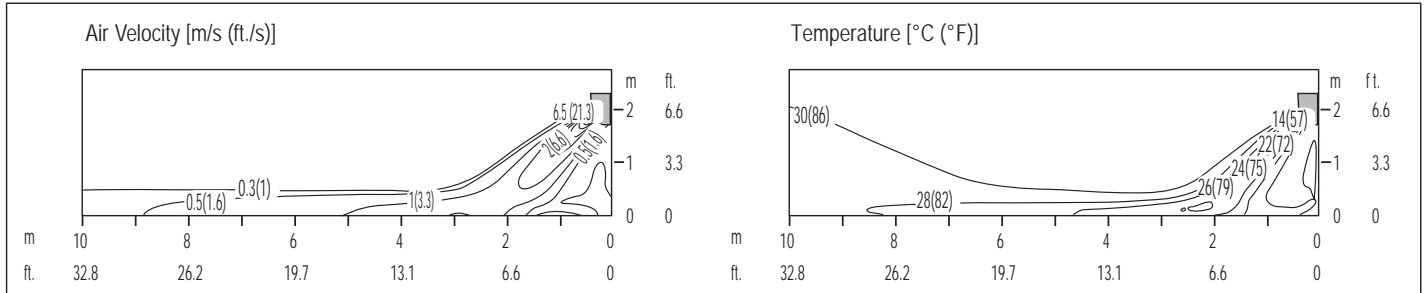

Side View

Discharge Angle: 60°

Vertical Louver: Center

Fan Speed: Power

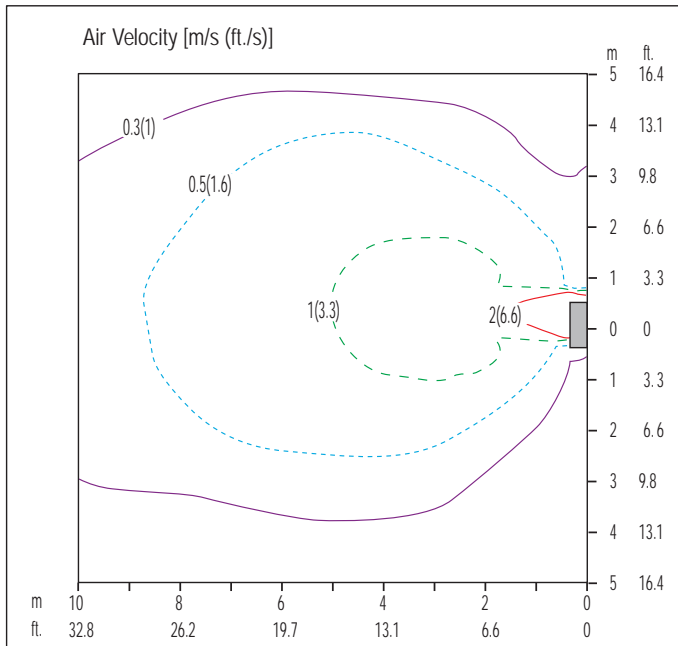

Top View

Discharge Angle: 60°

Vertical Louver: Center

Fan Speed: Power

Air speed 0.3 m/s (1 ft./s) Range: 12.2 m (40.0 ft./s)

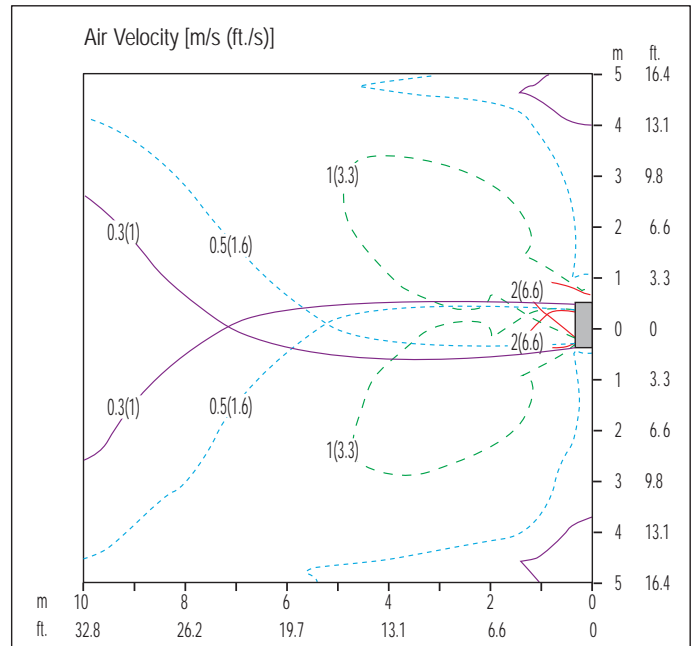

Top View

Discharge Angle: 60°

Vertical Louver: Left & Right

Fan Speed: Power

PERFORMANCE DATA

Air Flow and Temperature Distribution Graphs

LAN240HYV1, continued.

Heating

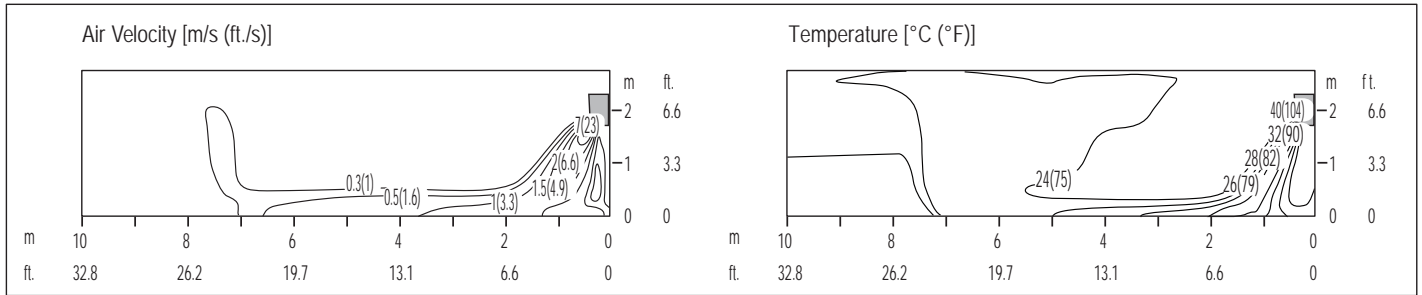

Side View

Discharge Angle: 50°

Vertical Louver: Center

Fan Speed: Power

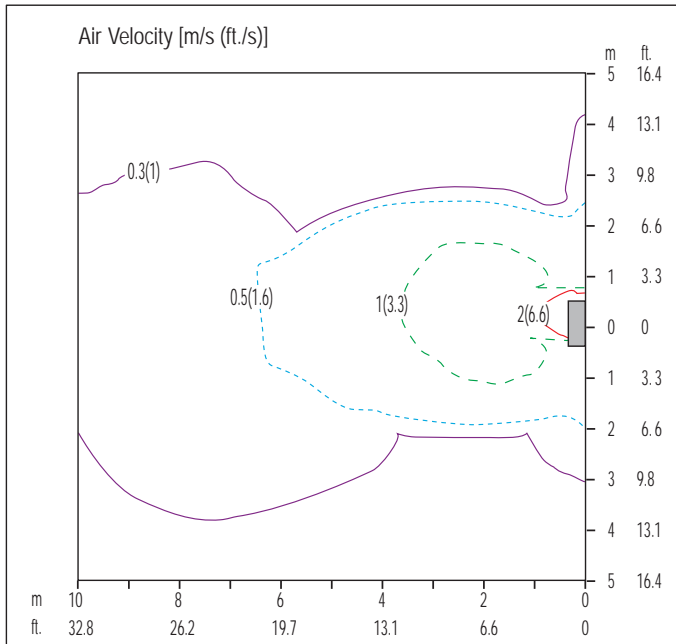

Top View

Discharge Angle: 50°

Vertical Louver: Center

Fan Speed: Power

Air speed 0.3 m/s (1 ft./s) Range: 11.6 m (38.1 ft./s)

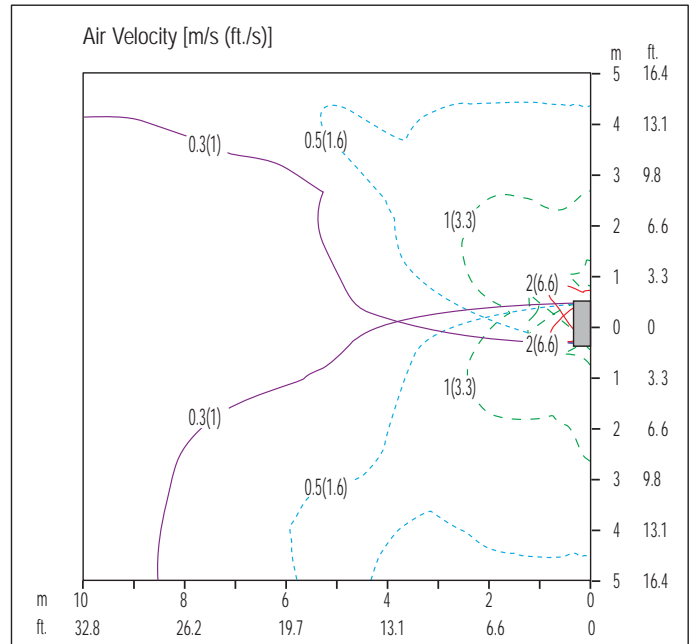

Top View

Discharge Angle: 50°

Vertical Louver: Left & Right

Fan Speed: Power

APPLICATION GUIDELINES

“Equipment Selection Procedure” on page 45

“Building Ventilation Design Guide” on page 46

“Placement Considerations” on page 47

EQUIPMENT SELECTION PROCEDURE

Cooling/Heating Correction Factors

For Single Zone Art Cool Premier systems, calculate the equivalent length of the liquid line from the outdoor unit to the indoor unit. Also, determine the elevation difference of the indoor unit above or below the outdoor unit. Find corresponding cooling or heating capacity correction factors as shown in the table below. Multiply the correction factors by the cooling or heating capacity obtained from the capacity tables using design conditions. The resultant is the NET cooling or heating capacity.

Table 20: Single Zone Art Cool Premier Cooling/Heating % Coefficient Factors.

Model		Main Piping Length										
Indoor Unit	Outdoor Unit	Feet	24.6	32.8	49.2	65.6	82	98.4	114.8	131.2	147.6	164
LAN090HYV1	LAU090HYV1	Cooling	100	98	93	88	-	-	-	-	-	-
		Heating	100	99	96	94	-	-	-	-	-	-
LAN120HYV1	LAU120HYV1	Cooling	100	98	93	88	-	-	-	-	-	-
		Heating	100	99	96	94	-	-	-	-	-	-
LAN180HYV1	LAU180HVV1	Cooling	100	100	100	100	100	100	-	-	-	-
		Heating	100	98	95	91	88	84	-	-	-	-
LAN240HYV1	LAU240HVV1	Cooling	100	100	100	100	100	100	-	-	-	-
		Heating	100	98	95	91	88	84	-	-	-	-

BUILDING VENTILATION DESIGN GUIDE

Building Ventilation Design Guide

ASHRAE 62.1 and local codes specify the minimum volume of outdoor air that must be provided to an occupied space. Outdoor air is required to minimize adverse health effects, and it provides acceptable indoor air quality for building occupants. The three methods of accomplishing this with single zone systems are summarized here.

Note:

Although we believe that these building ventilation methods have been portrayed accurately, none of the methods have been tested, verified, or evaluated by LG Electronics, U.S.A., Inc., In all cases, the designer, installer, and contractor should understand if the suggested method is used, it is used at their own risk. LG Electronics U.S.A., Inc., takes no responsibility and offers no warranty, expressed or implied, in law or in fact, including but not limited to any implied warranty of merchantability or fitness for a particular purpose.

• For a complete copy of Standard 62.1-2010, refer to the American Standard of Heating and Air Conditioning Engineers (ASHRAE) website at www.ashrae.org.

• For more information on how to properly size a ventilation air pretreatment system, refer to the article, "Selecting DOAS Equipment with Reserve Capacity" by John Murphy, published in the ASHRAE Journal, April 2010.

Method 1: Decoupled Dedicated Outdoor Air System (DDOAS)

Provide a separate, dedicated outdoor-air system designed to filter, condition, and dehumidify ventilation air and deliver it directly to the conditioned space through a separate register or grille. This approach requires a separate independent ventilation duct system not associated with single zone systems (Figure 8).

Note:

LG recommends using the DDOAS method in all installations.

Advantages

- May be used with single zone systems.
- The outdoor air unit may supply "neutral" air to the occupant space even when the single zone system indoor unit fan changes speed or cycles on and off. DDOAS controls do not have to be interlocked with the single zone system.
- In lieu of installing localized smaller outside air treatment equipment throughout the building, this method centralizes the ventilation air source making service and filter changes easier and less disruptive for the building occupants.
- Third-party demand control ventilation controls are more readily accommodated.

Disadvantages

- Ceiling space is required to accommodate ductwork between the centralized outdoor air unit and ceiling diffusers.

Note:

Methodology illustrations are for examples only and do not depict actual indoor units for the specific outdoor unit pairing. These are generic illustrations to show ventilation design only.

Figure 8: Decoupled Dedicated Outdoor System Diagram

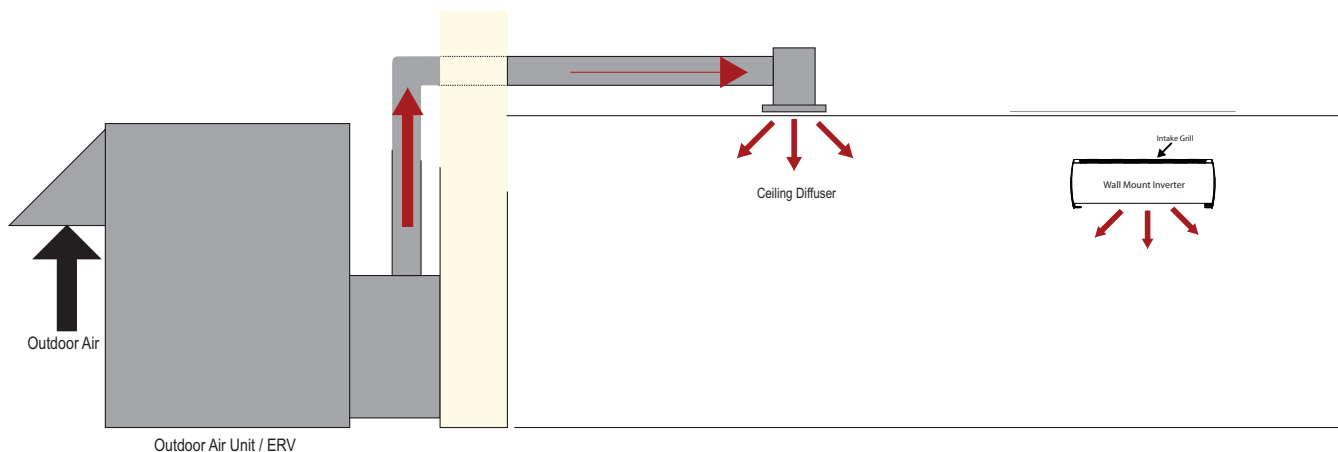

BUILDING VENTILATION DESIGN GUIDE

Method 2: Unconditioned Outdoor Air (Non-Ducted, Natural Ventilation)

Natural ventilation devices, such as operable windows or louvers may be used to ventilate the building when local code permits. The open area of a window or the free area of a louver must meet the minimum percentage of the net occupied floor area (Figure 9).

Advantages

- Occupants control the volume of the ventilation air manually.
- Useful for historic buildings that have no ceiling space available for outdoor air ductwork.
- May be used with single zone systems.

Disadvantages

- In some locations, it may be difficult to control humidity levels when windows are open.
- Thermal comfort levels may be substandard when windows are open.
- Indoor units may have to be oversized to account for the added heating and cooling loads when windows are open.
- Provides outdoor air to perimeter spaces only. Additional mechanical ventilation system may be required to satisfy requirements for interior spaces.
- Outdoor air loads may be difficult to calculate since the quantity of outdoor air is not regulated.
- May affect indoor unit proper operation when open.

Figure 9: Unconditioned Outdoor Air (Non-Ducted)

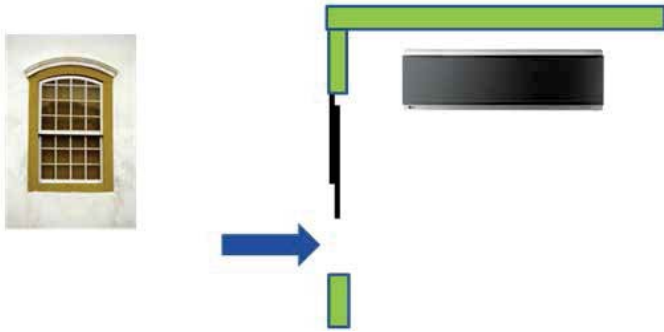

Note:

Methodology illustrations are for examples only and do not depict actual indoor units for the specific outdoor unit pairing. These are generic illustrations to show ventilation design only.

Method 3: Unconditioned Outdoor Air (Non-Ducted, Fan Assisted Ventilation)

When approved by local codes, the fan assisted ventilation method uses exhaust fans to remove air from the building, and outdoor air is drawn into occupied spaces through a wall louver or gravity roof intake hood. Supply fans can also be used to push the outdoor air into the space and building positive pressure will vent the exhaust air through louvers or roof-mounted exhaust hoods. Outdoor air is neither cooled nor heated before entering the building (Figure 10).

Note:

This may result in loss of building pressurization control, increasing infiltration loads with adverse effects.

Advantages

- Outdoor air may be manually controlled by the occupant or automatic controls may be installed to open/close outdoor air dampers or to turn on/off ventilation fans.
- Useful for large open spaces like warehouses, garages, and workshops.
- Outdoor air volume is a known quantity. Air loads may be easier to calculate since fans will regulate the amount of outdoor air.
- May be used with single zone systems.

Disadvantages

- In some locations of the country, it may be difficult to control humidity levels while outdoor air louvers/hoods are opened.
- Thermal comfort levels may be substandard when louvers/hoods are opened.
- Indoor units may have to be oversized to account for the added heating/cooling loads when louvers/hoods are open.
- Hot, cold, and/or humid areas may be present if the outdoor air is not evenly distributed to the different spaces.

Note:

Methodology illustrations are for examples only and do not depict actual indoor units for the specific outdoor unit pairing. These are generic illustrations to show ventilation design only.

Figure 10: Unconditioned Outdoor Air Fan Assisted Ventilation.

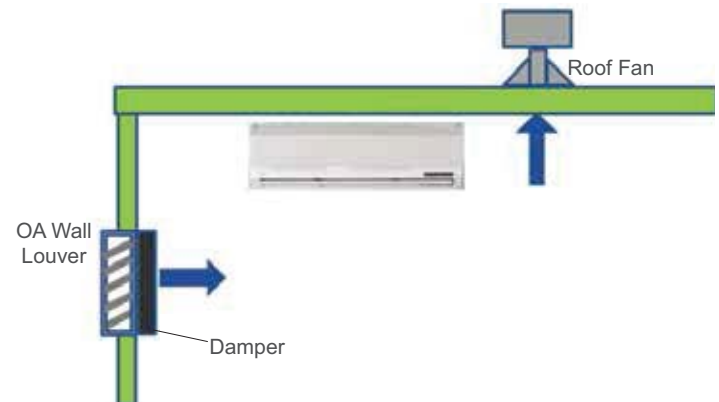

PLACEMENT CONSIDERATIONS

Selecting the Best Location

⚠ DANGER

To avoid the possibility of fire, do not install the unit in an area where combustible gas may generate, flow, stagnate, or leak. Failure to do so will cause serious bodily injury or death.

⚠ WARNING

Install a fence to prevent vermin from crawling into the unit or unauthorized individuals from accessing it. Do not install the unit in a location where acidic solution and spray (sulfur) are often used as this may cause serious bodily injury or death. Do not use the unit in environments where oil, steam, or sulfuric gas are present as this may cause serious bodily injury or death.

Note:

Select a location for installing the outdoor unit that will meet the following conditions:

- Where the unit will not be subjected to direct thermal radiation from other heat sources.
- Where operating sound from the unit will not disturb inhabitants of surrounding buildings.
- Where the unit will not be exposed to direct, strong winds.
- Where there is enough strength to bear the weight of the unit.
- Include space for drainage to ensure condensate flows properly out of the unit when it is in heating mode.
- Include enough space for air flow and for service access.

Note:

To ensure the outdoor unit operates properly, certain measures are required in locations where there is a possibility of heavy snowfall or severe wind chill or cold:

1. Prepare for severe winter wind chills and heavy snowfall, even in areas of the country where these are unusual phenomena.
2. Position the outdoor unit so that its airflow fans are not buried by direct, heavy snowfall. If snow piles up and blocks the airflow, the system may malfunction.
3. Remove any snow that has accumulated by 4 inches or more on the top of the outdoor unit.
4. Place the outdoor unit on a raised platform at least 20 inches higher than the average annual snowfall for the area. In environments where there is a possibility of heavy snow, the frame height must be more than two (2) times the amount of average annual snowfall, and should not exceed the width of the outdoor unit. If the frame width is wider than the outdoor unit, snow may accumulate.
5. Install a snow protection hood.
6. To prevent snow and heavy rain from entering the outdoor unit, install the suction and discharge ducts facing away from direct winds.
7. Additionally, the following conditions should be taken into consideration when the unit operates in defrost mode:
 - If the outdoor unit is installed in a highly humid environment (near an ocean, lake, etc.), ensure that the site is well-ventilated and has a lot of natural light. (Example: Install on a rooftop.)
 - Sidewalks or parking lots near the outdoor unit may accumulate moisture after unit operates in defrost mode that can turn to ice.

Note:

The indoor unit may take longer to provide heat, or heating performance will be reduced in winter if the unit is installed:

1. In a narrow, shady location.
2. Near a location that has a lot of ground moisture.
3. In a highly humid environment.
4. In an area in which condensate does not drain properly.

Ambient Air Conditions

Note:

- Avoid exposing the unit to discharge from boiler stacks, chimneys, steam relief ports, other air conditioning units, kitchen vents, plumbing vents, or substances that may degrade performance or cause damage to the unit.
- When installing multiple outdoor units, avoid placing the units where discharge of one outdoor unit will blow into the inlet side of an adjacent unit.

⚠ WARNING

Avoid exposing the unit to sources of extreme temperature or gases to prevent serious bodily injury.

PLACEMENT CONSIDERATIONS

Indoor Unit Clearance/Outdoor Unit Installation

Indoor Unit Best Location

Note:

Follow recommended best practices when choosing an indoor location for the single zone indoor unit.

- Use a metal detector to locate studs in the walls. Anchor unit following stud location, to prevent damage to the wall.
- Clearance gap between any wall or enclosure and the left or right side of the unit must be greater than 4 inches (Figure 11).
- Minimum clearance of the indoor unit from its top to the ceiling is 5 inches (Figure 11).
- Unit should be at least 6.5 feet from the floor for adequate clearance.

- ⊘ • Keep unit away from any indoor steam or excessive heat.
- No obstacles should be placed around unit.
- Condensation drain (leakage piping) should be routed away from the unit.
- Do not install near doorway.

General Mounting for Outdoor Units

Securely attach the outdoor unit to a condenser pad, base rails, or another mounting platform that is securely anchored to the ground or building structure. Attach the outdoor unit with a bolt and nut on a concrete or rigid mount. See Figure 12. Refer to the applicable installation manual and follow applicable local codes for clearance, mounting, anchor and vibration attenuation requirements.

Note:

All referenced materials are to be field-supplied. Images are not to scale.

Mounting Platform

The underlying structure or foundation must be designed to support the weight of the unit. Avoid placing the unit in a low lying area where water may accumulate. When installing the outdoor unit on the wall, or roof top, anchor the mounting base securely to account for wind, earthquake or vibration.

Tie-Downs and Wind Restraints

The strength of the Single Zone system frame is adequate to be used with field-provided wind restraint tie-downs. The overall tie-down configuration must be approved by a local professional engineer.

Note:

Always refer to local code when designing a wind restraint system.

Snow and Ice Conditions

In climates that experience snow build-up, place the unit on a raised platform to ensure condenser airflow. The raised support platform must be high enough to allow the unit to remain above possible snow drifts. Mount the unit on a field-provided snow stand at a minimum height that is equal to the average annual snowfall plus 20 inches. Design the mounting base to prevent snow accumulation on the platform in front or back of the unit case. If necessary, provide a field fabricated hood to keep snow and ice and/or drifting snow from accumulating on the coil surfaces. Use inlet and discharge duct or hoods to prevent snow or rain from accumulating on the fan inlet and outlet guards. Best practice prevents snow from accumulating on top of the unit. Consider tie-down requirements in case of high winds or where required by local codes.

⚠ CAUTION

When deciding on a location to place the outdoor unit, be sure to choose an area where run-off from defrost will not accumulate and freeze on sidewalks or driveways which may create unsafe conditions.

Figure 11: Single Zone Indoor Unit Clearance Requirements.

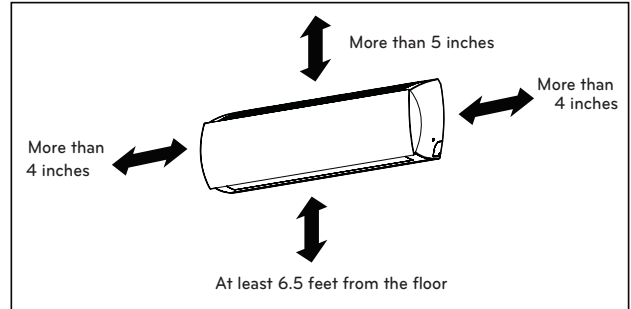

Note:

If the outdoor unit is installed between standard and minimum clearances, capacity decreases approximately 10 to 20%.

Figure 12: Outdoor Unit Mounting Methods.

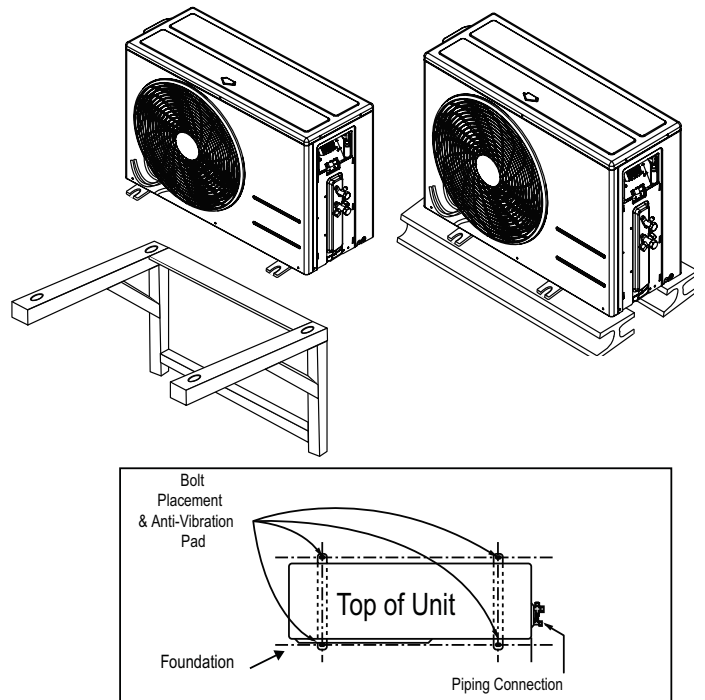

PLACEMENT CONSIDERATIONS

Outdoor Unit Clearances

Minimum Clearance Requirements for Single-Zone Art Cool Premier Systems

Proper clearance for the outdoor unit coil is critical for proper unit operation. When installing the outdoor unit, consider service, inlet and outlet and minimum allowable space requirements as illustrated in the diagrams below.

Specific clearance requirements in the diagram below are for the single-zone Art Cool Premier wall mount systems. Figure 13 shows the overall minimum clearances that must be observed for safe operation and adequate airflow around the outdoor unit.

When placing the outdoor unit under an overhang, awning, sunroof or other "roof-like structure", observe the clearance requirements (as shown in Cases 1 and 2 in Figure 13) for height in relation to the unit. This clearance ensures that heat radiation from the condenser is not restricted around the unit.

Adhere to all clearance requirements if installing the unit on a roof. Be sure to level the unit and ensure that the unit is adequately anchored. Consult local codes for rooftop mounting requirements.

In order to have successful service access to the outdoor unit, see Figure 14 for minimum spacing. When installing multiple outdoor units, see Cases 4 and 5 in Figure 13 for correct spacing requirements.

Note:

If the outdoor unit is installed between standard and minimum clearances, capacity decreases approximately 10%.

Figure 13: Outdoor Unit Service Access and Allowable Clearances Diagram.

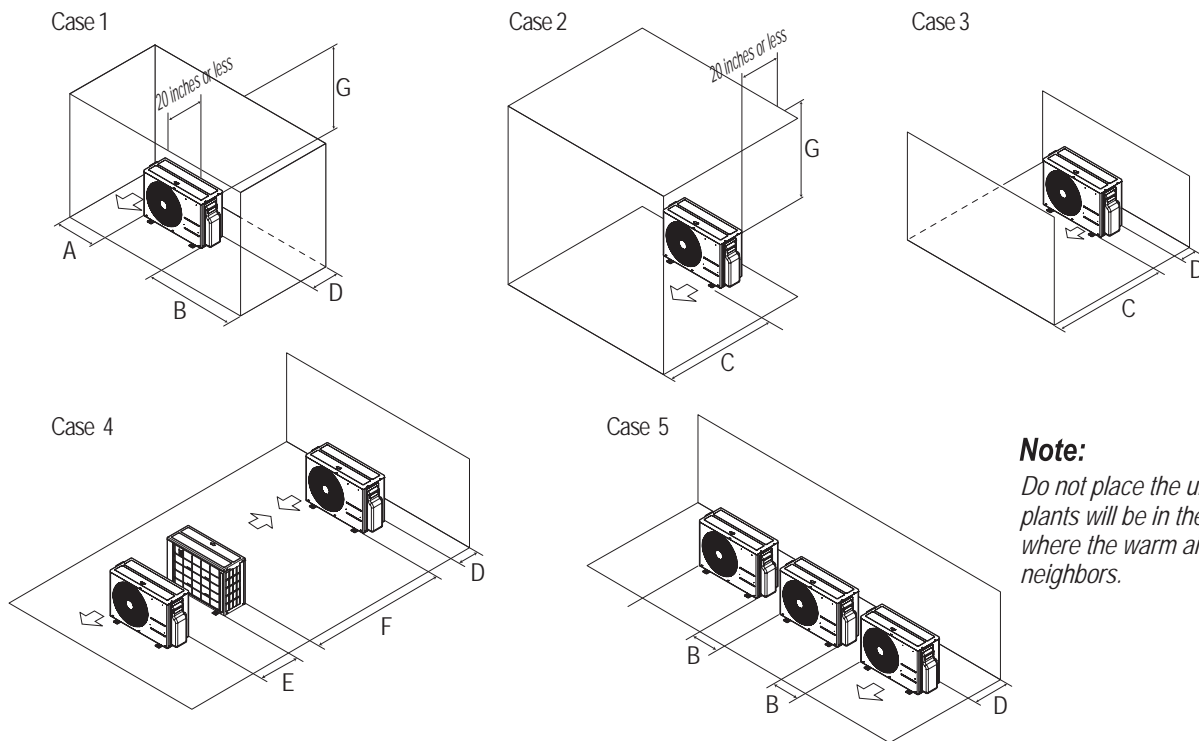

Note:

Do not place the unit where animals and/or plants will be in the path of the warm air, or where the warm air and/or noise will disturb neighbors.

Table 21: Outdoor Unit Service Access and Allowable Clearances Diagram Legend.

Unit: Inch		A	B	C	D	E	F	G
Case 1	Standard	12	24	-	12	-	-	-
	Minimum	4	10	-	4	-	-	40
Case 2	Standard	-	-	20	-	-	-	-
	Minimum	-	-	14	-	-	-	40
Case 3	Standard	-	-	20	12	-	-	-
	Minimum	-	-	14	4	-	-	-
Case 4	Standard	-	-	-	12	24	-	-
	Minimum	-	-	-	4	8	79	-
Case 5	Standard	-	24	-	12	-	-	-
	Minimum	-	10	-	4	-	-	-

REFRIGERANT PIPING DESIGN & LAYOUT BEST PRACTICES

“Refrigerant Piping Design” on page 51

"Selecting Field-Supplied Copper Tubing" on page 51

"Refrigerant Piping System Layout" on page 53

"Electrical Connections" on page 57

“Mechanical Specifications” on page 59

"Acronyms" on page 60

REFRIGERANT PIPING DESIGN

Design Guideline Summary/Selecting Field-Supplied Copper Tubing

Device Connection Limitations

Single-zone systems consist of one outdoor unit and one indoor unit. One of the most critical elements of a single zone system is the refrigerant piping. Table 22 lists pipe length limits that must be followed in the design of a Single Zone Art Cool Premier refrigerant pipe system. Refer to Figure 14 for maximum length and elevation of piping.

Figure 14: Art Cool Premier System Layout.

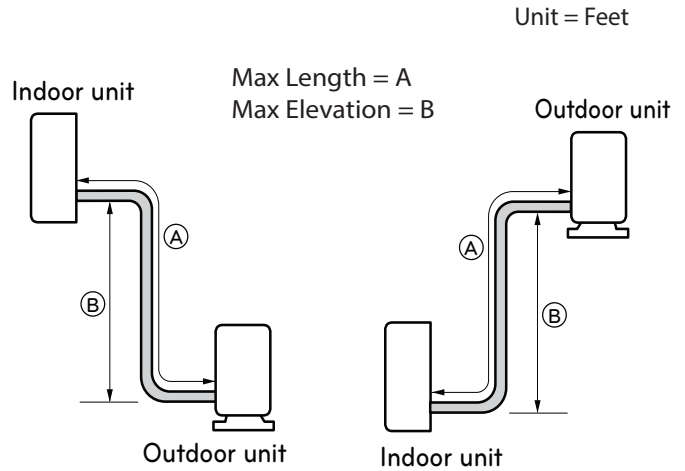

Table 22: Single-Zone Art Cool Premier Wall-Mount Refrigerant Piping System Limitations.

Pipe Length (ELF = Equivalent Length of pipe in Feet)	Longest total equivalent piping length	LA090HYV1	LA120HYV1	LA180HYV1	LA240HYV1
	Shortest total equivalent piping length	65.6 feet	65.6 feet	98.4 feet	98.4 feet
	Distance between fittings and indoor units or outdoor units	≥20 inches	≥20 inches	≥20 inches	≥20 inches
	No Additional Refrigerant	41 feet	41 feet	24.6 feet	24.6 feet
Elevation (All Elevation Limitations are Measured in Actual Feet)	If outdoor unit is above indoor unit	32.8 feet	32.8 feet	65.6 feet	65.6 feet
	If outdoor unit is below indoor unit	32.8 feet	32.8 feet	65.6 feet	65.6 feet
Additional Refrigerant Needed (oz/ft)		0.22	0.22	0.38	0.38

Table 23: Single-Zone Art Cool Premier Wall-Mount Additional Refrigerant by Piping Length.

Model		Refrigerant Piping Length								
Indoor Unit	Outdoor Unit	Feet	24.6	32.8	41	49.2	65.6	82	98.4	114.8
LAN090HYV1	LAU090HYV1	Additional Charge (oz.)	0	0	0	1.8	5.4	-	-	-
LAN120HYV1	LAU120HYV1		0	0	0	1.8	5.4	-	-	-
LAN180HYV1	LAU180HYV1		0	3.1	6.2	9.3	15.6	21.8	28.0	-
LAN240HYV1	LAU240HYV1		0	3.1	6.2	9.3	15.6	21.8	28.0	-

- Capacity is based on standard length; maximum allowance length is based on reliability.
- Equivalent pipe length = actual pipe length + number of bends x 0.3.
- Calculation: X oz. = ((Refrigerant Piping Length) - ((Chargeless Length)) x Additional Refrigerant.

Table 24: Linear Thermal Expansion of Copper Tubing in Inches.

Pipe Length ¹	Fluid Temperature °F																			
	35°	40°	45°	50°	55°	60°	65°	70°	75°	80°	85°	90°	95°	100°	105°	110°	115°	120°	125°	130°
10	0.04	0.04	0.05	0.06	0.06	0.07	0.08	0.08	0.09	0.09	0.10	0.10	0.11	0.11	0.11	0.12	0.13	0.14	0.15	0.15
20	0.08	0.08	0.10	0.12	0.13	0.14	0.15	0.16	0.17	0.18	0.19	0.20	0.21	0.22	0.22	0.23	0.26	0.28	0.29	0.30
30	0.12	0.12	0.15	0.18	0.20	0.21	0.23	0.24	0.26	0.27	0.29	0.30	0.32	0.33	0.32	0.35	0.39	0.42	0.44	0.45
40	0.16	0.16	0.20	0.24	0.26	0.28	0.30	0.32	0.34	0.36	0.38	0.40	0.42	0.44	0.43	0.46	0.52	0.56	0.58	0.60
50	0.20	0.20	0.25	0.30	0.33	0.35	0.38	0.40	0.43	0.45	0.48	0.50	0.53	0.55	0.54	0.58	0.65	0.70	0.73	0.75
60	0.24	0.24	0.30	0.36	0.39	0.42	0.45	0.48	0.51	0.54	0.57	0.60	0.63	0.66	0.65	0.69	0.78	0.84	0.87	0.90

¹Pipe length baseline temperature = 0°F. "Expansion of Carbon, Copper and Stainless Steel Pipe," *The Engineers' Toolbox*, www.engineeringtoolbox.com.

REFRIGERANT PIPING DESIGN

Selecting Field-Supplied Copper Tubing

Figure 15: Coiled Expansion Loops and Offsets.

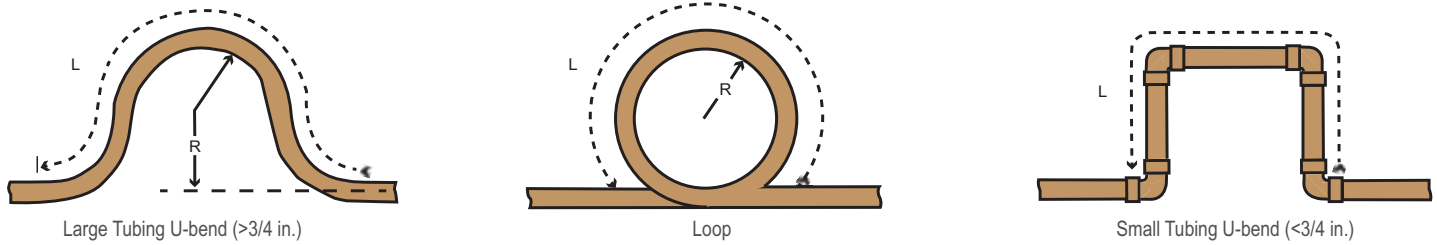

Table 25: Radii of Coiled Expansion Loops and Developed Lengths of Expansion Offsets.

Anticipated Linear Expansion (LE) (inches)		Nominal Tube Size (OD) inches			
		1/4	3/8	1/2	3/4
1/2	R ¹	6	7	8	9
	L ²	38	44	50	59
1	R ¹	9	10	11	13
	L ²	54	63	70	83
1-1/2	R ¹	11	12	14	16
	L ²	66	77	86	101
2	R ¹	12	14	16	19
	L ²	77	89	99	117
2-1/2	R ¹	14	16	18	21
	L ²	86	99	111	131
3	R ¹	15	17	19	23
	L ²	94	109	122	143
3-1/2	R ¹	16	19	21	25
	L ²	102	117	131	155
4	R ¹	17	20	22	26
	L ²	109	126	140	166

¹R = Centerline Length of Pipe.

²L = Centerline Minimum Radius (inches).

Definitions

Physical Pipe Length: Actual length of straight segment(s) of pipe.

Equivalent Pipe Length: Actual length of pipe plus equivalent lengths of long radius elbows, Y-branches, and valves.

Layout Procedure

1. Draft a one-line diagram of the proposed piping system connecting outdoor unit to indoor units. Follow the pipe limitations listed on page 51.
2. Calculate the physical length of each pipe segment and note it on the drawing.
3. Calculate the equivalent pipe length of each pipe segment.

Using Elbows

Field-supplied elbows are allowed as long as they are long radius and designed for use with R410A refrigerant. The designer should be cautious with the quantity and size of fittings used, and must account for the additional pressure losses in equivalent pipe length calculation. The equivalent pipe length of each elbow must be added to each pipe segment. See Table 26 for equivalent lengths.

Table 26: Equivalent Piping Length for Piping Components.

Component	Size (Inches)				
	1/4	3/8	1/2	5/8	3/4
Long Radius Elbow (ft.)	0.5	0.6	0.7	0.8	1.2

Field-Provided Isolation Ball Valves

It is acceptable to install field-supplied ball valves with Schrader ports at the indoor unit. Full-port isolation ball valves with Schrader ports (positioned between valve and indoor unit) rated for use with R410A refrigerant should be used on both the liquid and vapor lines.

If valves are not installed and the indoor unit needs to be removed or repaired, the entire system must be shut down and evacuated. Position valves with a minimum distance of three (3) to six (6) inches of pipe on either side of the valve. Valves must be easily accessible for service. If necessary, install drywall access doors or removable ceiling panels, and position the valves to face the access door or ceiling panel opening. Mount valves with adequate space between them to allow for placement of adequate pipe insulation around the valves. Recommended best practice is to clearly label and document locations of all service valves. The equivalent pipe length of each ball valve must be added to each pipe segment.

INSTALLATION & LAYOUT BEST PRACTICES

Refrigerant Piping System Layout

Obstacles

When an obstacle, such as an I-beam or concrete T, is in the path of the planned refrigerant pipe run, it is best practice to route the pipe over the obstacle. If adequate space is not available to route the insulated pipe over the obstacle, then route the pipe under the obstacle. In either case, it is imperative the horizontal section of pipe above or below the obstacle be a minimum of three (3) times greater than the longest vertical rise (or fall) distance. Refer to Figure 16.

Figure 16: Installing Piping Above and Below an Obstacle.

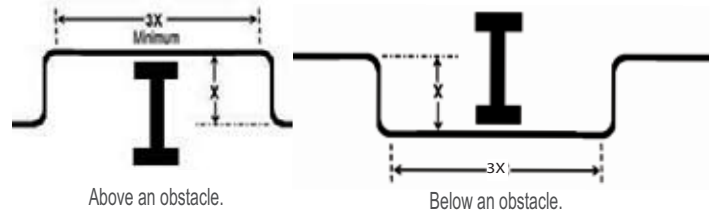

In-line Refrigeration Components

Components such as oil traps, solenoid valves, filter-dryers, sight glasses, tee fittings, and other after-market accessories are not permitted on the refrigerant piping system between the outdoor unit and the indoor unit. Single Zone Art Cool Premier air-source systems are provided with redundant systems that assure oil is properly returned to the compressor. Sight-glasses and solenoid valves may cause vapor to form in the liquid stream. Over time, dryers may deteriorate and introduce debris into the system. The designer and installer verify the refrigerant piping system is free of traps, sagging pipes, sight glasses, filter dryers, etc.

No Pipe Size Substitutions

Using a different size is prohibited and may result in a system malfunction or failure to work at all.

Pipe Supports

A properly installed pipe system should be adequately supported to avoid pipe sagging. Sagging pipes become oil traps that lead to equipment malfunction.

Pipe supports should never touch the pipe wall; supports shall be installed outside (around) the primary pipe insulation jacket (see Figure 17). Insulate the pipe first because pipe supports shall be installed outside (around) the primary pipe insulation jacket. Clevis hangers should be used with shields between the hangers and insulation. Field provided pipe supports must meet local codes. If allowed by code, use fiber straps or split-ring hangers suspended from the ceiling on all-thread rods (fiber straps or split ring hangers can be used as long as they do not compress the pipe insulation). Place a second layer of insulation over the pipe insulation jacket to prevent chafing and compression of the primary insulation within the confines of the support pipe clamp.

A properly installed pipe system will have sufficient supports to avoid pipes from sagging during the life of the system. As necessary, place supports closer for segments where potential sagging could occur. Maximum spacing of pipe supports must meet local codes. If local codes do not specify pipe support spacing, pipe must be supported:

Maximum of five feet (5') on center for straight segments of pipe up to 3/4" outside diameter size.

Wherever the pipe changes direction, place a hanger within twelve (12) inches on one side and within twelve to nineteen (12 to 19) inches of the bend on the other side as shown in Figure 18.

Figure 17: Pipe Hanger Details.

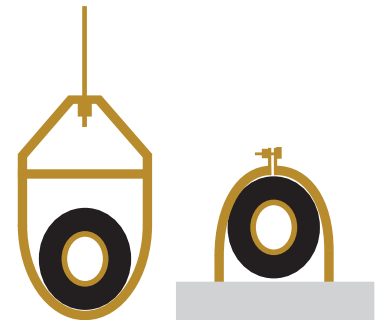

Figure 18: Typical Pipe Support Location—Change in Pipe Direction.

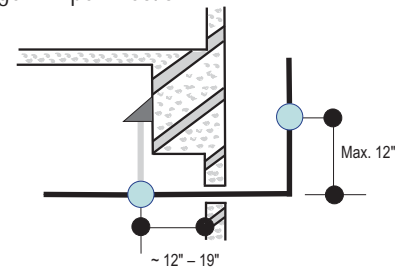
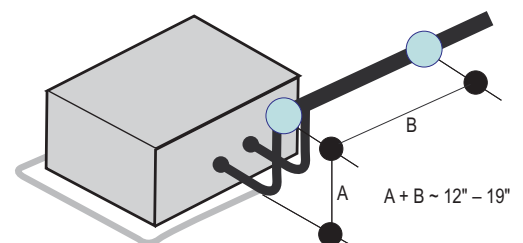

Figure 19: Pipe Support at Indoor Unit.



INSTALLATION & LAYOUT BEST PRACTICES

Refrigerant Piping System Layout

Pipe Sleeves at Penetrations

LG requires that all pipe penetrations through walls, floors, and pipes buried underground be properly insulated and routed through an appropriate wall sleeve of sufficient size to prevent compression of refrigerant pipe insulation and free movement of the pipe within the sleeve. Underground refrigerant pipe shall be routed inside a protective sleeve to prevent insulation deterioration. See Figure 20.

Figure 20: Pipe Sleeve Options.

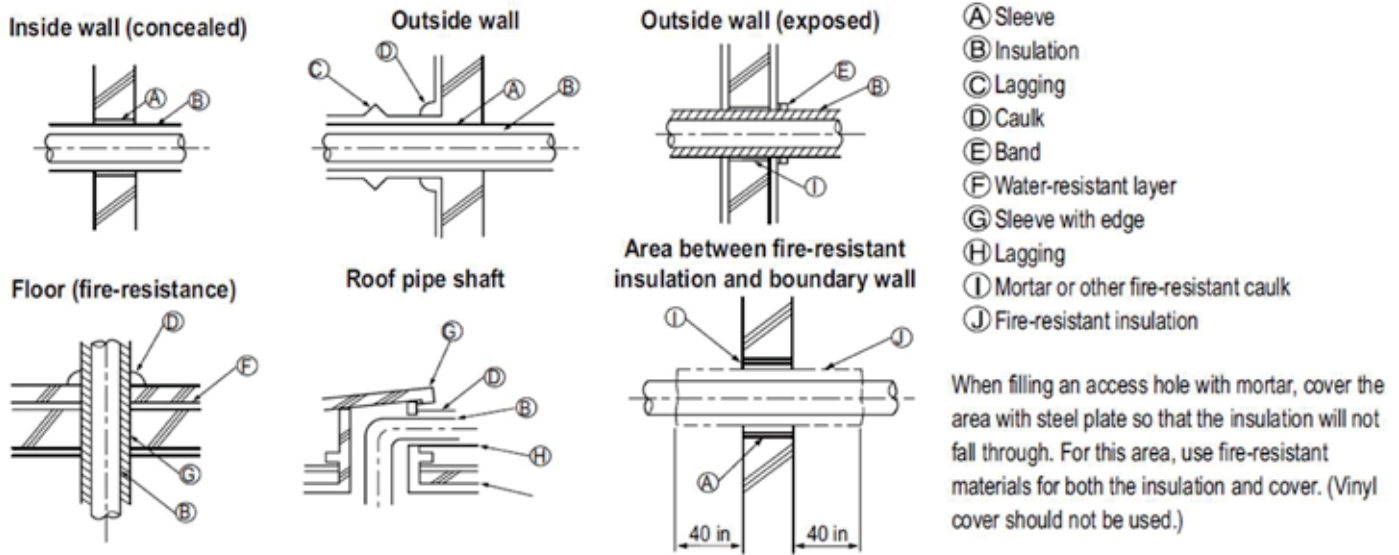

Note:

Diameter of penetrations shall be determined by pipe diameter plus the thickness of the insulation.

Underground Refrigerant Piping

Refrigerant pipe installed underground should be routed inside a vapor tight protective sleeve to prevent insulation deterioration and water infiltration. Refrigerant pipe installed inside underground casing must be continuous without any joints. Underground refrigerant pipe must be located at a level **below the frost line**.

Table 27: Utility Conduit Sizes (Inches).

Liquid Pipe ¹	Vapor Pipe ¹		
	3/8 (1-1/8 ^{2,3})	1/2 (2.0 ^{2,4})	5/8 (2-1/8 ^{2,4})
1/4 (1.0) ⁴	4	4	4
3/8 (1-1/8) ⁴	4	4	4

¹OD pipe diameter in inches; Values in parenthesis () indicate OD of pipe with insulation jacket.

²Diameter of pipe with insulation. Thickness of pipe insulation is typical. Actual required thickness may vary based on surrounding ambient conditions and should be calculated and specified by the design engineer.

³Insulation thickness (value in parenthesis) = 3/8 inch.

⁴Insulation thickness (value in parenthesis) = 3/4 inch.

Figure 21: Typical Arrangement of Refrigerant Pipe and Cable(s) in a Utility Conduit.

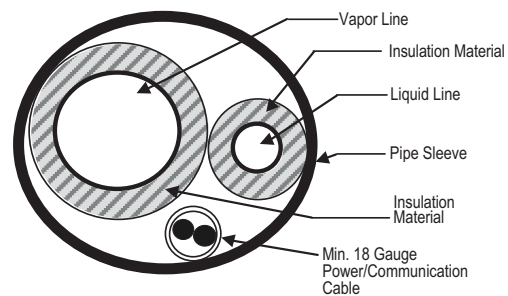

Table 28: Outdoor Unit Refrigerant Pipe Connections (All Brazed Type).

Model	Liquid Conn. (inches)	Vapor Conn. (inches)
LAU090HYV1, LAU120HYV1	1/4	3/8
LAU180HYV1, LAU240HYV1	3/8	5/8

INSTALLATION & LAYOUT BEST PRACTICES

Refrigerant Piping System Layout

Single Zone Art Cool Premier Outdoor Unit Connections

1. Remove the tubing cover from the unit by loosening the fastening screws (Figure 23 and 24).
2. Align the center of the refrigerant pipe and corresponding connection as shown in Figure 22.
3. Place a couple of drops of refrigerant oil on the opening rim of the flare before assembling. Ensure you do not add any contaminants. Tighten the flare nut initially by hand.
4. Finish tightening the flare nut with a torque wrench until the wrench clicks. See Figures 25 and 26.

Figure 22: Pipe Attachment.

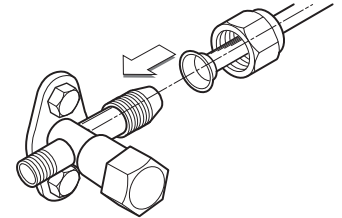

Table 29: Torque Wrench Tightening.

Outside Diameter (Inches)	Torque (Lbs.-ft)
1/4	13-18
3/8	24.6-30.4
1/2	39.8-47.7
5/8	45.6-59.3
3/4	71.6-87.5

Note:

When tightening the flare nut with a torque wrench, ensure the direction for tightening follows the arrow on the wrench.

Figure 23: LAU090HYV1/LSU120HYV1 Outdoor Unit Connection Cover Removal.

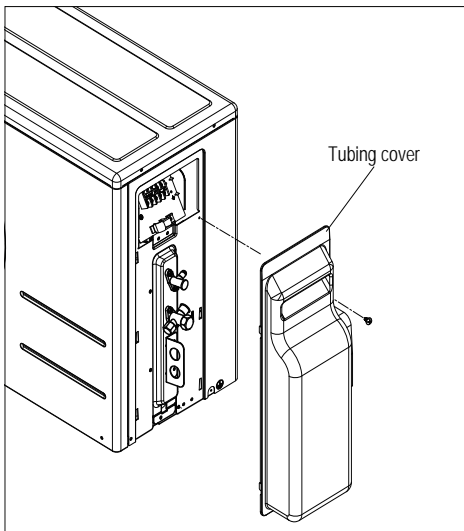

Figure 24: LAU180HYV1/LSU240HYV1 Outdoor Unit Connection Cover Removal.

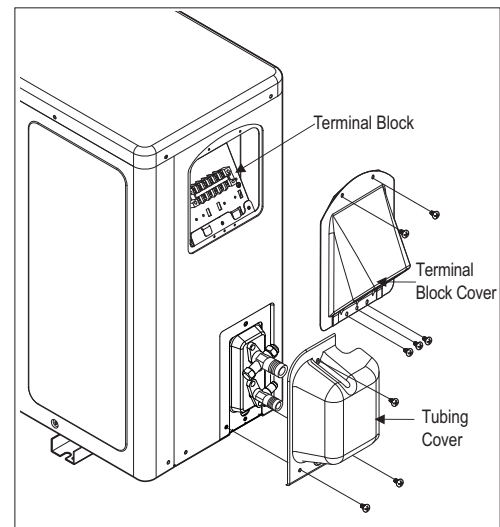

Figure 25: LAU090HYV1/LSU120HYV1 Outdoor Unit Piping Connection.

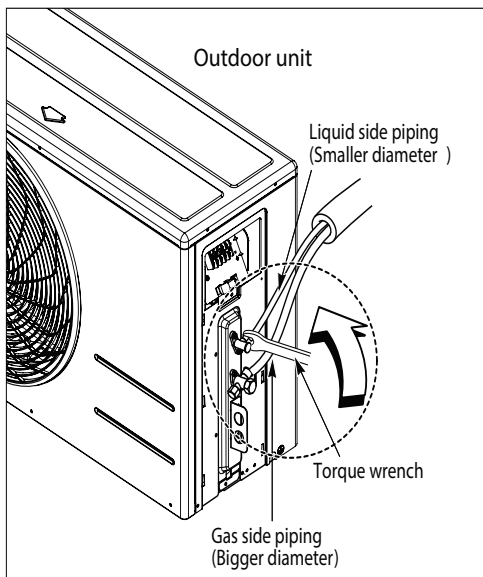
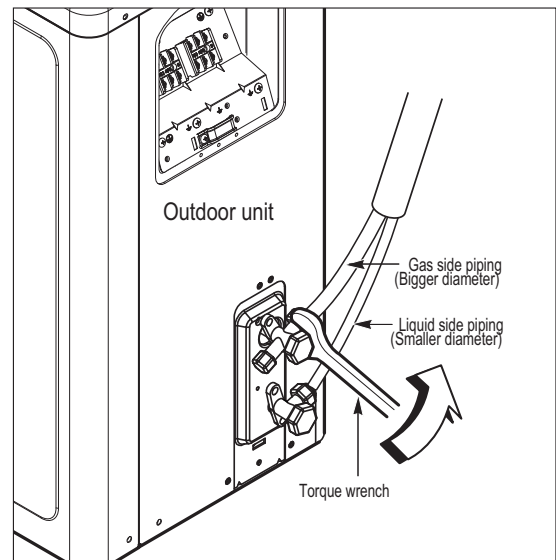

Figure 26: LAU180HYV1/LSU240HYV1 Outdoor Unit Piping Connection.



INSTALLATION & LAYOUT BEST PRACTICES

Refrigerant Piping System Layout

Installation of Refrigerant Piping / Brazing Practices

Note:

It is imperative to keep the piping system free of contaminants and debris such as copper burrs, slag, or carbon dust during installation.

All joints are brazed in the field. Single Zone Art Cool Premier refrigeration system components contain very small capillary tubes, small orifices, electronic expansion valves, oil separators, and heat exchangers that can easily become blocked. Proper system operation depends on the installer using best practices and utmost care while assembling the piping system.

- While brazing, use a dry nitrogen purge operating at a minimum pressure of three (3) psig and maintain a steady flow.
- Blow clean all pipe sections with dry nitrogen prior to assembly.
- Use a tubing cutter, do not use a saw to cut pipe. De-burr and clean all cuts before assembly.
- Store pipe stock in a dry place. Keep pipe capped and clean.
- Use adapters to assemble different sizes of pipe.
- Do not use flux, soft solder, or anti-oxidant agents.
- Use a 15% silver phosphorous copper brazing alloy to avoid overheating and produce good flow.
- Protect isolation valves, electronic expansion valves, and other heat-sensitive control components from excessive heat with a wet rag or a heat barrier spray product.

Figure 27: Refrigerant Pipe Brazing.

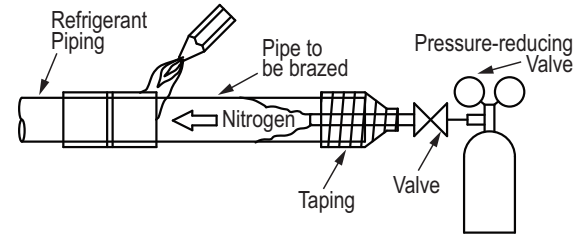

Refrigerant Piping System Insulation

All refrigerant piping, field-provided isolation ball valves, service valves, and long radius elbows shall be completely insulated using closed cell pipe insulation. The liquid and vapor lines must be insulated separately.

To prevent heat loss/heat gain through the refrigerant piping, all refrigerant piping including liquid lines and vapor lines shall be insulated separately. Insulation shall be a minimum 1/2" thick, and thickness may need to be increased based on ambient conditions and local codes.

All insulation joints shall be glued with no air gaps. Insulation material must fit snugly against the refrigeration pipe with no air space between it and the pipe. Insulation passing through pipe hangers, inside conduit, and/or sleeves must not be compressed. Protect insulation inside hangers and supports with a second layer. All pipe insulation exposed to the sun and outdoor elements shall be properly protected with PVC, aluminum vapor barrier, or alternatively placed in a weather-resistant enclosure such as a pipe rack with a top cover, and meet local codes.

The design engineer should perform calculations to determine if the factory-supplied insulation jackets are sufficient to meet local codes and avoid sweating. Add additional insulation if necessary. Mark all pipes at the point where the insulation jacket ends. Remove the jacket. Install field-provided insulation on the run-out and main truck pipes first. Peel the adhesive glue protector slip from the insulation jacket and install the clam-shell jacket over the fitting.

Charging

Each outdoor unit is factory charged (nameplate charge) for the evaporator as well as a standard 25 ft line. Any time a line set is used longer than the standard 25 ft line set length, the refrigerant charge has to be adjusted.

You must adjust the charge based on how many feet of piping are added based on 0.22 oz. of R410A per foot. The factory charge accommodates pipe lengths up to the standard length without requiring refrigerant removal.

Note:

If you are uncertain of the unit charge, reclaim, evacuate and weigh in the correct charge using the unit nameplate (capacity) charge adjusting for line sets longer than 24.6 or 41 ft. This will prevent any interruptions to the functioning of the unit and possible damage.

Example: A 50 ft line set is used --
 $9 \text{ additional feet} \times 0.22 \text{ oz per ft} = \text{Add } 1.98 \text{ oz of R410A}$

Table 30: Charging Capacity.

Capacity (Btu/h)/Model	Pipe Size		Standard Length (ft)	Max. Elevation (ft)	Max. Length (ft)	Min. Length (ft)	Additional Refrigerant (oz/ft)
	Vapor	Liquid					
9k, 12k HYV1	3/8	1/4	41	32.8	65.6	6.6	0.22
18k, 24k HYV1	5/8	3/8	24.6	20	98.4	9.8	0.38

Outdoor Electrical Connection

1. Remove the control cover from the unit by loosening the fastening screw (Figures 28 and 29).
2. Take off the caps on the conduit panel.
3. Connect both the power supply and low voltage lines to the corresponding terminals on the terminal block (see Figures 31 and 32).
4. Be sure to ground the unit by following local codes.
5. Allow for enough length (add several inches) for each wiring.
6. Secure the cable with a cord clamp.
7. Secure conduit tubes with lock nuts.
8. Reattach the control cover to the original position with the fastening screw.

⚠ WARNING

- Separately wire the high and low voltage lines. There is a risk of electric shock, physical injury, or death.
- Use heat-proof electrical wire capable of withstanding temperatures up to 167°F to avoid wiring malfunction and electrical shock, which may cause physical injury or death.
- Ensure you connect the wire firmly. Loose wiring may cause unit malfunction, the wires to burnout or the terminal to overheat and catch fire. There is a risk of electric shock, physical injury or death.
- Use outdoor and waterproof connection cable rated up to 300V for the connection between the indoor and outdoor unit to avoid electrical shock, which may cause physical injury or death.

Figure 28: LAU090HYV1/ LAU120HYV1 Outdoor Unit Electrical Connection.

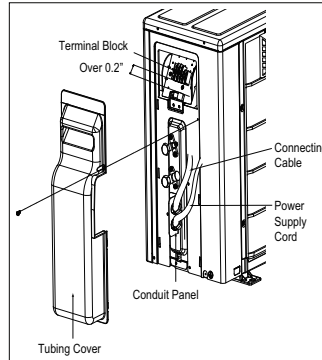

Figure 29: LAU180HYV1/ LAU240HYV1 Outdoor Unit Electrical Connection.

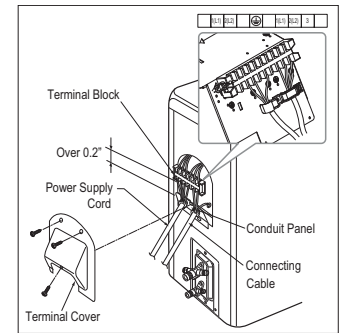

Figure 30: Circuit Breaker.

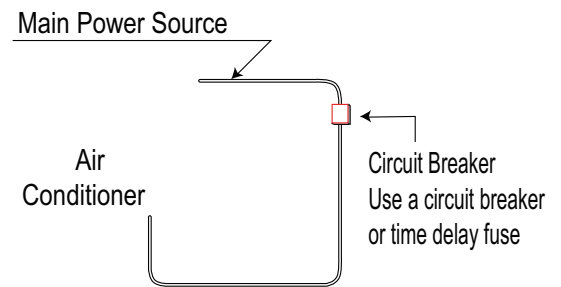

Figure 31: LAU090HYV1/LAU120HYV1 Outdoor Unit Electrical Connection.

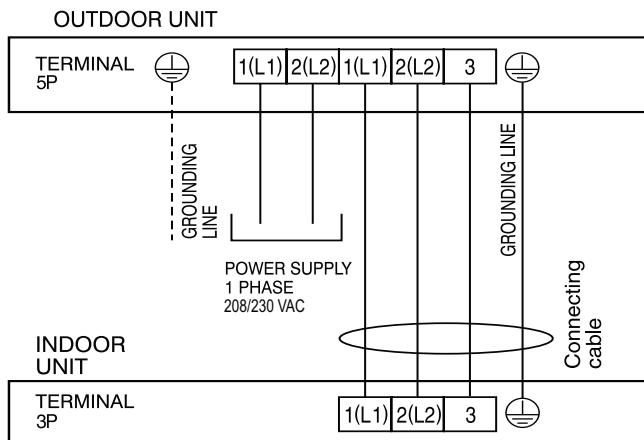
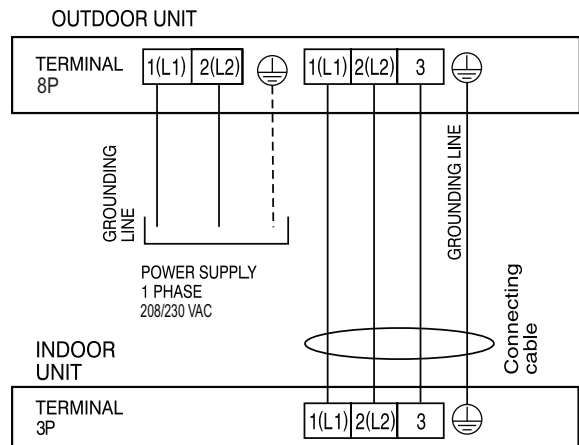

Figure 32: LAU180HYV1/LAU240HYV1 Outdoor Unit Electrical Connection.



Note:

- Separately wire the high and low voltage lines to avoid damage to unit.
- Local codes may require field-installed disconnect switches from outdoor unit to indoor unit.
- Use heat-proof electrical wire capable of withstanding temperatures up to 167°F to avoid damage to unit.
- Always use a circuit breaker or time delay fuse when connecting electrical wiring to the unit.
- Ensure you connect the wire firmly. Loose wiring may cause unit malfunction, the wires to burnout or the terminal to overheat and catch fire. There is a risk of equipment malfunction or property damage.
- Use outdoor and waterproof connection cable rated up to 300V for the connection between the indoor and outdoor unit to avoid damage to the unit.
- Comply with local codes while running wire from the indoor unit to the outdoor unit.
- Do not allow wire to touch refrigerant tubing, the compressor or any moving parts since it can lead to mechanical failure.

TECHNICAL DATA

“Mechanical Specifications” on page 59

“Acronyms” on page 60

MECHANICAL SPECIFICATIONS

Single Zone Art Cool Premier

General

LG Single Zone Art Cool Premier systems are comprised of a single outdoor unit connected to a single indoor unit with a single refrigerant circuit.

These single zone systems can operate in either cooling or heating mode. These systems are capable of changing mode within a maximum time of three (3) minutes to ensure indoor temperature can be properly maintained.

LG Single Zone Art Cool Premier systems are manufactured in a facility registered to ISO 9001 and ISO 14001, which is a set of standards applying to environmental protection set by the International Organization for Standardization (ISO). The units are listed by Intertek Electrical Testing Laboratories (ETL) and bear the ETL label. Wiring in these units are in accordance with the National Electrical Code (NEC).

Temperature Ranges

Outdoor Unit

Operating ranges for Outdoor units of 14°F to 118°F DB for cooling; -13°F to 65°F WB for heating.

Indoor Unit

Operating ranges for Indoor Units of 53°F to 75°F WB for cooling; 60°F to 86°F DB for heating.

(Installing an optional Low Ambient Wind Baffle Kit will allow operation down to 0°F in cooling mode for these single zone systems.)

Casing / Frame

Outdoor unit is constructed with pre-coated metal (PCM).

Indoor unit is constructed of heavy duty Acrylonitrile Butadiene Styrene (ABS) and High Impact Polystyrene (HIPS) plastic.

Refrigerant System

The refrigeration system consists of a single refrigeration circuit and uses R410A refrigerant.

The outdoor unit is provided with factory installed components, including a refrigerant strainer, check valves, oil separator, accumulator, four-way reversing valve, electronic controlled expansion valve (EEV), high and low side charging ports, service valves, and interconnecting piping.

Refrigeration Oil Control

Heat Pump outdoor units have a centrifugal oil separator and controls to ensure sufficient oil supply is maintained, and that oil does not travel with the refrigerant.

Compressors

The outdoor unit is equipped with one hermetic digitally controlled inverter driven twin-rotary compressor to modulate capacity (modulation in 1 Hz increments).

Frequency ranges for the outdoor units are as follows:

LAU090HYV1, LAU120HYV1 - 10-115 Hz
LAU180HYV1, LAU240HYV1 - 10-115 Hz

Overcurrent protection and vibration isolation are integrated with the compressor.

Outdoor Unit Coil

Heat Pump outdoor unit coils are made of a nonferrous construction with louvered fins on copper tubing, and are protected with an integral coil guard. Coil fins have a factory applied corrosion resistant GoldFin™ material with hydrophilic coating.

Fans and Motors

The outdoor unit includes one direct fan drive, variable speed propeller type fan.

The Brushless Digitally Controlled (BLDC) fan motor shall have inherent protection, permanently lubricated bearings, and variable speed with a maximum speed up to 950 rpm. Raised guards are provided to limit contact with moving parts.

The outdoor unit has horizontal discharge airflow.

Electrical

These units are available in 208-230V, 60 Hz, 1-phase power supply. These units are capable of operating within voltage limits of ±10% rated voltage, and include overcurrent protection.

Controls

These units are factory wired with necessary electrical control components, integral microprocessors, printed circuit boards, thermistors, sensors, terminal blocks, and lugs for power wiring.

Microprocessor-based algorithms provide component protection, soft-start capability, refrigeration system pressure, temperature, defrost, and ambient control.

ACRONYMS

Table 31: Table of Acronyms.

ABS	Acrylonitrile Butadiene Styrene	IDU	Indoor Unit
AC	Air Conditioner	ISO	International Organization for Standardization
ACP	Advanced Control Platform	kW	Kilo Watts
ASHRAE	American Society of Heating, Refrigeration, and Air Conditioning	LED	Light Emitting Diode
AWG	American Wire Gauge	MBh	Thousands BTUs per hour
BLDC	Brushless Digitally Controlled/Direct	MCA	Maximum Circuit Ampacity
Btu/h	British Thermal Units per hour	MOP	Maximum Overcurrent Protection
BUS	Binary Unit System	MSC	Maximum Starting Current
CFM	Cubic Feet per Minute	NC	Noise Criterion (regarding Sound Pressure Levels)
COP	Coefficient Of Performance	NEC	National Electrical Code
CR	Combination Ratio	ODU	Outdoor Unit
DB	Dry Bulb	PCB	Printed Circuit Board
dB(A)	Decibels with "A" frequency weighting	PCM	Pre-Coated Metal
DDOAS	Decoupled Dedicated Outdoor Air	PDI	Power Distribution Indicator
DI	Digital Input	PI	Power Input
DO	Digital Output	PTAC	Packaged Terminal Air Conditioner
DPST	Double-Pole Single-Throw (switch)	PVC	Polyvinyl Chloride
EEV	Electronic Expansion Valve	SW or S/W	Switch
ELF	Equivalent Length in Feet	USB	Universal Serial BUS
ESP	External Static Pressure	VAC	Voltage Alternating Current
ETL	Electronic Testing Laboratories	VAV	Variable Air Volume
HIPS	High Impact Polystyrene	VRF	Variable Refrigerant Flow
H/M/L	High/Medium/Low	WB	Wet Bulb
HVAC	Heating, Ventilation and Air Conditioning		

Inverter

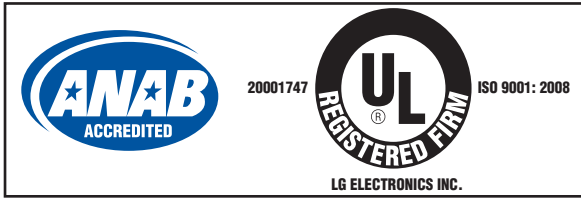

LG Electronics, U.S.A., Inc.
Commercial Air Conditioning Division
4300 North Point Parkway
Alpharetta, Georgia 30022
www.lg-vrf.com

LG Electronics Commercial Products Support
1-888-865-3026 USA
Follow the prompts for commercial A/C products.

EM_SZ_ArtCoolPremier_ALL_12_15
Supersedes: EM-SZ-ArtCoolPremier-ALL-3-15
EM-SZ-ArtCoolPremier-ALL-09-14