

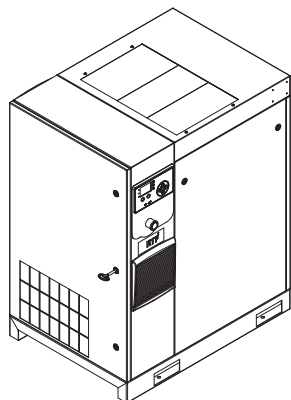

Contact-Cooled Rotary Screw Air Compressor

R4-11 kW



Product Information



Save These Instructions



CONTENTS

ABOUT THIS MANUAL	3	HOME FOLDER	19
SAFETY	3	OPERATOR SETTINGS FOLDER	20
TRANSPORTATION/ RECEIPT/ HANDLING	3	EVENTS FOLDER	21
TRANSPORTATION	3	WARNING EVENTS LIST	21
RECEIPT	4	TRIP EVENTS LIST	22
UNPACKING AND HANDLING	4	START INHIBIT LIST	22
LONG TERM STORAGE	4	TRIP HISTORY	22
INSTALLATION	5	MAINTENANCE FOLDER	23
LOCATION IN PLANT	5	GENERAL SETTINGS FOLDER	23
DISCHARGE AND CONDENSATE PIPING	5	INTEGRAL SEQUENCING FOLDER	24
GENERAL ELECTRICAL	6	STATUS FOLDER	26
INTEGRATED DRYER	6	FACTORY SETTINGS FOLDER	27
ENVIRONMENTAL LIMITS	6	MODBUS CONNECTION AND CONTROL	28
GENERAL INFORMATION	7	CONNECTION TO THE MODBUS NETWORK	28
OPERATING INSTRUCTIONS (GENERAL)	8	RS-485 NETWORK	28
BASIC OPERATION	8	MODBUS ADDRESS SELECTION	28
PRIOR TO STARTING	8	MODBUS MASTER SETTINGS	28
INITIAL CHECK SEQUENCE	8	MODBUS TABLE	
START SEQUENCE	8	R4 to 37 kW FIXED SPEED MODBUS TABLE	36
STOP SEQUENCE	8	R5.5 to 37 kW VARIABLE SPEED MODBUS TABLE	39
EMERGENCY STOPPING	8	X-SERIES SYSTEM CONTROLS CONNECTION	42
RESTARTING AFTER EMERGENCY STOPPING	8	RS-485 NETWORK	42
OPERATING INSTRUCTIONS (XE-70M CONTROLLER)	9	RS-485 ADDRESS SELECTION	42
USER INTERFACE	9	ENABLING SYSTEM CONTROL CAPABILITIES	42
LED STATUS ICONS	9	OPERATING INSTRUCTIONS (XE-50M CONTROLLER)	43
COMMAND KEYS	9	COMMAND KEYS	43
NAVIGATION KEYS	9	DISPLAY LAYOUT	43
DISPLAY LAYOUT	9	USER DISPLAY	43
FOLDER NAVIGATION AND ICONS	10	STATUS DISPLAY	43
PAGE NAVIGATION	10	FAULT CONDITIONS	44
ACCESSING PARAMETERS	10	SERVICE DUE COUNTDOWN TIMER	44
DASHBOARD ICONS	10	MENU ROUTINE	44
DASHBOARD STATUS MESSAGES	10	OPERATIONAL MENU	44
FIXED SPEED COMPRESSOR	11	FAULT CODES	45
HOME FOLDER	11	X-SERIES SYSTEM CONTROLS CONNECTION	45
OPERATOR SETTINGS FOLDER	12	ENABLING SYSTEM CONTROL CAPABILITIES	45
EVENTS FOLDER	13	OPERATING INSTRUCTIONS FOR INTEGRATED DRYER	46
WARNING EVENTS LIST	14	INTRODUCTION	46
TRIP EVENTS LIST	14	SYMBOLS AND LABELS USED IN THE MANUAL AND ON THE DRYER	46
START INHIBIT LIST	14	GENERAL INFORMATION	47
TRIP HISTORY	15	FUNCTIONAL DESCRIPTION	47
MAINTENANCE FOLDER	15	USE OF THE MACHINE IN SAFE CONDITIONS	47
GENERAL SETTINGS FOLDER	15	START UP	47
INTEGRAL SEQUENCING FOLDER	17	CONTROL PANEL	48
STATUS FOLDER	18	BEFORE START UP	50
FACTORY SETTINGS FOLDER	19	START UP	50
VARIABLE SPEED COMPRESSOR	19	NOTICES AND DISCLAIMERS	51
		WARRANTY	51

ABOUT THIS MANUAL

The purpose of this manual is to provide site planning, installation and operation guidelines for the compressor.

For supporting documentation refer to Table 1.

Table 1 : Product Manuals

Publication	Product	Part/Document Number by Region		
		Americas	EMEIA *	Asia Pacific
Product Safety Information Manual	R4-160 kW	80446313	80446156	80446321
Product Information Manual	R4-11 kW	80448483	80448491	80448509
Product Maintenance Manual	R4-11 kW	80448517	80448525	80448533
Product Parts Information Manual	R4-11 kW	80448541		

* Europe, Middle East, India and Africa

Product specification sheets and reference drawings are also available.

SAFETY

- Locate, read, understand and follow all Danger, Warning, Caution, and Operating Instructions on the product and in all Manuals. Failure to comply with safety precautions described in the manuals supplied with the product, this manual or any of the labels and tags attached to the product may result in death, serious injury or property damage.
- Check that all labels, tags and data (name) plates are in place and legible.
- It is your responsibility to make this information available to others.
- If you have any questions about safety or procedures not included in this manual, ask your supervisor or contact any **Ingersoll Rand** office or qualified **Ingersoll Rand** distributor.

TRANSPORTATION/ RECEIPT/ HANDLING

■ TRANSPORTATION

Ensure machine is secured against movement during transportation.

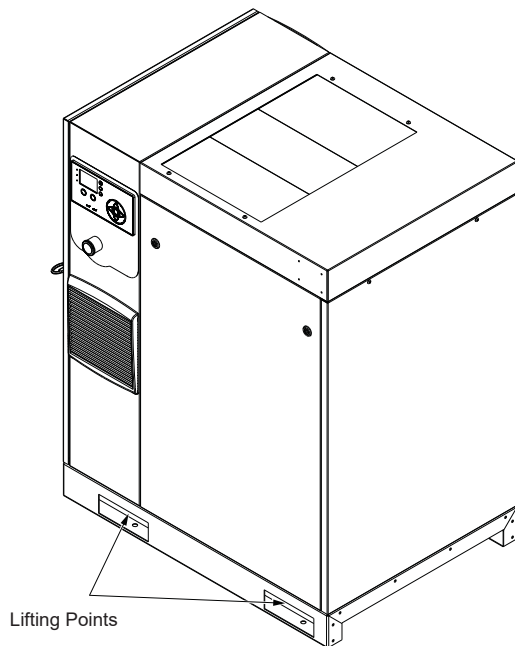

Figure 1: Lifting Points for Standard (Non-TAS) Unit.

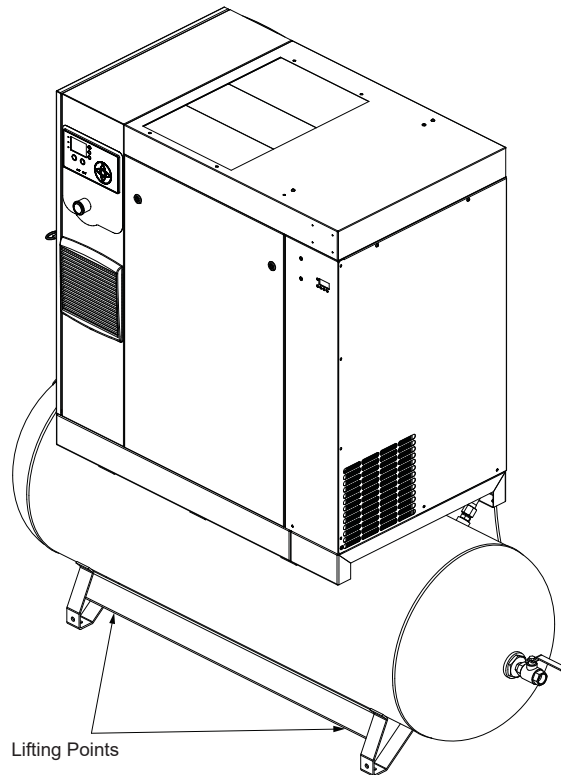

Figure 2 : Lifting Points for TAS Unit.

■ RECEIPT

Before signing the delivery receipt, inspect for damage and missing parts. If damage or missing parts are apparent, make the appropriate notation on the delivery receipt, then sign the receipt. Immediately contact the carrier for an inspection.

All material shall be held in the receiving location for the carrier's inspection.

Delivery receipts that have been signed without a notation of damage or missing parts are considered to be delivered "clear." Subsequent claims are then considered to be concealed damage claims. Settle damage claims directly with the transportation company.

If you discover damage after receiving the compressor (concealed damage), the carrier shall be notified within 15 days of receipt and an inspection shall be requested by telephone with confirmation in writing. On concealed damage claims, the burden of establishing that the compressor was damaged in transit reverts back to the claimant.

Read the compressor nameplate to verify it is the model ordered, and read the motor nameplate to verify it is compatible with your electrical conditions.

Make sure electrical enclosures and components are appropriate for the installation environment.

■ UNPACKING AND HANDLING

The compressor will normally be delivered with a polyethylene or other cover. If a knife has to be used to remove this cover, ensure that the exterior paintwork of the compressor is not damaged.

Incorporated within the base of the compressor are slots to enable a fork lift truck to move the compressor. Ensure truck forks are fully engaged on both sides. Alternatively a special lifting frame can be used to enable a crane or hoist to move the compressor. Use only marked lifting points.

■ LONG TERM STORAGE

If the product is not immediately commissioned upon receipt, the motor and airend should be moved 1/2 turn every three months to prevent damage to the bearings. If the product will not be commissioned within six months of receipt, it should be prepared for long term storage. Contact **Ingersoll Rand** for more details.

INSTALLATION

■ LOCATION IN PLANT

Figure 3 : Typical Air System

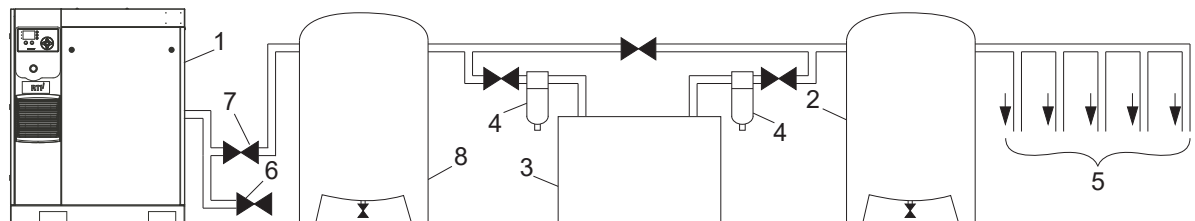

KEY

1. Compressor
2. Air Receiver Dry Tank
3. Air Dryer
4. Compressed Air Filters
5. System Demand Points
6. Vent/Drain Trap
7. Isolation Valve
8. Air Receiver Wet Tank

Standard Base-Mounted Package: Includes item [1] from Figure 3

Dryer Base-Mounted Package: Includes items [1], [3], [4], and [6] from Figure 3. (item [8] not needed for package with integrated dryer)

Standard Receiver-Mounted Package: Includes items [1], [6], [7], and [8] from Figure 3.

TAS (Total Air System) Package: Includes items [1], [2], [3], [4], [6], [7] from Figure 3. (item [8] not needed for package with integrated dryer)

The compressor can be installed on any level floor capable of supporting it. A dry, well ventilated area where the atmosphere is as clean as possible is recommended.

The area selected for the location of the compressor should be free of dust, chemicals, metal filings, paint fumes and overspray. Heat and water with chemicals present in the air can cause corrosion.

Hard surfaces may reflect noise with an apparent increase in the decibel level. When sound transmission is important, a sheet of rubber or cork can be installed beneath the compressor to reduce noise. Flexible piping may be required.

See the general arrangement drawing for minimum space requirements for normal operation and maintenance.

Minimum space in front of the control panel door as required by national or local codes shall be maintained.

Ambient temperatures higher than 40°C (104°F) shall be avoided, as well as areas of high humidity.

NOTICE

A minimum of 1 m (3.3 ft) clearance all around the compressor is recommended. If headroom is restricted, then the exhaust should be ducted or deflected away from the compressor.

Screw type compressors should not be installed in air systems with reciprocating compressors without means of isolation such as a common receiver tank. It is recommended that both types of compressor be piped to a common receiver tank using individual air lines.

■ DISCHARGE AND CONDENSATE PIPING

It is essential when installing a new compressor (1) to review the total air system. This is to ensure a safe and effective total system.

A flexible element should be installed between compressor and the discharge piping to attenuate vibration transmission.

One item which should be considered is liquid carryover. Installation of air dryers (3) is always good practice since, when properly selected and installed, they can reduce any liquid carryover to zero.

An air receiver dry tank (2) is recommended to ensure that the total system volume is sufficient.

Discharge piping should be at least as large as the discharge connection of the compressor. All piping and fittings should be suitably rated for the discharge pressure. Discharge piping should not exert any unresolved moments or force on the compressor.

It is good practice to install line filters (4).

Include a vent or drain trap (6) to vent the discharge pipework downstream from the minimum pressure check valve located on the separator tank and upstream of the first system isolation valve (7).

This compressor has an internal discharge check valve. An external check valve is not required. An isolation valve (7) is required within 1 m (36 in) of the compressor discharge.

NOTICE

There should be no plastic or PVC piping attached to this compressor or used for any lines downstream with exception of condensate removal lines.

NOTICE

The discharged air contains a very small percentage of compressor coolant and care should be taken to ensure that downstream equipment is compatible.

When two rotary compressors are operated in parallel, provide an isolation valve (7) and drain trap (6) for each compressor before the common receiver. Ensure the discharge piping is arranged to prevent water from being forced into the non-operating compressor.

A wet tank (8) is recommended in cases where the air dryer is a regenerative desiccant type to prevent short cycling the compressor during the purging cycle when plant air demand is slow.

The built-in after-cooler reduces the discharge air temperature below the dew point (for most conditions). Therefore, considerable water vapor is condensed. To remove this condensation, compressor packages that include a dryer have a built-in a condensate trap. Dryer packages without receivers require the addition of 6 mm OD tubing, connected to the dryer condensate trap, which should be appropriately routed for condensate disposal. It is recommended if the customer does not have a dryer unit or receiver-mounted unit, that they install an **Ingersoll Rand** condensate separator and trap.

A dripleg assembly and isolation valve should be mounted near the compressor discharge.

NOTICE

Do not use the compressor to support the discharge pipe.

NOTICE

The drain line must slope downward to work properly. For ease of inspection of the automatic drain trap operation, the drain piping should include an open funnel.

NOTICE

For low volume systems that may not include an air receiver tank (2), compressor response time may need adjusting. Contact your local Ingersoll Rand service provider.

■ GENERAL ELECTRICAL

The compressor is an electric motor driven, contact cooled screw compressor, complete with all necessary components piped, wired and baseplate mounted. It is a totally self-contained air compressor package.

The standard compressor is designed to operate in an ambient range of 2°C to 40°C (35°F to 104°F). The standard maximum temperature of 40°C (104°F) is applicable up to an elevation of 1000 m (3280 ft) above sea level. Above this altitude, significant reductions in ambient temperature are required if a standard motor is to be used.

For Variable Speed Drive (VSD) models, the compressor is managed by the onboard electronic controller. The controller and drive system operate together to vary the speed of the compressor to deliver compressed air at the target pressure.

For Fixed Speed (FS) models, the capacity is automatically controlled via 'Load/Unload'. The compressor will operate to maintain a set discharge line pressure and is provided with an auto restart system for use in plants where air demand varies widely.

The Controller screen displays the compressor operating conditions and general status.

■ INTEGRATED DRYER

Do not connect condensate drains common to other pressurized drain lines in a closed circuit. Make sure the outflow from the condensate drains is unimpeded. Connect the condensate piping in such a way to ensure that sound levels are kept to a minimum during drainage.

Ensure that all condensate is disposed of in a responsible manner, in compliance with all applicable standards and regulations (local, state, country, federal, etc.).

The ambient air around the dryer and compressor shall not contain solid or gaseous contaminants. All compressed and condensed gases can generate acids or chemical products which may damage the compressor or components inside the dryer. Take particular care with sulfur, ammonia, chlorine and installations in marine environments. For more details refer the Operating Instructions for Integrated Dryer section in this manual.

■ ENVIRONMENTAL LIMITS

The standard compressor package is designed for the following conditions:

- Indoors only
- Area not considered to be a high dust area.
- Ambient temperature range 2 °C to 40 °C (35.6 °F to 104 °F)

Ingersoll Rand offers the following options for fixed speed compressors that extend the environmental limits:

- Outdoor modification
- Low ambient option (-10 °C to 40 °C / 14 °F to 104 °F) at sea level
- High ambient option (2 °C to 46 °C / 35.6 °F to 115 °F) at sea level
- High dust inlet air filter

GENERAL INFORMATION

The air/coolant mixture discharges from the compressor into the separation system. This system removes all but a few ppm of the coolant from the discharge air. The coolant is returned to the cooling system and the air passes to the after-cooler and out of the compressor through the moisture separator.

Air is pulled into the compressor by the cooling fan and the through the coolant cooler and after-cooler.

By cooling the discharge air, much of the water vapor naturally contained in the air is condensed and is drained from the built-in moisture trap (for dryer machines) and drain.

The coolant system consists of a sump, cooler, thermostatic valve and a filter. When the compressor is operating, coolant is forced by air pressure from the separator tank to the thermostatic element. The position of the element (a direct result of coolant temperature) will determine whether the coolant circulates through the cooler, bypasses the cooler, or mixes the two paths together to maintain an optimum compressor discharge temperature. This temperature is controlled to preclude the possibility of water vapor condensing. By injecting coolant at a sufficiently high temperature, the discharge air coolant mixture temperature will be kept above the dew point.

The compressor is provided with a temperature sensor which will shut the compressor down in case of excessive temperature. This setting is typically 109°C (228°F).

Effective coolant filtration is provided by the use of a screw on, heavy duty coolant filter.

NOTICE

Standard air compressors are factory filled with premium coolant (Ultra/Ultra EL). It is recommended to perform a coolant analysis every 2000 hours or 3 months to monitor condition and determine when to change the coolant. If an analysis is not performed, the recommended coolant change interval for Premium Coolant (Ultra) is 8000 hours or two years, whichever comes first and for Premium Coolant (Ultra EL), the change interval is 16000 hours or three years, whichever comes first.

For compressors supplied with Food-Grade Lubricant (Ultra FG), it is recommended to perform a coolant analysis every 1000 hours to monitor condition and determine when to change the coolant. If an analysis is not performed, the recommended coolant change interval is 6000 hours.



CAUTION

Fixed speed compressors should not be connected to variable speed drives. Contact your local Ingersoll Rand representative before inverter duty conversion.



CAUTION

For fixed speed models, the compressor may not reach its normal operating temperature during periods of low demand. Sustained operation at low demand can result in the buildup of condensate in the coolant. If this situation occurs, the lubricating characteristics of the coolant can be impaired, which may lead to damage of the compressor.

The compressor should be allowed ample loading time.

Controller logic causes the compressor to continue running for 2 minutes in unloaded state to prevent this condition.

In the default mode, the dryer is non-cycling. The stop button must be pressed to shut off the dryer.

NOTICE

If ISO Class 4 dew point standards are critical to your application, run the compressor in unload mode (fixed speed) or idle mode (variable speed) for one minute at startup to allow the dryer to reach the required dew point before the compressor begins providing compressed air.

OPERATING INSTRUCTIONS (General)

■ BASIC OPERATION

NOTICE

The language and units of measure displayed on the controller will be preset before leaving the factory. If these are required to be changed, contact your local Ingersoll Rand service provider.

■ PRIOR TO STARTING

Check the coolant level by following the steps outlined in the Maintenance Manual.

Ensure that the discharge air isolation valve is open. Switch on the main electrical isolation switch. The control panel will illuminate, indicating that the line and control voltages are available.

The contrast of the controller display may be adjusted by turning the small screw which is on the right hand side of the controller when accessed through the starter cabinet door.

■ INITIAL CHECK SEQUENCE

The controller will perform an initial check sequence if the compressor receives initial power to the controller or has experienced a trip reset. While the initial check sequence occurs, the controller will display a "Checking Machine" message.

During the initial check sequence, the controller will check the control system for proper operation. During this time, if any items are found inoperative, a trip will occur and the compressor will not start.

After completion of the initial check sequence, the controller will then display "READY TO START". This process should be completed within 10 seconds.

■ START SEQUENCE

For Variable Speed Drive (VSD) machines, the compressor will initially start by the operator pressing the local start button or receiving a remote start command. The compressor will start loaded and will ramp up the motor speed to its minimum speed. Once the minimum speed has been achieved, the compressor will begin to control pressure by using its speed regulation. When the system pressure reaches the target pressure, the compressor will start to slow. If the system pressure rises to the immediate stop pressure setpoint, the compressor will stop. If the system pressure rises to the auto stop setpoint and the compressor is at minimum speed, the compressor will stop. When the machine stops, it will go through a blowdown sequence to release pressure.

For Fixed Speed (FS) machines, the compressor will initially start when the operator presses the start button or when the compressor receives a remote start signal. The compressor will be automatically loaded/unloaded when discharge pressure rises above/below the configurable setpoint. When the machine stops, it will go through a blowdown sequence to release pressure.

NOTICE

During the first startup of the compressor, check for the proper direction of rotation of the main motor, package fan motor, and dryer condenser fan. If the fan is not rotating in the direction indicated by the rotation arrow decal, reverse two of the wires at the main power supply or at the contactor in the package starter box. Perform the proper stop sequence and lockout/tagout the main electrical supply before making changes to the wiring.

■ STOP SEQUENCE

The compressor can be stopped by a local or remote stop, a shutdown due to a trip, or an emergency stop. All of the above conditions will cause the compressor to stop immediately, except the local or remote stop. A local or remote stop will open the blowdown valve and the compressor will run for 10 seconds before stopping. The machine must run unloaded for 10 seconds prior to restarting.

NOTICE

If the compressor has to be stopped in an emergency depress the emergency stop button located underneath the instrument panel.

■ EMERGENCY STOPPING

If the compressor has to be stopped in an emergency, press the emergency stop button located underneath the instrument panel.

This will override the normal unload/stop button and will immediately stop the compressor.

NOTICE

For Variable Speed Drive (VSD) machines, it is a normal situation that drive cooling fan continues to run even when the drive is stopped. And the fan can run even under an E-stop.

■ RESTARTING AFTER EMERGENCY STOPPING

If the compressor has been switched off because of a compressor malfunction, identify and correct the fault before attempting to restart.

If the compressor has been switched off for reasons of safety, ensure that the compressor can be operated safely before restarting.

Refer to the PRIOR TO STARTING and START SEQUENCE instructions earlier in the section before restarting the compressor.

OPERATING INSTRUCTIONS (XE-70M CONTROLLER)

■ USER INTERFACE

The standard user interface configuration of the controller consists of the membrane and the LCD display. The membrane consists of five command keys (Start, Stop, Load, Unload, and Reset), four navigation keys (Up, Right, Left and Down), and an Edit mode selection key (Enter). These keys, in conjunction with the graphics display and the LED icons, make up the user interface to the compressor.

Figure 4: Xe-70M

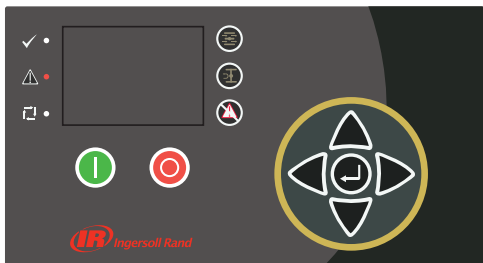

■ LED STATUS ICONS

Three LED icons are used to indicate the current status of the control system from a distance and are located on the upper left side of the user interface.

Table 2: Xe-70M LED Status Icons

Icon	Name	Function
	OK	Illuminates when no Warnings or Trips are sensed. Can be in a Ready or Not Ready state. This icon will flash when the machine is Running Unloaded.
	Alert	Illuminates when a Warning (flashes) or Trip (constant ON) is sensed. Can be in a Ready (Warning) or Tripped state.
	Auto	Illuminates when the compressor stops in auto restart.

■ COMMAND KEYS

These keys command the controller to perform actions as specified in the following table. When any of these keys are pressed the action below will be initiated and logged in the event log.

Table 3: Xe-70M Command Keys

Icon	Name	Function
	Load	Puts the compressor into the selected mode of operation. Unit will load if the pressure conditions are right.
	Unload	Puts the compressor into an unloaded state. Unit will run unloaded indefinitely.
	Reset	Clears Warnings and Trips once the fault condition is corrected.
	Start	Starts the compressor.
	Stop	Stops the compressor. This button should be pressed instead of the Emergency Stop for normal stopping operation.

Icon	Name	Function
	Enter	Toggles the display between the Navigation mode and the Edit mode.

NOTICE

The Load and Unload keys are not used on the variable speed compressors.

■ NAVIGATION KEYS

There are four navigation keys (UP, RIGHT, DOWN and LEFT). While the ENTER key is not considered a navigation key, it is used in conjunction with the navigation keys to make or confirm a selection.

Figure 5 : Navigation Keys



The navigation keys roll over. Pressing one of the navigation keys will lead the user down a navigation path. Each time the key is pressed, another step in the path is taken. Once the end of a navigation path is reached, pressing the key one more time will bring the user back to the beginning of the path. Pressing the opposite key will move the user through the navigation path in the opposite direction. Once the beginning is reached, pressing the opposite key will take the user to the end of the path.

■ DISPLAY LAYOUT

Figure 6 : Display Layout

	A
Home	B
	C
67hrs PSI 109.0°F	D
Ready to Start	

Table 4 : Display Layout

Key	Name	Description
A	Folder Bar	Uses tabs to graphically identify each folder.
B	Title Bar	Identifies current folder and page (underlined).
C	Page Content	Content of the current page.
D	Dashboard	Displays system status.

■ FOLDER NAVIGATION AND ICONS

To move among the tabbed folders shown on the LCD display, press the RIGHT and LEFT keys. The navigation rolls over from the last to the first folder and vice-versa.

Table 5 : Folder Bar Icons

Folder Name	Icon	Description
Home		System performance and status main information. The first page of this folder is the default page when the controller first powers up.
Operator Settings		System options and configuration settings.
Events		System events log.
Trip History		Details on the most recent trips.
Maintenance		Status and notification setup for compressor maintenance items.
General Settings		General settings such as Language, Time, and Units of Measure.
Integral Sequencing		Integral Sequencing communication status and configuration.
Status		Measurements or status from/of all analog and digital I/O.
Factory Settings		Compressor tuning parameters. Also displays hardware and software versions.

■ PAGE NAVIGATION

Once the desired folder is selected, press the DOWN key to move to the page selection area and then use the RIGHT and LEFT keys to select the desired page. Use the UP key to get back to the folder tabs.

Table 6 : Title Bar Page Icons

Icon	Description
	Start of the page selection area.
	Indicates that there are more pages available by navigating right.
	Indicates that there are more pages available by navigating left.

■ ACCESSING PARAMETERS

After the desired page is selected, the page's parameters can be selected by using the DOWN key. The cursor will move to the next parameter each time the DOWN key is pressed. Use the UP key to go back to the previous one.

The cursor rolls over, so once the last parameter is selected, pressing the DOWN key will navigate the cursor to the Folder Bar. If the first parameter is selected, pressing the UP key will move the cursor to the page selection area.

Once selected, access parameters by pressing the ENTER key. Make changes using the NAVIGATION keys and then enter the setting by pressing the ENTER key again. After a parameter is accessed, pressing the ENTER key will enter the current setting into the control program and navigate the cursor back to the selected parameter on the page.

When the cursor is on a parameter that has an enabled/disabled box, pressing the ENTER key will cause the setting to toggle.

This icon appears on numeric entry windows (see Figure 69). Placing the cursor on it and then pressing the ENTER key will cancel the entry and any changes that were made.

Figure 7 : Numeric Entry Window



NOTICE

Not all pages have adjustable parameters. Some just have read-only information.

■ DASHBOARD ICONS

The dashboard is intended to be a quick at-a-glance view of system status. The following table lists standard dashboard icons and their definition. Note that the color of these icons changes based on the state set by the application while running.

Table 7 : Dashboard Icons

Name	Icon	Description
Remote Control		Remote control is enabled. This can be Remote Start/Stop, COM Control, Integral Sequencing or Web Control.
Service Required		A service reminder is nearing or has expired (i.e.: an air or oil filter needs to be changed).
Unloaded or Loaded	 	Compressor is in the unloaded state. Compressor is in the loaded state.

■ DASHBOARD STATUS MESSAGES

The dashboard also displays the current operating state of the compressor. The following states can be encountered during machine operation:

- **Ready to Start** – The compressor currently has no trip or start inhibit conditions present. The machine can be started by pressing the start button at any time.
- **Starting** – A start command has been given to the compressor and the start sequence is being performed. The time period for this state can vary depending on the starter type of the machine.
- **Load Delay** – The compressor is waiting for a small period of time after starting before allowing the machine to load. This ensures the machine is at operating conditions before loading.
- **Running Loaded** – The compressor is operating and producing air. The inlet valve is open and the blow-off valve is closed.
- **Running Unloaded** – The compressor is operating, but not producing air. The inlet valve is closed and the blow-off valve is open.
- **Reload Delay** – This is a brief period of time after the compressor has unloaded before it is allowed to load again. This gives the inlet and bypass valves time to reach their proper positions.
- **Auto-Restart** – The compressor has stopped due to pressure rising above the offline or auto-stop setpoints and auto-restart being enabled. The compressor will automatically restart when pressure falls to the online or target pressure setpoint.
- **Stopping** – The compressor has received a stop command and the stop sequence is being performed.
- **Blowdown** – The compressor must wait for a brief period of time after stopping its motor before it is allowed to start again. The compressor will restart at the end of the blowdown period if a start command is received during blowdown.
- **Not Ready** – The compressor has detected a condition that will not allow the compressor to start. The condition must be cleared before a start is allowed, but does not need to be acknowledged.
- **Tripped** – The compressor has detected an abnormal operational condition that has stopped the machine. A trip must be acknowledged by hitting the reset button before the compressor can start.
- **Processor Init** – The controller is being initialized.

FIXED SPEED COMPRESSOR

HOME FOLDER

Page 1: System Overview

Figure 8 : Home Folder

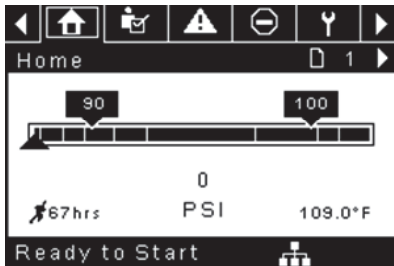

This is the factory default display after powering up the system.

- **Online Pressure Setpoint** - indicated in the black box and arrow, which is always left of center on the gauge. The compressor will load when package discharge pressure falls below this value.
- **Offline Pressure Setpoint** - indicated in the black box and arrow, which is always right of center on the gauge. The compressor will unload when package discharge pressure rises above this value.
- **Package Discharge Pressure** - indicated by the large numbers centered below the gauge and by the black arrow below the gauge. This is the air pressure that the compressor is supplying to the plant.
- **Pressure Unit of Measure** - indicated below the Package Discharge Pressure. This is selectable from the GENERAL SETTINGS folder.
- **Airend Discharge Temperature** - indicated by the numbers in the lower right of the display. This is the temperature of the air/oil mixture at the discharge of the compression module.
- **Temperature Unit of Measure** - indicated to the right of the Airend Discharge Temperature. This is selectable from the GENERAL SETTINGS folder.
- **Run Hours** - indicated by the numbers in the lower left of the display. The number of hours the compressor motor has been running.

NOTICE

The online and offline set points can be selected and modified on this page. All other information on this page is read only.

Page 2: Counters

Figure 9 : Counters

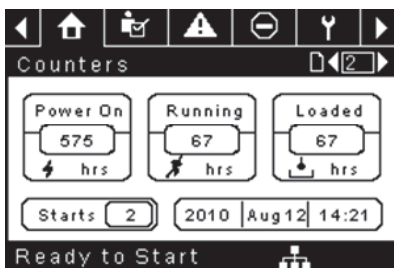

- **Hour Meters** - Indicates the hours that: the controller has been powered up, the compressor motor has been running, and the compressor has running loaded.
- **Starts** - Indicates the number of times a start is attempted on the compressor.
- **Date & Time** - Indicates the current date and time. This is adjustable and configurable in the GENERAL SETTINGS folder.

NOTICE

All information on this page is read only.

Pages 3 & 4 – Analog Inputs and Compressor Information

Figure 10 : Analog Inputs and Compressor Information

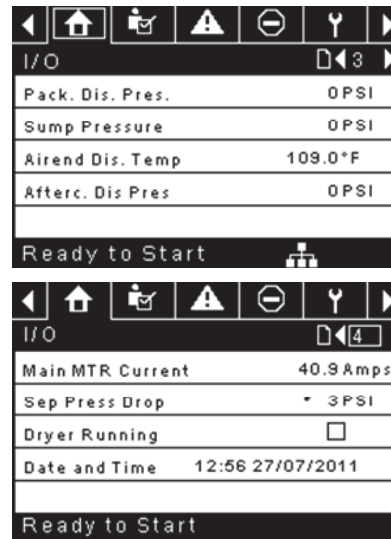

Any sensor that is not installed or is reporting a failure will show a [-] symbol.

NOTICE

All information on this page is read only.

The following analog inputs are displayed in this section.

- **Package Discharge Pressure** – The pressure the compressor is delivering to the plant.
- **Sump Pressure** – The compressor’s internal pressure at the sump tank.
- **Airend Discharge Temperature** – The temperature of the air/oil mixture at the discharge of the compression module.
- **After-cooler Discharge Temperature** – The temperature of the air after passing through the after-cooler. Note – Only shown when the Low Ambient option is purchased and installed.
- **After-cooler Discharge Pressure** – Pressure the compressor is delivering before the dryer. Note – Only shown when the TAS option is purchased and installed.
- **Separator Pressure Drop** – The pressure drop across the separator element.
- **Dryer Run Status (Integrated dryer units only)** – Checkbox that shows whether the dryer is currently running (checked) or not (blank).
- **Time and Date**
- **Main Motor Current** – Current flowing through the main motor as measured by the installed current transducers.



OPERATOR SETTINGS FOLDER

- Pages 1-2: Operator Settings

Figure 11 : Operator Settings

Setpoints	
Online Pressure	93 PSI
Offline Pressure	103 PSI
Lead/Lag Select	<input checked="" type="checkbox"/>
Lag Offset	2 PSI
Lead/Lag Cycle	0 hrs
Ready to Start	

Setpoints	
Operation Mode	On/Offline
Unload Stop Time	10 SEC
Starter Time	10 SEC
Ready to Start	

The below values are all setpoints

Online Pressure – The compressor will load when the package discharge pressure falls below this value.

Range (in PSI): 65 to Offline Pressure - 10

Offline Pressure – The compressor will unload when package discharge pressure rises above this value.

Range (in PSI): 75 to Rated Pressure + 10. Note that the range will be reduced by 7 psi when operating a TAS machine.

Lead/Lag – When this box is checked the compressor is operating as a lead machine. Unchecking the box causes the machine to run as a lag machine.

Lag Offset – If the machine is running as a lag compressor, the lag offset will be subtracted from the online and offline setpoints.

Range (in PSI): 0 – 45, depending on the online and offline setpoints. The Lag Offset will never allow you to exceed the minimum or maximum values of the online and offline setpoints.

Mode of Operation – Selection for R4-11 is Online/Offline only - determines how the compressor will try to maintain a specific pressure.

- **Online/Offline** – The compressor will load the machine by energizing a solenoid that opens the inlet valve and closes the blowdown valve when package discharge pressure falls below the online pressure setpoint. The compressor will unload the machine by de-energizing the solenoid when pressure rises above the offline pressure setpoint.

Unloaded Stop Time – Time period that the machine must run unloaded before the motor is allowed to stop after a stop command is received.

Range (in seconds): 10 - 30

Starter Time – Time period that the compressor needs in order to come up to operating speed after a start command before being able to produce air.

Range (in seconds): 5 - 30

The parameters on these pages are adjustable any time.

- Pages 3-6: Operator Options

Figure 12 : Operator Options

Options	
En Auto-Restart	<input type="checkbox"/>
AutoRestart Time	120 SEC
AutoRestart Dly	0 SEC
COM Control	<input type="checkbox"/>
Ready to Start	

Options	
Rem Start/Stop	<input type="checkbox"/>
Enable PORO	<input type="checkbox"/>
PORO Time	10 SEC
Low Ambient Temp	35°F
Ready to Start	

Options	
Sched Start Day	Sunday
Sched Start Hour	0
Sched Start Min	0
Ready to Start	

Options	
Sched Stop Day	Sunday
Sched Stop Hour	0
Sched Stop Min	0
Ready to Start	

The below values are all setpoints

Enable Auto-Restart – Enabling this will allow the compressor to stop if it has been running unloaded for a period of time, and the motor has exceeded its minimum running time (10 minute in most cases).

Auto-Restart Time – The time period the compressor must run unloaded before stopping in auto-restart. This time period begins the moment that package discharge pressure rises above the offline setpoint. Both this time period and the minimum motor run timer (10 minutes) must be satisfied before the compressor will stop in auto restart.

Range (in seconds) 2 - 60

Auto-Restart Delay – The time period after the package discharge pressure has fallen below the online setpoint before the compressor can automatically restart.

Range (in seconds): 0 - 60

Compressor Control – Enabling this setpoint allows the compressor to be controlled by a serial or Ethernet device, such as an X8I. This is equivalent to the "Sequencer" option on older Intellisys controllers.

Remote Start/Stop – Enabling this setpoint allows the compressor to be started and stopped using the digital inputs on the controller.

Enable PORO – Enabling this setpoint will allow the compressor to automatically restart after a power outage has been restored if the compressor was running loaded at the time of the outage. PORO is an option which must be purchased and installed before this feature can be turned ON.

PORO Time – Time after the controller power has been restored and controller has finished booting before the compressor will perform a PORO start. During this time the PORO Horn will sound.
Range (in seconds): 10 - 600

Low Ambient Temp – Airend discharge temperature below which the low ambient option will come into effect. The low ambient option affects the machine's operation by having the controller delay loading the machine until the airend discharge temperature rises above the setpoint value.
Range: -1.11 to 15.6°C (30 to 60°F)

Scheduled Start Day – Day (or days) of the week for which a scheduled start will be performed. The compressor will start when its onboard clock matches the day, hour, and minute of the scheduled start setpoints. Scheduled Start/Stop is an option which must be purchased and installed before this feature can be turned ON.

Scheduled Start Hour – Hour of the day for which a scheduled start will be performed. Scheduled Start/Stop is an option which must be purchased and installed before this feature can be turned ON.

Scheduled Start Minute – Minute of the hour for which a scheduled start will be performed. Scheduled Start/Stop is an option which must be purchased and installed before this feature can be turned ON.

Scheduled Stop Day – Day (or days) of the week for which a scheduled stop will be performed. The compressor will stop when its onboard clock matches the day, hour, and minute of the scheduled stop setpoints. Scheduled Start/Stop is an option which must be purchased and installed before this feature can be turned ON.

Scheduled Stop Hour – Hour of the day for which a scheduled stop will be performed. Scheduled Start/Stop is an option which must be purchased and installed before this feature can be turned ON.

Scheduled Stop Minute – Minute of the hour for which a scheduled stop will be performed. Scheduled Start/Stop is an option which must be purchased and installed before this feature can be turned ON.

Note that in order to disable Scheduled Start/Stop, the Scheduled Start and Stop days, hours, and minutes must match exactly.

* The low ambient temperature is only adjustable if the low ambient factory set point is ON.

** A value of 0 will disable the lead/lag cycle time feature.

• Page 7 Calibrate Sensors

Figure 13 : Calibrate Sensors

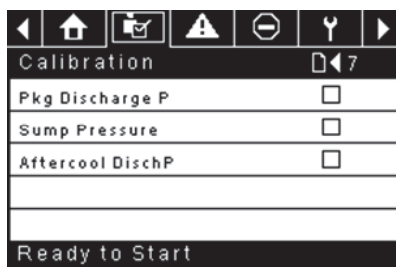

Sensor calibration can only take place when the machine is stopped and there is no pressure on the sensor. Calibration only needs to take place after a sensor is replaced, the controller is replaced, the controller software is upgraded, or the operator suspects the sensor reading is in error. Calibrate a sensor by selecting the checkbox beside the sensor name. Note that the checkbox may appear too quickly to be visible. Calibration can be confirmed by verifying that the sensor value now reads zero.

Each of the sensors listed below can be calibrated.

- Package Discharge Pressure (4APT)

Note that if a sensor is currently reading a value that is +/- 10% of its range from zero, the sensor will not be able to be calibrated and an warning will be logged in the event log. Make sure the sensor is being exposed to atmosphere before attempting calibration.

■ EVENTS FOLDER

- Pages 1 to a Max of 50

Figure 14 : Events folder

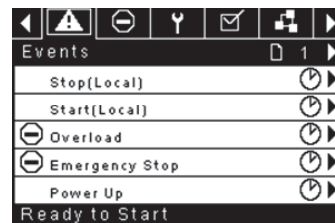

The pages in the Events folder document up to the last 250 events that the controller has experienced, with the time and date of the occurrence. The events are recorded in sequence, with number one being the newest and 250 being the oldest. When a new event occurs, it becomes number one and all others are shifted up in number.

The page numbers in the Title Bar are used to scroll through the events, with each page displaying up to five. Page one displays events one through five, page two displays six through ten, and so on.

The time and date of the event can be viewed by navigating to an event and pressing the right arrow navigation key. The time and date window can then be exited by pressing the enter key.

Figure 15 : Events folder



The following items will generate an event.

- Power ON
- Power OFF
- Press the Start Key
- Press the Stop Key
- Press the Load Key
- Press the Unload Key
- Starting the compressor remotely
- Stopping the compressor remotely
- Loading the compressor remotely
- Unloading the compressor remotely
- Warning
- Trip
- Start Inhibit

Active Warnings will show a flashing caution icon  while acknowledged Warnings will a solid icon.

Active Trips will show a flashing trip icon  while acknowledged Trips will have a solid icon.

Active Start Inhibits will be listed in the Event log, but not have an icon present. The display will indicate the compressor is not ready to start if a start inhibit is active.

■ WARNING EVENTS LIST

- **High Airend Discharge Temperature**

Xe-70M On-Screen Text: High A/E Disch T

Will occur if the unit is running and 2ATT is greater than 105 °C (221 °F) (97% of 109°C [228°F]). This condition must exist for 3 seconds before the warning is issued.

- **Service**

Service warnings occur when the unit has operated a certain number of hours, based on the total hours. Service warnings can have multiple levels, depending on the service level selection. A service level selection of 0 disables service warnings.

- **Service Level 1**

Xe-70M On-Screen Text: SVC Required

If service level 1 has been selected for the unit, a "SERVICE REQUIRED" warning will be issued on hour intervals equal to the service time period set point. This warning can be reset the same as any other warning.

- **Service Level 2**

Xe-70M On-Screen Text: 100 hours to SVC, SVC Required, Service Alarm

If service level 2 has been selected for the unit, the service complete factory set point will be used to clear a level 2 service warning and reset the service time or date. The service complete can be reset before a service warning occurs.

The initial "SERVICE REQUIRED" warning will occur at total hour intervals equal to the service time period set point. However, 100 hours before this a "100 HOURS TO SERVICE" warning will occur. This warning can be reset the same as any other warning. One hundred hours later the "SERVICE REQUIRED" warning will occur. This warning can be reset the same as any other warning, however this warning will return in 24 hours if the service complete factory set point has not been set. If the service complete has not been set, 100 hours later, the "ALARM – SERVICE REQUIRED" warning will be issued. This warning can only be cleared by the service complete factory set point. Once the service complete factory set point is set, indicating the service is completed, the time for the next "SERVICE REQUIRED" warning will be calculated by adding the service time period to the total hours value, with the "100 HOURS TO SERVICE" warning occurring 100 hours before and the "ALARM – SERVICE REQUIRED" warning occurring 100 hours after that time.

- **High Discharge Pressure**

Xe-70M On-Screen Text: High Disch Pres

Will occur if the unit is using a remote sensor or is under the control of an external device, such as an X8I, is loaded, and the discharge pressure (4APT) is greater than the maximum offline pressure. This condition must exist for 3 seconds before the warning is issued. If this condition occurs, the compressor will automatically unload. The unit will be available to reload once the discharge pressure falls to the rated pressure value.

- **Dryer Temp Warning**

Xe-70M On-Screen Text: Dryer Temp

Compressors equipped with a TAS dryer, the dryer temp warning is triggered when the dewpoint temperature exceeds 14.5 °C (58.1 °F) for 6 minutes or longer. This warning can also be triggered if the temperature probe in the dryer fails.

- **Dryer High Pressure**

Xe-70M On-Screen Text: Dryer High Pres

On units with the integrated dryer, this will occur if the dryer high pressure switch opens while the dryer is running. This is a dryer fault. If this happens, the compressor will continue to run, but the dryer will stop. The contact must be open for at least 3 seconds before the warning will occur. However, this switch is a locking switch. The dryer high pressure switch must be reset (contact closed) before this warning can be reset. If this warning is reset while the conditions for running the dryer exist, the dryer can restart.

- **Invalid Calibration**

Xe-70M On-Screen Text: Invalid Cal

Will occur if the sensor zero value is $\pm 10\%$ of its scale. See Sensor Calibration.

■ TRIP EVENTS LIST

- **High Airend Discharge Temperature**

Xe-70M On-Screen Text: High A/E Disch T

This will occur if 2ATT is greater than 109 °C (228 °F) and the unit is running.

- **Overload**

Xe-70M On-Screen Text: Overload

This will occur if the fan or main motor overload relays open. The contact must be open for at least 3 seconds before the trip will occur.

Xe-70M On-Screen Text: Main Motor OL

This will occur if the current transformers indicate that the motor amp draw is excessive. This overload is the equivalent of a class 10A trip level.

This trip is only applicable for compressors with current transformers installed.

- **Remote Stop Failure**

Xe-70M On-Screen Text: Rem Stop Fail

Will occur if the remote start/stop option is enabled, the remote stop button remains open and either start button is pressed.

- **Remote Start Failure**

Xe-70M On-Screen Text: Rem Start Fail

Will occur if the remote start/stop option is enabled, the unit is started by the remote start button, and the button stays closed for 7 seconds after the unit starts.

- **Sensor Failure**

Xe-70M On-Screen Text: 4APT Failure, 2ATT Failure, Main Motor CT Failure

This will occur when a sensor is recognized as missing or broken. The sensors affected by this trip are CT1, CT2, CT3, 4APT and 2ATT. The sensor should be displayed along with the sensor failure message. The sensor failure message shall follow the following format: 4APT Failure.

- **Emergency Stop**

Xe-70M On-Screen Text: Emergency Stop

This will occur when the EMERGENCY STOP button is engaged.

- **Unit Too Cold To Start**

Xe-70M On-Screen Text: Unit Too Cold

This will occur if the unit does not have the low ambient option, the airend discharge temperature (2ATT) is less than 1.6 °C (35 °F), and the operator attempts to start the compressor. This fault can only occur once a day. Once this fault occurs, the operator can reset it and start the compressor. This fault will be logged in the trip history to indicate that the unit is being started in low ambient conditions.

■ START INHIBIT LIST

- **High Airend Discharge Temperature**

Xe-70M On-Screen Text: High A/E Disch T

This will occur if 2ATT is greater than 95% of 109°C (228°F), which is 103°C (217°F).

■  **TRIP HISTORY**

- Pages 1 to a Max of 3

Figure 16 : Trip History



The pages in the Trips History folder document up to the last 15 trips that the controller has experienced, and time stamps each. The trips are recorded in sequence, with number one being the newest and 15 being the oldest. When a new trip occurs, it becomes number one and all others are shifted up in number.

The page numbers in the Title Bar are used to scroll through the events, with each page displaying up to seven. Page one displays events one through five, page two displays six through ten, and so on.

The following items will generate an entry in the trip history.

- Trips

Active Trips will show a flashing trip icon  while acknowledged Trips will have a solid icon.

The trip history also records compressor data at the time of the trip to assist in diagnostics and troubleshooting. Navigating to the trip entry and hitting the right navigation button will bring up the trip history dialog box.

Figure 17 : Trip History



While the dialog box is active, press the left and right keys in order to scroll through the displayed data. The name of the trip will always be shown in the title bar of the dialog box. Press enter when finished viewing the data to return to the trip history screen.

■  **MAINTENANCE FOLDER**

- Page 1 – Filter Status

Figure 18 : Filter Status

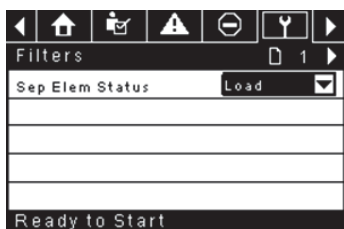

This page displays the status of the filters. The filter status will either be “OK” or “Change” depending on the compressor’s diagnostic readings. If a filter reaches the “change” status, a warning will be issued and the service indicator will light up to notify the user. Note that the compressor must be in a “Running Loaded” state to check these maintenance items. If the compressor is not in a running state – the status will display “Load,” unless a maintenance indicator has been issued when the machine was running and has not yet been reset.

The following filters are displayed:

- Separator Element

- Page 2 - Maintenance Configuration

Figure 19 : Maintenance Configuration

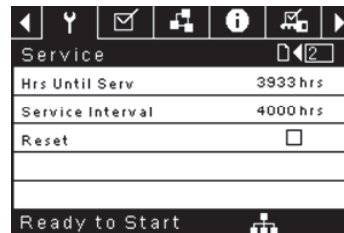

This page allows the user to set the service interval and to reset the counter after the service has been performed. The service interval may be set to any value between 1000 and 8000 hours, but must be set in accordance with the factory maintenance schedule. After maintenance has been performed, the user can reset the counter by navigating to the Reset button and pressing the enter key. Note that after changing the Service Interval a Reset must be performed to set the Hours Until Service to the proper value.

■  **GENERAL SETTINGS FOLDER**

All parameters in the general settings folder are adjustable.

- Page 1 – Language and Units Selection

Figure 20 : Language and Units Selection

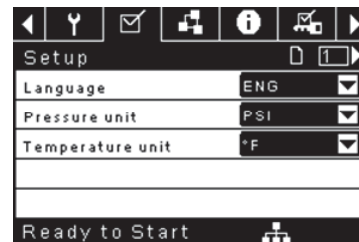

Language is selectable from the following 30 choices:

- English (default)
- Bulgarian
- Chinese, simplified
- Croatian
- Czech
- Danish
- Dutch
- Estonian
- Finnish
- French
- German
- Greek
- Hungarian
- Italian
- Indonesian
- Korean
- Latvian
- Lithuanian
- Maltese
- Norwegian
- Polish
- Portuguese
- Romanian
- Russian
- Slovak
- Slovenian
- Spanish
- Swedish
- Thai
- Turkish

The controller will display all screens in the selected language and only one language can be selected at a time.

Each language appears in its native translation.

Temperature is selectable between °F and °C.

Pressure is selectable between psi, kpa, bar, kg/cm².

• Page 2 – Time & Date Settings

Figure 21 : Time & Date Settings



All items are adjustable.

Time allows the current time to be set in a 24 hour format

Date allows the current month, day, and year to be set

Date Format is selectable between dd/mm/yyyy (default), mm/dd/yyyy, and YYYY/MM/DD

Confirm New Time and Date is used to verify that changes to selections are desired. An "x" must appear in the checkbox before any changes will take affect.

The controller will continue to display any changes, even when the selections have not been confirmed and the user exits the page, then returns. Cycling of the power returns all selections to their current settings.

NOTICE

The controller does not support Daylight Savings Time.

• Page 3 – Backlight Settings

Figure 22 : Backlight Settings



Backlight Brightness adjusts the brightness of the display.

NOTICE

The backlight will be switched ON whenever any of the controller's keys are pressed.

WARNING

The start, stop, load, unload, reset, and acknowledge keys on the controller remain functional while the backlight is switched OFF. It is recommended to press the enter key or one of the navigation keys in order to switch the backlight ON.

• Page 4 - Serial Port Address Settings

Figure 23 : Serial Port Address Settings

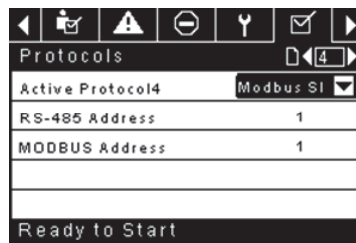

This page allows the user to set up the network addresses for the RS-485 networks the controller is capable of communicating with.

Active Protocol – Allows the serial port to be configured to Airbus (used for X-Series system controllers and integral sequencing) or MODBUS protocols.

MODBUS Address – Sets the MODBUS node ID for the controller to communicate with a MODBUS capable device, this can be any value between 1 and 254.

RS-485 Address – Sets the airbus address that allows the controller to communicate over Integral Sequencing or an X-Series system controller network.

• Pages 5 & 6 – Ethernet Settings (ECO Module Only)

Note that these pages will have no effect unless the ECO module option has been purchased.

Figure 24 : Ethernet Settings (ECO Module Only)

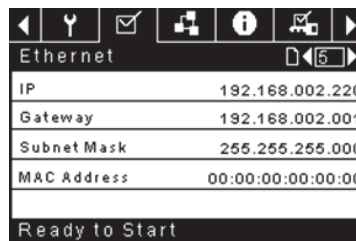

IP Address Setting – When DHCP is not enabled, this setpoint sets the IP address of the controller.

IP Address Actual – This will match the IP address setting when DHCP is not enabled. If DHCP is enabled this will display the address assigned to the controller by the DHCP server.

Default Gateway Setting – Setpoint for the default gateway.

Default Gateway Actual – Current reading/setting for the default gateway.

Subnet Mask Setting – Setpoint for the subnet mask

Subnet Mask Actual – Current reading/setting for the subnet mask

MAC Address – This is the unique hardware MAC address for the controller. This can not be changed.

Enable DHCP – Allow the controller to automatically receive an IP address from the Local Area Network (LAN)

Apply– After editing the desired setpoint navigate to the accept setting and press enter in order for the values in the setting variables to be confirmed by the controller.

Cancel – Discard any changes made to the Ethernet settings



INTEGRAL SEQUENCING FOLDER

Figure 25 : Integral Sequencing folder

Setup	
Enable ISC	<input type="checkbox"/>
Unload pressure	106 PSI
Load pressure	94 PSI
Ready to Start	

Tuning	
Start Delay Int	3 SEC
Damping	1.0
Tolerance	3 PSI
# Compressors	4
Ready to Start	

Priority	
C01 Priority	1
C02 Priority	1
C03 Priority	1
C04 Priority	1
Ready to Start	

Rotation	
Sequence	----
Rotate Now	<input type="checkbox"/>
Rotate Interval	24 hrs
Time Left	0 hrs
System Pressure	100 PSI
Ready to Start	

Integral Sequencing allows the compressor to be networked with up to three other compressors (fixed or variable speed) to maintain a stable system pressure by loading and unloading compressors as needed. Integral sequencing requires no additional hardware other than a serial two wire connection daisy chained between all compressors in the system, connected to port X04 on the controller.

For a compressor to be a member of the integral sequencing system, the COM control setpoint in the operator settings tab must be enabled and the compressor must be started via the local start button. Additionally, it is recommended that the Auto-Restart function be enabled as the integral sequencing system will never start and stop machines, only load and unload them. Integral sequencing relies on Auto-Restart to turn OFF the compressor motor when not needed.

Note that the compressor's address in the integral sequencing system is defined by the RS-485 address that is set on the general settings folder. Also note that the pressure signal used to determine when to load or unload another compressor is based on the pressure reading from the compressor assigned as the integral sequencing master. Lastly, note that the Active Protocol on the general settings tab must be set to Airbus485 for integral sequencing to operate properly.

Certain functions may interfere with compressors loading and unloading:

- Verify that the Remote Load Enable switch is in the open position. Having this closed will allow the remote load/unload switch to define the load command.

- The master controller MUST be started and running in the sequence. Otherwise, compressors will revert to their local setpoints.
- If the master controller is telling a slave controller to load and the slave's local pressure is above its maximum offline setpoint, or its immediate stop setpoint, the slave will unload locally, and remain unloaded until pressure falls below online or target setpoints.

Integral Sequencing – Enabling Integral Sequencing chooses this compressor to be the sequence Master. The master's package discharge pressure sensor will be the pressure signal used for the system. The default is disabled. Make sure all compressors are set up for integral sequencing before enabling this function. It is important that only one compressor in the system have this setpoint enabled, otherwise system behaviour could be impacted. This setpoint should also only be modified while the compressor is stopped. Note that the Integral Sequencing master does not have to be the compressor assigned RS-485 address 1.

Unload Pressure – Determines the pressure at which a compressor will be unloaded by the system. The system unload pressure should always be set lower than the local offline setpoint of compressors in the system. Note that when under system control, the compressor will ignore the local pressure setpoints except for protective functions.

Load Pressure – Determines the pressure at which a compressor will be loaded by the system. The system unload pressure should always be set lower than the local offline setpoint of compressors in the system. The system unload pressure should always be set lower than the local offline setpoint of compressors in the system. Note that when under system control, the compressor will ignore the local pressure setpoints except for protective functions.

Start Delay Interval – Determines the amount of time between loading compressors. This prevents all compressors from loading at once. This setpoint should be set to the longest starting time of any compressor in the system. In general, this will be equivalent to the star/delta transition time for a fixed speed machine, or ramp time for a VSD machine.

Damping – The pressure control "Damping" setting which is used to tune how quickly the system responds to pressure deviations. The default is 10 and should not normally be changed.

Tolerance – The pressure control "Tolerance" setting, which is used to tell the system how to respond to changes in pressure above and below the load/unload pressures. The default is 3.0 psi and should not normally be changed.

Number of Compressors – Defines how many compressors are in the system. There is a maximum of 4.

Priority – Each compressor can be assigned a priority level. Setting a priority for a compressor affects how the rotation will occur. Compressors with priority 1 will always be in the lead position(s), followed by priority 2 compressors, and so on. Compressors will only rotate positions with other compressors of the same priority level.

Sequence – Displays the current load/unload order of the system. Each compressor in the system is assigned a letter. The letter indicates whether the machine with the assigned Airbus address is a lead machine (loads first, unloads last) or one of the trim machines. Letter A is assigned to the lead machine, B to the next machine to load, C to the third machine to load, and D to the final machine to load. Machines will unload in the reverse order, such that A will be the last machine running.

The first position in the ---- sequence on Integral Sequencing tab, page 3 always refers to the compressor that is assigned Airbus Address 1. The second position to Airbus Address 2, and so on. Note that the letter sequence may change due to rotation.

Note that the sequence will only be displayed on the master controller.

Rotate Now – Selecting this setpoint will cause the sequence to shift according to the priorities, regardless of the rotation interval setpoint.

Rotation Interval – Determines the time period between automatic sequence rotations.

Time Left – Counts down the time until the sequence rotation will occur.

System Pressure – Shows the current pressure reading that the system is using for control. This will only be shown on the sequence Master controller.

**STATUS FOLDER****NOTICE**

All information on these pages is read only.

NOTICE

Some values may only be visible when the factory settings password is entered.

- Page 1 – Analog Inputs

Figure 26 : Analog Inputs

Analog Inputs	
Pkg Discharge P	100 PSI
Sump Press	7 PSI
Airend Disch T	184°F
Aftercool DischP	36 PSI
Ready to Start	

Analog Inputs:

The following analog inputs are displayed in this section.

- Package Discharge Pressure** – The pressure the compressor is delivering to the plant
- Sump Pressure** – The compressor’s internal pressure at the sump tank.
- Airend Discharge Temperature** – The temperature of the air/oil mixture at the discharge of the compression module.
- After-cooler Discharge Temperature** – The temperature of the air after passing through the After-cooler. Note that this will only be shown if the Low Ambient option has been purchased and installed.
- After-cooler Discharge Pressure (integrated dryer units only)** – Pressure the compressor is delivering before the dryer.

- Page 2 – Compressor Data

Figure 27 : Compressor data

Timers	
Running	67 hrs
Loaded	67 hrs
Power On	575 hrs
Time	14:40
Ready to Start	

Compressor Data:

- Power ON Hours** – The number of hours the controller has been powered up
- Running Hours** – The number of hours the compressor’s motor has been running
- Loaded Hours** – The number of hours the compressor has been producing air
- Real Time Clock** – Current time of day

- Pages 3 and 4 – Digital Inputs

Figure 28 : Digital inputs

Digital Inputs	
Emergency Stop	Closed
Overload	Closed
Rem Load Enable	Open
Rem Load/Unload	Open
Ready to Start	

Digital Inputs	
Remote Start	Open
Remote Stop	Closed
Dryer Temp	Open
Dryer High Press	Closed
Ready to Start	

Digital Inputs:

Each digital input will have an indication showing whether the input is in an “OPEN” or “CLOSED” state. This is the physical state of the input and may not necessarily line up with the logical condition. The normal state is shown below.

- Emergency Stop** – Normally Closed
- Main/Fan Motor Overload** – Normally Closed
- Remote Load Enable** – Normally Open
- Remote Load/Unload** – Normally Open
- Remote Start** – Normally Open
- Remote Stop** – Normally Closed
- Dryer Temperature Fault** – Normally Open
- Dryer High Pressure** – Normally Closed

- Pages 5 & 6 – Digital Outputs

Figure 29 : Digital outputs

Digital Outputs	
Contact KM1, KM2	Open
Contact KM3	Open
Fan Contact KM4	Open
L/Unload & Blowd	Open
Ready to Start	

Digital Outputs	
Modulation SV	Open
Dryer/Blower Run	Open
PORO Horn	Open
Trip Indication	Open
Ready to Start	

Digital Outputs:

Each digital output will have an indication showing whether the output is in an “OPEN” or “CLOSED” state. This is the physical state of the input and may not necessarily line up with the logical condition. The normal state is shown below.

- Starter Contact KM1, KM2** – Normally Open
- Starter Contact KM3** – Normally Open
- Fan Starter Contact KM4** – Normally Open

- **Load Solenoid 1SV** – Normally Open
 - **Dryer Run / Fan Run** – Normally Open
 - **PORO Horn** – Normally Open
 - **Trip Indication** – Normally Open
- **Page 7 – Analog Outputs**

Figure 30 : Analog outputs

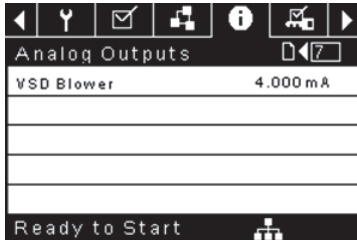

Analog Outputs:

The value for the analog outputs will be in mA.

- **VSD Blower Output** – Current speed of the VSD blower (if installed).

FACTORY SETTINGS FOLDER

This folder is for **Ingersoll Rand** factory and service personnel. A password must be entered on page one in order to adjust values in this folder. This folder is used for setting parameters that are specific to that compressor and displaying software information for the controller.

VARIABLE SPEED COMPRESSOR

HOME FOLDER

- **Page 1 – System Overview**

Figure 31 : System overview

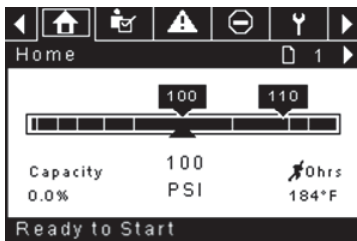

This is the factory default display after powering up the system.

Target Pressure Setpoint is indicated in the black box, which is always centered on the gauge. This is the pressure that the compressor is trying to maintain by adjusting the motor speed.

Automatic Stop Setpoint is indicated in the black box which is always right of center on the gauge. When the compressor reaches this setpoint the compressor will unload and stop once the motor reaches minimum speed and the compressor motor has been running for at least 2 minutes.

Package Discharge Pressure is indicated by the large numbers centered below the gauge and by the red arrow. This is the output pressure of the compressor.

Pressure Unit of Measure is indicated below the Package Discharge Pressure. This is selectable from the GENERAL SETTINGS folder.

Percent Capacity is indicated on the lower left side of the screen in numeric and bar graph form. This is how much air the compressor is producing as a percentage of its maximum capacity.

Airend Discharge Temperature is indicated by the numbers in the lower right of the display. This is the temperature of the air/oil mixture at the discharge of the compression module.

Temperature Unit of Measure is indicated to the right of the Airend Discharge Temperature. This is selectable from the GENERAL SETTINGS folder.

Run Hours indicate the number of hours the compressor has been running.

NOTICE

The target pressure and automatic stop set points can be selected and modified on this page. All other information on this page is read only.

- **Page 2 - Counters**

Figure 32 : Counters

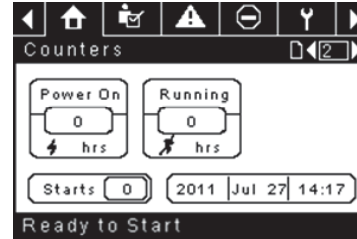

Hour Meters indicate the hours that the controller has been powered up, and the compressor has been running.

Starts indicate the number of times a start is attempted on the compressor.

Date & Time is adjustable and configurable in the GENERAL SETTINGS folder.

NOTICE

All information on this page is read only.

- **Pages 3 & 4 – Analog Inputs and Compressor Information**

Figure 33 : Analog Inputs and Compressor Information

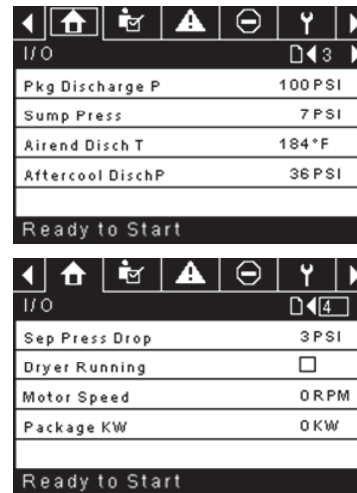

Any sensor that is not installed or is reporting a failure will show a [-] symbol.

NOTICE

All information on this page is read only.

The following analog inputs are displayed in this section.

- **Package Discharge Pressure** – The pressure the compressor is delivering to the plant
- **Airend Discharge Temperature** – The temperature of the air/oil mixture at the discharge of the compression module.
- **After-cooler Discharge Pressure (integrated dryer units only)** – Pressure the compressor is delivering before upstream of the dryer
- **Dryer Run Status (Integrated dryer units only)** – Checkbox that shows whether the dryer is currently running (checked) or not (blank)

Additionally, the following compressor status readings are included in this section:

- **Motor Speed** – The current speed of the motor in rpm
- **Package kW** – The current power being consumed by the package, including the main and blower VSDs



OPERATOR SETTINGS FOLDER

- **Pages 1 and 2 Operator Settings**

Figure 34 : Operator Settings

Setpoints	1
Target	100 PSI
Automatic Stop	110 PSI
Immediate Stop	119 PSI
Ready to Start	

Target Pressure – The compressor will vary its speed in order to maintain a package discharge pressure as close to this value as possible.
 Range (in psi): 65 - 145 (non-TAS compressors)
 : 65 - 138 (TAS Equipped Compressors)

Automatic Stop Pressure – The compressor will stop if the package discharge pressure reaches this value and the compressor is running at minimum speed.

Range (in psi): Target +1 to Target +10

Immediate Stop Pressure – The compressor will stop if the package discharge pressure reaches this value, regardless of its speed.

Range (in psi): Auto Stop Pressure to Auto Stop Pressure +10

- **Pages 2 Thru 4 Operator Options**

Figure 35 : Operator Settings

Options	2
COM Control	<input type="checkbox"/>
Rem Start/Stop	<input type="checkbox"/>
Enable PORO	<input type="checkbox"/>
PORO Time	10 SEC
Ready to Start	
Options	3
Sched Start Day	Sunday
Sched Start Hour	0
Sched Start Min	0
Ready to Start	
Options	4
Sched Stop Day	Sunday
Sched Stop Hour	0
Sched Stop Min	0
Ready to Start	

The options set points are similar to the operator set points except these set points cannot be changed while the unit is running.

Compressor Control – Enabling this setpoint allows the compressor to be controlled by a serial or Ethernet device, such as an X8I. This is equivalent to

the “Sequencer” option on older Intellisys controllers.

Remote Start/Stop – Enabling this setpoint allows the compressor to be started and stopped using the digital inputs on the controller.

Enable PORO – Enabling this setpoint will allow the compressor to automatically restart after a power outage has been restored if the compressor was running loaded at the time of the outage. PORO is an option which must be purchased and installed before this feature can be turned ON.

PORO Time – Time after the controller power has been restored and controller has finished booting before the compressor will perform a PORO start.

Scheduled Start Day – Day (or days) of the week for which a scheduled start will be performed. The compressor will start when its onboard clock matches the day, hour, and minute of the scheduled start setpoints. Scheduled Start/ Stop is an option which must be purchased and installed before this feature can be turned ON.

Scheduled Start Hour – Hour of the day for which a scheduled start will be performed. Scheduled Start/Stop is an option which must be purchased and installed before this feature can be turned ON.

Scheduled Start Minute – Minute of the hour for which a scheduled start will be performed. Scheduled Start/Stop is an option which must be purchased and installed before this feature can be turned ON.

Scheduled Stop Day – Day (or days) of the week for which a scheduled stop will be performed. The compressor will stop when its onboard clock matches the day, hour, and minute of the scheduled stop setpoints. Scheduled Start/ Stop is an option which must be purchased and installed before this feature can be turned ON.

Scheduled Stop Hour – Hour of the day for which a scheduled stop will be performed. Scheduled Start/Stop is an option which must be purchased and installed before this feature can be turned ON.

Scheduled Stop Minute – Minute of the hour for which a scheduled stop will be performed. Scheduled Start/Stop is an option which must be purchased and installed before this feature can be turned ON.

Note that in order to disable Scheduled Start/Stop, the Scheduled Start and Stop days, hours, and minutes must match exactly.

- **Page 5 Calibrate Sensors**

Figure 36 : Calibrate Sensors

Calibration	5
Pkg Discharge P	<input type="checkbox"/>
Sump Pressure	<input type="checkbox"/>
Aftercool DischP	<input type="checkbox"/>
Ready to Start	

Sensor calibration can only take place when the machine is stopped and there is no pressure on the sensor. Calibration only needs to take place after a sensor is replaced, the controller is replaced, the controller software is upgraded, or the operator suspects the sensor reading is in error. Calibrate a sensor by selecting the checkbox beside the sensor name. Note that the checkbox may appear too quickly to be visible. Calibration can be confirmed by verifying that the sensor value now reads zero.

Each of the sensors listed below can be calibrated.

- Package Discharge Pressure (4APT)

Note that if a sensor is currently reading a value that is ± 10% of its range from zero, the sensor will not be able to be calibrated and an warning will be logged in the event log. Make sure the sensor is being exposed to atmosphere before attempting calibration.

■ EVENTS FOLDER

- Pages 1 to a Max of 50

Figure 37 : Events folder

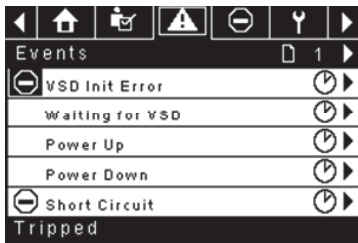

The pages in the Events folder document up to the last 200 events that the controller has experienced, with the time and date of the occurrence. The events are recorded in sequence, with number one being the newest and 200 being the oldest. When a new event occurs, it becomes number one and all others are shifted up in number.

The page numbers in the Title Bar are used to scroll through the events, with each page displaying up to seven. Page one displays events one through five, page two displays six through ten, and so on.

The time and date of the event can be viewed by navigating to an event and pressing the right arrow navigation key. The time and date window can then be exited by pressing the enter key.

Figure 38 : Events folder

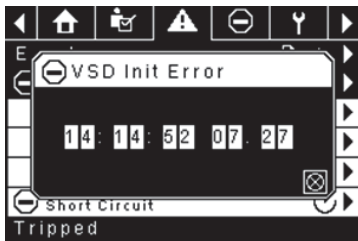

The following items will generate an event.

- Power ON
- Power OFF
- Press the Start Key
- Press the Stop Key
- Press the Load Key
- Press the Unload Key
- Starting the compressor remotely
- Stopping the compressor remotely
- Loading the compressor remotely
- Unloading the compressor remotely
- Warning
- Trip
- Start Inhibit

Active Warnings will show a flashing caution icon  while acknowledged Warnings will a solid icon.

Active Trips will show a flashing trip icon  while acknowledged Trips will have a solid icon.

Active Start Inhibits will be listed in the Event log, but not highlighted. The display will indicate the compressor is not ready to start if a start inhibit is active.

■ WARNING EVENTS LIST

• High Airend Disch Temp

Xe-70M On-Screen Text: High A/E Disch T

Will occur if the unit is running and 2ATT is greater than 105°C (221°F) (97% of 109°C [228°F]) or the unit is in idle mode (3.3.7.1) and 2ATT is greater than 84.4°C (184°F). This warning will have a 90 second delay.

• High Discharge Press

Xe-70M On-Screen Text: High Disch Press

Will occur if the unit is under the control of an external device, such as an X-series system controller, and the discharge pressure is greater than the immediate stop pressure for a time period of 3 seconds. At this point, the controller will unload the compressor until package discharge pressure falls back below the target pressure setpoint.

• Service

Service warnings occur when the unit has operated a certain number of hours, based on the total hours. Service warnings can have multiple levels, depending on the service level selection. Selecting service level 0 disables service warnings.

• Service Level 1

Xe-70M On-Screen Text: SVC Required

If service level 1 has been selected for the unit, a "SERVICE REQUIRED" warning will be issued the amount of operating hours in the Service Time Period set point. This warning can be reset the same as any other warning.

• Service Level 2

Xe-70M On-Screen Text: 100 Hrs to SVC, SVC Required, Service Alarm

If service level 2 has been selected for the unit, the service complete factory set point will be used to clear a level 2 service warning and reset the service time or date. The service complete can be reset before a service warning occurs.

The first "SERVICE REQUIRED" warning will occur at the total hours value of the service time period set point. However, 100 hours before this a "100 HOURS TO SERVICE" warning will occur. This warning can be reset the same as any other warning. One hundred hours later, at the total hours value of the service time period, the "SERVICE REQUIRED" warning will occur. This warning can be reset the same as any other warning, however this warning will return in 24 hours if the service complete factory set point has not be set. If the service complete has not been set, 100 hours later (service time period + 100) the "ALARM - SERVICE REQUIRED" warning will be issued. This warning can only be cleared by the service complete factory set point. Once the service complete factory set point is set, indicating the service is completed, the time for the next "SERVICE REQUIRED" warning will be calculated by adding the service time period to the total hours value, with the "100 HOURS TO SERVICE" warning occurring 100 hours before and the "ALARM - SERVICE REQUIRED" warning occurring 100 hours after that time.

• High VSD Ambient Temperature

Xe-70M On-Screen Text: High VSD Amb T

This warning will occur if the VSD ambient temperature gets within 5% of the shutdown value of 56.1°C (133°F). This condition must exist for 3 seconds before the warning is issued.

• Dryer Temp Warning

Xe-70M On-Screen Text: Dryer Temp

Note that the dryer temp warning is triggered when the dewpoint temperature exceeds 14.5 °C (58.1 °F) for 6 minutes or longer. This warning can also be triggered if the temperature probe in the dryer fails.

• Dryer High Pressure

Xe-70M On-Screen Text: Dryer High Pres

On units with the integrated dryer, this will occur if the dryer high pressure switch opens while the dryer is running. This is a dryer fault. If this happens, the compressor will continue to run, but the dryer will stop. The contact must be open for at least 3 seconds before the warning will occur. If this warning is reset while the conditions for running the dryer exist, the dryer can restart.

However, this switch is a locking switch. The dryer high pressure switch must be reset (contact closed) before this warning can be reset. If this warning is reset while the conditions for running the dryer exist, the dryer can restart.

- **Invalid Calibration**

Xe-70M On-Screen Text: Invalid Cal

This will occur if the sensor zero value is $\pm 10\%$ of its scale.

■ TRIP EVENTS LIST

- **High Airend Disch Temp**

Xe-70M On-Screen Text: High A/E Disch T

This will occur if 2ATT is greater than 109 °C (228 °F) during normal operation. This trip will occur at 93 °C (200 °F) if the unit is in idle mode.

- **Overload**

Xe-70M On-Screen Text: Overload

This will occur if the fan overload relay opens. The contact must be open for at least 3 seconds before the trip will occur.

- **Remote Stop Failure**

Xe-70M On-Screen Text: Rem Stop Fail

Will occur if the REMOTE START/STOP option is enabled, the remote stop button remains open and either start button is pressed.

- **Remote Start Failure**

Xe-70M On-Screen Text: Rem Start Fail

Will occur if the unit is started by the remote start button and the button stays closed for 7 seconds after the unit starts.

- **Sensor Failure**

Xe-70M On-Screen Text: 4APT Failure, 2ATT Failure, Main Motor CT Failure

This will occur when a sensor is recognized as missing or broken. The sensors affected by this trip are CT1, CT2, CT3, 4APT, and 2ATT. The sensor should be displayed along with the sensor failure message. The sensor failure message shall follow the following format: 4APT Failure.

- **Emergency Stop**

Xe-70M On-Screen Text: Emergency Stop

This will occur when the EMERGENCY STOP button is engaged.

- **VSD Fault X**

Xe-70M On-Screen Text: VSD Fault 'X'

The compressors variable speed drive is reporting a fault. Refer to the troubleshooting guide for further information.

- **Check Motor Rotation**

Xe-70M On-Screen Text: Ck Motor Rot

This will occur if the controller reads a negative speed from the VSD when starting.

- **VSD Communication Failure**

Xe-70M On-Screen Text: VSD Comm Fail

This will occur if the controller does not receive a response from the VSD when requesting information. This trip will take about 8 seconds to occur.

- **Incorrect VSD Type**

Xe-70M On-Screen Text: Wrong VSD Type

This will occur at power up if the VSD type does not match the size of compressor. The controller will determine this by comparing the compressor type with the drive ID.

- **Stop Failure**

Xe-70M On-Screen Text: Stop Failure

This will occur if the compressor should be stopped, but the motor speed has not dropped below the minimum motor speed set point. The controller will wait 4 seconds for the compressor to stop before issuing this trip. This is normally an indication the run relay (K1) did not open when de-energized. Because of this, the isolation contact should open when this fault occurs. The isolation contact can close when this fault is cleared, if the unit is not water cooled.

- **VSD Initialization Fault**

Xe-70M On-Screen Text: Drive Init Error

This will occur if the controller is unable to properly set-up the drive after boot or after a reset. The controller will attempt to write a parameter 10 times to the drive, after these 10 attempts have failed this trip will be registered.

Xe-70M On-Screen Text: VSD Comm Except

This will occur if the controller receives invalid communications from the VSD. Refer to the troubleshooting guide for further information.

■ START INHIBIT LIST

- **High Airend Discharge Temperature**

Xe-70M On-Screen Text: High A/E Disch T

This will occur if 2ATT is greater than 95% of 109 °C (228 °F).

- **VSD Initialization**

Xe-70M On-Screen Text: VSD Initializing

This will occur if the compressor VSD has not responded to the initial communications from the controller.

■ TRIP HISTORY

- **Pages 1 to A Max of 3**

Figure 39 : Trip History

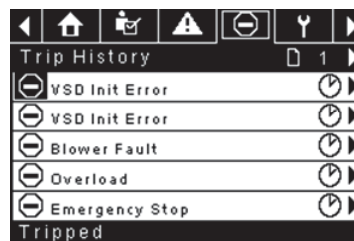

The pages in the Trips History folder document up to the last 15 trips that the controller has experienced, and time stamps each. The trips are recorded in sequence, with number one being the newest and 15 being the oldest. When a new trip occurs, it becomes number one and all others are shifted up in number.

The page numbers in the Title Bar are used to scroll through the events, with each page displaying up to seven. Page one displays events one through five, page two displays six through ten, and so on.

The following items will generate an entry in the trip history.

- Trips

Active Trips will show a flashing trip icon  while acknowledged Trips will have a solid icon.

The trip history also records compressor data at the time of the trip to assist in diagnostics and troubleshooting. Navigating to the trip entry and hitting the enter button will bring up the trip history dialog box.

Figure 40 : Trip History

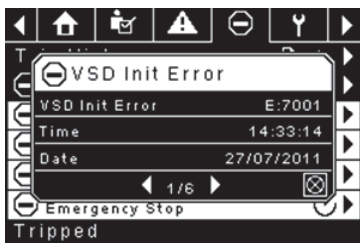

While the dialog box is active, press the left and right keys in order to scroll through the displayed data. The name of the trip will always be shown in the title bar of the dialog box. Press enter when finished viewing the data to return to the trip history screen.



MAINTENANCE FOLDER

- Page 1 – Filter Status

Figure 41 : Filter Status

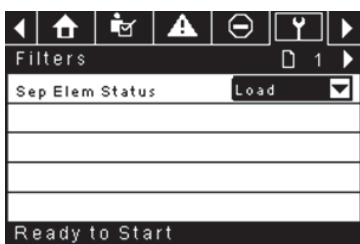

This page displays the status of the filters. The filter status will either be “OK” or “Change” depending on the compressor’s diagnostic readings. If a filter reaches the “change” status, a warning will be issued and the service indicator will light up to notify the user. Note that the compressor must be in a “Running Loaded” state to check these maintenance items. If the compressor is not in a running state – the status will display “Load,” unless a maintenance indicator has been issued when the machine was running and has not yet been reset.

The following filters are displayed:

- Separator Element

- Page 2 - Maintenance Configuration

Figure 42 : Maintenance Configuration

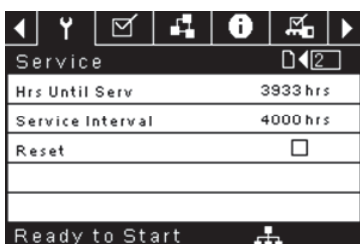

This page allows the user to set the service interval and to reset the counter after the service has been performed. The service interval may be set to any value between 1000 and 8000 hours, but must be set in accordance with the factory maintenance schedule. After maintenance has been performed, the user can reset the counter by navigating to the Reset button and pressing the enter key. Note that after changing the Service Interval a Reset must be performed to set the Hours Until Service to the proper value.



GENERAL SETTINGS FOLDER

All parameters in the general settings folder are adjustable.

- Page 1 – Language & Units Selection

Figure 43 : Language & Units Selection

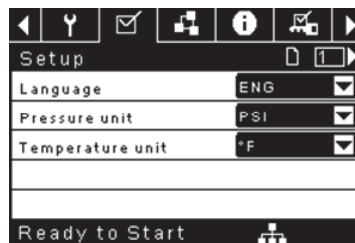

Language is selectable from the following 30 selections:

- English (default)
- Bulgarian
- Chinese, simplified
- Croatian
- Czech
- Danish
- Dutch
- Estonian
- Finnish
- French
- German
- Greek
- Hungarian
- Italian
- Indonesian
- Korean
- Latvian
- Lithuanian
- Maltese
- Norwegian
- Polish
- Portuguese
- Romanian
- Russian
- Slovak
- Slovenian
- Spanish
- Swedish
- Thai
- Turkish

The controller will display all screens in the selected language and only one language can be selected at a time.

Each language appears in its native translation.

Temperature is selectable between °F and °C.

Pressure is selectable between psi, kpa, bar, kg/cm².

- Page 2 – Time & Date Settings

Figure 44 : Time & Date Settings

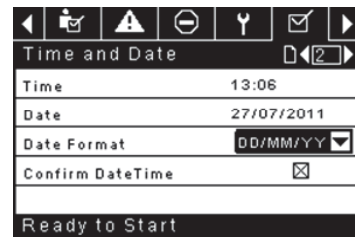

All items are adjustable.

Time allows the current time to be set in a 24 hour format

Date allows the current month, day, and year to be set

Date Format is selectable between dd/mm/yyyy (default), mm/dd/yyyy, and YYYY/MM/DD

Confirm New Time and Date is used to verify that changes to selections are desired. An “x” must appear in the checkbox before any changes will take affect.

The controller will continue to display any changes, even when the selections have not been confirmed and the user exits the page, then returns. Cycling of the power returns all selections to their current settings.

NOTICE

The controller does not support Daylight Savings Time.

• **Page 3 – Backlight Settings**

Figure 45 : Backlight Settings

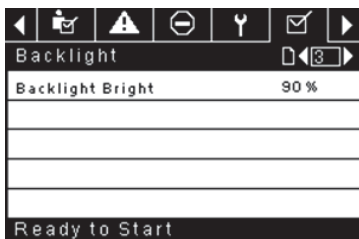

Backlight Brightness adjusts the brightness of the display.

NOTICE

The backlight will be switched ON whenever any of the controller's keys are pressed.

WARNING

The start, stop, load, unload, reset, and acknowledge keys on the controller remain functional while the backlight is switched OFF. It is recommended to press the enter key or one of the navigation keys in order to switch the backlight ON.

• **Page 4 - Serial Port Address Settings**

Figure 46 : Serial Port Address Settings

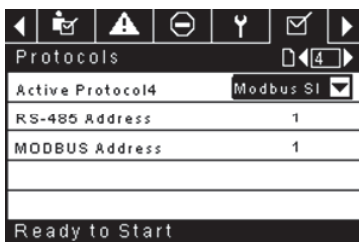

This page allows the user to set up the network addresses for the RS-485 networks the controller is capable of communicating with.

Active Protocol – Allows the serial port to be configured to Airbus (used for X-Series system controllers and integral sequencing) or MODBUS protocols

MODBUS Address – Sets the MODBUS node ID for the controller to communicate with a MODBUS capable device, this can be any value between 1 and 254.

RS-485 Address – Sets the airbus address that allows the controller to communicate over Integral Sequencing or an X-Series system controller network.

• **Pages 5 & 6 – Ethernet Settings (ECO Module Only)**

The ECO Module is the Ethernet Connectivity Option. This option allows the customer to connect to a LAN and view web pages served by the controller. The ECO module also has the ability to store up to the past seven days of operational data for troubleshooting purposes.

Note that these pages will have no effect unless the ECO module option has been purchased.

Figure 47 : Ethernet Settings (ECO Module Only)

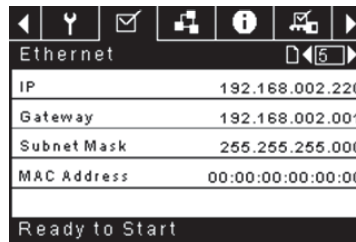

IP Address Setting – When DHCP is not enabled, this setpoint sets the IP address of the controller.

IP Address Actual – This will match the IP address setting when DHCP is not enabled. If DHCP is enabled this will display the address assigned to the controller by the DHCP server.

Default Gateway Setting – Setpoint for the default gateway.

Default Gateway Actual – Current reading/setting for the default gateway.

Subnet Mask Setting – Setpoint for the subnet mask

Subnet Mask Actual – Current reading/setting for the subnet mask

MAC Address – This is the unique hardware MAC address for the controller. This can not be changed.

Enable DHCP – Allow the controller to automatically receive an IP address from the Local Area Network (LAN)

Apply– After editing the desired setpoint navigate to the accept setting and press enter in order for the values in the setting variables to be confirmed by the controller.

Cancel – Discard any changes made to the Ethernet settings.

■ **INTEGRAL SEQUENCING FOLDER**

Figure 48 : Integral Sequencing

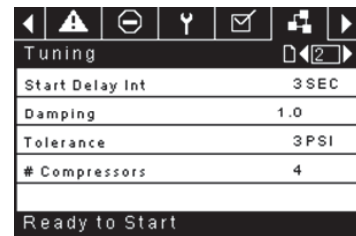
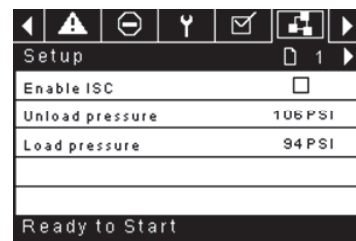

Priority	
C01 Priority	1
C02 Priority	1
C03 Priority	1
C04 Priority	1
Ready to Start	

Rotation	
Sequence	----
Rotate Now	<input type="checkbox"/>
Rotate Interval	24 hrs
Time Left	0 hrs
System Pressure	100 PSI
Ready to Start	

Integral Sequencing allows the compressor to be networked with up to three other compressors (fixed or variable speed) to maintain a stable system pressure by loading and unloading compressors as needed. Integral sequencing requires no additional hardware other than a serial two wire connection daisy chained between all compressors in the system, connected to port X04 on the controller.

For a compressor to be a member of the integral sequencing system, the COM control setpoint in the operator settings tab must be enabled and the compressor must be started via the local start button. Additionally, it is recommended that the Auto-Restart function be enabled as the integral sequencing system will never start and stop machines, only load and unload them. Integral sequencing relies on Auto-Restart to turn OFF the compressor motor when not needed.

Note that the compressor's address in the integral sequencing system is defined by the RS-485 address that is set on the general settings folder. Also note that the pressure signal used to determine when to load or unload another compressor is based on the pressure reading from the compressor assigned as the integral sequencing master. Lastly, note that the Active Protocol on the general settings tab must be set to Airbus485 for integral sequencing to operate properly.

Certain functions may interfere with compressors loading and unloading:

- Verify that the Remote Load Enable switch is in the open position. Having this closed will allow the remote load/unload switch to define the load command.
- The master controller MUST be started and running in the sequence. Otherwise, compressors will revert to their local setpoints.
- If the master controller is telling a slave controller to load and the slave's local pressure is above its maximum offline setpoint, or its immediate stop setpoint, the slave will unload locally, and remain unloaded until pressure falls below online or target setpoints.

Integral Sequencing – Enabling Integral Sequencing chooses this compressor to be the sequence Master. The master's package discharge pressure sensor will be the pressure signal used for the system. The default is disabled. Make sure all compressors are set up for integral sequencing before enabling this function. It is important that only one compressor in the system have this setpoint enabled, otherwise system behaviour could be impacted. This setpoint should also only be modified while the compressor is stopped. Note that the Integral Sequencing master does not have to be the compressor assigned RS-485 address 1.

Unload Pressure – Determines the pressure at which a compressor will be unloaded by the system. The system unload pressure should always be set lower than the local offline setpoint of compressors in the system. Note that when under system control, the compressor will ignore the local pressure setpoints except for protective functions.

Load Pressure – Determines the pressure at which a compressor will be loaded by the system. The system unload pressure should always be set lower than the local offline setpoint of compressors in the system. The system unload pressure should always be set lower than the local offline setpoint of compressors in the system. Note that when under system control, the compressor will ignore the local pressure setpoints except for protective functions.

Start Delay Interval – Determines the amount of time between loading compressors. This prevents all compressors from loading at once. This setpoint should be set to the longest starting time of any compressor in the system. In general, this will be equivalent to the star/delta transition time for a fixed speed machine, or ramp time for a VSD machine.

Damping – The pressure control "Damping" setting which is used to tune how quickly the system responds to pressure deviations. The default is 10 and should not normally be changed.

Tolerance – The pressure control "Tolerance" setting, which is used to tell the system how to respond to changes in pressure above and below the load/unload pressures. The default is 3.0 psi and should not normally be changed.

Number of Compressors – Defines how many compressors are in the system. There is a maximum of 4.

Priority – Each compressor can be assigned a priority level. Setting a priority for a compressor affects how the rotation will occur. Compressors with priority 1 will always be in the lead position(s), followed by priority 2 compressors, and so on. Compressors will only rotate positions with other compressors of the same priority level.

Sequence – Displays the current load/unload order of the system. Each compressor in the system is assigned a letter. The letter indicates whether the machine with the assigned Airbus address is a lead machine (loads first, unloads last) or one of the trim machines. Letter A is assigned to the lead machine, B to the next machine to load, C to the third machine to load, and D to the final machine to load. Machines will unload in the reverse order, such that A will be the last machine running.

The first position in the ---- sequence on Integral Sequencing tab, page 3 always refers to the compressor that is assigned Airbus Address 1. The second position to Airbus Address 2, and so on.

Note that the letter sequence may change due to rotation.

Note that the sequence will only be displayed on the master controller.

Rotate Now – Selecting this setpoint will cause the sequence to shift according to the priorities, regardless of the rotation interval setpoint.

Rotation Interval – Determines the time period between sequence rotations.

Time Left – Counts down the time until the sequence rotation will occur.

System Pressure – Shows the current pressure reading that the system is using for control. This will only be shown on the sequence Master controller.

STATUS FOLDER

NOTICE

All information on these pages is read only. Page numbers are valid for when the password is entered. When the password is not entered the pages may be arranged slightly differently.

Page 1 – Analog Inputs

Figure 49 : Analog Inputs

Analog Inputs	
Pkg Discharge P	100 PSI
Sump Press	7 PSI
Airend Disch T	184 °F
Aftercool DischP	36 PSI
Ready to Start	

Analog Inputs:

The following analog inputs are displayed in this section.

- **Package Discharge Pressure** – The pressure the compressor is delivering to the plant
- **Airend Discharge Temperature** – The temperature of the air/oil mixture at the discharge of the compression module.
- **Pages 2 Thru 4 – Compressor Data**

Figure 50 : Compressor Data

Timers	
Running	67 hrs
Loaded	67 hrs
Power On	575 hrs
Time	14:40
Ready to Start	
VSD	
Motor Speed	0 RPM
Motor Current	0 Amps
Motor Voltage	0 V
DC Link Voltage	0 V
Tripped	
VSD	
Package KW	0 KW
Heatsink Temp	32.0 °F
Contr. Card Temp	32.0 °F
Tripped	

Compressor Data:

- **Power ON Hours** – Number of hours that the controller has been powered up
- **Running Hours** – Number of hours the compressor's motor has been running
- **Motor Speed** – Current speed of the motor in RPM
- **Time** – Current time of day.

- **Motor Current** – Electrical current currently being drawn by the motor.
- **Motor Voltage** – Electrical voltage at the motor.
- **DC Link Voltage** – DC Bus Voltage on the VSD
- **Package kW** – Instantaneous power consumption of the compressor
- **Heatsink Temperature** – Temperature of the VSD at the heatsink
- **Control Card Temperature** – Temperature of the VSD at the control card
- **Pages 5 & 6 – Digital Inputs**

Figure 51 : Digital Inputs

Digital Inputs	
Emergency Stop	Closed
Fan Motor OL	Closed
Unused	Open
Unused	Open
Ready to Start	

Digital Inputs	
Remote Start	Open
Remote Stop	Closed
Dryer Temp	Open
Dryer High Press	Closed
Ready to Start	

Digital Inputs: (Password Required)

Each digital input will have an indication showing whether the input is in an "OPEN" or "CLOSED" state. This is the physical state of the input and may not necessarily line up with the logical condition. The normal state is shown below.

- **Emergency Stop** – Normally Closed
- **Main/Fan Motor Overload** – Normally Closed
- **Remote Start** - Normally Open
- **Remote Stop** – Normally Closed
- **Dryer Temperature Fault** – Normally Open
- **Dryer High Pressure** – Normally Closed

- Pages 7 & 8 – Digital Outputs

Figure 52 : Digital Outputs

Digital Outputs	
VSD Run	Open
Unused	Open
Fan Contact KM4	Open
Blowdown solenoid	Open
Tripped	

Digital Outputs	
Unused	Open
Dryer Run	Open
PORO Horn	Open
Trip Indication	Closed
Tripped	

Digital Outputs (Password Required):

Each digital output will have an indication showing whether the output is in an "OPEN" or "CLOSED" state. This is the physical state of the input and may not necessarily line up with the logical condition. The normal state is shown below.

- **VSD Run K1 Contact** – Normally Open
- **Fan Starter Contact KM4** – Normally Open
- **Blowdown Solenoid 15V** – Normally Open
- **Dryer Run / Fan Run** – Normally Open
- **PORO Horn** – Normally Open
- **Trip Indication** – Normally Open

- Page 53 – Analog Outputs

Figure 53 : Analog Outputs

Analog Outputs	
VSD Output	0.400 mA
Tripped	

Analog Outputs:

The value for the analog outputs will be in mA.

- VSD Output

■ **FACTORY SETTINGS FOLDER**

This folder is for **Ingersoll Rand** factory and service personnel. A password must be entered on page one in order to adjust values in this folder. This folder is used for setting parameters that are specific to that compressor and displaying software information for the controller.

MODBUS CONNECTION AND CONTROL

CONNECTION TO THE MODBUS NETWORK

The Xe-70M controller is designed to interface to any MODBUS RTU master capable device using Belden 9841 or equivalent RS-485 cable. In order to connect to the network, the cable must be connected to port X04 on the controller as shown in the figure below:

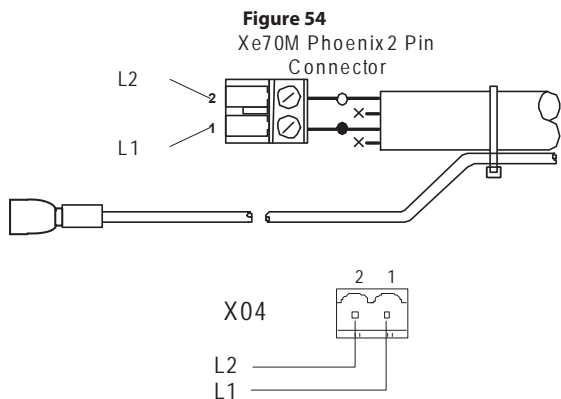

RS-485 NETWORK

RS-485 data communications and other low voltage signals can be subject to electrical interference.

This potential can result in intermittent malfunction or anomaly that is difficult to diagnose. To avoid this possibility always use earth shielded cables, securely bonded to a known good earth at one end. In addition, give careful consideration to cable routing during installation.

1. Never route an RS-485 data communications or low voltage signal cable alongside a high voltage 3-phase power supply cable. If it is necessary to cross the path of a power supply cable(s), always cross at a right angle.
2. If it is necessary to follow the route of power supply cables for a short distance (for example: from a compressor unit to a wall along a suspended cable tray) attach the RS-485 or signal cable on the outside of an earthed cable tray such that the cable tray forms an earthed electrical interference shield.
3. Where possible, never route an RS-485 or signal cable near to equipment or devices that may be a source of electrical interference (for example: 3-phase power supply transformer, high voltage switchgear unit, frequency inverter drive module, radio communications antenna).

Figure 55

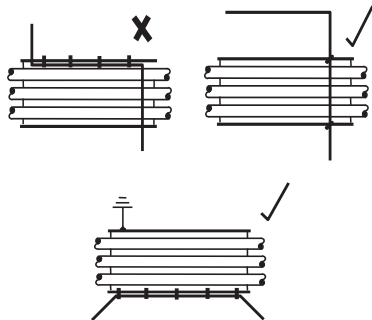

MODBUS ADDRESS SELECTION

Each compressor connected to the MODBUS network will have a unique assigned address, starting at compressor 1 increasing sequentially to the number of compressors connected to the MODBUS network.

The MODBUS address for each compressor is set on the General Settings Tab, Page 4. The controller's default MODBUS Address setting is 1,

Additionally, the active protocol must be set to MODBUS Slave.

Figure 56: Protocols

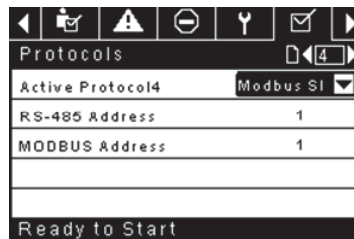

MODBUS MASTER SETTINGS

In order to communicate properly with the Xe-70M controller, the MODBUS master must be set to communicate with the following configuration:

Baud Rate – 9600

Data Bits – 8

Stop Bits – 1

Parity – None

The following polling parameters are recommended for optimal system operation:

Polling Rate: Not less than 500 ms

Timeout: 500 ms

Retries: 2

WEB ACCESS

Ingersoll Rand Xe-70M with ECO Module Option web pages are a visualization application which offers a window using a web browser on your PC. The web pages allows the user to monitor air system at a glance or take a more detailed look into system operation, equipment status and setup through an intuitive web-page based user interface. To access this application running on the controller, simply connect via a Web Browser from any PC using an Ethernet connection. The PC can be local stand alone or part of a LAN.

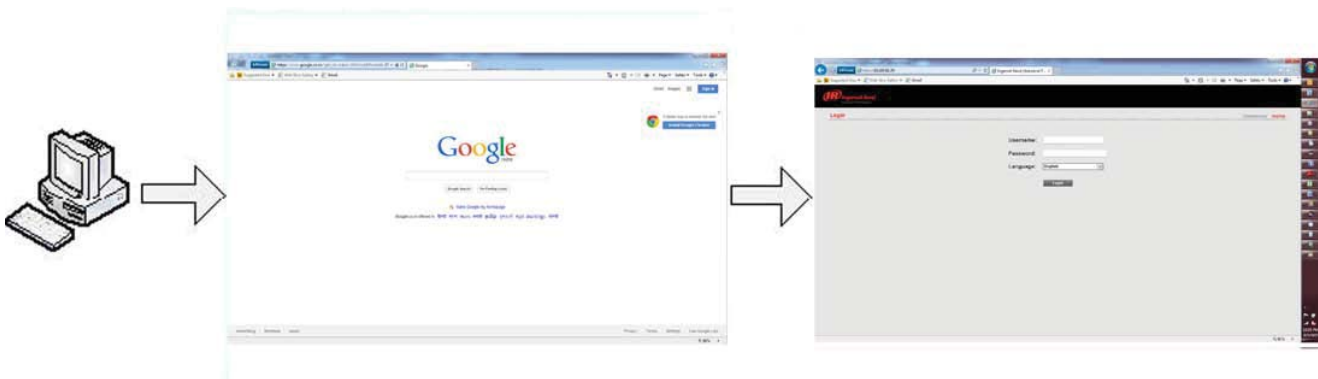

The system administrator can assign a user one of three levels of access (view only, user, and administrator) which will determine which functions will be available to that user. For example, only users with administrator access will be able to make new accounts and to view or modify the configuration overview parameters. See section Account Management.

The Xe-70M with ECO Module Option functions as a web server for the compressor. The web server offers the following through the interface:

- Display of current operating state of the compressor
- Compressor Information – model number, serial number, rated capacity and other details
- Start, Stop, Reset Alarm, Load and Unload buttons
- Adjust operating parameters
- Display of analog signals
- Display of hour meters
- Display of Event log
- Display of maintenance timers
- Edit and display of maintenance log
- Notification of alarm/trip events via email

COMMISSIONING PROCEDURES

There are certain parameters that must be configured in order for the controller to properly communicate to the LAN and to the network. Outlined below is a list of steps that must be completed before the visualization software can be fully utilized. Please be sure that you have ADMIN rights before attempting to configure the controller.

If you will only be connecting to the controller to a single PC, go to step 1. If you will be using a static IP or DHCP assigned IP address on your company's LAN please go to step 2.

1. Connect the controller to a PC – Follow the procedure outlined in section "CONNECTING TO A PC". Please go to step 3.
2. Configure the controller Ethernet settings – Obtain a static IP address from your IT department or have an assigned domain name for DHCP access. Follow the procedures in "ETHERNET CONFIGURATION".
3. Login to the web pages – Follow the procedure in section "LOGIN PROCESS".
4. Configure compressor information – Follow the procedures in section "COMPRESSOR INFORMATION". Make sure you have the compressor nameplate data available.
5. Set up user accounts – Follow the procedures in section "ACCOUNT MANAGEMENT".

WEB ACCESS

CONNECTING TO A PC

In order to configure your computer to communicate point-to-point with the Xe-70M with ECO Module Option, you must first set the IP address range of your computer to the default IP address range of the controller. To do this, please follow the instructions listed below to configure the computer IP address. These settings are accessible using Windows XP by selecting:

Using Classic View:

- Select Start
- Select Settings
- Select Network Connections

Using XP Start View:

- Select Start
- Select Control Panel
- Select Network Connections

Please note that the controller ships with a default IP address of 192.168.2.220

1. Select "Local Area Connection" from the list

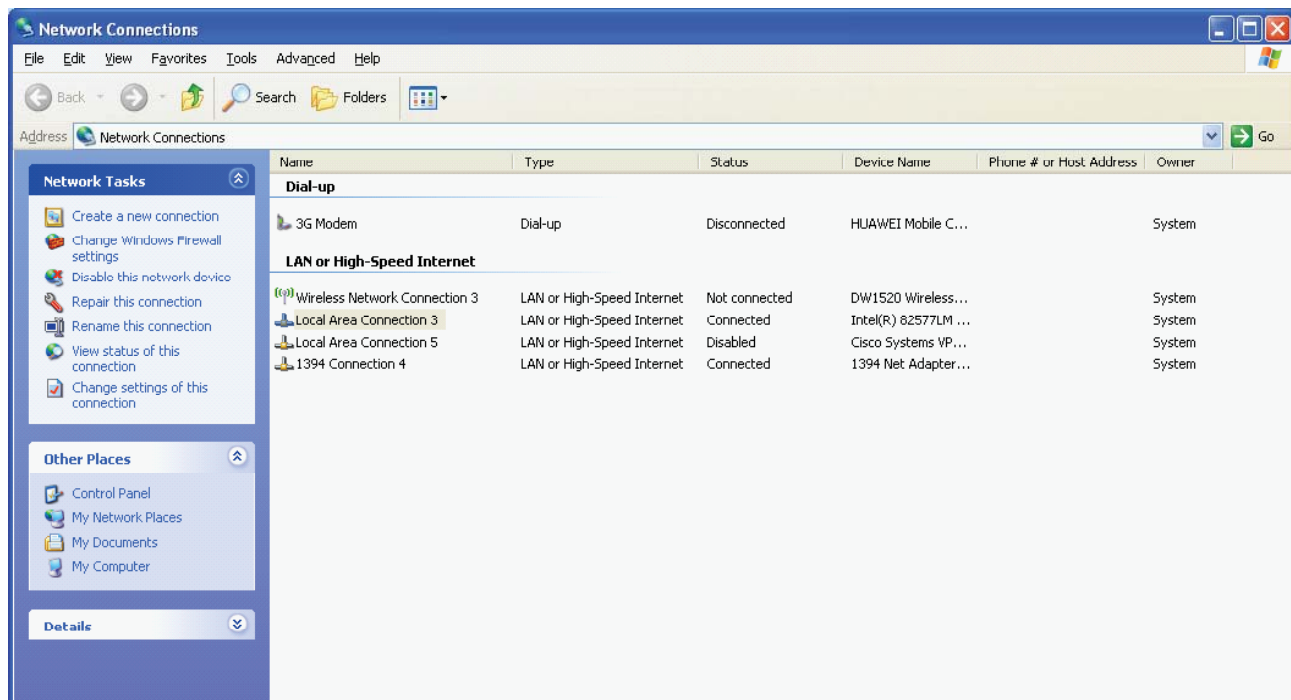

WEB ACCESS

2. Right click on the "Local Area Connection" and select "Properties".

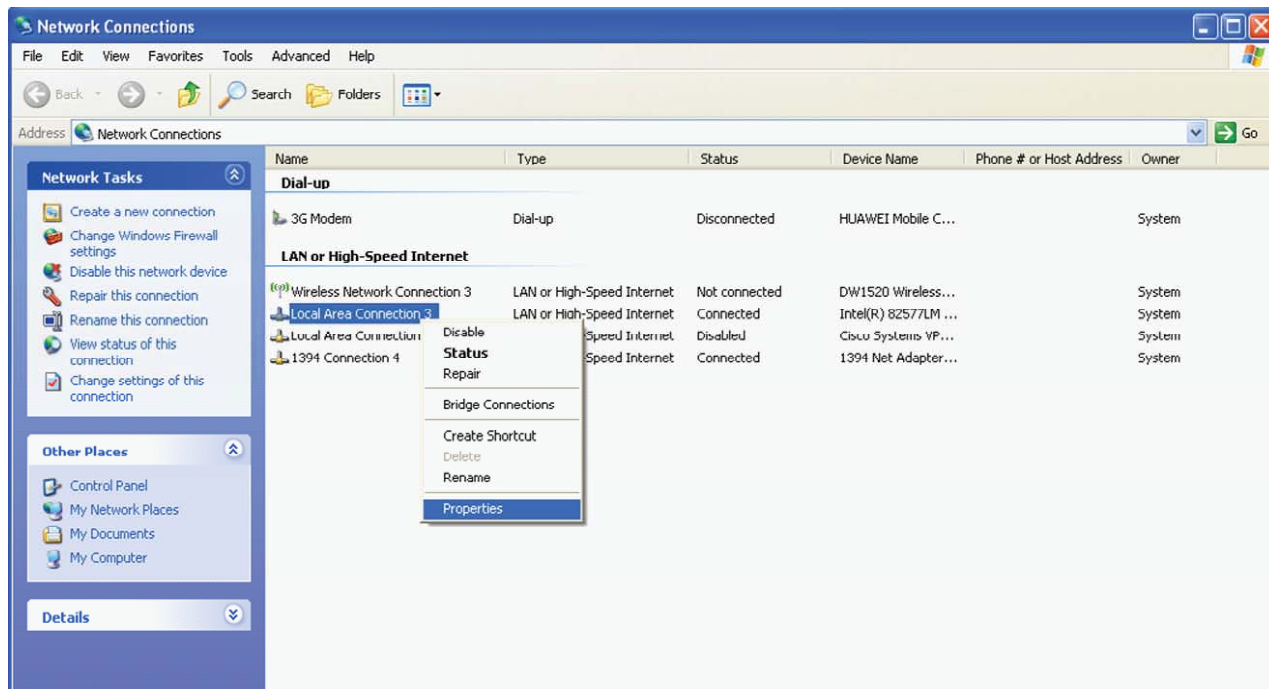

3. Scroll down the connection list to find the "Internet Protocol (TCP/IP)". Select the "Internet Protocol (TCP/IP)" and click on "Properties".

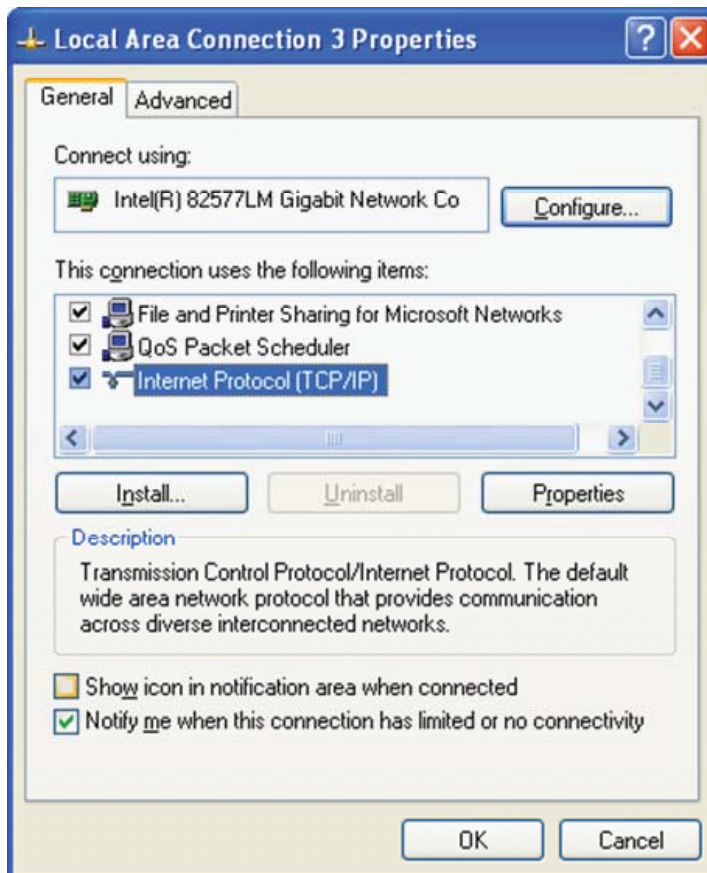

WEB ACCESS

4. Click on the "Alternative Configuration" tab.

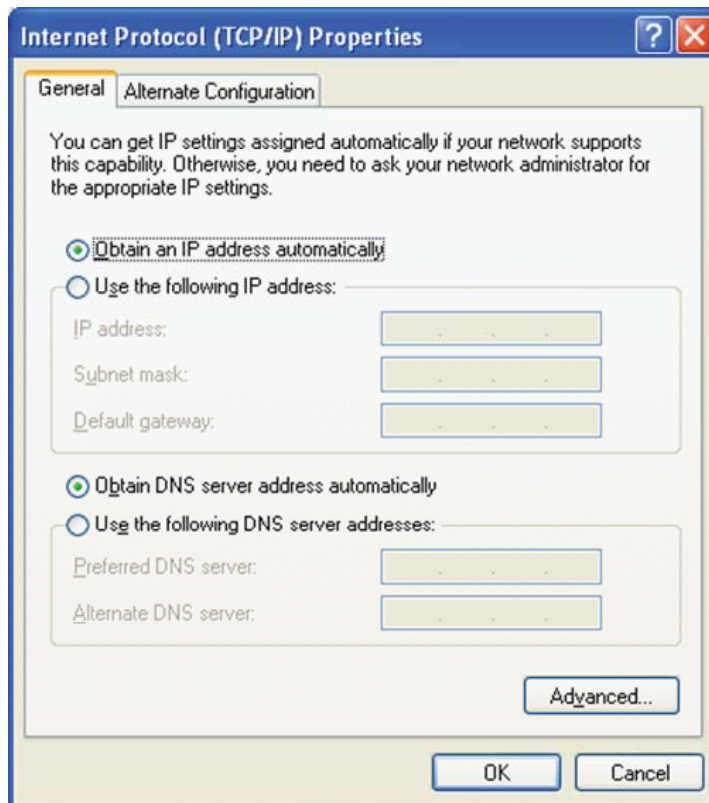

5. Click on "User Configured" Button.

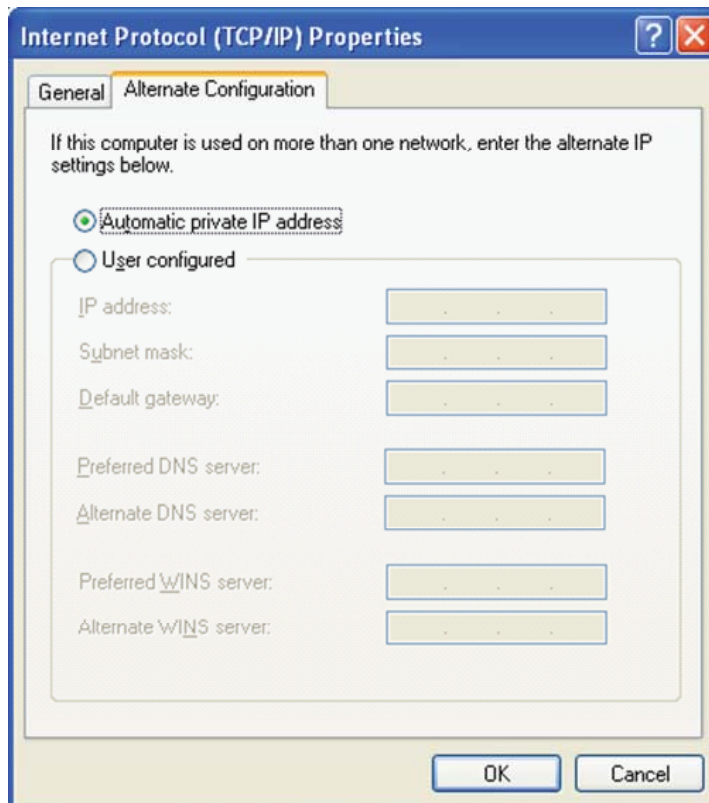

WEB ACCESS

6. Enter IP address for the computer (192.168.2.221), Enter the Subnet mask for the computer (255.255.255.0) and leave all other field boxes blank.

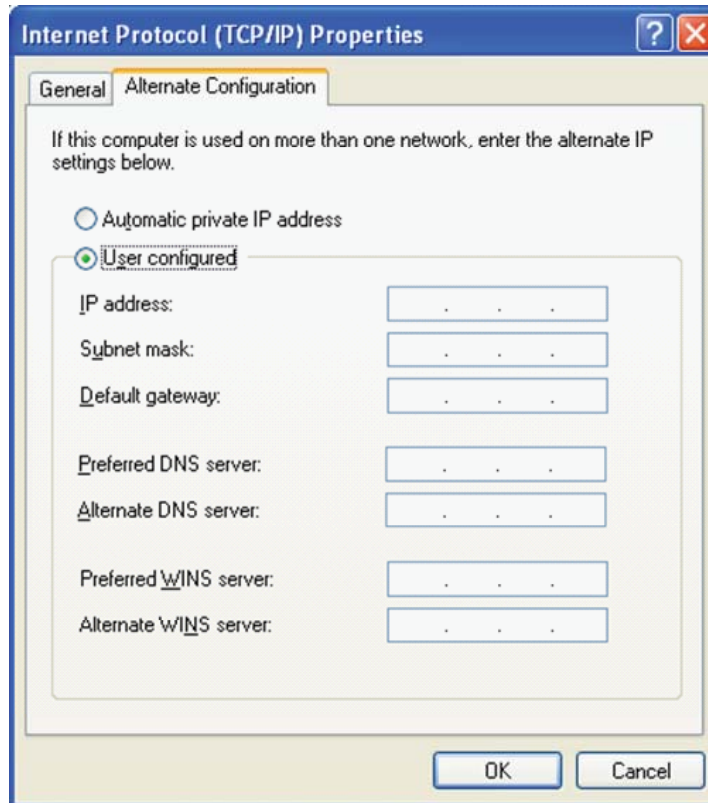

Internet Protocol (TCP/IP) Properties

General Alternate Configuration

If this computer is used on more than one network, enter the alternate IP settings below.

Automatic private IP address

User configured

IP address: . . .

Subnet mask: . . .

Default gateway: . . .

Preferred DNS server: . . .

Alternate DNS server: . . .

Preferred WINS server: . . .

Alternate WINS server: . . .

OK Cancel

7. Click on "OK" button when it is complete.

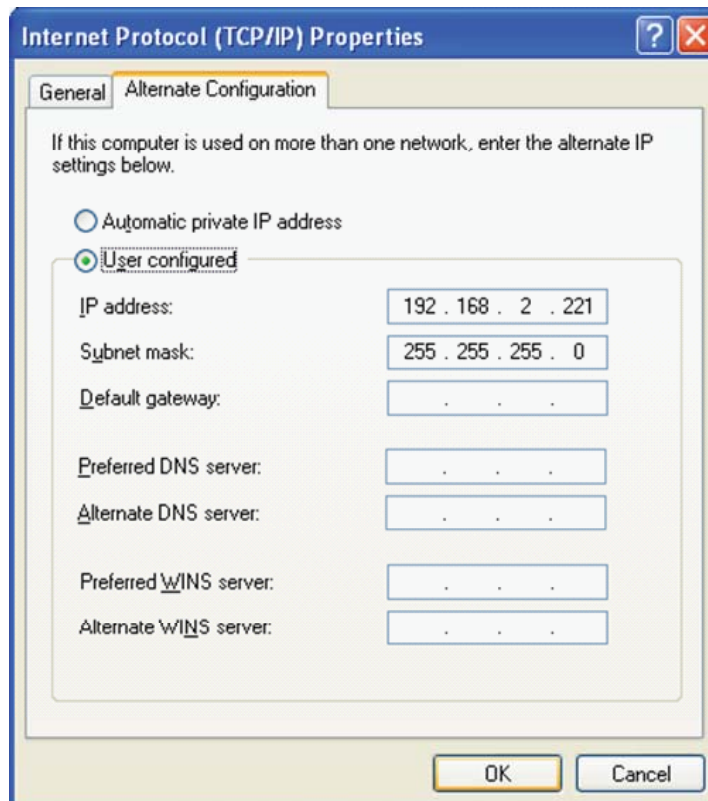

Internet Protocol (TCP/IP) Properties

General Alternate Configuration

If this computer is used on more than one network, enter the alternate IP settings below.

Automatic private IP address

User configured

IP address: 192 . 168 . 2 . 221

Subnet mask: 255 . 255 . 255 . 0

Default gateway: . . .

Preferred DNS server: . . .

Alternate DNS server: . . .

Preferred WINS server: . . .

Alternate WINS server: . . .

OK Cancel

WEB ACCESS

- Connect an Ethernet cable to your computer and to the controller. Within a minute, the computer will make a connection to the controller. Once connected, you will be able to log into and configure the controller.

ETHERNET WIRES

Wiring the network is accomplished by connecting the user computer to the controller using Category 5 (or better) cables. The connection point on the user computer is a RJ-45 port located on the Network Interface card.

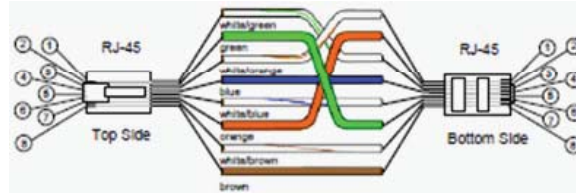

The Ethernet cables are terminated with CAT 5 RJ-45 (RJ means "Registered Jack") modular plugs. RJ-45 plugs are similar to those seen on the end of a telephone cable except they have eight versus four or six contacts on the end of the plug and they are about twice as big

ETHERNET CONFIGURATION

The Ethernet configuration allows the user to select how the controller will be connected to the LAN.

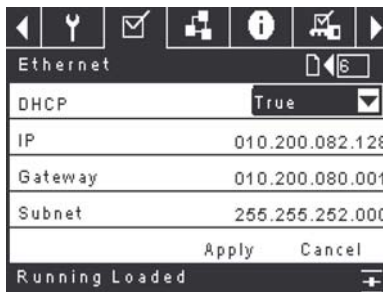

The controller ships with a default IP address of 192.168.2.220. If "Enable DHCP" option is true in the "General Settings" [screen# 7] of the controller, then it will obtain an IP address via DHCP.

Once the user changes the "DHCP Enable" option to true, the "Assigned IP" address (e.g. 10.40.193.73) will appear below this selection in few seconds. The users connected with the local area network can use this new assigned IP to login to the web pages. Please note that depending on the LAN architecture, not all users will be able to view the web pages from their PC.

CAUTION

Changing the Ethernet configuration of the controller may cause the web pages to become unresponsive and require IT or other support to return the web pages to an operational condition. Be certain all Ethernet settings are correct before saving changes.

WEB ACCESS

LOGIN PROCESS

The server is accessed either by host name or by IP. Accessing by name requires that a router be in the network. During the installation and commissioning process a network address was assigned to the CONTROLLER by your IT department.

This address may be a static IP (e.g. <http://192.168.2.220>, recommended) or a DHCP assigned domain name address (e.g. <http://fenixsim.com>). A domain name address is a web page address chosen by the user to represent the controller. The domain name must be approved by your IT department but can generally be any text label you wish. You must have this address before you can log in to the web pages. See section – Ethernet Configuration.

Please note that Web Pages requires an HTML 5 compliant browser, such as Internet Explorer 10 (or newer) or Mozilla Firefox 6 (or newer) , and Safari 5 (or newer). Certain functions may not behave correctly when using older browser software.

To log in to the web pages you must first type the address into your browser and then press the enter button. For example, with a DHCP enabled controller you might type this:

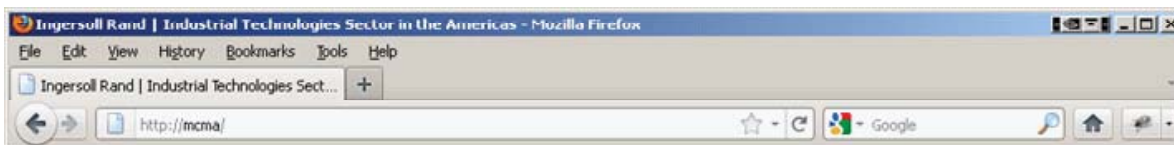

While with a static IP address you might type this:

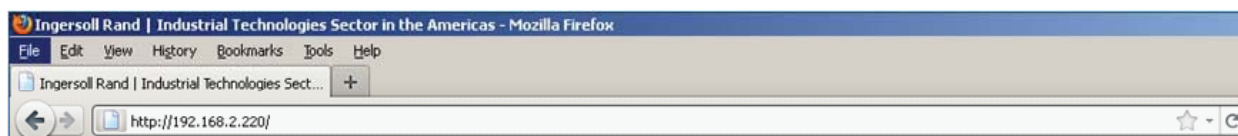

If the controller is configured correctly you will then see the web pages in your browser. This may take a few seconds depending on your network connection speed.

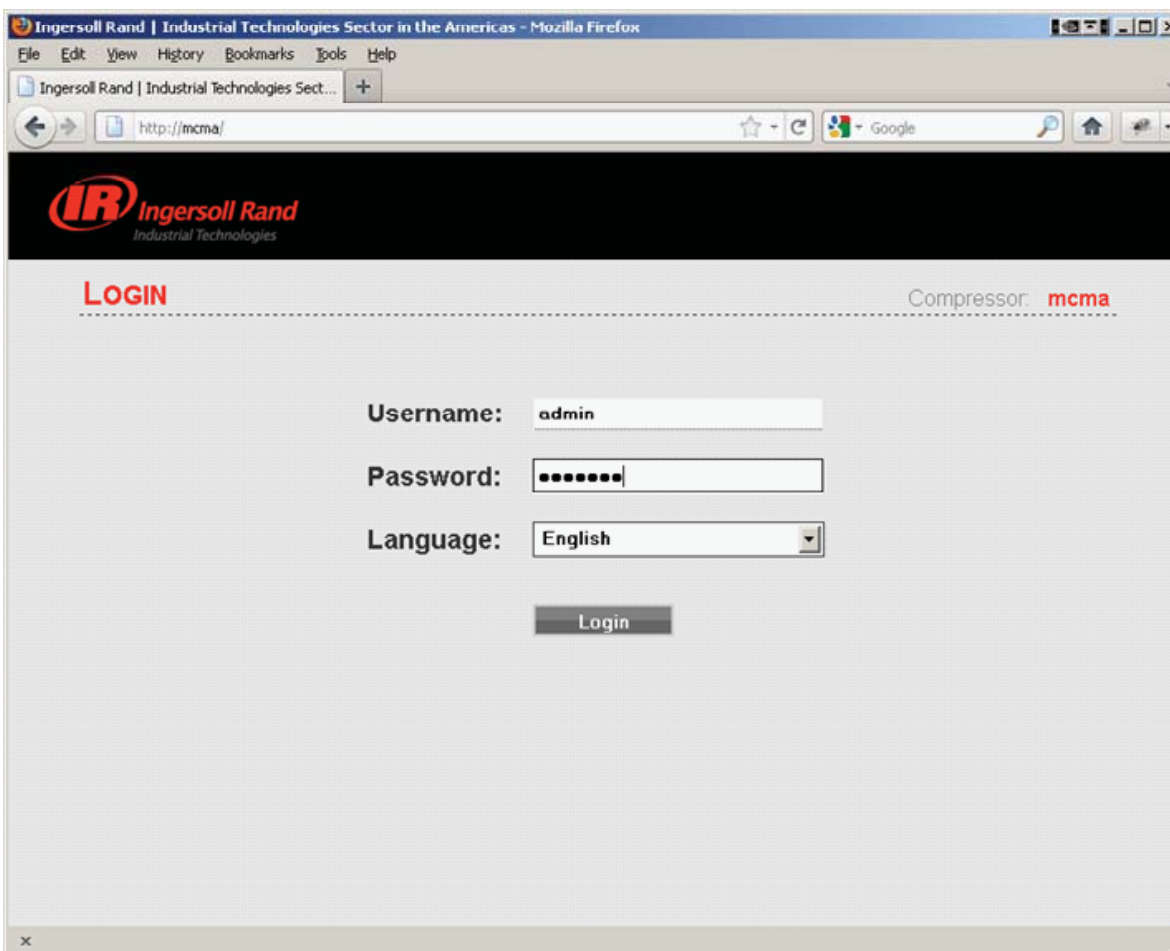

WEB ACCESS

The login screen requires the user to enter their username, password and select the language for the web pages. This login screen will authenticate the user against the type of account. After log in the user can view/modify the data as per the available access to the user account.

Enter the username & password for log into system and access the web pages.

Username: <input style="width: 200px;" type="text"/>	Type in your user name (case sensitive)
Password: <input style="width: 200px;" type="password"/>	Type in your password (case sensitive)

If the user name or password are incorrect the login page will show a message “Unknown combination of username and password”.

Click on the dropdown control and select the “Language” from language dropdown control. The full list of languages for the X^e-145M controller is supported by the web interface. The user may select one language from this list. This selection will be the language for the web interface after the login is successful.

Language: <div style="border: 1px solid black; padding: 2px;">English ▼</div> <div style="border: 1px solid black; padding: 2px; margin-top: 2px;">English</div> <div style="border: 1px solid black; padding: 2px; margin-top: 2px;">Nederlands</div> <div style="border: 1px solid black; padding: 2px; margin-top: 2px; text-align: center;">Login</div>	Select your language from the dropdown list
---	---

Click on “Login” button to continue. Upon successfully logging in you will see the system HOME screen.

The screenshot shows a web browser window displaying the Ingersoll Rand Xe-70M control interface. The address bar shows the URL 10.200.82.186/home_frame.htm. The page features a navigation menu on the left with buttons for Start, Stop, Reset Alarm, Load, and Unload. The main content area displays the word "HOME" and a list of system parameters with their current values:

Online Pressure	93 PSI
Offline Pressure	104 PSI
Package discharge pressure	107 PSI
Sump Pressure	---
Airend Discharge Temperature	27.7 °F
Separator pressure drop	---
Powered hours	0 hrs
Running Hours	0 hrs
Loaded Hours	0 hrs
Number of Starts	0
Auto-Restart	OFF
Auto-Restart Time	120 sec
Auto-Restart Delay Time	0 sec
Communication control	OFF
Remote Start-Stop	OFF
PORO	OFF
PORO Time	10 sec
Low Ambient Temperature	34.7 °F
Scheduled Start Day	Sunday
Scheduled Start Hour	0 hrs
Scheduled Start Minute	0 min
Scheduled Stop Day	Sunday
Scheduled Stop Hour	0 hrs
Scheduled Stop Minute	0 min
Integral Sequencing 1	---
Integral Sequencing 2	---
Integral Sequencing 3	---
Integral Sequencing 4	---

At the bottom of the page, a black status bar displays the word "Tripped" in white text. The Windows taskbar at the bottom shows the time as 3:09 PM and the date as 6/20/2016.



Only 5 users can concurrently login to the controller at a time. If another user attempts to login, an error message will be displayed. “The limit on the number of concurrent users has been reached. Please wait for a user to logoff before trying again.”

Please see below section for default account information, and section “ACCOUNT MANAGEMENT” for more detailed information about the account management process.

WEB ACCESS

DEFAULT ACCOUNTS

The web page software comes with default administrator account. The system administrator can assign users one of three levels of access (view only, user and administrator) which will determine which functions will be available. For example, only users with administrator access will be able to create a new user account and view or modify the configuration overview parameters.

It is highly advised that the administrator change these accounts as soon as feasible to prevent unauthorized access to the Visualization software. The three level of access rights are as follows:

- 1. VIEW :** The user is able to view information on all the screens. The user is unable to change any set points or access to the configuration overview screens.
- 2. USER :** The user has all rights available to the VIEW access level as well as being able to change setpoints on the HOME screen and working duration of the maintenance counter. The user is able to manually start, stop, load and unload the compressors, as well as reset the alarm.
- 3. ADMIN :** The user has all rights of the VIEW and USER access levels as well as full access to the configuration overview screens and the account management utility.

Please note that there can be as many as five (5) maximum users logged into the system at one time, and only one administrator logged in at one time. Only a user with ADMIN rights will be able to modify these default accounts.

The default account is:

Login	:	admin
Password	:	password
Rights	:	ADMIN

WEB ACCESS





NAVIGATION

Each of the main segments is represented by a tab on the top of web pages. Clicking on the tab will bring you to the screen for that particular segment.

TAB NAVIGATION



The components of the tab navigation are as follows:

	Home	Clicking this tab will bring the user to the HOME page. See section HOME PAGE
	Event Log	Clicking this tab will bring the user to the EVENT LOG. See section EVENT LOG UTILITY
	Maintenance	Clicking this tab will bring the user to the MAINTENANCE page. See section MAINTENANCE UTILITY
	Compressor Information	Clicking this tab will bring the user to the COMPRESSOR INFORMATION page. See section COMPRESSOR INFORMATION
	Account	Clicking this tab will bring the user to the ACCOUNT page. See section ACCOUNT MANAGEMENT





COMMAND BUTTONS

All pages show five command buttons (Start, Stop, Reset Alarm, Load and Unload), five dash board icons and current status of the compressor.

NOTICE

If the current user's account type does not have the necessary access rights to control the compressor via the web interface, remote control from the web interface will be disabled at the controller.

"Command Keys" on the web pages command the compressor to perform actions as specified in the following table.

Key	Name	Function
	Start	Start the Compressor
	Stop	Stops the compressor. This button should be pressed instead of the E-Stop for normal stopping operation.
	Reset Alarm	Clears Warnings and Trips once the condition is corrected.
	Load	Loads the compressor
	Unload	Unloads the compressor

NOTICE





Remote starting and stopping can be accomplished through the Ethernet Port. Panel power must be on, all utilities must be running and permissive functions satisfied in order for the start-up from the web page.

WEB ACCESS





DASHBOARD ICONS

“Dashboard Icons” are intended to be a quick at-a-glance view of system status. These icons are always visible regardless of the folder/page selected.

The following table lists standard dashboard icons and their definition. Note that the color of these icons changes based on the state set by the application while running.

Icons	Name	Description
	Alert	Illuminates when a Warning (flashes) or Trip (constant on) is sensed.
	Remote Control	Remote control is enabled.
	Service Required	A Service reminder is nearing or has expired (i.e. an air or oil filter needs to be changed)
	Unloaded	Compressor is in the unloaded state
	Loaded	Compressor is in the loaded state

Compressor Name, User Name, Print Button and Log Out button are always visible on the right side top of the page, regardless of the tab selected.

Compressor Name		The user can set the “Compressor Name” from the “Compressor Information” tab. The user can use this host name as a browser address for the web pages. A “Compressor Name” is a domain address to log in the CONTROLLER web pages.
Logged in User		Currently logged in user is shown on the right side top in each web page.
Print Button		Click on “Print” button, to print the content on existing web page
Log Out Button		Click on “Logout” button to terminate the current session. Clicking this button will log out the current user and return to the web page login screen.

WEB ACCESS

HOME PAGE

The "HOME" tab shows information about the compressor operating parameters, total power consumption, running hours, loaded hours, number of starts, etc

The screenshot displays a web browser window with the URL `10.200.82.186/home_frame.htm`. The page title is "HOME" and it features the Ingersoll Rand logo. A navigation menu on the left includes "Start", "Stop", "Reset Alarm", "Load", and "Unload". The main content area lists various compressor parameters:

Online Pressure	93 PSI
Offline Pressure	104 PSI
Package discharge pressure	107 PSI
Sump Pressure	---
Airend Discharge Temperature	27.7 °F
Separator pressure drop	---
Powered hours	0 hrs
Running Hours	0 hrs
Loaded Hours	0 hrs
Number of Starts	0
Auto-Restart	OFF
Auto-Restart Time	120 sec
Auto-Restart Delay Time	0 sec
Communication control	OFF
Remote Start-Stop	OFF
PORO	OFF
PORO Time	10 sec
Low Ambient Temperature	34.7 °F
Scheduled Start Day	Sunday
Scheduled Start Hour	0 hrs
Scheduled Start Minute	0 min
Scheduled Stop Day	Sunday
Scheduled Stop Hour	0 hrs
Scheduled Stop Minute	0 min
Integral Sequencing 1	---
Integral Sequencing 2	---
Integral Sequencing 3	---
Integral Sequencing 4	---

A "Tripped" status bar is visible at the bottom of the page. The Windows taskbar at the bottom shows the time as 3:09 PM.

Click on the pressure set point value in the white box, to change the "Pressure Set Point" value. Enter the new pressure set point value and click on "Confirm" button. "Pressure Set Point" is only editable parameter for the "Admin" and "User" type accounts. The user with "View" type account can't change these system parameters.

WEB ACCESS

EVENT LOG UTILITY

The "EVENT LOG" tab shows the event log from the controller. This tab contains the event log details for the system events, warnings and trips that have occurred and provides first-out indication. It also provides controls for filtering the list of events as shown. Any time an event occurs, the system will send the display to the first event log page.

Each event is added into "EVENT LOG" with a date (mm/dd), time (hh:mm:ss) and the event value. This is the value that triggered the event. The event labeled as "1" is the newest event.

The screenshot shows the "EVENT LOG" utility in a web browser. The browser address bar shows "10.200.82.186/home_frame.htm". The Ingersoll Rand logo is visible in the top left. The main content area displays a table of events with the following data:

#	Date	Time	Description
1	2015-01-17	23:48:20	Emergency Stop
2	2015-01-17	23:48:20	No translation
3	2015-01-17	23:48:20	Sensor 3APT Failure
4	2015-01-17	23:49:09	Power Up
5	2015-01-17	23:47:45	Power Down
6	2015-01-17	23:44:37	Emergency Stop
7	2015-01-17	23:44:37	No translation
8	2015-01-17	23:44:37	Sensor 3APT Failure
9	2015-01-17	23:44:26	Power Up
10	2015-01-17	23:40:13	Power Down
11	2015-01-17	23:39:41	Emergency Stop
12	2015-01-17	23:39:41	No translation
13	2015-01-17	23:39:41	Sensor 3APT Failure
14	2015-01-17	23:39:41	Reset to default configuration
15	2015-01-17	23:39:30	Power Up
16	2015-01-17	23:39:30	Reset Parameters
17	2015-01-17	23:39:30	Reset Error Log

The interface also includes a sidebar with buttons for Start, Stop, Reset Alarm, Load, and Unload. The top right corner shows user information: "User: admin | Compressor: one | Logout". The bottom of the browser window shows a Windows taskbar with a "Tripped" notification and the time 3:10 PM.

Click on the dropdown control and select the number of events per page. If the events per page are 20, then previous events will be available in the next page. Click on the "Next" button will display the previous twenty events.

WEB ACCESS

The "Event Type" dropdown allows the user to filter the list of events by event type. The user can select the type of event from the list by clicking the dropdown control. The events recorded and placed into one of three categories: Warnings, Trips/Shutdowns, and System Events. "EVENT LOG" page highlights all the trips in red text, warnings in yellow text and system events in the blue text.

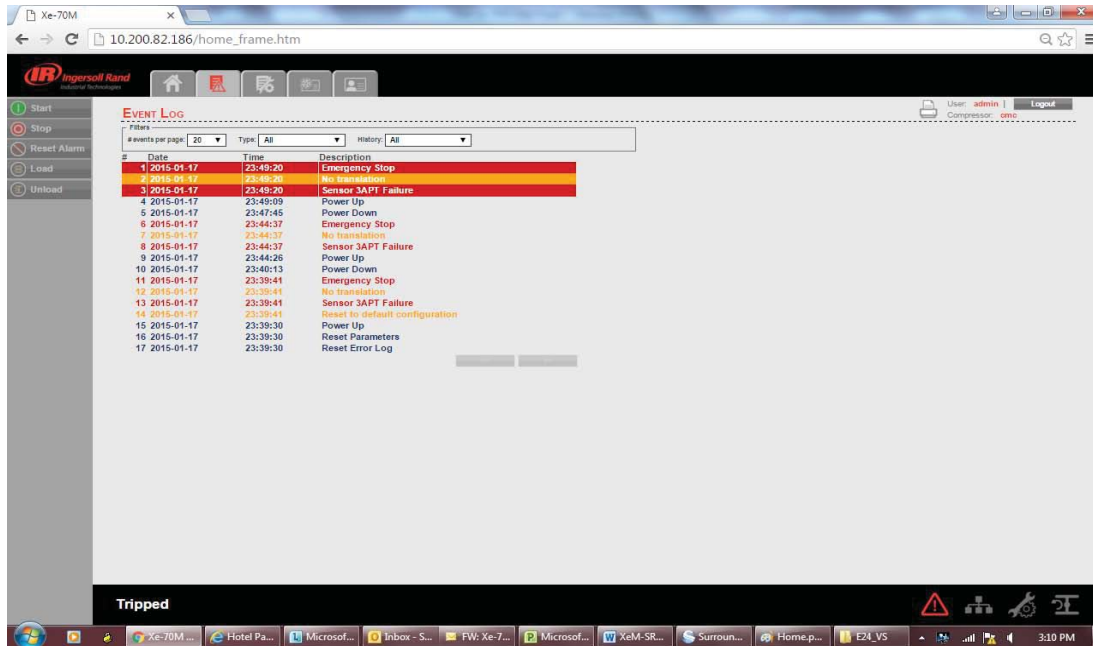

The "History" dropdown allows the user to select the option to see the event log history for a selected time period. Click on the dropdown command and select option "Last 7 Days" to see the event log of last 7 days.

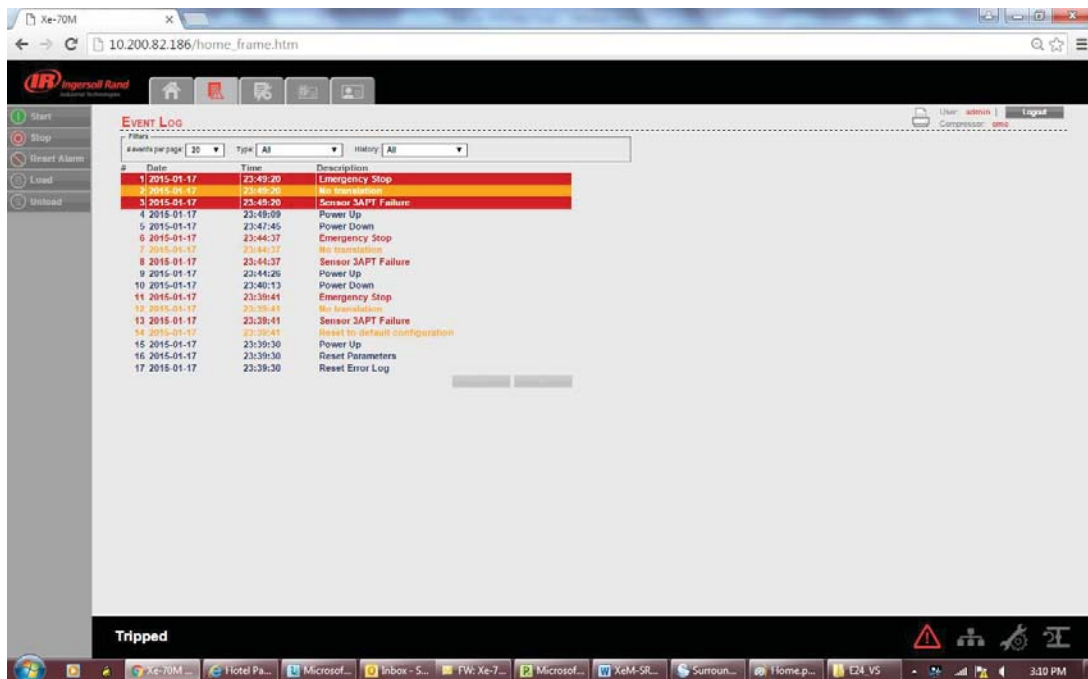

The EVENT LOG will record the last 500 events. Once this 500 event limit has been reached the oldest events will be cleared and the newest events will appear at the top of the event log.

WEB ACCESS

MAINTENANCE UTILITY

"MAINTENANCE" tab contains the service schedule hours same as shown on the "MAINTENANCE" folder of controller.

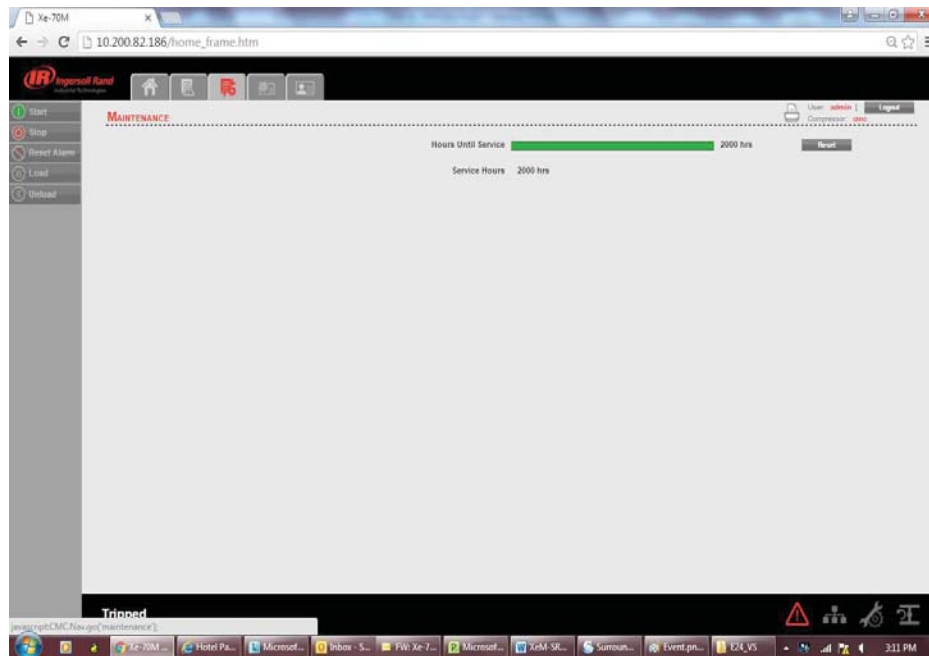

This tab provides a service scheduler so that periodic maintenance reminders may be scheduled for consumable parts.

NOTICE

"Admin" and "User" type accounts can only have an access to change the working duration of the maintenance counter and Contact details. The "View" type account can't have an access to change these parameters.

WEB ACCESS

COMPRESSOR INFORMATION

The "COMPRESSOR INFORMATION" tab contains the compressor name, compressor model number, compressor serial number, rated capacity, rated pressure, rated voltage, running current, starting current, power requirement, motor service factor, measuring units and Email (SMTP) settings.

COMPRESSOR IDENTIFICATION

The "Host Name" is shown as a "Compressor Name" on the right side top of each web page. The user can use this domain name as a web page browser address to access the web pages. To change the existing host name, enter the new hostname in the white box and click on "Submit" button.

The screenshot displays the 'COMPRESSOR INFORMATION' web page. The 'Compressor Identification' section includes the following fields and values:

- Hostname: unc
- Serial Number: 1412124198
- Compressor model number: 2422029

The 'Email (SMTP) Settings' section includes:

- SMTP Server: 141.21.124.198
- SMTP Account: vivekanand@inco...

Below these sections, there are several rows of technical specifications, each with a corresponding input field:

- CCN number ECO module: 2422029
- Software name ECO module application: ...
- software revision ECO module application: ...
- Webpage Revision: ...
- CCN number software Xe-70M: ...
- Software name Xe-70M application: ...
- Software revision Xe-70M application: ...
- Rated Capacity: ...
- Rated Pressure: ...
- Rated Voltage: ...
- Running current: ...
- Starting Current: ...
- Nominal kW (Drive Motor): ...
- Drive Motor Service Factor: ...
- Total Package kW: ...

A 'Submit' button is located at the bottom right of the form. The 'Unit type' dropdown menu is set to 'English'. The page also features a 'Tripped' status indicator at the bottom left.

Once the user will submit the new host name, the compressor name will be changed automatically on the next login.

Enter the "Serial Number" and "Model Number" as per the compressor nameplate, and click on "Submit" button to save these compressor details.

WEB ACCESS

The screenshot shows a web browser window displaying the Ingersoll Rand web interface. The page title is "COMPRESSOR INFORMATION". The interface includes a navigation menu on the left with options: Start, Stop, Reset Alarm, Load, and Unload. The main content area is divided into two sections: "Compressor Identification" and "Email (SMTP) Settings".

Compressor Identification:

- Hostname:
- Serial Number:
- Compressor model number:

Email (SMTP) Settings:

- SMTP Server:
- SMTP Account:

Other Settings:

- CCN number ECO module:
- Software name ECO module application:
- software revision ECO module application:
- Webpage Revision:
- CCN number software Xe-70M:
- Software name Xe-70M application:
- Software revision Xe-70M application:
- Rated Capacity:
- Rated Pressure:
- Rated Voltage:
- Running current:
- Starting Current:
- Nominal kW (Drive Motor):
- Drive Motor Service Factor:
- Total Package kW:

Unit type:

At the bottom of the page, a status bar indicates "Tripped" with a warning icon.

EMAIL (SMTP) SETTINGS

If email notifications are to be used, the SMTP server settings must be obtained from IT and entered in this location. Enter the "SMTP Server" & "SMTP Account" and then click on "Submit" button to save the SMTP settings.

This screenshot is identical to the one above, showing the Ingersoll Rand web interface with the "COMPRESSOR INFORMATION" section. The "Email (SMTP) Settings" section is highlighted, showing the SMTP Server and SMTP Account fields. The "Submit" button is visible below these fields. The status bar at the bottom indicates "Tripped".

NOTICE

User account with access level "Admin" can only have an access to change the parameters in "Compressor Identification" and "Email (SMTP) Settings" blocks. User account with access level "User" and "VIEW" cannot have an access to change these parameters.

WEB ACCESS

COMPRESSOR DETAILS

Enter the rated capacity, rated pressure, rated voltage, running current, starting current, nominal power in kW and main motor service factor as per the data available in the compressor datasheet.

Click on the "Submit" button to save the compressor details.

The screenshot shows a web browser window displaying the Ingersoll Rand Xe-70M control interface. The page title is "Xe-70M" and the URL is "10.200.82.186/home_frame.htm". The interface includes a navigation menu on the left with options: Start, Stop, Reset Alarm, Load, and Unload. The main content area is titled "COMPRESSOR INFORMATION" and contains several sections:

- Compressor Identification:** Fields for Hostname (cmc), Serial Number (14538557), and Compressor model number (263666), each with a "Submit" button.
- Email (SMTP) Settings:** Fields for SMTP Server (141.251.14.118) and SMTP Account (shivakumar.potagunda@ico...), each with a "Submit" button.
- Software and Configuration:** Fields for CCN number ECO module (24226038), Software name ECO module application, software revision ECO module application, Webpage Revision, CCN number software Xe-70M, Software name Xe-70M application, Software revision Xe-70M application, Rated Capacity, Rated Pressure, Rated Voltage, Running current, Starting Current, Nominal kW (Drive Motor), Drive Motor Service Factor, and Total Package kW. Each field has a "Submit" button.
- Unit type:** A dropdown menu currently set to "English".

The bottom of the interface shows a "Tripped" status indicator and a taskbar with various application icons and a system clock showing 3:12 PM.

UNIT TYPE

Click on the dropdown control and select the measurement unit type for the compressor parameters. Default unit type is "English".

NOTICE

User account with access level "Admin" and "User" can only have an access to change these compressor parameters. User account with access level "VIEW" can only monitor the data and the user can not have an access to change these parameters.

WEB ACCESS

ACCOUNT MANAGEMENT

The administrator can create any number of users desired and assign each user one of three levels of access, as well as assigning email notifications to various events that may occur.

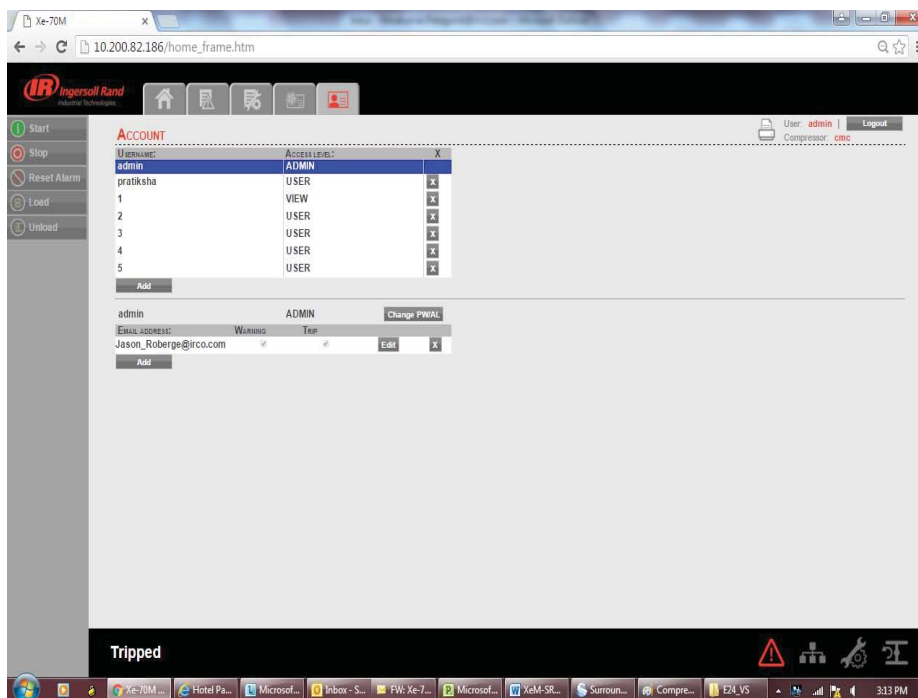

ADD ACCOUNT

The "ACCOUNT" tab shows the list of accounts that currently exist which are listed by user name and access rights. Clicking on an account will highlight that account in blue color. Click on "ADD" button to add an account with a specified access level for the web page application. Enter the ADMIN password to proceed.

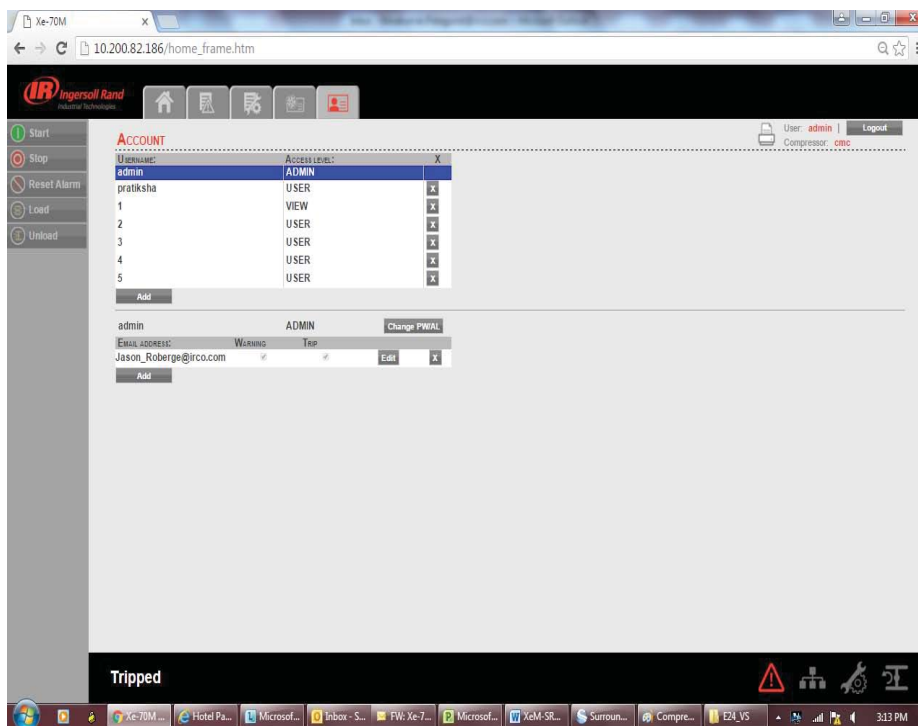

WEB ACCESS

To generate a new user account; enter the unique username, password and select the user access rights. Click on "Add Account" button will add the new user account into the list of user accounts. Only a user with "ADMIN" rights will be able to make a new account or remove the existing accounts.

Select the user account from the list and click on "X" button to delete the selected user account.

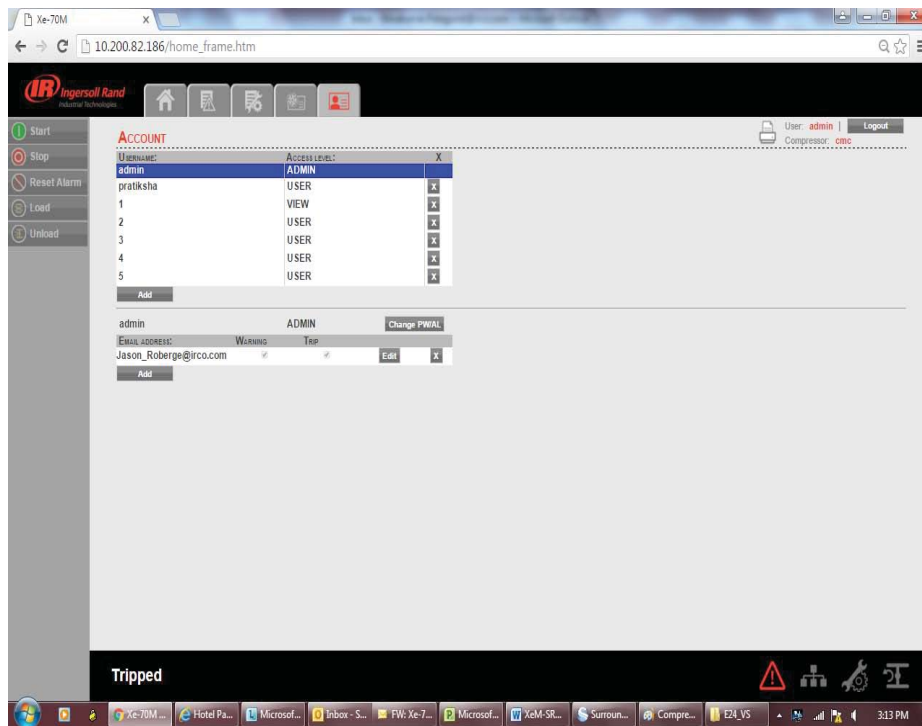

MODIFY THE ACCESS LEVEL

User account with access level "ADMIN" can also change the access level of existing user accounts. To change the access level or password of an existing user account, select the user account from the list and click the Change PW/AL button.

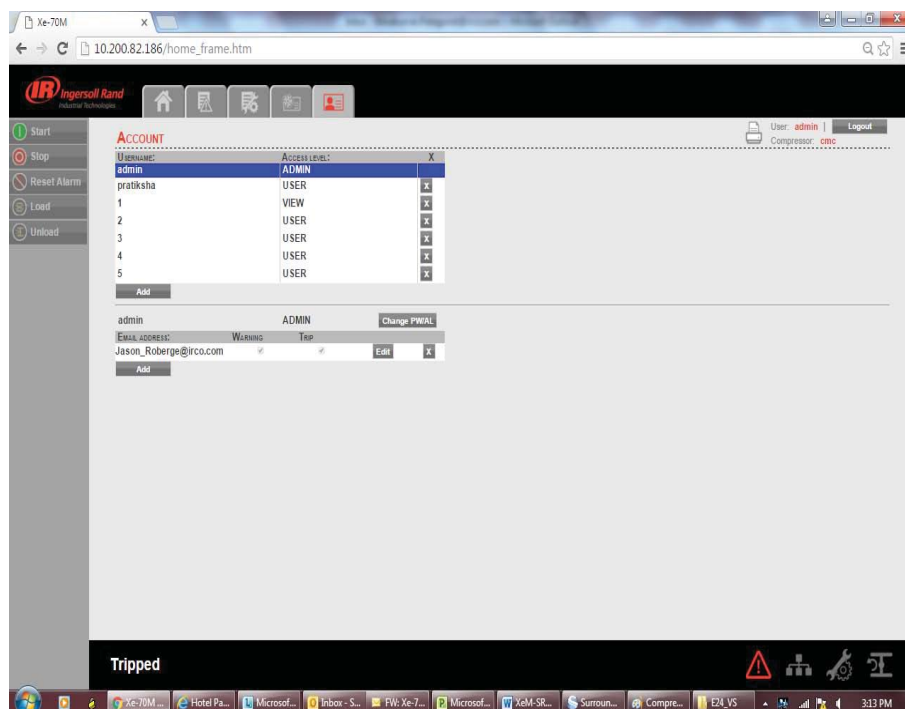

Click on the dropdown control and choose the new access level for selected user account. Again, click on "Change PW/AL" button to save the changes in access level or password for selected user account.

WEB ACCESS

Set the email address settings for the user by clicking on the "Add" button in the email list. Then type in the email address and check the boxes for the type of alerts the user should receive. When finished, press the "Submit" button.

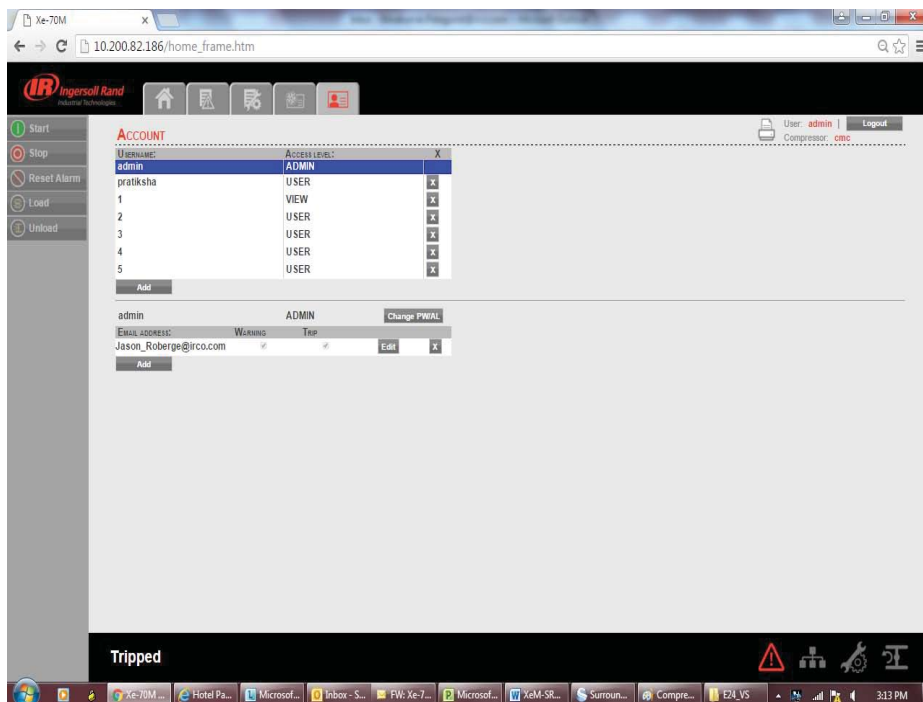
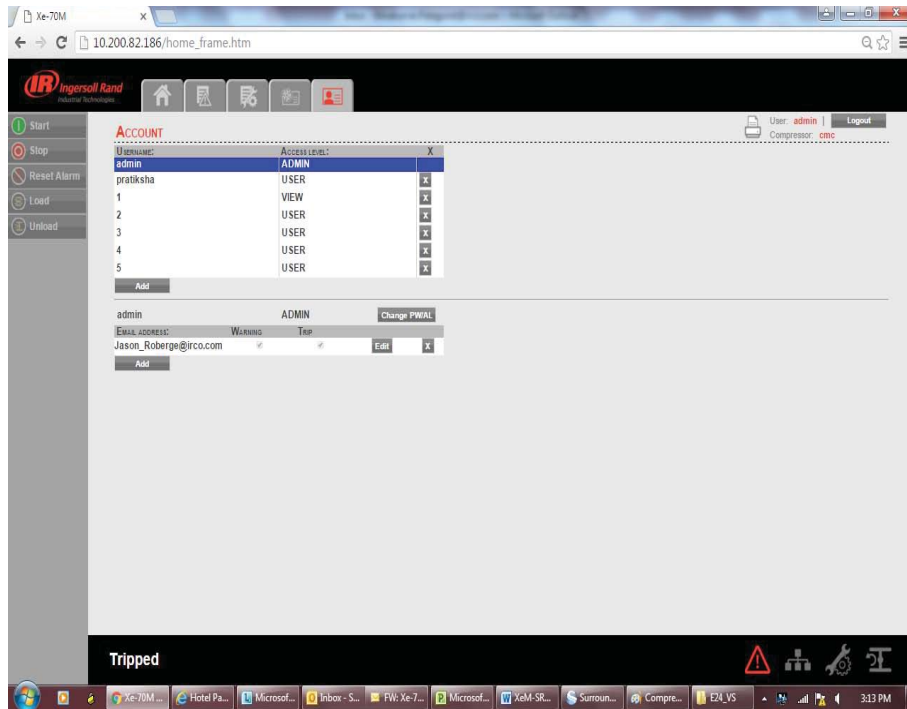

NOTICE

User account with access level "Admin" can only have an access to make a new account or modify the access level of these accounts. User account with access level "User" and "VIEW" can't have an access to make a new account or modify the user accounts.

■ R4 to 37 kW FIXED SPEED MODBUS TABLE

Table 8: R4 To 37 kW Fixed Speed MODBUS Table

Register (40XXX)	Variable	Read/Write	Range	Notes
1	Status/Control	R/W		See table 9
3	Package Discharge Pressure	R		
4	Sump Pressure	R		
7	Airend Discharge Temperature	R		
8	After-cooler Discharge Temperature	R		Low Ambient units only
10	Separator Pressure Drop	R		
16	After-cooler Discharge Pressure	R		Dryer units only
65	Running Hours MSB	R		
66	Running Hours LSB	R		
67	Loaded Hours MSB	R		
68	Loaded Hours LSB	R		
98	Rated Pressure	R		
100	Starter Type	R	1-3	See table 10
101	Modulation Enabled	R		0=Disabled
102	Service Level	R	0 - 2	0=Level 0, 1=Level 1, 2=Level 2
103	Service Time Period	R	1000 - 8000	Increments of 1000
104	Dryer Installed	R		0=OFF
112	Offline Pressure	R/W	75 - (rated+10)	rated = rated pressure
113	Online Pressure	R/W	65-(offline-10)	offline = offline pressure
114	Mode of Operation	R/W	0 - 2	See table 9
115	Starter Time (seconds)	R/W	5 - 30	
116	Auto Restart Time (seconds)	R/W	120 - 3600	
117	Auto Restart ON/OFF	R		0=OFF
118	Communication Control ON/OFF	R		0=OFF
119	Remote Start/Stop Enable	R		0=OFF
121	Power Out Restart Option (PORO) Enable	R		0=OFF
122	PORO Time (seconds)	R/W	10 - 600	
123	Auto Start/Stop Delay Time (seconds)	R/W	0 - 60	
124	Low Ambient Temperature	R/W	30 - 60	Degree F
125	Unloaded Stop Time	R/W	10 - 30	
128	Lead/Lag	R/W		0=Lag
129	Lag Offset	R/W	0 - 45	psi
131	Lead/Lag Cycle Length (Hours)	R/W	0 - 750	
132	Scheduled Start (Day)	R/W	0 - 9	See table 10
133	Scheduled Start (Hour)	R/W	0 - 23	
134	Scheduled Start (Minute)	R/W	0 - 59	
135	Scheduled Stop (Day)	R/W	0 - 9	See table 10
136	Scheduled Stop (Hour)	R/W	0 - 23	
137	Scheduled Stop (Minute)	R/W	0 - 59	
255	Warning Code	R		See table 11
256	Trip Code	R		See table 11
400	Reset Web Logins	R/W	0-1	Writing a 1 value will reset the web logins to factory defaults. After the reset is performed this value shall be set back to 0

Table 9 : Xe 70M Fixed Speed Controller Register 01-Status/Control

<p>Bit 0: Host/Local (R/W)</p> <p>0 = Local 1 = Host</p> <p>Bit 1: Run/Stop (R/W)</p> <p>0 = Stop 1 = Run</p> <p>Bit 2: Load/Unload (R/W)</p> <p>0 = Unload 1 = Load</p> <p>Bit 3: Modulating (R) **</p> <p>0 = Not Modulating 1 = Modulating</p> <p>Bit 4: Unused</p> <p>Bit 5: Stopped in Auto Restart (R)</p> <p>0 = Not Stopped in Auto Restart 1 = Stopped in Auto Restart</p>	<p>Bit 6: Alarm (R)</p> <p>0 = No Alarms 1 = Alarms</p> <p>Bit 7: Warning (R)</p> <p>0 = No Warnings 1 = Warnings</p> <p>Bit 8: On/Off Line Mode (R)</p> <p>0 = Not in On/Off Line Mode 1 = On/Off Line Mode</p> <p>Bit 9: Mod/ACS or Mod Only (R) **</p> <p>0 = Not in Mod/ASC Mode 1 = Mod/ASC Mode</p> <p>Bits 10-12: Unused</p> <p>Bits 13-15: Unit Type (R): Unused</p>
---	--

Table 10 : Xe 70M Fixed Speed Controller Register Codes

<p>Register 100: Starter Type</p> <p>1 = Star-Delta 2 = Remote Starter 3 = Soft Starter</p>	<p>Register 114: Mode of Operation</p> <p>0 = On/Off Line 1 = MOD/ACS ** 2 = Modulation Only **</p>
<p>Registers 132, 135: Day</p>	
<p>0 = Sunday 1 = Monday 2 = Tuesday 3 = Wednesday</p>	<p>4 = Thursday 5 = Friday 6 = Saturday</p>
	<p>7 = Daily 8 = Weekdays 9 = Weekends</p>

Table 11 : Xe 70M Fixed Speed Controller Trip & Warning Codes

Code	Description
02**	Sensor Failure 3APT
03	Sensor Failure 4APT
08**	Sensor Failure 7APT
10	Sensor Failure 2ATT
11**	Sensor Failure 7ATT
18	Motor Overload (Main) –due to CTs
19	Overload –due to Thermal OL
22**	Check Motor Rotation
25	Remote Stop Failure
26	Remote Start Failure
28**	Low Sump Pressure
29	High Air Pressure
31	High Airend Discharge Temperature
32	Emergency Stop
34**	Change Separator Element
36	Sensor Error (Calibration)
38	100 Hours To Service
39	Service Required
40	Alarm –Service Required
48	Unit Too Cold To Start
49**	High Sump Pressure
51**	Dryer High Pressure
52	Dryer Temperature Warning
55	Change HE Filter (Dryer)
56	Sensor Failure –Main Motor CT Inputs

Note that (**) Marked bits and codes are not applicable for R4-11 packages

■ R5.5 to 37 kW VARIABLE SPEED MODBUS TABLE

Table 12 : R5.5 TO 37 kW Variable Speed MODBUS Table

Register (40XXX)	Variable	Read/Write	Range	Notes
1	Status/Control	R/W		See table 13
3	Package Discharge Pressure	R		
10	After-cooler Discharge Pressure	R		
12	Airend Temperature	R		
19	Separator Pressure Drop	R		
20	Percent Capacity	R		
25	Motor Speed	R		
26	Motor Current	R		
28	DC Link Voltage	R		
30	Motor Voltage	R		
31	Package kW	R		
32	kW Hours	R	0 - 999	Add to (mW hours * 1000)
65	Total Hours MSB	R		
66	Total Hours LSB	R		
98	Compressor Type	R		See table 14
99	Service Level	R	0 - 2	0=Level 0, 1=Level 1, 2=Level 2
100	Service Time Period	R	1000 - 8000	Increments of 1000
103	Dryer Installed	R		0 = no dryer
112	Target Pressure	R/W	65 - 145	
113	Auto Stop Pressure	R/W	(T+1)-(T+10)	T = target pressure
114	Immediate Stop Pressure	R/W	ASP-(ASP+10)	ASP = auto stop pressure
117	Compare Savings To	R/W	0 - 2	0=Geo, 1=Mod, 2=ON/OFF
121	Communication Control ON/OFF	R		0=OFF
122	Remote Start/Stop ON/OFF	R		0=OFF
123	Power Out Restart Option (PORO) ON/OFF	R		0=OFF
124	PORO Time (seconds)	R/W	10 - 600	See table 14
127	Scheduled Start - Day	R/W	0 - 9	See table 14
128	Scheduled Stop - Day	R/W	0 - 9	
129	Scheduled Start (Hour)	R/W	0 - 23	
130	Scheduled Start (Minute)	R/W	0 - 59	
131	Scheduled Stop (Hour)	R/W	0 - 23	
132	Scheduled Stop (Minute)	R/W	0 - 59	
133	Rated Pressure	R		
251	VSD Software Version Number	R		Divide by 100
255	Warning Code	R		See table 15
256	Alarm Code History	R		See table 15
400	Reset Web Logins	R/W	0-1	Writing a 1 value will reset the web logins to factory defaults. After the reset is performed this value shall be set back to 0

Table 13 : Xe 70M Variable Speed Controller Register 01-Status/Control

<p>Bit 0: Host/Local (R/W)</p> <p>0 = Local 1 = Host</p> <p>Bit 1: Run/Stop (R/W)</p> <p>0 = Stop 1 = Run</p> <p>Bit 2: Load/Unload (R/W)</p> <p>0 = No Loaded Operation 1 = Loaded Operation</p> <p>Bit 3: Operating at Minimum Speed (R)</p> <p>0 = Operating above Minimum Speed 1 = Operating at Minimum Speed</p> <p>Bit 4: Operating at Maximum Speed (R)</p> <p>0 = Operating below Maximum Speed 1 = Operating at Maximum Speed</p> <p>Bit 5: Stopped in Auto Restart (R)</p> <p>0 = Not Stopped in Auto Restart 1 = Stopped in Auto Restart</p>	<p>Bit 6: Alarm (R)</p> <p>0 = No Alarms 1 = Alarms</p> <p>Bit 7: Warning (R)</p> <p>0 = No Warnings 1 = Warnings</p> <p>Bits 8-9: Normal/Unload Operate (R)</p> <p>00 = Unloaded Operation 11 = Normal Operation</p> <p>Bits 10-11: Unused</p> <p>Bit 12: Fixed/Variable Speed Compressor (R)</p> <p>0 = Fixed Speed 1 = Variable Speed</p> <p>Bits 13-15: Unit Type (R): Unused</p>
--	---

Table 14 : Xe 70M Variable Speed Controller Register Codes

Register 98: Compressor Type		
55 = 5.5 kW		
75 = 7.5 kW		
80 = 7.5 hp		
100 = 10 hp		
110 = 11 kW		
150 = 15 kW		
200 = 20 hp		
220 = 22 kW		
290 = 30 hp		
300 = 30 kW		
400 = 40 hp		
370 = 37 kW		
500 = 50 hp		
Register 127 & 128:Day		
0 = Sunday	4 = Thursday	7 = Daily
1 = Monday	5 = Friday	8 = Weekdays
2 = Tuesday	6 = Saturday	9 = Weekends
3 = Wednesday		

Table 15 : Xe-70M Variable Speed Controller Trip & Warning Codes for MODBUS Communication

Code	Description	Code	Description
01	Sensor Failure 4APT	134	VSD Fault 34
10	Sensor Failure 2ATT	135	Unused
18	High VSD Temperature	136	VSD Fault 36
19	Blower Fault	137	Unused
20	VSD Communication Failure	138	VSD Fault 38
23	Stop Failure	139	Unused
25	Remote Stop Failure	140	VSD Fault 40
26	Remote Start Failure	141	VSD Fault 41
27	Incorrect VSD Type	142	VSD Fault 42
29	High Air Pressure	...	Unused
31	High Airend Discharge Temperature	147	VSD Fault 47
32	Emergency Stop	148	VSD Fault 48
36	Invalid Calibration	149	VSD Fault 49
37	Check Set Points (Parameter Reset to Defaults)	150	AMA Not OK
38	100 Hours To Service	...	Unused
39	Service Required	159	VSD Fault 59
40	Alarm –Service Required	160	Unused
51	Dryer High Pressure	161	VSD Fault 61
52	Dryer Temperatures Warning	162	VSD Fault 62
55	Change HE Filter	163	VSD Fault 63
100	VSD Fault (generic)	164	VSD Fault 64
101	VSD Fault 1	165	VSD Fault 65
102	VSD Fault 2	166	VSD Fault 66
103	VSD Fault 3	167	VSD Fault 67
104	VSD Fault 4	168	VSD Fault 68
105	VSD Fault 5	169	Unused
106	VSD Fault 6	170	VSD Fault 70
107	VSD Fault 7	171	VSD Fault 71
108	VSD Fault 8	172	VSD Fault 72
109	VSD Fault 9	...	Unused
110	VSD Fault 10	180	VSD Fault 80
111	VSD Fault 11	...	Unused
112	VSD Fault 12	190	VSD Fault 90
113	VSD Fault 13	191	VSD Fault 91
114	VSD Fault 14	...	Unused
115	VSD Fault 15	210	KTY Error (VSD Fault)
116	VSD Fault 16	211	Fans Error (VSD Fault)
117	VSD Fault 17	212	ECB Error (VSD Fault)
...	Unused	213	Broken Belt (VSD Fault)
123	VSD Fault 23	214	Clock Failure (VSD Fault)
124	VSD Fault 24	215	End of Curve(VSD Fault)
125	VSD Fault 25		
126	VSD Fault 26		
127	VSD Fault 27		
128	VSD Fault 28		
129	VSD Fault 29		
130	VSD Fault 30		
131	VSD Fault 31		
132	VSD Fault 32		
133	VSD Fault 33		

X-SERIES SYSTEM CONTROLS CONNECTION

The Xe-70M controller is designed to interface to an **Ingersoll Rand X-Series System Controller** using Belden 9841 or equivalent RS-485 cable. In order to connect to the network, the cable must be connected to port X04 on the controller as shown in the diagrams below. Note that up to 8 (X8I) or 12 (X12I) devices can be daisy chained together in an X-Series network.:

Figure 57 : Phoenix 2 Pin Connector

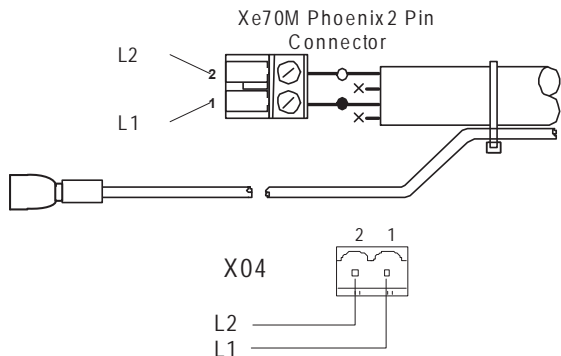

■ RS-485 NETWORK

RS-485 data communications and other low voltage signals can be subject to electrical interference.

This potential can result in intermittent malfunction or anomaly that is difficult to diagnose. To avoid this possibility always use earth shielded cables, securely bonded to a known good earth at one end. In addition, give careful consideration to cable routing during installation.

1. Never route an RS-485 data communications or low voltage signal cable alongside a high voltage 3- phase power supply cable. If it is necessary to cross the path of a power supply cable(s), always cross at a right angle.
2. If it is necessary to follow the route of power supply cables for a short distance (for example: from a compressor unit to a wall along a suspended cable tray) attach the RS-485 or signal cable on the outside of an earthed cable tray such that the cable tray forms an earthed electrical interference shield.
3. Where possible, never route an RS-485 or signal cable near to equipment or devices that may be a source of electrical interference (for example: 3-phase power supply transformer, high voltage switchgear unit, frequency inverter drive module, radio communications antenna).

Figure 58

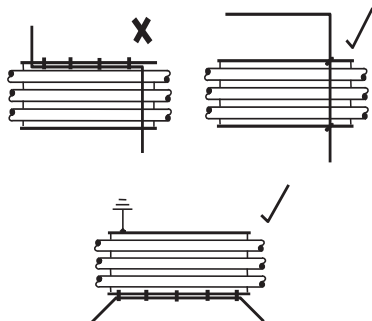

■ RS-485 ADDRESS SELECTION

Each compressor connected to the network will have a unique assigned address, starting at compressor 1 increasing sequentially to the number of compressors connected to the network.

The RS-485 address for each compressor is set on the General Settings Tab, Page 7. The controller's default RS-485 Address setting is 1

Additionally, the active protocol must be set to Airbus485.

Figure 59 : Protocols

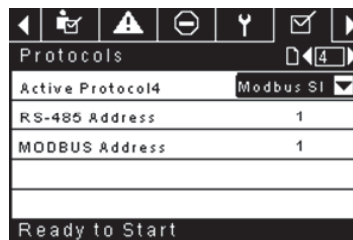

■ ENABLING SYSTEM CONTROL CAPABILITIES

In order to communicate properly with the X-Series system controller, the Xe-70M must have the following setpoints correctly set.

On the Operator Settings tab, page 3 (Fixed Speed) or page 2 (Variable Speed).

Verify that the COM control setpoint is enabled (Checkbox is filled in) as shown below. If this setpoint is not selected, the system controller will be unable to load or unload the machine.

Additionally, for fixed speed machines, make sure that the Enable Auto-Restart setpoint is enabled (checkbox is filled in) or the compressor will continue to run when unloaded by the system controller.

Figure 60 : Options

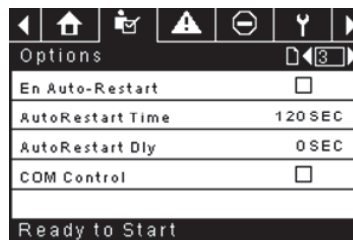

After the address and COM control have been set, be sure that Integral Sequencing is disabled by navigating to Integral Sequencing, page 1 and verifying that the Integral sequencing setpoint is disabled (checkbox not filled in) as shown below:

Figure 61: Setup

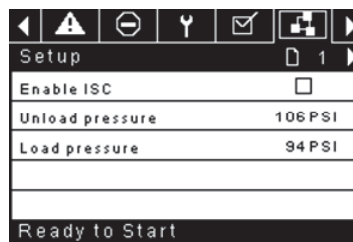

Once these setpoints are correctly set and the machine is started locally, the system controller should see status information from the compressor and be able to take control.

OPERATING INSTRUCTIONS (XE-50M CONTROLLER)

Figure 62 : Xe-50M

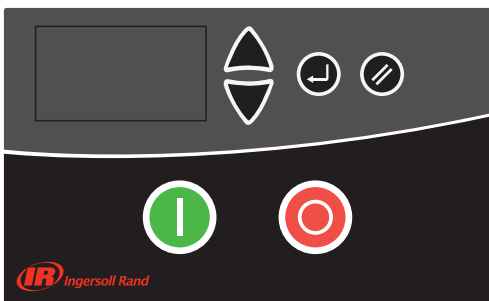

COMMAND KEYS

These keys command the controller to perform actions as specified in the following table. When any of these keys are pressed the action below will be initiated and logged in the event log.

Table 16: Xe-50M Command Keys

Icon	Name	Function
	Start	Starts the compressor.
	Stop	Stops the compressor, this button should be pressed instead of the E-stop for normal stopping operation
	Navigation Keys	Leads the user down or up a navigation path
	Reset	Clears Warnings and Trips once the condition is corrected
	Enter	Confirms operation

DISPLAY LAYOUT

Figure 63 : Display Layout

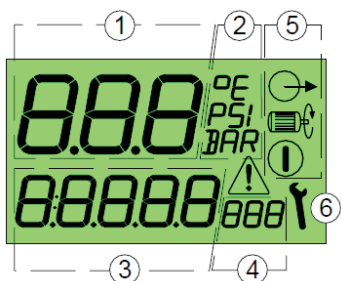

Table 17 : Display Icons

Key	Description
1	Main Display Value
2	Main Display Value Units
3	User Menu Item Display Value
4	User Menu Item Display Units
5	Status Symbols Started, Running, Loaded
6	Service/Fault Symbols Service, Fault: Alarm/Warning/Trip
	Started

Key	Description
	Running
	Loaded
	Service
	Fault: Warning Trip

USER DISPLAY

Table 18: User Display Icons

	Main Display Value : Pressure (bar/psi menu selectable)
	Default User Menu item : Temperature (°C/°F menu selectable)
	To view alternative user menu items Press Up or Down
	Total Run Hours
	Total Run Onload
	Hours Until Service Due (countdown timer based on total run hours)
	RS485 Communication Network Address (*only show if RS485 option installed)

If a timer event occurs (run-on, stop, blowdown or auto restart time) the User item display will show the time countdown in seconds. While a countdown is being displayed normal User items can still be viewed; press Down.

The display will default back to the User Temperature item after a short period of no key activity or after a timer events has completed.

If operating in 'Pressure Switch Mode' the main display will show the detected temperature and the default User Menu item will be total run hours. Pressure is not displayed in pressure switch mode.

Pressure Switch Mode

STATUS DISPLAY

The operating status is continuously displayed using status symbols.

Table 19 : Status Display Icons

	Standby : The compressor is in a started state but not running. The compressor will automatically re-start and load when pressure falls to the lower pressure set point; or a remote load signal.
	Running : The compressor is running offload (run-on-time active)
	Loaded : The compressor is running onload



■ **FAULT CONDITIONS**

 If a Fault condition occurs the Fault triangle symbol will switch ON steady (Warning) or flash (Trip). The user menu display item will show a 'Fault Code' dependant on the fault.

 Fault Codes.



■ **SERVICE DUE COUNTDOWN TIMER**

 If the service due countdown timer reaches 0 (Zero) hours the Service and Alarm symbols will flash and the service Alarm (Warning) code will be displayed. The Alarm code can be reset but the service symbol will remain on the display until the service due timer is reset; the service hours will continue to decrement in negative hours. The service countdown timer can be reset, using the menu routine, when the required service has been carried out. Set to any value greater than 0 (Zero) hours before reset.

■ **MENU ROUTINE**

Parameters, Values and Options can be adjusted and set using the Menu Routines. These are two menu lists:

1. Operational Menu - Access Code "0009"
2. Configuration Menu - Accessable just for **Ingersoll Rand** authorised service personel.

	<p>To access a menu, Stop the compressor first, then press the Up and Down buttons simultaneously. After several seconds the display will show four "0" characters; the first character will flash. Press Up and Down to adjust the first character to match the first character of the required access code. Press Enter to increment to the second code character.</p>
	<p>When all four character has been set, and the last code character is flashing, press Enter. If the access code is correct for the access to one of the two menus the first menu item of the appropriate menu will be displayed. If the access code is incorrect the display will return to the normal operational display.</p> <p>To select a menu item for adjustment press Up or Down until the menu item is displayed. To adjust an item setting press 'Enter', the value or option will flash. Press Up or Down to adjust as required then press Enter to store in memory.</p>
	<p>To exit a menu and return to the normal operational display, at any time, Press Reset.</p> <p>Any adjustment that has not to be entered to memory will be abandoned and previous setting maintained.</p>

■ **OPERATIONAL MENU**

Table 20 : Operational Menu

Item		Description
1	1.Pu	Upper Pressure Set Point
2	1.PL	Lower Pressure Set Point
3	1.Sd	Motor Star/Delta Time
4	1.P-	Pressure Display Unit
5	1.t-	Temperature Display Unit
6	1.LS	Load Source
7	1.SS	Start Source

The compressor will maintain pressure between the set Pu (Unload Pressure Set Point) and (PL) (Load Pressure Set Point). When Pressure reaches the set 'Pu' level the compressor will unload. When pressure falls to the 'PL' level the compressor will load.

NOTE:

- **Do not change factory setting of the upper and lower pressure set points**
- **For TAS version machines maximum operating pressure cannot exceed rated discharge pressure.**
- **Do not change factory setting of Auto Restart Time.**

• **Load Source**

Shall be set to 0 for local operation and to 2 for remote control (remote load/unload) using controller digital inputs C3 and C6 and external dry contacts.

• **Start Source**

Shall be set to 0 for local operation and to 2 for remote control (remote start/stop command) using controller digital inputs C3 and C6 and external dry contacts

• **Remote Start/Stop Input:**

Machine can be started/stopped remotely via digital input C3 and C6. Start Source 1.SS set to 2 (2:dIn)

In order to put the machine in local operation, 1.d3 to be set for 0 (0:Ano) and 1.S5 to be set for 0.

• **Remote Load/Unload Input:**

Machine can be loaded/unloaded remotely via digital input C3 and C6. P Load Source 1.LS set to 2 (2:dIn)

In order to put the machine in local operation, 1.d6 to be set for 0 (0:Ano) and 1.LS to be set for 0.

■ FAULT CODES

Fault codes are separated in two categories:

A : Warning - symbol illuminated on steady, the compressor will continue to operate



Table 21 : Warning Codes

A:2040	Freeze warning (Dryer Package Only)	(DI-C4)
A:2050	Dryer High Pressure (Dryer Package Only)	(DI-C5)
A:2118	High Pressure : alarm limit exceeded	
A:2128	High Temperature : alarm limit exceeded	
A:2816	Power failure detected	
A:3123	Run Inhibited - temperature is below set low temperature run inhibit limit (will self reset when temperature increases above the set temperature limit; cannot be manually reset)	
A:3423	Load Inhibited - temperature is below set low temperature run inhibit limit (will self reset when temperature increases above the set temperature limit; cannot be manually reset)	
A:4804	Service Due - Service interval hours counter has reduced to zero	
A:3129	Airend Discharge Temperature is above 103 °C	

E : Trip - symbol will flash, the compressor will stop



Table 22 : Trip Codes

E:0010	Emergency Stop - 24 Vac is not being detected on terminal R1C	
E:0020	Main or Blower Motor Overload	(DI-C2)
E:0115	Pressure Sensor Fault: 4-20mA signal out-of-range (<3.8mA or >20.8mA)	
E:0119	Excess Pressure : shutdown limit exceeded	
E:0125	Temperature Sensor Fault : signal out-of-range (<50 °C or > 250 °C)	
E:0129	Excess Temperature : shutdown limit exceeded	
E:0866	Power Supply 24V DC low	
E:0821	Power Supply Analog Inputs Low	
E:0030	Remote start failure	
E:0060	Remote stop failure	

■ X-SERIES SYSTEM CONTROLS CONNECTION

Xe50M now supports system controller communication using Digital Input C3 and C6 and digital output R1 and R2 through IR-PCB interface module.

Please note that XE50m does not support communication through RS485.

Remote Start/Stop:

When 1.SS is set to 2, DI C3 shall act as remote start, DI C6 shall act as remote stop. When 1.SS is set to 2, 1.LS will be automatically set to 0 (local only) and it will be a mutually exclusive setting.

Remote Load/Unload:

When 1.LS is set to 2, DI C6 should act as load/unload input, DI C3 acts as remote load enable. When 1.LS is set to 2, 1.SS will be set to 0 (local only, no remote start allowed for remote load/unload to work).

■ ENABLING SYSTEM CONTROL CAPABILITIES

To enable remote operation, X03 DI C3 should be connected to 202: Load enable port of IR-PCB interface module and X03 DI C6 should be connected to 220: Load/Unload port of IR-PCB interface module. Also X04 DO R1 should be connected to 120: READY and X04 DO R2 should be connected to 113: RUN port of IR-PCB interface module.

OPERATING INSTRUCTIONS FOR INTEGRATED DRYER

■ INTRODUCTION

This manual is an integral part of the dryer you bought, and must remain with the machine even if this will be resold.

It is highly recommended that the qualified* personnel for installation maintenance and/or control will fully comply with the contents of this manual and the prevention and safety rules in force in the country where the system will be used. In this way, not only the usage of the machine will be rational, but also the service will result cost effective.

In case your dryer will present any kind of problem, please contact your local authorized **Ingersoll Rand** distributor.

Note that, when necessary, the use of original spare parts will ensure efficiency and long duration to your dryer.

Due to the continuous technological evolution, **Ingersoll Rand** reserves the right to modify the specifications contained in this manual without giving previous notice.

■ SYMBOLS AND LABELS USED IN THE MANUAL AND ON THE DRYER

Table 23 : Symbols and Labels

	Pay particular attention to the indications preceded by these symbols.
	Air inlet / outlet
	Air inlet / outlet
	Air inlet / outlet
	Air inlet / outlet
	Air outlet
	Air inlet.
	Read the Operators manual before attempt to start up the machine and to perform any service operation on the dryer.
	Installation, maintenance, and/or control operations preceded by these symbols must be performed exclusively by qualified personnel*.
	Pay particular attention to the risk of moving parts
	Pay particular attention to components or systems under pressure.
	Pay particular attention to hot surfaces.
	Condensate drain point.
	Condensate drain point.
	Pay particular attention to the risk of electric shock.
	Rotation direction of the fan.
	Attention: Before performing any maintenance operation on this machine, do not forget to disconnect the electric supply, to completely discharge air pressure, and to refer to the Operators manual.

* Qualified personnel must be trained and certified in accordance with local laws and regulations.

■ GENERAL INFORMATION

■ FUNCTIONAL DESCRIPTION

Ingersoll Rand refrigerated air dryers remove moisture from compressed air. Moisture is detrimental to pneumatically operated appliances, controls, instruments, machinery and tools.



Compressed air enters the patented aluminum heat exchanger where it is cooled down to the dew point temperature in two different stages: In the first air/air sector compressed inlet air is cooled thanks to the colder compressed air coming out counterflow from the condensate separator. In the second refrigerant / air sector, compressed air temperature is further lowered to the dew point temperature. During this two stages almost all the oil and water vapours contained in compressed air are condensed to liquid and successively be separated from the compressed air in the condensate separator and drained out by the automatic drain. At this point the obtained cold air re-enters counterflow the initial air/air exchanger and it is reheated by the inlet hot air with the consequence of energy recovering and also reduction of the relative humidity contained in the outflowing air.

This dryer can be easily installed into various pneumatic systems in which dry air is required or desired. Refer to Principles of Operation for complete operating details.

The dryer comes provided with all the control, safety and adjustment devices, therefore no auxiliary devices are needed.

A system overload not exceeding the maximum operative limits can worsen the operational performance of the dryer (high dew point), but it will not affect its safety.





The electric diagram (attachment B) shows the minimum protection degree IP 42.

 	<p>Improper grounding can result in electrical shock and can cause severe injury or death.</p> <p>This product must be connected to a grounded, metallic, permanent wiring system or an equipment-grounding terminal or lead on the product.</p> <p>All grounding must be performed by a qualified electrician and comply with national and local electrical codes.</p> <p>In the event of an electrical short circuit, grounding reduces the risk of electric shock by providing an escape wire for the electric current.</p> <p>Ground must be established with a bare grounding wire sized according to the voltage and minimum branch circuit requirements.</p> <p>Ensure good bare metal contact at all grounding connection points, and ensure all connections are clean and tight.</p> <p>Check grounding connections after initial installation and periodically thereafter to ensure good contact and continuity has been maintained.</p> <p>Check with a qualified electrician or service technician if the grounding instructions are not completely understood, or if in doubt as to whether the product is properly grounded.</p>
--	--

■ USE OF THE MACHINE IN SAFE CONDITIONS

This system has been designed and manufactured in compliance with the European safety directive in force, therefore any installation, use and maintenance operations must be performed respecting the instructions contained in this manual.

Because an air dryer is pressurized and contains rotating parts, the same precautions should be observed as with any piece of machinery of this type where carelessness in operation or maintenance could be hazardous to personnel. In addition to obvious safety rules that should be followed with this type of machinery, safety precautions as listed below must be observed.

    	<ol style="list-style-type: none"> 1. Only qualified personnel shall be permitted to adjust, perform maintenance or repair this air dryer. 2. Read all instructions completely before operating unit. 3. Pull main electrical disconnect switch and disconnect any separate control lines, if used, before attempting to work or perform maintenance on the unit. 4. Do not attempt to service any part while machine is in an operational mode. 5. Do not attempt to remove any parts without first relieving the entire air system of pressure. 6. Do not attempt to remove any part of the refrigeration system without removing and containing refrigerant in accordance with the EPA and local regulations. 7. Do not operate the dryer at pressures in excess of its rating. 8. Do not operate the dryer without guards, shields and screen in place. 9. Inspect unit daily to observe and correct any unsafe operating conditions.
---	---

■ START UP

Switch on the main electrical isolation switch (if present). The control panel will show the message OFF, indicating that the line and control voltages are available.

Start sequence

The dryer will start closing the contact remote ON / OFF. The fan motor will start 30 seconds after the compressor.

Stop sequence

The dryer can be stopped locally from the control panel or opening the remote ON/OFF contact. After having pressed the ON/OFF switch for 1 second, the compressor and the fan motor keep on running for further 10 seconds in order to re-balance the internal pressures. The dryer can be also stopped due to an alarm or energy saving condition (ESA or ES2). Any alarm will de-energize the compressor, fan motor can still running, it depends on the type of alarm (see Display indications chapter). If the shutdown is due to an alarm, a message will blink on display indicating the reason for the shutdown. Energy saving condition (ESA or ES2) occurs when the dew point stands below the set value for a long time in order to save energy and avoid heat exchanger freezing. This situation can happen when ambient temperature is low and there is no compressed air load.

Variable speed fan control

A patented microprocessor allows to adjust dryer's cooling capacity by changing the fan motor speed. If the dew point is greater than the set value, the fan speed is increased, if the dew point is smaller than the set value, the fan velocity is decreased. The range can be from 0 to 100% and the higher is the fan speed, the faster the fan LED blinks, you can read the exact value by pressing the UP button.

If the velocity is 100% you will read FL (Full Load). Under load standard condition the fan speed is usually at 100%, if there is no load the fan velocity can oscillate between 0 and 20%.

■ CONTROL PANEL

The dryers are provided with an electronic control system. All adjustments and resets can be performed by means of the digital panel located on the front of the dryer. The control panel is composed of 5 keys (ON/OFF, TEST, SET, DOWN and UP) and a 3 digit display, with three signalling LED s indicated by icons (Figure 64).

Figure 64 : Display Visualization and Signalling LEDs

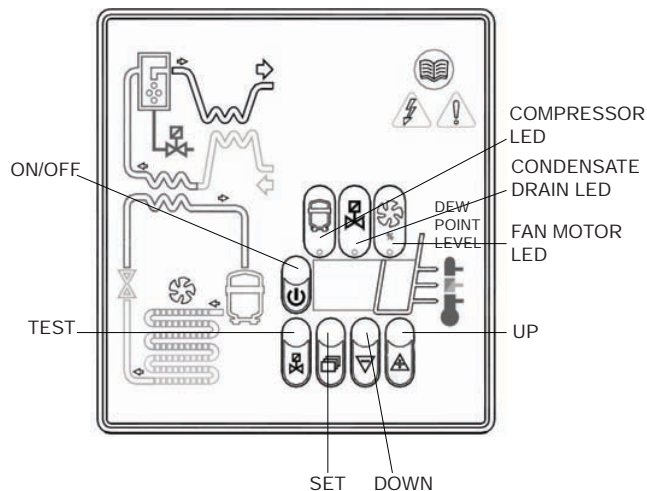

Table 24 : Display Icons

Display	Description
	the unit is ON with low load
	the unit is ON with normal load
	the unit is ON with normal-high load
	the unit is ON with high load

Table 25 : LED Display Icons

LED	Status	Description
	ON	Compressor energized
	Blinking	Programming mode activated
	ON	Condensate drain energized*
	Blinking	
	ON	Speed of the fan = 100%
	Blinking	Speed of the fan < 100%
	OFF	Fan not running

• Keys Function

TEST: When pushed for 3 sec. during normal operation, it activates the condensate drain.
(Not used on No loss condensate drain)

SET: When pushed and released during normal operation, it displays the parameter C1.
When pushed for 10 seconds, it allows to enter the C8 and C9 condensate drain parameters programming menu (see relevant table).
When pushed after having set new configuration values, it stores the applied modifications.

DOWN: When pushed while setting the drain set point, it decreases the displayed value of one unit per second, during the first 10 seconds, than of one unit every 0,1 sec.
When pushed for 10 seconds during normal operation, it starts an automatic test cycle of the controller.

UP: When pushed while setting the drain set point, it increases the displayed value of one unit per second, during the first 10 seconds, than of one unit every 0,1 sec.

ON / OFF: Pressed, it activates or deactivates the dryer. When the dryer is deactivated, the display shows OFF.

NOTE:

When the controller is in the OFF position, some parts of the dryer may still be energized. Therefore, for safety purposes, disconnect the electrical power before performing any operation on the machine.

• Condensate Discharge Parameters Programming



Push the SET key for 10 seconds to enter the parameters configuration menu: the display will show in sequence the set point value, the code of the first modifiable parameter (C8) and its value.

Only if strictly necessary, use the UP and/or DOWN keys to change the displayed parameter value.

Press the SET key to store the previously changed parameter value or to browse the parameters without changing them.

15 seconds after the last performed operation, the controller will return automatically to the normal operation mode.

Table 25

  	Parameter	Description	Range	Default Set Value
	C8	Delay between condensate discharges	1 ÷ 999 (min)	1
C9	Time required for condensate discharge	1 ÷ 999 (sec)	10	

NOTE

Changes entered for timing values will be effective only after exiting the programming, while changes to other variables will be immediately effective.

Remember that eventual changes to the configuration parameters of the machine could negatively affect its efficiency. Thus, changes have to be performed by a person familiar with the operation of the dryer.

WARNING

It's forbidden to attempt to modify the other configuration parameters of the electronic controller without authorization from Ingersoll Rand's authorized distributor.

• *Display Indications*

The controller is capable of recognizing certain types of anomalies in the drying circuit. In such cases, a message will blink on the display, alternated to the current dew point value.

Table 26: Display Indications

MESSAGE (BLINKING)	CAUSE	OUTPUTS	ACTIONS
HtA	High dew point value (delayed alarm)	Alarm output ON Refrig. Compressor output OFF	Resettable by switching off the dryer. If problem persists call your local Ingersoll Rand distributor.
Ht2	Very high dew point value (immediate alarm)	Fan output ON Drain cycle standard	
PF1	Interruption or short circuit on the PTC probe input line	Alarm output ON Refrig. Compressor output OFF Fan output OFF Drain cycle standard	Resettable by switching off the dryer. May require replacing the faulty probe. If problem persists call your local Ingersoll Rand distributor.
ESA	The automatic Energy saving mode activated due to low load	Alarm output OFF Refrig. Compressor output OFF Fan output OFF Drain cycle standard	No action necessary. Automatic Reset
ES2			
ASt	Activated after repeated alarms	Alarm output ON Refrig. Compressor output OFF Fan output ON Drain cycle standard	Call your local Ingersoll Rand distributor.

NOTE: PF1 has priority on all other messages.

• *Remote Signaling System*



The dryer control board is equipped with a dry contact for a remote alarm signal. This is normally open contact: when an alarm is detected, this contact is closed.

Proceed as follows to activate a remote alarm output:

1. The User must review the diagram below.
2. Disconnect the dryer from electrical power supply, remove cover and left side panel.
3. Connect the alarm circuit to the terminal blocks (See Figure 65).
4. Replace cover, left side panel and reconnect power.

Alarm Output electric features:

12V DC - 40mA on alarm,
0V on normal conditions.

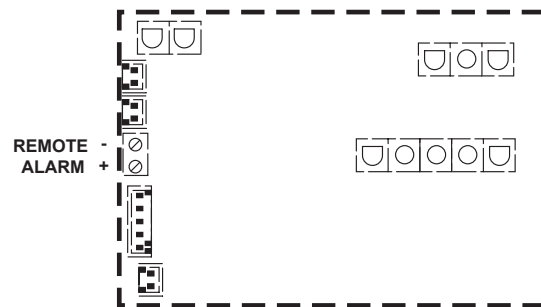

Figure 65

The activation of the above function is at the User's discretion. The User will purchase all necessary installation material. Any operation which needs access to the dryer must be carried out by qualified personnel.

■ BEFORE START UP



Before starting the machine, make sure that all operating parameters correspond to the nominal data.

The dryer is supplied already tested and preset for normal operation, and it doesn't require any calibration.



Nevertheless, it's necessary to check the operating performances during the first working hours.

■ START UP

The operations specified below must be performed after the first start up and at each start up after a prolonged inactive period of time due to maintenance operations, or any other reason.



1. Make sure that all instructions contained in chapters INSTALLATION SITE and INSTALLATION have been observed.

2. Ensure dryer by-pass is open and air inlet/outlet valves closed. (if existing).

3. Activate power supply and close the remote ON/OFF contact.



4. Wait 5 to 10 minutes until machine has achieved its standard operating parameters.

5. Slowly open the air outlet valve and successively open the air inlet valve.

6. If existent, close the air by-pass valve.

7. Check if the condensate drain is working properly.

8. Check if all connecting pipes are properly tightened and fixed.

Before disconnecting the dryer from electrical power supply, use ON/OFF button on controller to stop the dryer. Otherwise wait 10 minutes before switching the dryer on again, in order to allow freon pressure to rebalance.

NOTICES AND DISCLAIMERS

Machine models represented in this manual may be used in various locations worldwide. Machines sold and shipped into European community countries shall display the EC Mark and conform to various directives. In such cases, the design specification of this compressor has been certified as complying with EC directives. Any modification to any part is absolutely prohibited and would result in the CE certification and marking being rendered invalid.

The contents of this manual are considered to be proprietary and confidential to **Ingersoll Rand** and should not be reproduced without the prior written permission of **Ingersoll Rand**.

Nothing contained in this document is intended to extend any promise, warranty or representation, expressed or implied, regarding the **Ingersoll Rand** products described herein. Any such warranties or other terms and conditions of sale of products shall be in accordance with the standard terms and conditions of sale for such products, which are available upon request.

Ingersoll Rand reserves the right to make changes and improvements to products without notice and without incurring any obligation to make such changes or add such improvements to products sold previously.

Details of approved equipment are available from **Ingersoll Rand** Service departments.

The company accepts no responsibility for errors in translation of this manual from the original English version.

The design of this Compressor package and certain features within it are covered by patents held by Ingersoll Rand and patents pending.

WARRANTY

The Company warrants that the equipment manufactured by it and delivered hereunder will be free of defects in material and workmanship for a period of twelve months from the date of placing the Equipment in operation or eighteen months from the date of shipment from the factory, whichever shall first occur. The Purchaser shall be obligated to promptly report any failure to conform to this warranty, in writing to the Company in said period, whereupon the Company shall, at its option, correct such nonconformity, by suitable repair to such equipment or, furnish a replacement part F.O.B. point of shipment, provided the Purchaser has stored, installed, maintained and operated such Equipment in accordance with good industry practices and has complied with specific recommendations of the Company. Accessories or equipment furnished by the Company, but manufactured by others, shall carry whatever warranty the manufacturers have conveyed to the Company and which can be passed on to the Purchaser. The Company shall not be liable for any repairs, replacements, or adjustments to the Equipment or any costs of labor performed by the Purchaser or others without Company's prior written approval.

The effects of corrosion, erosion and normal wear and tear are specifically excluded. Performance warranties are limited to those specifically stated within the Company's proposal. Unless responsibility for meeting such performance warranties are limited to specified tests, the Company's obligation shall be to correct in the manner and for the period of time provided above.

THE COMPANY MAKES NO OTHER WARRANTY OR REPRESENTATION OF ANY KIND WHATSOEVER, EXPRESSED OR IMPLIED, EXCEPT THAT OF TITLE, AND ALL IMPLIED WARRANTIES OF MERCHANTABILITY AND FITNESS FOR A PARTICULAR PURPOSE, ARE HEREBY DISCLAIMED.

Correction by the Company of nonconformities whether patent or latent, in the manner and for the period of time provided above, shall constitute fulfillment of all liabilities of the Company for such non conformities whether based on contract, warranty negligence, indemnity, strict liability or otherwise with respect to or arising out of such Equipment.

The purchaser shall not operate Equipment which is considered to be defective, without first notifying the Company in writing of its intention to do so. Any such use of Equipment will be at Purchaser's sole risk and liability.

Note that this is **Ingersoll Rand** standard warranty. Any warranty in force at the time of purchase of the compressor or negotiated as part of the purchase order may take precedence over this warranty.



A series of horizontal lines spanning the width of the page, providing a template for writing.



A series of horizontal lines forming a ruled page for writing.

