



# SPARE PARTS LIST

CHAIN SAWS

T536LiXP

**D2** T536 LiXP  
ELECTRIC, CONTROL UNIT GEN 2

UP TO S/N 20180600615

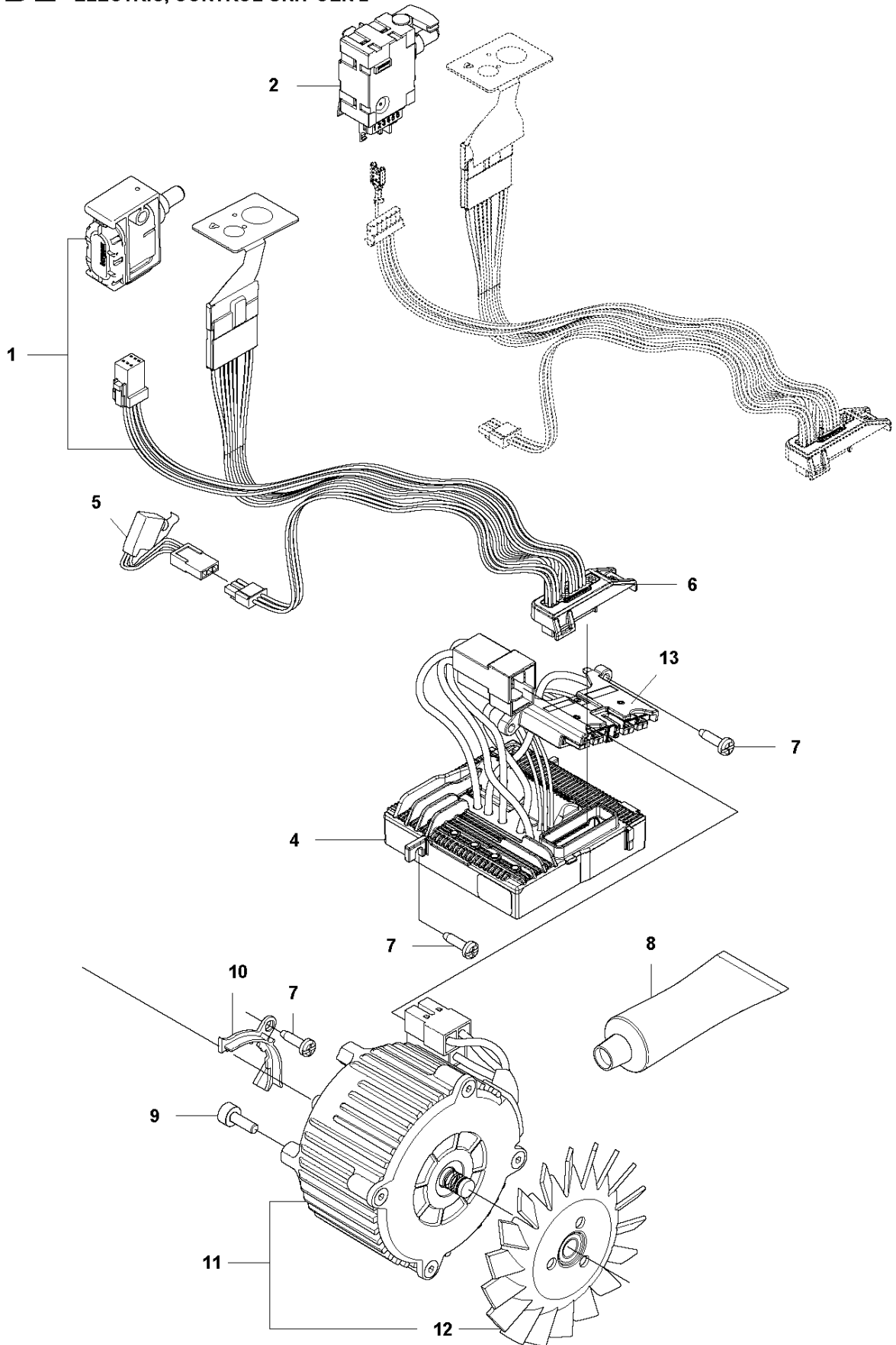

## ELECTRICAL

T536LiXP

Ref	Part No	Description	Remark	QTY KIT
1	593 89 61-01	SWITCH KIT		1
2	578 32 69-01	TRIGGER SWITCH		1
4	586 26 52-01	CONTROL UNIT		1
5	577 82 77-01	WIRING ASSY		1
6	587 32 72-01	BRACKET		1
7	503 21 28-13	SCREW CCRPANT		5
9	503 20 25-12	SCREW IHSCM		1
8	588 17 64-01	GREASE	For application instruction, see SB-1500022	1
10	577 58 52-01	COVER		1
11	577 31 58-02	MOTOR ASSY	Complete with fan	1
12	581 30 09-01	FAN		1
13	593 81 30-01	CONNECTOR		1

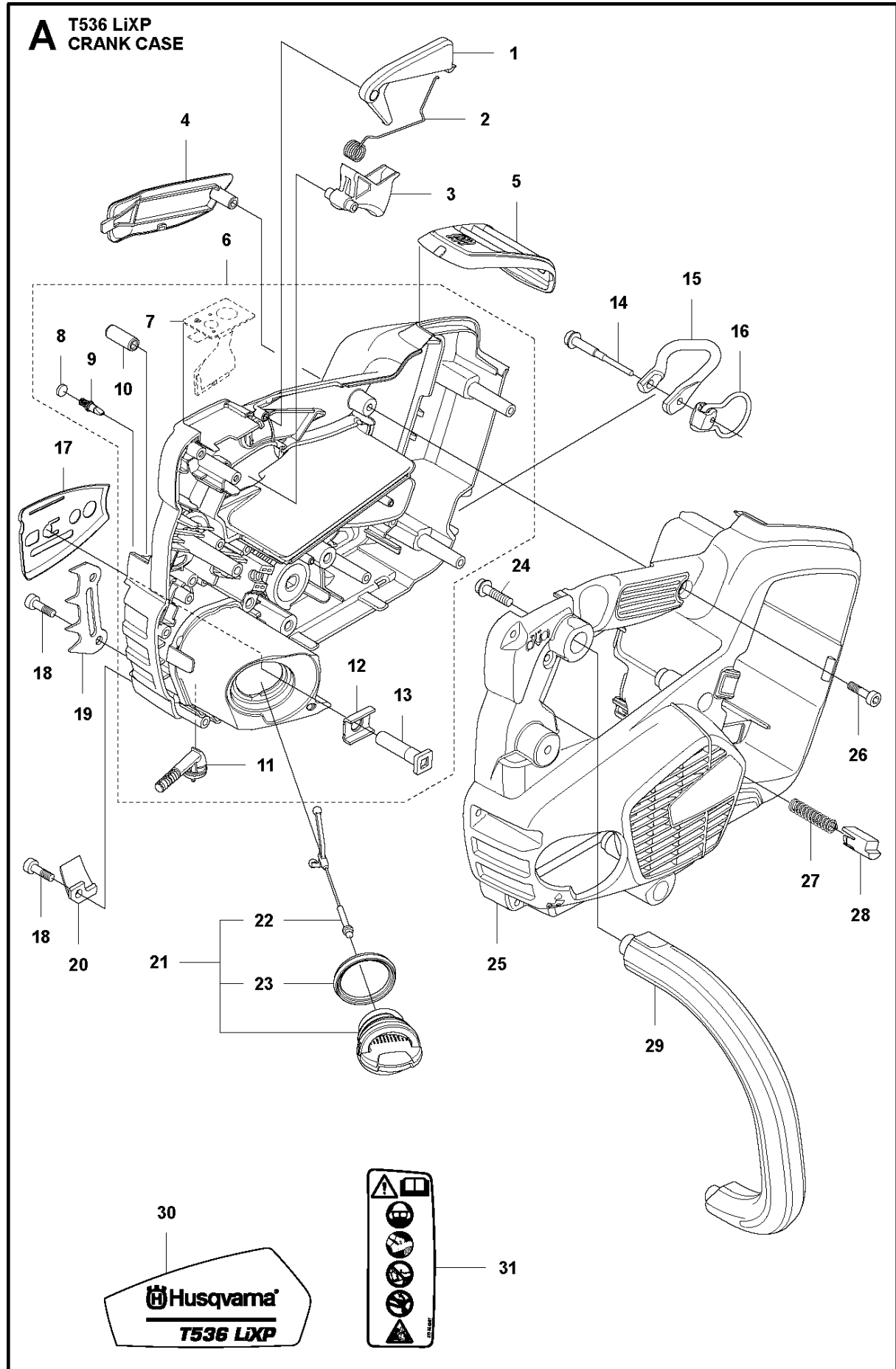

## CRANKCASE

T536LiXP

Ref	Part No	Description	Remark	QTY	KIT
1	506 49 57-01	THROTTLE LOCKOUT		1	
2	544 09 99-01	SPRING		1	
3	577 31 26-01	THROTTLE CONTROL		1	
4	576 90 09-01	HANDLE INSERT		1	
5	576 90 12-01	COVER		1	
6	581 69 09-01	CRANKCASE ASSY		1	
7	581 69 05-01	KEYPAD		1	6
8	537 40 35-01	FILTER		1	6
9	530 02 61-19	CHECK VALVE		1	6
10	501 62 33-01	SPRING PIN		1	6
11	581 12 02-01	OIL SCREEN		1	6
12	576 99 97-01	STIFFENING PLATE		1	6
13	503 87 54-01	BAR BOLT		1	6
14	522 84 79-01	SCREW ITXSCFM		1	
15	576 38 13-01	LOOP		1	
16	580 86 00-01	LOOP		1	
17	576 90 14-01	CHAIN GUIDE		1	
18	503 21 74-16	SCREW IHST		3	
19	577 28 66-01	INDRE BARKSTØD		1	
20	505 28 85-01	CHAIN CATCHER		1	
21	522 62 00-01	TANK CAP ASSY		1	
22	503 57 89-01	HOLDER		1	21
23	537 21 50-01	SEALING		1	21
24	503 21 68-72	SCREW IHST		2	
25	576 90 10-02	CRANKCASE		1	
26	503 21 66-74	SCREW IHST		9	
27	585 48 00-01	SPRING		1	
28	577 99 66-01	PUSH BUTTON		1	
29	576 90 11-01	FRONT HANDLE		1	
30	578 22 90-01	DECAL		1	
31	577 84 43-01	DECAL		1	

**B** T536 LiXP  
CLUTCH

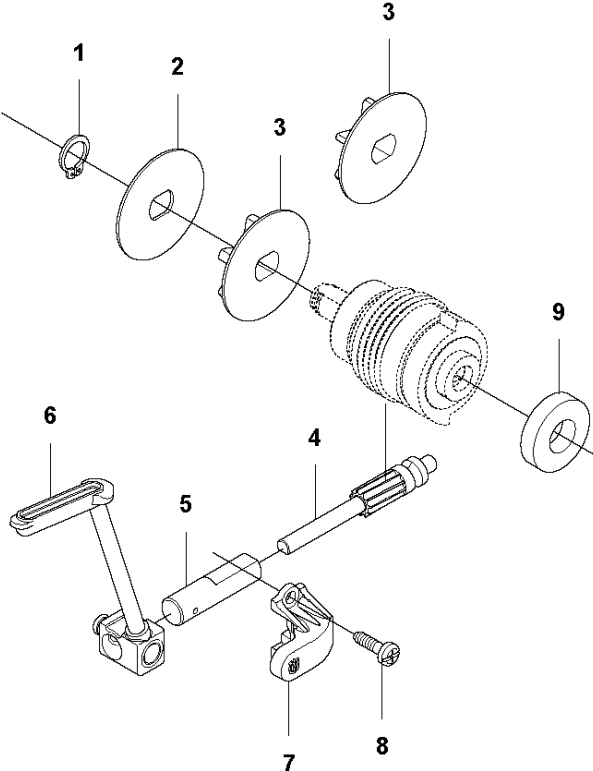

## CLUTCH

T536LiXP

Ref	Part No	Description	Remark	QTY KIT
1	735 31 12-00	CIRCLIP		1
2	577 27 15-01	WASHER		1
3	577 60 76-01	SPUR SPROCKET	"3/8"" - 6T"	1
3	579 53 45-01	SPUR SPROCKET	"1/4"" - 8T"	1
4	540 05 79-01	PUMP PISTON		1
5	537 15 48-01	PUMP CYLINDER		1
6	577 27 25-01	OIL HOSE		1
7	579 24 69-01	BRACKET		1
8	503 21 28-13	SCREW CCRPANT		2
9	580 76 06-01	DISTANCE		1





## CHAIN BRAKE

T536LiXP

Ref	Part No	Description	Remark	QTY	KIT
1	576 90 56-01	CLUTCH COVER ASSY		1	
2	576 90 57-01	CLUTCH COVER		1	1
3	505 19 73-01	NUT		1	1
4	577 72 21-01	CHIP GUARD		1	1
5	503 21 70-72	SCREW CCRPANT		3	1
6	501 45 41-02	NUT		1	1
7	537 39 70-01	WORM SCREW		1	1
8	740 48 07-02	O-RING		1	1
9	503 23 00-63	WASHER		1	1
10	537 07 94-02	WORM WHEEL		1	1
11	505 21 45-01	COVER LID		1	1
12	576 90 38-01	HAND GUARD		1	
13	503 89 30-01	SCREW		2	
14	577 64 98-01	TORSION SPRING		1	
15	577 54 95-01	SHAFT ASSY		1	
16	577 27 20-01	CATCH		1	
17	576 90 46-01	SPRING		1	
18	577 36 56-01	BRACKET		1	
19	503 21 28-13	SCREW CCRPANT		3	
20	578 22 89-01	DECAL		1	1

**D1** T536 LiXP  
ELECTRIC, CONTROL UNIT GEN 1

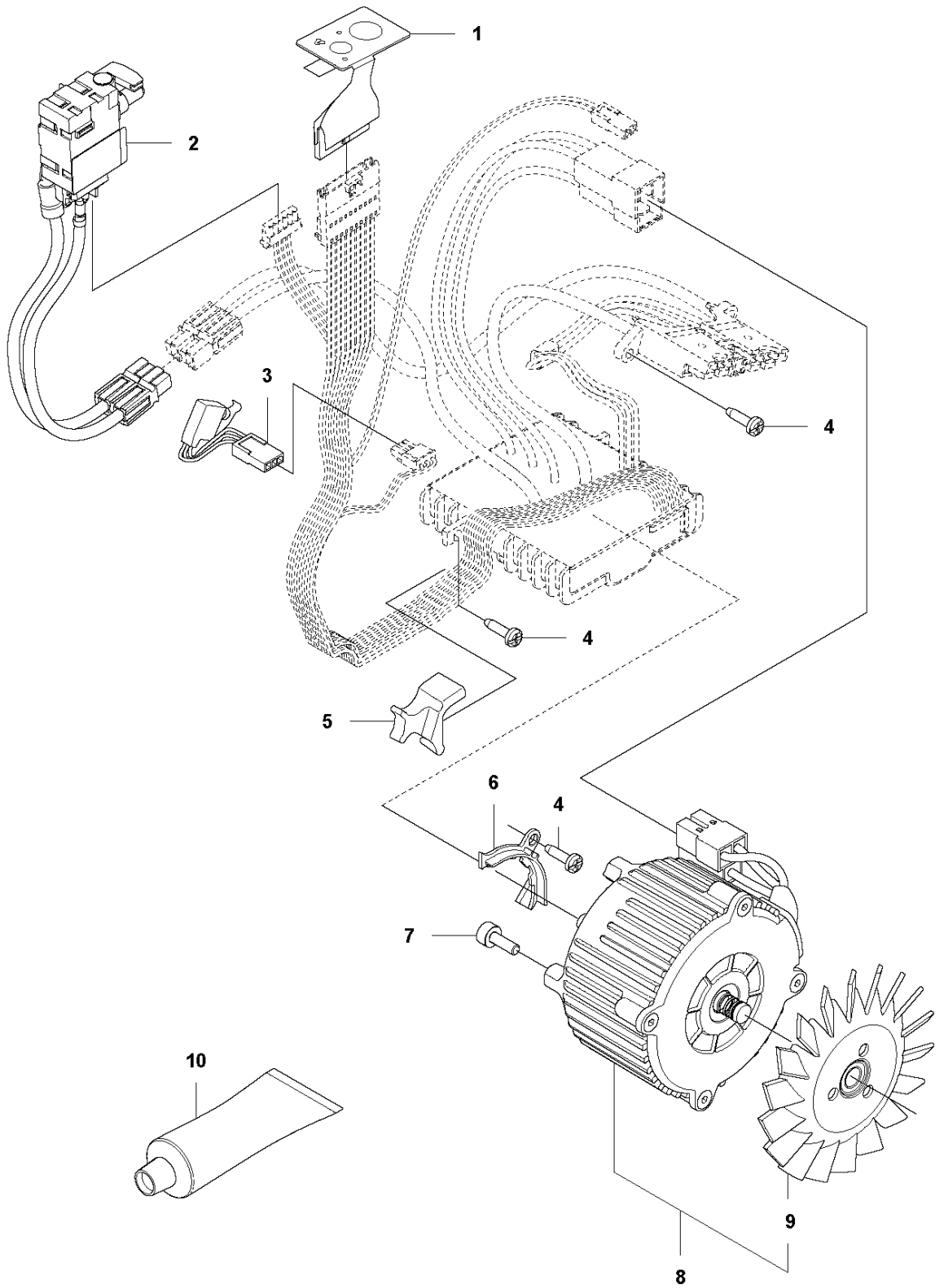

ELECTRICAL

T536LiXP

Ref	Part No	Description	Remark	QTY KIT
1	585 85 53-01	KEYPAD		1
2	577 03 33-01	WIRING ASSY		1
3	577 82 77-01	WIRING ASSY		1
4	503 21 28-13	SCREW CCRPANT		5
5	579 59 79-01	BRACKET		1
6	577 58 52-01	COVER		1
7	503 20 25-12	SCREW IHSCM		1
8	577 31 58-02	MOTOR ASSY	Complete with fan	4
9	581 30 09-01	FAN		1
10	588 17 64-01	GREASE	For application instruction, see SB-1500022	1

**E** T536 LiXP  
ACCESSORIES

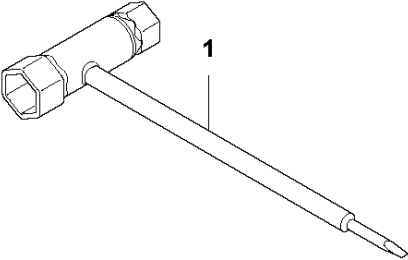

2

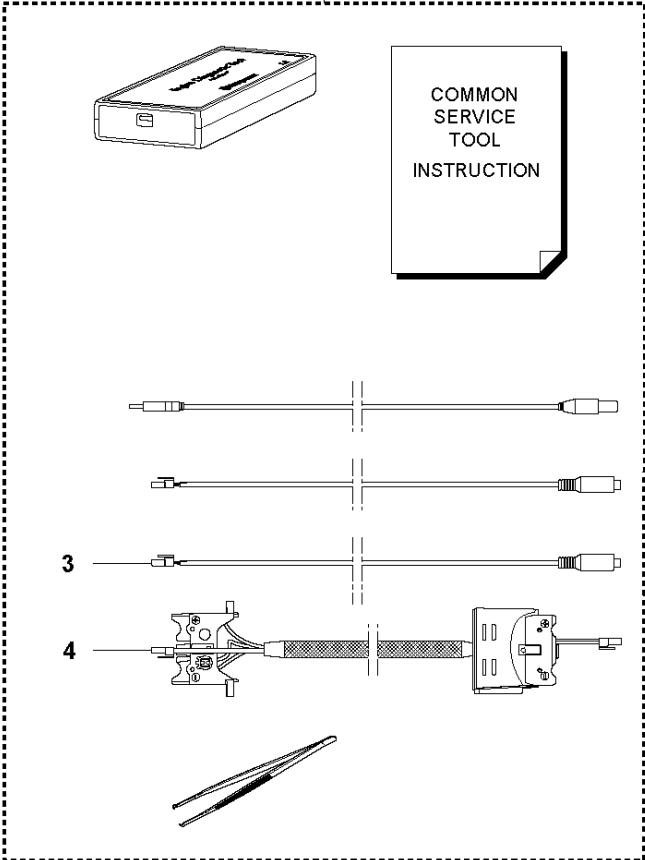

## ACCESSORIES

T536LiXP

Ref	Part No	Description	Remark	QTY	KIT
1	501 69 17-01	COMBINATION WRENCH		1	
2	583 89 71-01	DIAGNOSTIC TOOL KIT		1	
3	576 95 22-01	CABLE ASSY		1	2
4	579 62 13-01	WIRING ASSY		1	2

**D3** T536 LiXP  
ELECTRIC, CONTROL UNIT GEN 2

FROM S/N 20180600615 -

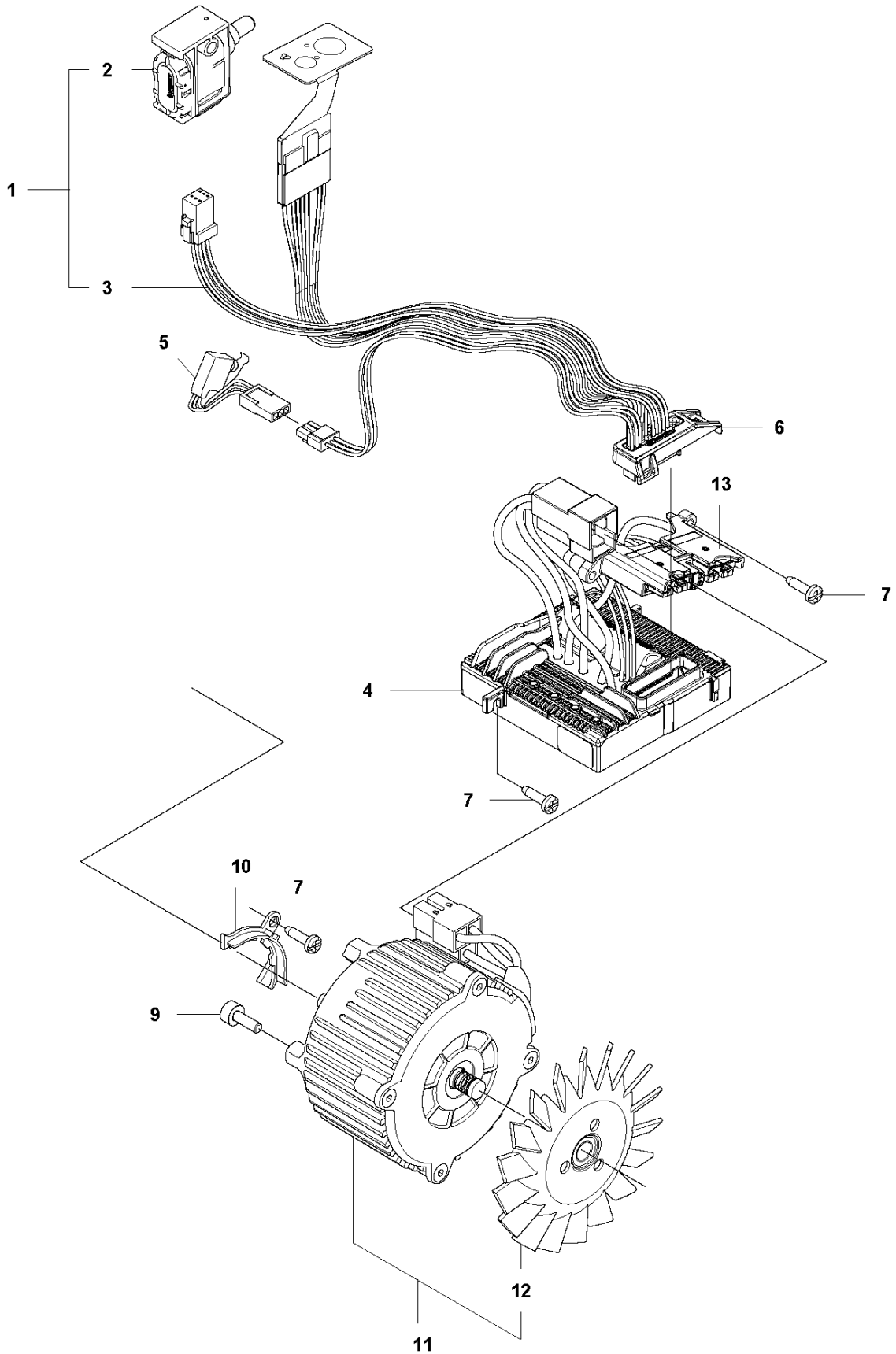

## ELECTRICAL

T536LiXP

Ref	Part No	Description	Remark	QTY	KIT
1	593 89 61-01	SWITCH KIT		1	
2	582 05 07-01	TRIGGER SWITCH		1	1
3	582 71 34-01	WIRING ASSY		1	1
4	586 26 52-01	CONTROL UNIT	Replacing 578 37 07-01. For application, see SB-1500022	1	
5	577 82 77-01	WIRING ASSY		1	
6	587 32 72-01	BRACKET		1	
7	503 21 28-13	SCREW CCRPANT		5	
9	503 20 25-12	SCREW IHSCM		1	
10	577 58 52-01	COVER		1	
11	577 31 58-02	MOTOR ASSY	Complete with fan	1	
12	581 30 09-01	FAN		1	
13	593 81 30-01	CONNECTOR		1	