

# HURRICANE CONCRETE PAD FOR GENERAC GENERATORS (GENERAC UNITS)

**LIMITS & REQUIREMENTS OF USE:**

- 1) THE PAD AND THE SUPPORTED EQUIPMENT MUST BE LOCATED AT GROUND LEVEL. THIS TABLE DOES NOT APPLY TO ROOFTOP EQUIPMENT, EQUIPMENT LOCATED ON BALCONIES, OR ANY OTHER EQUIPMENT TO BE ELEVATED ABOVE GROUND LEVEL.
- 2) THE AREA UNDER CONCRETE SLAB ON GROUND SHALL HAVE ALL MATERIALS REMOVED PRIOR TO INSTALLATION ON COMPACTED SOIL AS VERIFIED BY OTHERS. MINIMUM SOIL COEFFICIENT OF FRICTION = 0.25
- 3) MAXIMUM DIMENSIONS AND WEIGHT OF GENERATORS UNIT SHALL CONFORM TO SPECIFICATIONS STATED HEREIN. PAD WEIGHT TO BE VERIFIED BY OTHERS.
- 4) ORIGINAL EQUIPMENT MANUFACTURER INSTALLATION INSTRUCTIONS SUPERSEDE HURRICANE PAD INSTALLATION INSTRUCTIONS IF MORE STRINGENT.
- 5) ELECTRICAL GROUND, WHEN REQUIRED, TO BE DESIGNED & INSTALLED BY OTHERS. ALL MECHANICAL SPECIFICATIONS (CLEAR SPACE, TONNAGE, ETC.) SHALL BE AS PER MANUFACTURER RECOMMENDATIONS AND ARE THE EXPRESS RESPONSIBILITY OF THE CONTRACTOR.
- 6) ENGINEER SEAL AFFIXED HERETO VALIDATES STRUCTURAL DESIGN AS SHOWN ONLY. USE OF THIS SPECIFICATION BY CONTRACTOR, et. al. INDEMNIFIES & SAVES HARMLESS THIS ENGINEER FOR ALL COST & DAMAGES INCLUDING LEGAL FEES & APPELLATE FEES RESULTING FROM MATERIAL FABRICATION, SYSTEM ERECTION, CONSTRUCTION PRACTICES BEYOND THAT WHICH IS CALLED FOR BY LOCAL, STATE, & FEDERAL CODES & FROM DEVIATIONS OF THIS PLAN.
- 7) THE ROLE OF THIS ENGINEER FOR THIS PROJECT IS THAT OF SPECIALTY ENGINEER AND NOT THE ENGINEER OF RECORD. CONSEQUENTLY, THE ARCHITECT/ENGINEER OF RECORD SHALL BE RESPONSIBLE FOR THE INTEGRITY OF ALL SUPPORTING SURFACES TO THIS DESIGN WHICH SHALL BE COORDINATED BY THE PERMITTING CONTRACTOR.
- 8) THIS DOCUMENT IS GENERIC AND DOES NOT PERTAIN TO ANY SPECIFIC PROJECT SITE.
- 9) THIS ENGINEER SHALL NOT BE HELD RESPONSIBLE OR LIABLE IN ANY WAY FOR ERRONEOUS OR INACCURATE DATA OR MEASUREMENTS. DIMENSIONS ARE SHOWN TO ILLUSTRATE DESIGN FORCES AND OTHER DESIGN CRITERIA. THEY MAY VARY SLIGHTLY, BUT MUST REMAIN WITHIN THE LIMITATIONS SPECIFIED HEREIN.
- 10) THIS ENGINEER SHALL BE NOTIFIED AND GIVEN AN OPPORTUNITY TO RE-EVALUATE THIS WORK UPON DISCOVERY OF ANY INACCURATE INFORMATION PRIOR TO MODIFICATION OF EXISTING FIELD CONDITIONS AND FABRICATION AND INSTALLATION OF MATERIALS.
- 11) ALTERATIONS OR ADDITIONS TO THIS DOCUMENT ARE NOT PERMITTED AND INVALIDATE THIS CERTIFICATION.
- 12) EXCEPT AS EXPRESSLY PROVIDED HEREIN, NO ADDITIONAL CERTIFICATIONS OR AFFIRMATIONS ARE INTENDED.
- 13) PADS SHALL BE CONSTRUCTED WITH PRECAST CONCRETE, MINIMUM COMPRESSIVE STRENGTH,  $f_c = 7,000$  PSI AT 28 DAYS.
- 14) ALL OTHER UNITS NOT SHOWN SHALL BE DESIGNED ON A CASE BY CASE BASIS.
- 15) CONTRACTOR SHALL PROVIDE 5/8" DIA. (0.675" O.D.) GALV. TUBE ASTM A53B SCH 40 MIN. OR 1/2" DIA. SOLID COPPER BAR SPIKE 4' MIN. EMBED. (SEE MIN. EMBED. AS PER CURRENT ELECTRICAL CODE, BY OTHERS) INTO GROUND THROUGH CONCRETE PAD FOR SLIDING RESISTANCE PURPOSE, 12 DIAMETERS EDGE DISTANCE FROM ANY CONCRETE FACE (NOT SHOWN).
- 16) PADS / UNITS INSTALLED DIRECTLY ON ANY COASTLINE REQUIRE A HEAVIER AND LARGER PAD TO ACCOUNT FOR EXPOSURE D ; Table 28.3-1;  $K_z = 1.03$

**ENGINEERING DATA:**

- 1) ANALYSES PER 6th EDITION (2017) FLORIDA BUILDING CODE - SECTION 1620 HIGH VELOCITY HURRICANE ZONES.
- 2) WIND LOADS & LOAD COMBINATIONS PER ASCE 7-10 SECTION 2.4.1 (LOAD COMBINATIONS), SECTION 29.5 & FIGURE 29.5.1 FOR: WIND LOADS ON OTHER STRUCTURES
- 3) RISK CATEGORY = II TABLE 1604.5 - RISK CATEGORY OF BUILDINGS AND OTHER STRUCTURES, SECTION 301.15 OF THE MECHANICAL CODE, WIND RESISTANCE, AND 553.844 OF THE FLORIDA STATUTES WIND STORM LOSS MITIGATION.
- 4) WIND LOAD:

Wind Speed V =	<b>185</b>	MPH (RISK CATEGORY II)
$F = qz * G * Cf * Af$ (Eq. 29.5-2) =	74.63	*Af (lbs)
$qz = 0.00256 * Kz * Kzt * Kd * V^2$ =	67.03	PSF

Exposure C ; Table 28.3-1  $K_z = 0.85$

Figure 26.8-1	Kzt =	1.00
Table 26.6-1	Kd =	0.90
Figure 29.5-1	Cf =	1.31
	G =	0.85

DiversiTech Corporation  
6650 Sugarloaf Parkway #100  
Duluth, GA 30097  
(800) 397-4823

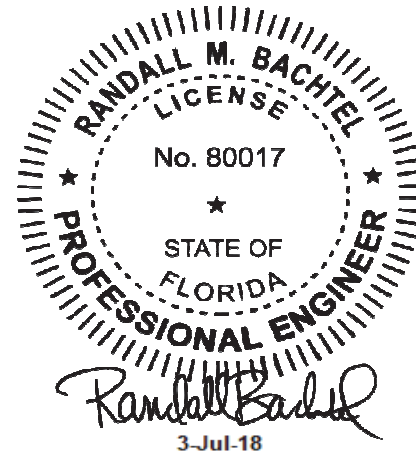

**RMB ENGINEERING LLC**  
Solving Problems to Minimize the Stress of Doing Business

Randall M. Bachtel, P.E. - 770.713.0823 / 770.713.6464

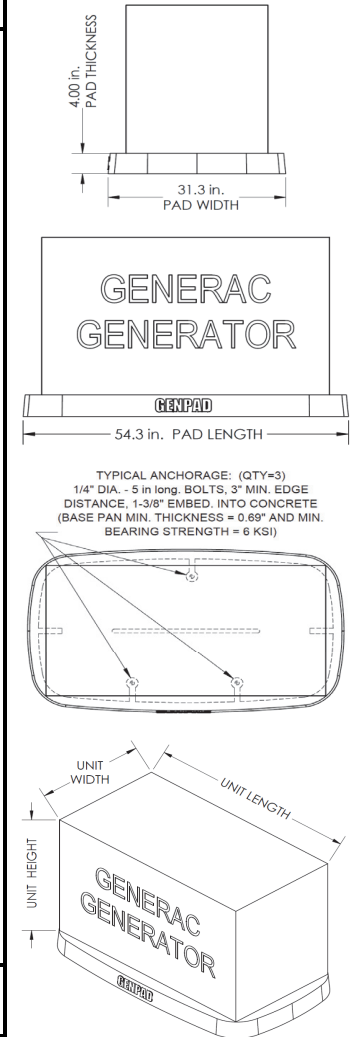

AIR COOLED PAGE 1 of 1	UNIT / EQUIPMENT			FG8341-4G PAD USED FOR ALL						185 MPH		0.6(UNIT+ PAD) RESISTING WEIGHT MOMENT FT-LBS.	DESIGN CHECK			
	MAXIMUM DIMENSIONS INCHES			MINIMUM WEIGHT LBS.	MODEL NUMBER	(2pc PAD) WEIGHT LBS.	PAD WIDTH IN.	2pc PAD LENGTH IN.	PAD THICK IN.	WIND LOAD LBS.	0.6(WIND MOMENT) FT-LBS.					
	WIDTH	LENGTH	HEIGHT													
GENERAC 09kW	25	48	29	340	FG5431-4G	275	31.3	54.3	4	721	667	369.0	481	OK FOR	0	MPH
GENERAC 11kW	25	48	29	348	FG5431-4G	275	31.3	54.3	4	721	667	373.8	487	OK FOR	0	MPH
GENERAC 16kW	25	48	29	406	FG5431-4G	275	31.3	54.3	4	721	667	408.6	533	OK FOR	0	MPH
GENERAC 20kW	25	48	29	448	FG5431-4G	275	31.3	54.3	4	721	667	433.8	566	OK FOR	0	MPH
GENERAC 22kW	25	48	29	466	FG5431-4G	275	31.3	54.3	4	721	667	444.6	580	OK FOR	0	MPH