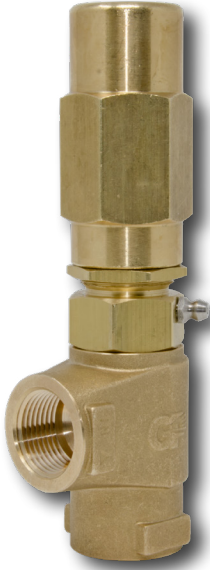

GENERAL PUMP *A member of the Interpump Group*

CWR1003/CWR4525

Regulating Valve**FEATURES**

- Grease zerk keeps piston and seal lubricated
- Ideal for use in rollover car washes
- Sturdy brass construction
- Multiple connections for easy installation
- Works with General Pump's Emperor HTCK pumps
- Protects against pressure spikes
- Regulates variations in pressure
- Patent Pending
- Made in the USA

General Pump recommends using a safety relief device in conjunction with this regulating valve when installed on a positive displacement pump. General Pump is not liable and assumes no responsibility when used in a customer's high pressure system.

SPECIFICATIONS

Part Number:		CWR1003	CWR4525
Max Flow		10.0 GPM	45.0 GPM
Rated Pressure		300 PSI	2,500 PSI
Max Temperature		195° F	
Port Size	Inlet:	3/4" NPT-F	
	Outlet:	1/2" NPT-F	
Dimensions		6.6" (nom) x 1.6"	
Weight		2.0 lbs	
Material:		Brass	

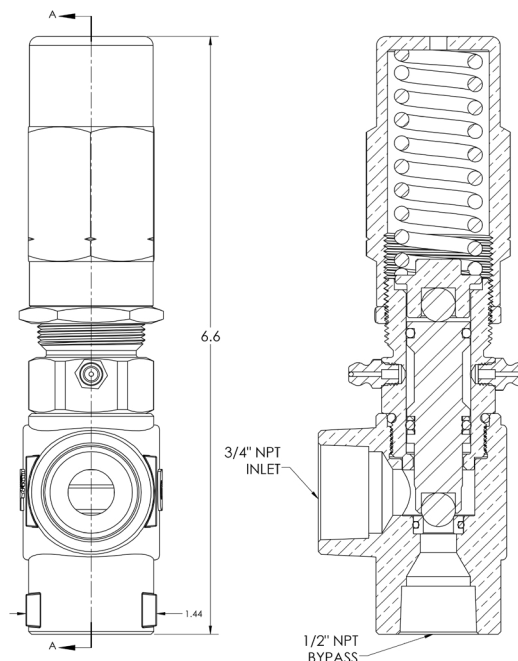
DIMENSIONS

General Pump
is a member of
the Interpump Group



Ref 310116 Rev. H
02-20



PARTS LIST

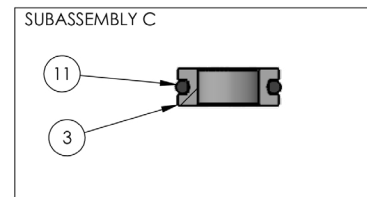
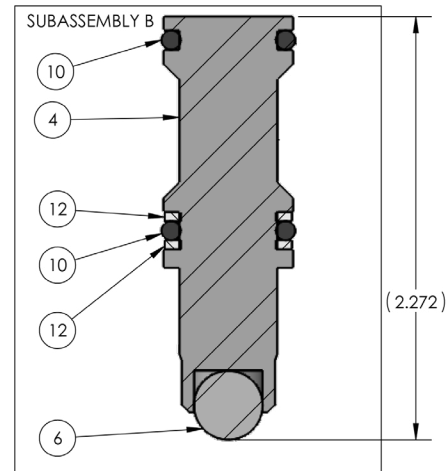
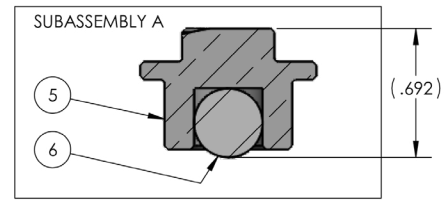
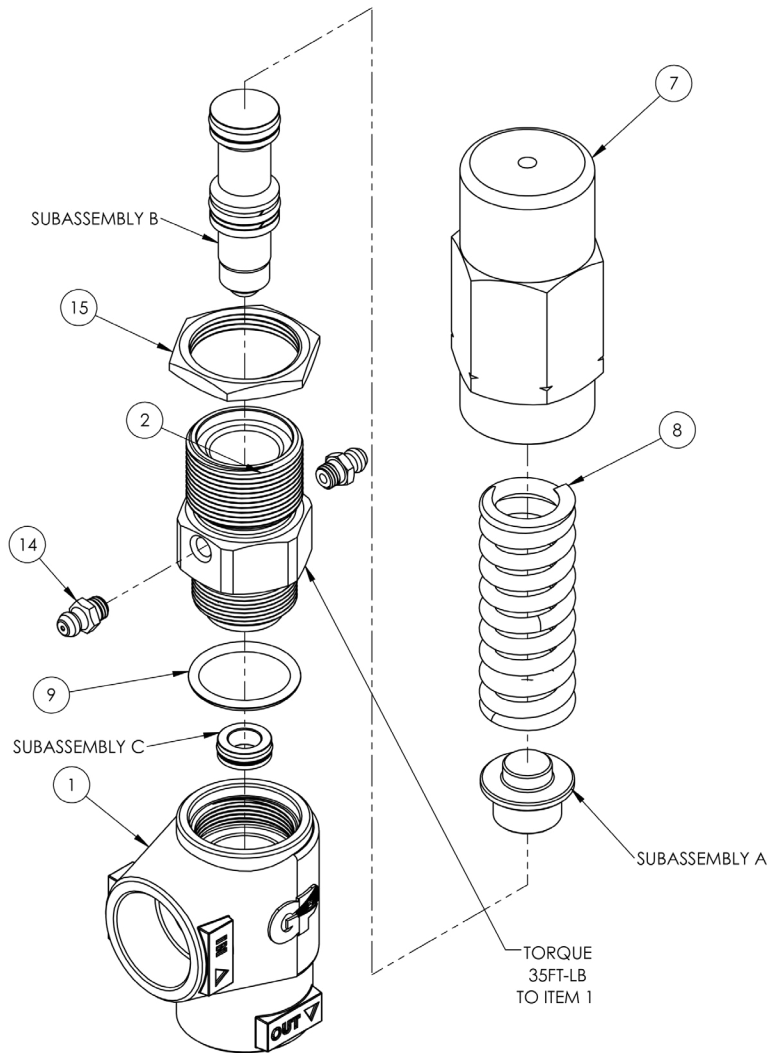

ITEM	PART #	DESCRIPTION	QTY
1	510490	Body	1
2	510491	Piston housing	1
3*	520418	Seat	1
4*	520422	Piston	1
5	510495	Spring plate	1
6*	520421	Ball, 3/8"	2
7	510492	Cap	1
8	720073	Spring, 2.6 x 1.05 (CWR4525)	1
	720071	Spring, 2.5 x .97 (CWR1003)	1
9*	701135	O-ring, .924 ID s .103 CS	1
10*	701136	O-ring, 13.1 mm x 2.62	2
11*	701137	O-ring, .426 ID x .070 CS	1
12*	660269	Back-up ring	2
14**	640092	Grease Zerk	2
15	510496	Nut, Locking, M30 x 1.5	1
*	K316	Repair Kit	

100256 Mini Grease Gun Kit

- 3oz Mini Grease Gun Kit: (GP # 100256) (1 Cartridge incl.)
- 3oz Mini cartridge: (GP #100264)

640015 Regular Grease Gun

- 14oz Regular Grease Gun: (GP # 640015) (Cartridge not incl.)
- 14oz Regular cartridge: (GP #800054)

**** USE SILICON GREASE ONLY**



WARNING: This product can expose you to chemicals, including lead, which is known to the state of California to cause cancer and birth defects or other reproductive harm. For more information, go to www.P65Warnings.ca.gov

THIS DOCUMENT PROVIDES THE INSTRUCTIONS FOR THE INSTALLATION, USE AND MAINTENANCE OF THE VALVE, THEREFORE IT IS AN INTERNAL PART OF THE VALVE ITSELF AND MUST BE READ CAREFULLY BEFORE ANY USE AND KEPT WITH CARE.

STRICTLY COMPLY WITH THE INSTRUCTIONS CONTAINED IN THIS DOCUMENT IN VIEW OF A SAFE AND EFFECTIVE USE OF THE VALVE.

FAILURE TO COMPLY WITH THESE INSTRUCTIONS MIGHT CAUSE EARLY FAULTY AND RESULTS IN SITUATIONS OF DANGER, IN ADDITION TO VOIDING ANY WARRANTY.

1. GENERAL INFORMATION

1.1 The CWR pressure regulator is a manually adjustable pressure-operated device which, according to its setting releases the excess of water when the pressure inside the pump/system exceeds the adjusted value, thus reducing the pressure. When the outlet flow is impeded on, this device totally releases the flow - and keeps under pressure the portion of the system preceding the valve.

1.2 Since the CWR valve is used in connection with a high pressure water pump/system, which shall be called hereafter only "system", installation and use must be suited to the type of system used and comply with the safety regulations in force in the country where the valve is used.

1.3 Before using the valve, make sure the system the valve is used with is certified to comply with the relevant directives and/or regulations.

1.4 Before installing and using the valve for the first time, we suggest you check that it is undamaged and make sure that the rated features correspond to the required ones. If this is not the case, do not use the valve and contact General Pump Customer Service.

1.5 In order to install the valve correctly, follow the instructions for the water inlet, outlet and by-pass connections, as stated in this instruction manual and or on the valve itself.

2. PACKAGE

2.1 Packages must be handled in compliance with the instructions stated on the packages themselves and/or provided by the manufacturer.

2.2 In case the valve is not used immediately, it must be stored in its integral package and placed in areas which are not exposed to the weather and protected from excessive humidity and from direct sunlight. Moreover, it is advisable to place wooden pallets or other typed of pallets between the package and the floor, in order to prevent the direct contact with the ground.

2.3 The package components must be disposed of in compliance with the relative laws in force.

3 INSTRUCTION FOR INSTALLATION AND PRESSURE SETTING

3.1 In order to obtain a correct adjustment and consequently a proper functioning valve, always make sure that, when working at the maximum pressure, the valve by-pass keeps releasing a quantity of water equal to 5% of the total flow rate. If the flow rate at the by-pass is close to zero or exceeds the maximum flow rate, this could cause faults, early wear and/or a dangerous situation.

The positions mentioned in the following instructions refer to those shown in the exploded view.

3.2 Connect the valve to the water system and follow these steps:

3.2.1 Unloose the adjustment cap pos. 7 in order to completely release the spring.

3.2.2 Open the gun or the water control device and start the system. Make sure that the air contained in the system is fully removed.

3.2.3 Keeping the gun or water control device open, increase the pressure by screwing down the cap pos. 7. Alternate the adjusting operations with a few openings and closing of the gun or of the control device.

3.2.4 When the desired pressure has been reached, open and close the gun/control device a few times again in order to stabilize the various components (seals, springs, etc.).

3.2.5 Fix the knob position by screwing the nut pos. 15.



In case of doubts, do not hesitate to contact General Pump Customer Service. IMPORTANT: During use, never exceed the maximum values of pressure, flow rate and temperature as stated in this document and/or on the valve.



General Pump disclaims all responsibility for any damages cause by the inaccurate adjustment of the setting pressure an/or by any incorrect use of the valve that cannot be reasonably predicted.

4 WARNINGS

4.1 The installation and the variation of the working pressure must be made by qualified personnel, who must have the required skills to handle high pressure systems and be informed of the operating and safety instructions contained in this document.

4.2 The installer must provide the ultimate consumer with the proper instructions for the correct use of the system the valve will be used in connection with.

4.3 Use soft and filtered water only. In case of salt water and/or of water containing solid particles of a size exceeding 360 µm, the internal components of the valve will be subject to quick wear; furthermore this might compromise the correct functioning of the valve.



4.4 In the systems for hot water productions the temperature of the liquid that comes into contact with the valve must always be lower than the value stated in this instruction manual and indicated on the valve itself. **Avoid the formation of steam or over heated water.**



IMPORTANT: When the temperature of the liquid is close to the maximum value, the outside temperature of the valve body may become hot. Take care in case of contact with the hot surfaces.

4.5 After use and/or before performing any operation on the system or on the valve, release the pressure by opening the gun or control device for a few seconds. The jet created by the residual pressure must be directed downwards in order to avoid damages or dangers.

4.6 For safety reasons, it is advisable to equip the high pressure feeding line of the system also with a relief or safety valve duly adjusted.

4.7 To connect the valve to the system it is preferable to use flexible hoses fitted in a way that they do not form 90° elbows, throttlings or siphons which could include air bubbles. The inside diameters of the hoses and fittings must be equal to the correspondent inside diameters of the inlet, by-pass and outlet threads of the valve. Moreover, it is necessary to correctly choose the type of hose depending on the rated pressure and flow-rate; the hoses must be used within their operation limits as stated by the manufacture and indicated on the hoses themselves.

4.8 Connect the fittings to the valve and tighten. If necessary, a proper sealant can be used in order to ensure the thread.

4.10 Before operating the system, it is advisable to start it for a preliminary test run in order to check that the system is properly installed.

5. MAINTENANCE

5.1 Any maintenance and/or repair must be carried out by qualified and authorized personnel only. Before any operation, make sure that the valve and the system is shut down and made unusable.

5.2 A correct maintenance helps extend the working life and grants a better performance of the valve.

5.3 It is necessary to check that the valve is clean outside, and that there is no sign of leakage and/or malfunctioning. If necessary, replace the involved parts. In case of doubts, contact General Pump Customer Service.

5.4 Replace the valve parts with only original spare parts.



IMPORTANT: After maintenance, make sure that the valve is re-assembled correctly and that the initial conditions are restored. Comply with the torque wrench setting values and adjust the pressure again as described above.



The valve shall not be tampered with for any reason and/or used for any purpose other than the use it had been designed for. In case of tempering, the manufacturer disclaims all responsibility as to the valve functioning and safety.

6. WARRANTY CONDITIONS

6.1 The period and conditions of warranty are specified in the purchase contract.

6.2 Warranty is voided in case the valve is used for improper purposes, used at higher performances than the rated ones, repaired with non-original spare parts or if it turns out to be damaged due to the non-compliance with the operating instructions or to unauthorized tampering.