

15 kW

**EcoGen™**  
**Residential Standby Generator**  
**Air-Cooled Gas Engine**

**INCLUDES:**

- True Power™ Electrical Technology
- Designed specifically for use with alternative energy and storage solutions
- Two Line LCD Multilingual Digital Evolution™ Controller (English/Spanish/French/Portuguese)
- Electronic Governor
- Standard Wi-Fi™ Remote Monitoring
- System Status & Maintenance Interval LED Indicators
- Sound Attenuated Enclosure
- Flexible Fuel Line Connector
- Direct-To-Dirt Composite Mounting Pad
- Natural Gas or LP Gas Operation
- Base Fascia
- 3 Year / 2000 Hour Limited Warranty
- Listed and Labeled by the Southwest Research Institute allowing installation as close as 18" (457 mm) to a structure.\*  
*\*Must be located away from doors, windows, and fresh air intakes and in accordance with local codes.*

[https://assets.swri.org/library/DirectoryOfListedProducts/ConstructionIndustry/973\\_DoC\\_204\\_13204-01-01\\_Rev8.pdf](https://assets.swri.org/library/DirectoryOfListedProducts/ConstructionIndustry/973_DoC_204_13204-01-01_Rev8.pdf)

Standby Power Rating  
 Model G007163-0 (Aluminum - Bisque) - 15 kW 60 Hz



Not for sale in California



**FEATURES**

- **INNOVATIVE ENGINE DESIGN & RIGOROUS TESTING** are at the heart of Generac's success in providing the most reliable generators possible. Generac's G-Force™ engine lineup offers added peace of mind and reliability for when you need it the most. The G-Force series engines are purpose built and designed to handle the rigors of extended run times in high temperatures and extreme operating conditions.
- **TRUE POWER™ ELECTRICAL TECHNOLOGY:** Superior harmonics and sine wave form produce less than 5% Total Harmonic Distortion for utility quality power. This allows confident operation of sensitive electronic equipment and micro-chip based appliances, such as variable speed HVAC systems.
- **EXTENDED RUN CAPABILITY:** This innovative oil circulation system extends the maintenance intervals by an unprecedented 5 times the industry standard by offering 500 hour maintenance intervals.
- **TEST CRITERIA:**
  - ✓ **PROTOTYPE TESTED**                      ✓ **NEMA MG1-22 EVALUATION**
  - ✓ **SYSTEM TORSIONAL TESTED**        ✓ **MOTOR STARTING ABILITY**
- **MOBILE LINK™ REMOTE MONITORING:** FREE with every Guardian Series Home standby generator. Allows you to monitor the status of your generator from anywhere in the world using a smartphone, tablet, or PC. Easily access information such as current operating status and maintenance alerts. Connect your account to your authorized service dealer for fast, friendly and proactive service. With Mobile Link, you are taken care of before the next power outage.
- **SOLID-STATE, FREQUENCY COMPENSATED VOLTAGE REGULATION:** This state-of-the-art power maximizing regulation system is standard on all Generac models. It provides optimized FAST RESPONSE to changing load conditions and MAXIMUM MOTOR STARTING CAPABILITY by electronically torque-matching the surge loads to the engine. Digital voltage regulation at ±1%.
- **SINGLE SOURCE SERVICE RESPONSE** from Generac's extensive dealer network provides parts and service know-how for the entire unit, from the engine to the smallest electronic component.
- **PURPOSE BUILT FOR RENEWABLE ENERGY APPLICATIONS:** Designed specifically to interact with off-grid renewable energy applications, EcoGen is the first generator intended for alternative energy interaction. Capable of tying into an inverter and battery storage system to supplement the alternative energy source. This provides the cleanest running, low emission solution to recharging house batteries.



\* Assembled in the USA using domestic and foreign parts.

# 15 kW

## Engine

- Generac G-Force design Maximizes engine “breathing” for increased fuel efficiency. Plateau honed cylinder walls and plasma moly rings help the engine run cooler, reducing oil consumption resulting in longer engine life.
- “Spiny-lok” cast iron cylinder walls Rigid construction and added durability provide long engine life.
- Electronic ignition/spark advance These features combine to assure smooth, quick starting every time.
- Oil circulatory system Extends maintenance intervals to 500 hours and virtually eliminates oil degradation.
- Full pressure lubrication system Pressurized lubrication to all vital bearings means better performance, less maintenance, and longer engine life.
- Low oil pressure shutdown system Shutdown protection prevents catastrophic engine damage due to low oil.
- High temperature shutdown Prevents damage due to overheating.

## Generator

- Revolving field Allows for a smaller, lightweight unit operating 25% more efficiently than a revolving armature generator.
- Skewed stator Produces a smooth output waveform for compatibility with electronic equipment.
- Displaced phase excitation Maximizes motor starting capability.
- Automatic voltage regulation Regulates the output voltage to ±1% prevents damaging voltage spikes.
- UL 2200 listed For your safety.

## Evolution™ Controls

- Auto/Manual/Off illuminated buttons Selects the operating mode and provides easy, at-a-glance status indication in any condition.
- Two-line LCD multi-lingual display Provides homeowners easily visible logs of history, maintenance and events up to 50 occurrences.
- Sealed, raised buttons Smooth, weather-resistant user interface for programming and operations.
- 2-wire Start Interconnection Allows the generator to be started by a two wire signal.
- Smart battery charger Delivers charge to the battery only when needed at varying rates depending on outdoor air temperature. Compatible with lead acid and AGM-style batteries.
- Main line circuit breaker Protects generator from overload.
- Electronic governor Maintains constant 60 Hz frequency.

## Unit

- SAE weather protective enclosure Sound attenuated enclosures ensure quiet operation and protection against mother nature, withstanding winds up to 150 mph (241 km/h). Hinged key locking roof panel for security. Lift-out front for easy access to all routine maintenance items. Electrostatically applied textured epoxy paint for added durability.
- Enclosed critical grade muffler Quiet, critical grade muffler is mounted inside the unit to prevent injuries.
- Small, compact, attractive Makes for an easy, eye-appealing installation, as close as 18" (457 mm) away from a building.

## Installation System

- 1 ft (305 mm) flexible fuel line connector Absorbs any generator vibration when connected to rigid pipe.
- Direct-to-dirt composite mounting pad Complex lattice design prevents settling or sinking of the generator system.
- Integral sediment trap Prevents particles and moisture from entering the fuel regulator and engine, prolonging engine life.

## Remote Monitoring

- Ability to view generator status Monitor your generator via your smartphone, tablet, or computer at any time via the Mobile Link application for complete peace of mind
- Ability to view generator Run and Total Hours Review the generator's complete protection profile for total run hours
- Ability to view generator maintenance information Provides maintenance information for your specific model generator when scheduled maintenance is due
- Monthly report with previous month's activity. Detailed monthly reports provide historical generator information
- Ability to view generator battery information Built in battery diagnostics displaying current state of the battery
- Weather information Provides detailed local ambient weather conditions for generator location.

# 15 kW

### Generator

<b>Model</b>	<b>G007163-0</b>
Rated Maximum Continuous Power Capacity (LP)	15,000 Watts*
Rated Maximum Continuous Power Capacity (NG)	15,000 Watts*
Rated Voltage	240
Rated Maximum Continuous Load Current – 240 Volts (LP/NG)	62.5 / 62.5
Total Harmonic Distortion	Less than 5%
Main Line Circuit Breaker	70 Amp
Phase	1
Number of Rotor Poles	2
Rated AC Frequency	60 Hz
Power Factor	1.0
Battery Requirement (not included)	12 Volts, Group 26R 540 CCA Minimum or Group 35AGM 650 CCA Minimum
Unit Weight (lb/kg)	460 / 209
Dimensions (L x W x H) in/mm	48 x 25 x 29 / 1218 x 638 x 732
Sound output in dB(A) at 23 ft (7 m) with generator operating at normal load**	66

### Engine

Type of Engine	GENERAC G-FORCE 1000 SERIES	
Number of Cylinders	2	
Displacement	999 cc	
Cylinder Block	Aluminum with Cast Iron Sleeve	
Valve Arrangement	Overhead Valve	
Ignition System	Solid-state with Magneto	
Governor System	Electronic	
Compression Ratio	9.5:1	
Starter	12 VDC	
Oil Capacity Including Filter	Approx. 3.75 qt / 3.55 L	
Operating rpm	3,600	
Fuel Consumption		
Natural Gas - ft <sup>3</sup> /hr (m <sup>3</sup> /hr)	1/2 Load	195 (5.52)
	Full Load	278 (7.87)
Liquid Propane - ft <sup>3</sup> /hr (gal/hr) [l/hr]	1/2 Load	66.8 (1.84) [6.95]
	Full Load	100 (2.76) [10.45]

Note: **Fuel pipe must be sized for full load.** Required fuel pressure to generator fuel inlet at all load ranges—3.5-7" water column (7-13 mm mercury) for natural gas, 10-12" water column (19-22 mm mercury) for LP gas. For BTU content, multiply ft<sup>3</sup>/hr x 2500 (LP) or ft<sup>3</sup>/hr x 1000 (NG). For Megajoule content, multiply m<sup>3</sup>/hr x 93.15 (LP) or m<sup>3</sup>/hr x 37.26 (NG)

### Controls

Two-Line Plain Text Multilingual LCD Display	Simple user interface for ease of operation.
Mode Buttons:Auto	Automatic start on utility failure.
Manual	Start with starter control, unit stays on. If utility fails, transfer to load takes place.
Off	Stops unit. Power is removed. Control and charger still operate.
Ready to Run/Maintenance Messages	Standard
Engine Run Hours Indication	Standard
Programmable start delay between 2-1500 seconds	Standard (programmable by dealer only)
Utility Voltage Loss/Return to Utility Adjustable (Brownout Setting)	From 140-171 V / 190-216 V
Run/Alarm/Maintenance Logs	50 events each
Engine Start Sequence	Cyclic cranking: Engine cranks a maximum of five times at factory set intervals and durations.
Starter Lock-out	Starter cannot re-engage until five seconds after engine has stopped.
Smart Battery Charger	Standard
Charger Fault/Missing AC Warning	Standard
Low Battery/Battery Problem Protection and Battery Condition Indication	Standard
Automatic Voltage Regulation with Over and Under Voltage Protection	Standard
Under-Frequency/Overload/Stepper Overcurrent Protection	Standard
Safety Fused/Fuse Problem Protection	Standard
Automatic Low Oil Pressure/High Oil Temperature Shutdown	Standard
Overcrank/Overspeed (@ 72 Hz)/rpm Sense Loss Shutdown	Standard
High Engine Temperature Shutdown	Standard
Internal Fault/Incorrect Wiring Protection	Standard
Common External Fault Capability	Standard
Field Upgradeable Firmware	Standard

\*\*Sound levels are taken from the front of the generator. Sound levels taken from other sides of the generator may be higher depending on installation parameters. Rating definitions - Standby: Applicable for supplying emergency power for the duration of the utility power outage. No overload capability is available for this rating. (All ratings in accordance with BS5514, ISO3046 and DIN6271). \* Maximum kilovolt amps and current are subject to and limited by such factors as fuel BTU/megajoule content, ambient temperature, altitude, engine power and condition, etc. Maximum power decreases about 3.5 percent for each 1,000 feet (304.8 meters) above sea level; and also will decrease about 1 percent for each 10 °F (6 °C) above 60 °F (16 °C).

## 15 kW

Model #	Product	Description
G005819-0	26R Wet Cell Battery	Every standby generator requires a battery to start the system. Generac offers the recommended 26R wet cell battery for use with all air-cooled standby product (excluding PowerPact®).
G007005-0	Wi-Fi LP Fuel Level Monitor	The Wi-Fi enabled LP fuel level monitor provides constant monitoring of the connected LP fuel tank. Monitoring the LP tank's fuel level is an important step in making sure your generator is ready to run during an unexpected power failure. Status alerts are available through a free application to notify when your LP tank is in need of a refill.
G007101-0	Battery Pad Warmer	The pad warmer rests under the battery. Recommended for use if the temperature regularly falls below 0°F (-18°C). (Not necessary for use with AGM-style batteries).
G007102-0	Oil Warmer	Oil warmer slips directly over the oil filter. Recommended for use if the temperature regularly falls below 0°F (-18°C).
G007103-1	Breather Warmer	The breather warmer is for use in extreme cold weather applications. For use with Evolution controllers only in climates where heavy icing occurs.
G005703-0	Paint Kit	If the generator enclosure is scratched or damaged, it is important to touch up the paint to protect from future corrosion. The paint kit includes the necessary paint to properly maintain or touch up a generator enclosure.
G006829-0	Scheduled Maintenance Kit	Generac's scheduled maintenance kits provide all the hardware necessary to perform complete routine maintenance on a Generac automatic standby generator.

## dimensions &amp; UPCs

Dimensions shown are approximate. Refer to installation manual for exact dimensions. DO NOT USE THESE DIMENSIONS FOR INSTALLATION PURPOSES.

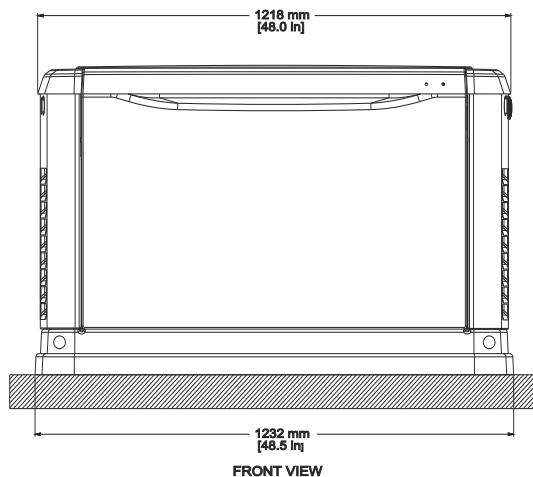
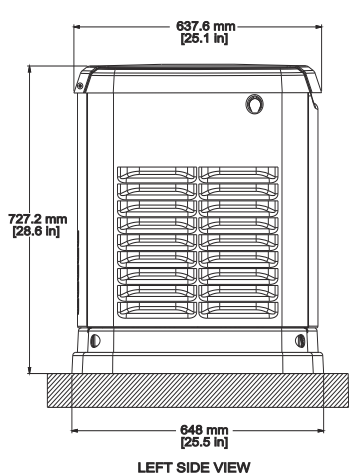

Model	UPC
G007163-0	696471074925