





# Baseboard Heater K Series



### Model Code:

4	K	24	10	BW	-HAL
A	B	C	D	E	F

A: Length  
 B: Series  
 C: Volts  
 D: Watts (375 to 2400)  
 E: Color (BW) Bright White (A) Almond  
 F: -HAL (High Altitude Limit)



- Aluminum ribbon fin element
- Full length safety cutout
- Crushproof element
- Natural convection heat
- Back wire design
- Built-in clamps coming soon
- Baked enamel finish
- Dent resistant die form cover
- 120, 208, 240 or 277 volts
- Available high altitude limit option
- Standard color: bright white (optional almond color)
- 1-year limited warranty

## The K Series Baseboard Heater

**Baseboard heaters** are an economical way to provide heat. They are typically used in apartment construction and other rental properties because of low initial cost and maintenance. Quality components guarantee a long-lasting, reliable heater. Standard color is bright white. Almond color available. Institutional grade 18 gauge front covers and 22 gauge back cans are available for special applications. All other specifications are the same as the standard heater.



### Dimensional Data Standard Backwire Junction Box

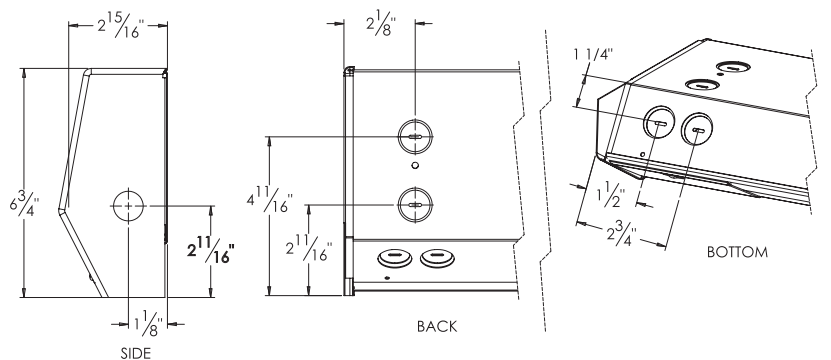

## Engineering Specifications

Contractor shall supply and install K Series electric convection baseboard heaters manufactured by King Electrical Mfg. Company of the wattage, voltage and length indicated on the plans.

### Construction:

- The heater shall take room air in the bottom (lower front) and discharge it through the top front.
- The heater front, back, bottom, and top shall be fabricated 22 gauge steel, ribbed longitudinally for extra strength and have center support to resist impact loads.
- The heater casing shall have modern rounded ends and corners to provide a smooth appearance, finished with a baked enamel.
- The heater shall be provided with a continuous capillary sensor tube for thermal protection, extending the full length of the heating element, rated at 175° F, and be a fail-safe type.

- The heater shall have a 44 cubic inch junction box at both ends, furnished with five  $\frac{1}{2}$ " knockouts located on the back, bottom, and side.
- Heater elements shall consist of high quality 80% Nickel and 20% Chromium alloy corrosion-resistant wire completely surrounded by Magnesium Oxide and enclosed in a rust-resistant sheath. Ribbon aluminum finning shall be compression welded to the sheathed element to provide chimney-type flue for heat transfer.
- Heaters shall be supplied with a one year limited warranty.

### Rating and Approval:

- The heaters shall be available in ratings from 375 through 1,500 Watts at 120 Volts, and 375 to 2,400 Watts at 208-240 and 277 Volts.
- The heaters shall be available in 187 or 250 Watts per lineal foot.
- cULus (E29778)

# Baseboard Heater K Series

**Ordering Information** Standard models Add suffix BW for bright white color and A for optional almond color.

	MODEL	VOLTS	WATTS	AMPS	LENGTH	SHIP WEIGHT lbs
<b>120V</b>	2K1205	120	500	4.2	27"	6.5
	3K1207	120	750	6.3	3 ft.	8
	4K1210	120	1000	8.3	4 ft.	10.5
	5K1212	120	1250	10.4	5 ft.	13
	6K1215	120	1500	12.5	6 ft.	15
<b>208V</b>	2K2005	208	500	2.4	27"	6.5
	3K2007	208	750	3.6	3 ft.	8
	4K2010	208	1000	4.8	4 ft.	10.5
	5K2012	208	1250	6.0	5 ft.	13
	6K2015	208	1500	7.2	6 ft.	15
<b>240V</b>	8K2020	208	2000	9.6	8 ft.	19
	8K2024	208	2400	11.5	8 ft.	19
	2K2405	240/208	500/375	2.1/1.8	27"	6.5
	3K2407	240/208	750/563	3.1/2.7	3 ft.	8
	4K2410	240/208	1000/750	4.2/3.7	4 ft.	10.5
<b>277V</b>	5K2412	240/208	1250/938	5.2/4.5	5 ft.	13
	6K2415	240/208	1500/1125	6.3/5.5	6 ft.	15
	8K2420	240/208	2000/1500	8.3/7.2	8 ft.	19
	8K2424	240/208	2400/1800	10.0/8.7	8 ft.	19
	2K2403	277	500	1.8	27"	6.5
<b>277V</b>	3K2405	277	750	2.7	3 ft.	8
	4K2407	277	1000	3.6	4 ft.	10.5
	5K2410	277	1250	4.5	5 ft.	13
	6K2412	277	1500	5.4	6 ft.	15
	8K2415	277	2000	7.2	8 ft.	19
8K2418	277	2400	9.0	8 ft.	19	

**Ordering Information** \*Low Density: 187 Watts per foot Add suffix BW for bright white color and A for optional almond color.

	MODEL	VOLTS	WATTS	AMPS	LENGTH	SHIP WEIGHT lbs
	2K2405	208	375	1.8	27"	6.5
	3K2407	208	563	2.7	3 ft.	8
	4K2410	208	750	3.6	4 ft.	10.5
	5K2412	208	938	4.5	5 ft.	13
	6K2415	208	1125	5.4	6 ft.	15
	8K2420	208	1500	7.2	8 ft.	19
	8K2424	208	1800	9.0	8 ft.	19
	2K2403	240	375	1.6	27"	6.5
	3K2405	240	563	2.3	3 ft.	8
	4K2407	240	750	3.1	4 ft.	10.5
	5K2410	240	938	3.9	5 ft.	13
	6K2412	240	1125	4.7	6 ft.	15
	8K2415	240	1500	6.3	8 ft.	19
	8K2418	240	1800	7.8	8 ft.	19

## Factory Installed Options

ADD SUFFIX	DESCRIPTION	SHIP WEIGHT lbs
BW	Bright White Color	0
A	Almond Color	0
-HAL	High Altitude Limit (For Baseboards Used Above 7,000 Feet Altitude)	N/A
-BK	Optional Backwire Junction Box	N/A

**Optional Backwire Junction Box**

**Crush Proof Design**

# Baseboard Heater Accessories K & CB Series

## Accessories

MODEL	UPC	DESCRIPTION	SHIP WEIGHT lbs
BKT1BW	11484	Built-In Thermostat Kit (SPST) - Bright White (Available in 5 Packs)	0.6
BKT2BW	11488	Built-In Thermostat Kit (DPST) - Bright White (Available in 5 Packs)	0.5
BKT1A	20657	Built-In Thermostat Kit (SPST) - Almond (Available in 5 Packs)	0.6
BKT2A	14889	Built-In Thermostat Kit (SPST) - Almond (Available in 5 Packs)	0.6
BKT1BW-TP	11542	Built-In Tamperproof Stat Kit (SPST) - Bright White (Available in 5 Packs)	0.3
BKT2BW-TP	11544	Built-In Tamperproof Stat Kit (DPST) - Bright White (Available in 5 Packs)	0.6
BKT-TIMER3HR-BW	11487	3 Hour spring wound timer/wire leads 16 amp/250 Vac. 15 Amp/125 Vac.	0.6
BKC-BW	11474	Corner Connector - Bright White, inside cover	1.5
BKR120-BW	11494	Duplex Cover Plate (includes 120V receptacle) - Bright White (See below)	0.5
BKLT120-BW*	11481	Load Transfer Cover Plate (Heat/Cool/Off) 120V - Bright White	0.5
BKLT240-BW*	11483	Load Transfer Cover Plate (Heat/Cool/Off) 240V - Bright White	0.5
BKCB1-BW	11532	3-3/4" Relay Control Box - Bright White	1.5
BKCB2-BW	11534	7-1/8" Dual Relay Control Box - Bright White	3.0

\*Requires BKCB1 Control box, order separately.

**Shield Options** \* Specify Color: Almond or White NON Cancel-able - NON Returnable item (NCNR)

MODEL	UPC	DESCRIPTION	SHIP WEIGHT lbs
SHIELD-33"	10290	Heater Shield for 27" Baseboard	6
SHIELD-42"	10291	Heater Shield for 3' Baseboard	7
SHIELD-54"	10292	Heater Shield for 4' Baseboard	8.5
SHIELD-66"	10293	Heater Shield for 5' Baseboard	10
SHIELD-78"	10294	Heater Shield for 6' Baseboard	11
SHIELD-102"	10295	Heater Shield for 8' Baseboard	14

**Cover Options** \* Specify Color: Almond or White NON Cancel-able - NON Returnable item (NCNR)

MODEL	UPC	DESCRIPTION	SHIP WEIGHT lbs
BB-18ga Cover 2'	52054	18 Gauge Cover for 27" Baseboard	1.5
BB-18ga Cover 3'	52056	18 Gauge Cover for 3' Baseboard	2
BB-18ga Cover 4'	52058	18 Gauge Cover for 4' Baseboard	2.6
BB-18ga Cover 5'	52060	18 Gauge Cover for 5' Baseboard	3.65
BB-18ga Cover 6'	52062	18 Gauge Cover for 6' Baseboard	4
BB-18ga Cover 8'	52064	18 Gauge Cover for 8' Baseboard	5.3

## Thermostats, Options & Accessories

