

HP Series

Radon Mitigation Fans



STANDARD FEATURES

- UV resistant, UL Listed durable plastic
- Vibration welded seam ensures leak proof housing
- Watertight electrical terminal box
- Totally enclosed for protection
- Automatic reset thermal overload protection

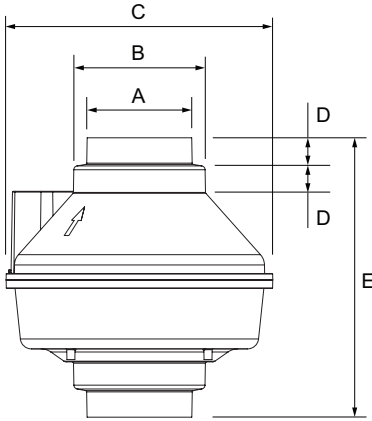

HP 175 / HP 190

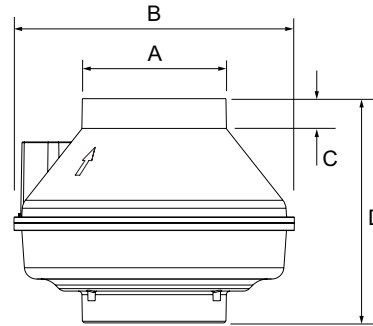

HP 220 / HP 2133 / HP 2190

Model	A	B	C	D	E	Weight	Certification
HP 175	3 31/32	4 31/32	10	1	10 9/16	2	HVI, cULus
HP 190	3 31/32	4 31/32	10	1	10 9/16	7	HVI, cULus

Model	A	B	C	D	Weight	Certification
HP 220	5 7/8	11 1/2	1 1/4	9 1/4	8	HVI, cULus
HP 2133	4 15/32	10	1 1/4	9 1/4	2	HVI, cULus, ENERGY STAR®
HP 2190	4 15/32	10	1 1/4	9 1/4	2	HVI, cULus

All dimensions in inches. Weights in pounds.

Fan Specifications							Motor Specifications				
Line	Qty	Model No.	Tag	CFM	SP	Fan RPM	Watts	Volts	Phase	Hertz	Encl
1											
2											
3											
4											

Accessory Items	1	2	3	4	Accessory Items	1	2	3	4

Project: _____ Submitted: _____
 Customer: _____ Approved: _____
 Location: _____

United States 10048 Industrial Blvd. • Lenexa, KS 66215 • 1.800.747.1762 • www.fantech.net
Canada 50 Kanalfakt Way • Bouctouche, NB E4S 3M5 • 1.800.565.3548 • www.fantech.net

Fantech reserves the right to make technical changes.
 For updated documentation please refer to www.fantech.net

