



Operator's Manual DLM-2100SP Mower

WARNING

This product contains chemicals known to the State of California to cause cancer, birth defects, or other reproductive harm. Cancer and Reproductive Harm www.P65Warnings.ca.gov

WARNING



Read and understand all provided literature before use. Failure to do so could result in serious injury.

Note: This product complies with CAN ICES-002 / NMB-002

99922238006

© 01/2023 ECHO Incorporated

TABLE OF CONTENTS

Introduction.....3

Servicing Information.....3

 Parts / Serial Number3

 Service.....4

 ECHO Consumer Product Support4

 Product Registration4

 Additional Literature.....4

Packing List4

Safety5

 Manual Safety Symbols and Important Information.....6

 International Symbols6

 Lawn Mower Safety Warnings.....7

 Environmentally Safe Battery Disposal13

 FCC Statement.....14

Description.....15

 Preparation For Use17

Operation.....23

 Starting The Unit.....23

 Stopping The Unit.....23

 Self-Propel Drive System24

 Operate on Slopes.....25

 Empty the Grass Catcher25

 Operation Tips26

Maintenance26

 Cleaning Battery and Battery Compartment.....28

 Replace The Blade29

Troubleshooting.....30

Storage32

 Vertical Storage32

 Storage After Use33

Specifications34

Product Registration35

Warranty37

INTRODUCTION

Specifications, descriptions and illustrative material in this literature are as accurate as known at the time of publication, but are subject to change without notice. Illustrations may include optional equipment and accessories, and may not include all standard equipment.



Read and understand all provided literature. Literature contains specifications and information for safety, operation, maintenance, storage, and assembly specific to this product. Scan QR code for more information.



For additional literature, including safety manuals where applicable, or questions regarding terms used in this manual, visit:

<https://www.echo-usa.com/manuals>



SERVICING INFORMATION

Parts / Serial Number

Genuine ECHO Parts and Assemblies for your ECHO products are available only from an Authorized ECHO Dealer. When you do need to buy parts always have the Model Number and Serial Number of the unit with you. For future reference write them in the space provided below.

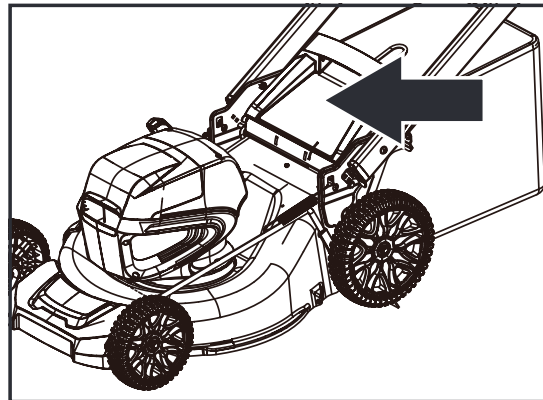

Model No. _____

Serial No. _____

Service

Service of this product during the warranty period must be performed by an Authorized ECHO Service Dealer. For the name and address of the Authorized ECHO Service Dealer nearest you, ask your retailer or call: 1-800-432-ECHO (3246). Dealer information is also available on our Web Site www.echo-usa.com. When presenting your unit for Warranty service/repairs, proof of purchase is required.

ECHO Consumer Product Support

If you require assistance or have questions concerning the application, operation, or maintenance of this product, call the ECHO Consumer Product Support Department at 1-800-432-ECHO (3246) from 8:00 am to 5:00 pm (Central Standard Time) Monday through Friday. Before calling, please know the model and serial number of your unit.

Product Registration

Register your ECHO equipment online at www.echo-usa.com or by filling out the product registration sheet included in this manual. Registering your product confirms warranty coverage and provides a direct link to ECHO if we find it necessary to contact you.

Additional Literature

In addition to finding information online, information is available from your Authorized ECHO Service Dealer, or by contacting ECHO Incorporated, 400 Oakwood Road, Lake Zurich, IL 60047, 1-800-432-ECHO (3246).

PACKING LIST

The ECHO product you purchased has been factory pre-assembled for your convenience. Due to packaging restrictions, some assembly may be necessary.

After opening the carton, check for damage. Immediately notify your retailer or ECHO Dealer of damaged or missing parts. Use the contents list to check for missing parts.

- 1 Mower
- 1 Operator's manual
- 1 Side discharge chute
- 1 Grass catcher
- 1 Mulch plug

Manual Safety Symbols and Important Information

Throughout this manual and on the product itself, you will find safety alerts and helpful, informational messages preceded by symbols or key words. The following is an explanation of those symbols and key words and what they mean to you.

DANGER

The safety alert symbol accompanied by the word “DANGER” calls attention to an act or condition which WILL lead to serious personal injury or death if not avoided.

WARNING

The safety alert symbol accompanied by the word “WARNING” calls attention to an act or condition which CAN lead to serious personal injury or death if not avoided.

CAUTION

The safety alert symbol accompanied by the word “CAUTION” calls attention to an act or condition which might lead to minor or moderate personal injury if not avoided.

NOTICE

The enclosed message provides information necessary for the protection of the unit.

Note: This enclosed message provides tips for use, care and maintenance of the unit.













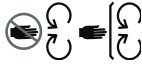

CIRCLE AND SLASH SYMBOL

This symbol means the specific action shown is prohibited. Ignoring these prohibitions can result in serious or fatal injury.

International Symbols

Some of the following symbols may be used on this product. Please study them and learn their meaning. Proper interpretation of these symbols will allow you to operate the product better and safer.

Symbol	Description	Symbol	Description
	WARNING! Read and follow all safety precautions in the operator's manual. Failure to follow instructions could result in serious personal injury.		Use extra caution on slopes. do not mow slopes greater than 15 degrees.
	Safety / Alert		Do not open or remove safety devices while the tool is running.
	Always wear eye protection with side shields marked to comply with ANSI Z87.1 when operating this equipment.		Look down and behind first to avoid tripping when pulling back.
	Do not expose the product to rain or moist conditions.		Direct current
	Remove objects that can be thrown by the blade in any direction.		Volts
	All visitors should be kept at a distance from work area.	 	To reduce the risk of injury, keep hands and feet away from rotating parts. Do not operate unless discharge cover or grass bag is in its proper place. If damaged, replace immediately.
	Environmentally safe battery disposal		

SAFETY

Lawn Mower Safety Warnings

WARNING

This machine was built to be operated according to the rules for safe operation included in this manual. As with any type of power equipment, carelessness or error on the part of the operator can result in serious injury. This machine is capable of amputating hands and feet and throwing objects. Failure to observe all safety instructions could result in serious injury or death.

When using electric lawn mowers, basic safety precautions should always be followed to reduce the risk of fire, electric shock, and personal injury. These basic precautions include the following:

Children and Bystanders

Tragic accidents can occur if the operator is not alert to the presence of children or bystanders.

- Keep the area of operation clear of all persons, particularly small children, and pets.
- Use extreme care when approaching blind corners, doorways, shrubs, trees, or other objects that may obscure your vision of a child or bystander. Keep children, bystanders, helpers and pets at least 100 feet (30m) from the mower while it is in operation. Stop the machine if anyone enters the area.
- Never allow children under 14 years old to operate a power mower. Operators 14 years old and over should fully read and understand the operator's manual and safety rules. Only responsible individuals who are familiar with these rules of safe operation should be allowed to use this machine.

General Operation

- Read this operator's manual carefully in its entirety before assembling or operating this machine. Read, understand, and follow all instructions on the machine and in the manuals before operation. Familiarize yourself with the controls and proper use of this machine before operation. Save this manual for future and regular reference.

- Do not use the lawn mower for any job except that for which it is intended. Your lawn mower has been designed to perform only one job: cut grass.
- Never attempt to make a wheel height adjustment while the motor is running.
- Don't force the lawn mower; it will do the job better and more safely at the rate for which it was designed.
- Don't overreach, keep proper footing and balance at all times. Many injuries occur as a result of the mower being pulled over the foot during a fall caused by slipping or tripping. A slip and fall can cause serious personal injury. If you feel you are losing your footing, release the control handle immediately and the blade will stop rotating within three seconds.
- Thoroughly inspect the area where the mower is to be used and remove all stones, sticks, wires, dog bones, and other foreign objects.
- Prevent unintentional starting. Ensure the switch is in the off position before connecting to battery, picking up or carrying the mower. Carrying the mower with your finger on the switch or energizing mower that has the switch on invites accidents.
- Never pull the mower back toward you while you are walking. If you must back the mower away from a wall or obstruction, first look down and behind you to avoid tripping, and then follow these steps:
 1. Step back from the mower in order to fully extend your arms.
 2. Be sure that you are well balanced.
 3. Pull the mower back slowly.
- Remove the battery from the mower before making any adjustments, changing accessories, or storing appliance. Such preventive safety measures reduce the risk of starting the mower accidentally.
- Before and while moving backwards with the mower, look behind and down for small children and other people.
- Do not operate the mower while under the influence of alcohol or drugs. Stay alert and watch what you are doing at all times. Use common sense and do not operate the lawn mower when you are tired.
- Always wear safety glasses or safety goggles during operation and while performing an adjustment or repair to protect your eyes. Thrown objects that ricochet can cause serious injury to the eyes. Always use a face or dust mask if the operation is dusty.
- Keep clear of the discharge opening at all times. Do not put hands or feet near rotating parts or under the cutting deck. Contact with the blade can amputate hands and feet.
- Plan your mowing pattern to avoid discharge of material toward roads, sidewalks, bystanders and the like. Also, avoid discharging material against walls or obstructions, which may cause discharged material to ricochet back toward the operator.

- To help avoid the blade or an injury from a thrown objects, stay in the operator zone behind the handles.
- A missing or damaged discharge cover can cause blade contact or injuries from thrown objects.
- Objects struck by the lawn mower blade can cause severe injuries to persons. The lawn should always be carefully examined and cleared of all objects prior to each mowing.
- Stop the blade when crossing gravel drives, walks or roads.
- Follow all charging instructions and do not charge the battery or mower outside of the temperature range specified in the instructions. Charging improperly or at temperatures outside of the specified range may damage the battery and increase the risk of fire.
- If lawn mower strikes a foreign object, follow these steps:
 1. Release the bail switch to disengage the motor.
 2. Remove the battery.
 3. Inspect for damage.
 4. Repair any damaged parts before restarting and operating the lawn mower.
- Dress properly; do not wear loose clothing or jewelry that can be caught in moving parts. Use of safety gloves and proper footwear is recommended when working outdoors. Wear sturdy, rough-soled work shoes and close-fitting slacks and shirts. Shirts and pants that cover the arms and legs and steel-toed shoes are recommended. Never operate this machine in bare feet, sandals, slippery or lightweight (e.g., canvas) shoes.
- Wear protective hair covering to contain long hair.
- Avoid dangerous environments; do not use the lawn mower in damp/wet locations or if it is raining.
- Store idle lawn mower indoors. When not in use, appliances should be stored indoors in dry, and high or locked-up place – out of reach of children. Always remove the battery from the mower before storing.
- Mow only in daylight or good artificial light. Walk, never run while operating.
- If the mower should start to vibrate abnormally, immediately stop the motor, remove the battery and check for the cause. Vibration is generally a warning that the mower is not functioning properly.
- Check bag frequently for deterioration and wear, and replace worn bags. Check that replacement bags comply with the original manufacturer's recommendations or specifications.
- Before cleaning the mower, unclogging or removing the grass bag, mulching insert, or side discharge chute, turn the motor off and wait until the blade comes to a complete stop, then remove the battery. The cutting blade continues to rotate for a few seconds after the motor is shut off. Never perform these functions until you are sure the blade has stopped rotating.

- Never operate the mower without the proper discharge cover, grass bag, mulching insert, side discharge chute, or other safety devices in place and working. Never operate the mower with damaged safety devices. Failure to do so can result in personal injury.
- Use only ECHO eFORCE™ 56V series batteries and chargers. Other batteries and chargers may cause damage to the mower or injure the operator.
- Do not dispose of the battery in a fire. The cells could catch fire or explode. Check with local codes and waste management for proper disposal instructions.
- When battery is not in use, keep it away from other metal objects, like paper clips, coins, keys, nails, screws or other small metal objects that can make a connection from one terminal to another. Shorting the battery terminals together may cause burns or a fire.
- Do not open or destroy the battery. Electrolytes contained within the battery are corrosive and may cause damage to eyes or skin if released. It may be toxic if swallowed.
- Under abusive conditions, liquid may be ejected from the battery; avoid contact. If contact accidentally occurs, flush with water. If liquid contacts eyes, additionally seek medical help. Liquid ejected from the battery may cause irritation or burns.
- Do not expose a battery or appliance to fire or excessive temperature. Exposure to fire or temperature above 130°C may cause explosion.
- Exercise care in handling batteries to avoid shorting the battery with conducting materials such as rings, bracelets, keys, etc. The battery or conductor may overheat and cause burns if contact with said materials is made.
- Do not use a battery or appliance that is damaged or modified. Damaged or modified batteries may exhibit unpredictable behavior resulting in fire, explosion or risk of injury.

Service/Maintenance

- Check the blade and the motor (machine) mounting bolts at frequent intervals for proper tightness.
- Replace the blade if it is bent or cracked. An unbalanced blade causes vibration that could damage the motor drive unit or cause personal injury.
- Keep all nuts, bolts, and screws tight in order to ensure the equipment is in safe working condition.
- Do not wash with a hose; avoid getting water in motor and electrical connections.
- Never remove or tamper with safety devices. Check their proper operation regularly. Never do anything to interfere with the intended function of a safety device or to reduce the protection provided by a safety device.
- Keep mower free of grass, leaves, or other debris build up. Allow mower to

- cool before storing.
- Never make any adjustments or repairs with the motor running.
 - Always remove battery from mowers before adjusting, cleaning, or repairing.
 - Check grass catcher components and the discharge guard frequently and replace with manufacturer's recommended parts, when necessary.
 - Sharpen a dull blade equally at each end to maintain the balance.
 - Keep guards in place and in working order. Mower blades are sharp, and can cut. Wrap the blades or wear gloves, and use extra caution when servicing.
 - Clean the blade thoroughly and check its balance by supporting it horizontally on a thin nail through its center hole. The nail should also be in a horizontal position. If either end of the blade rotates downward, remove some metal from the heavy or lower end until the blade is balanced. It is balanced when neither end drops.
 - Use identical replacement blades only.
 - Maintain lawn mower with care. Keep cutting edges sharp and clean for best and safest performance. Follow instructions for lubricating and changing accessories. Inspect lawn mower cord periodically and if damaged, have it repaired by an authorized service facility.
 - If situations occur that are not covered in this manual, use care and good judgment or contact Customer Service for assistance.
 - Never operate the mower without proper guards, plates, or other safety protective devices in place.
 - Before each use, examine the machine for damaged, missing, or loose parts such as screws, nuts, bolts and caps.
 - Tighten correctly all the fasteners and caps.
 - Clean the machine with a dry cloth. Do not use water.
 - Have servicing performed by a qualified repair person using only identical replacement parts. This will ensure that the safety of the product is maintained.
 - Do not modify or attempt to repair the mower or the battery (as applicable) except as indicated in the instructions for use and care.
 - Never service damaged batteries. Service of batteries should only be performed by the manufacturer or authorized service providers.

The recommended ambient temperature range:

Item	Temperature
Mower storage temperature range	32 °F (0 °C) ~ 113 °F (45 °C)
Mower operation temperature range	32 °F (0 °C) ~ 113 °F (45 °C)
Battery charging temperature	39 °F (4 °C) ~ 104 °F (40 °C)
Charger operation temperature range	39 °F (4 °C) ~ 104 °F (40 °C)
Battery storage temperature range	32 °F (0 °C) ~ 113 °F (45 °C)
Battery discharging temperature range	32 °F (0 °C) ~ 113 °F (45 °C)

Slope Operation

Slopes are a major factor related to slip-and-fall accidents, which can result in severe injury. Operation on slopes requires extra caution. If you feel uneasy on a slope, do not mow it.

Do:

- Mow across the face of slopes; never mow up and down. Exercise extreme caution when changing direction on slopes.
- Watch for holes, roots, rocks, hidden objects, or bumps which can cause you to slip or trip. Tall grass can hide obstacles. Remove all obstacles such as rocks and tree limbs.
- Make sure that your footing is stable. If you are out of balance, release the switch immediately.

Do not:

- Mow near drop-offs, ditches or embankments; you could lose your footing or balance.
- Mow slopes greater than 15 degrees.
- Mow on wet grass. Unstable footing could cause slipping.



***If you are not comfortable, do not mow on a slope.
In case of self-propelled mowers, please keep a low self-propelled speed when you mow on a slope.***

Environmentally Safe Battery Disposal

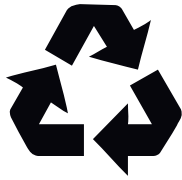

The toxic and corrosive materials below are in the batteries used in this machine: Lithium-Ion, a toxic material.

Discard all toxic materials in a specified manner to prevent contamination of the environment. Before discarding damaged or worn out Li-ion battery, contact your local waste disposal agency, or the local Environmental Protection Agency for information and specific instructions. Take the batteries to a local recycling and/or disposal center, certified for lithium-ion disposal.

If the battery cracks or breaks, with or without leaks, do not recharge it and do not use. Discard it and replace with a new battery. **DO NOT TRY TO REPAIR IT!** To prevent injury and risk of fire, explosion, or electric shock, and to avoid damage to the environment:

- Cover the terminals of the battery with heavy-duty adhesive tape.
- DO NOT try to remove or destroy any of the battery components.
- DO NOT try to open the battery.
- If a leak develops, the released electrolytes are corrosive and toxic. DO NOT get the solution in the eyes or on skin, and do not swallow it.
- DO NOT put these batteries in your regular household trash.
- DO NOT incinerate.
- DO NOT put them where they will become part of any waste landfill or municipal solid waste stream.
- Take them to a certified recycling or disposal center.

FCC Statement

This device complies with Part 15 of the FCC Rules. Operation is subject to the following two conditions:

- This device may not cause harmful interference.
- This device must accept any interference received, including interference that may cause undesired operation.

CAUTION

Changes or modifications not expressly approved by the party responsible for compliance could void the user's authority to operate the equipment.

NOTICE

This equipment has been tested and found to comply with the limits for a Class B digital device, pursuant to Part 15 of the FCC Rules.

These limits are designed to provide reasonable protection against harmful interference in a residential installation. This equipment generates, uses and can radiate radio frequency energy, and if not installed and used in accordance with the instructions, may cause harmful interference to radio or television reception. The reception can be determined by turning the equipment off and on. The user is encouraged to try to correct the interference by one or more of the following measures:

- *Reorient or relocate the receiving antenna.*
- *Increase the separation between the equipment and the receiver.*
- *Connect the equipment into an outlet on a circuit different from that to which the receiver is connected.*
- *Consult the dealer or an experienced radio/TV technician for help.*

DESCRIPTION

Locate the safety label(s) on your unit. Make sure the label(s) is legible and that you understand and follow the instructions on it. If a label cannot be read, a new one can be ordered from your ECHO dealer. Safety label is for example only. Your label may appear slightly different.

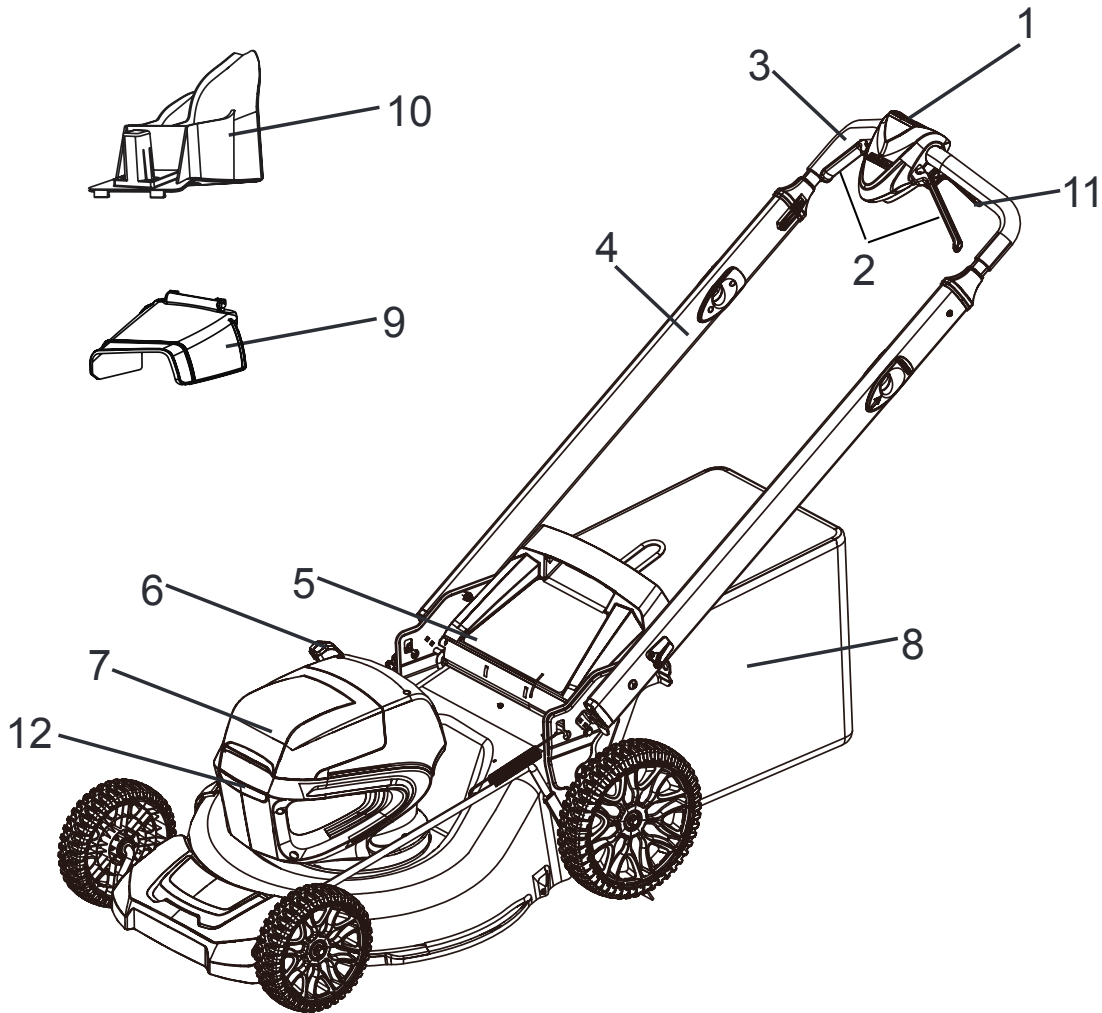

1. Start button
2. Start handle
3. Upper handle
4. Lower handle
5. Rear discharge door
6. Height adjustment lever
7. Battery door
8. Grass catcher
9. Side discharge chute
10. Mulch plug
11. Self-propel drive lever
12. Headlight

Preparation For Use

NOTICE

Do not damage the cable while installing the upper handle.

Install the Upper Handle

1. Place the mower upright in vertical position.
2. Remove the packing material from the cable.
3. Remove the rubber edge guard from the upper handle.

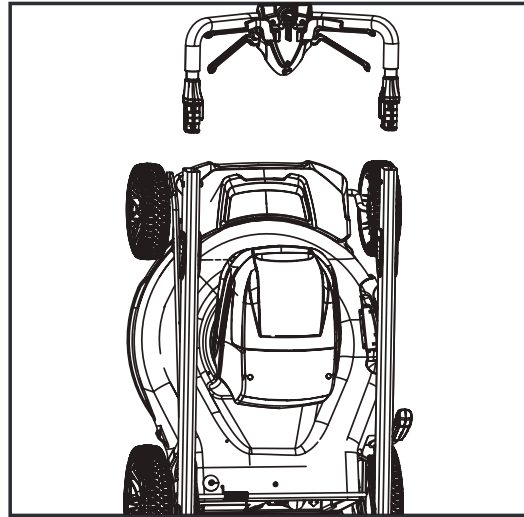

4. Insert the upper handle (3) into the lower handle (4).
5. Put the bolts (25) through the holes and tighten with the nuts (26), using a screwdriver (not included).

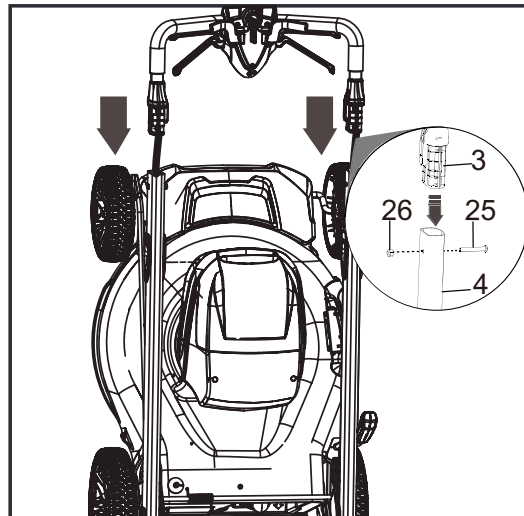

NOTICE

Make sure that the two handle pins are in the same position.

Unfold the Lower Handle

1. Pull up on the handle holes (13) to release the lower handles (4).

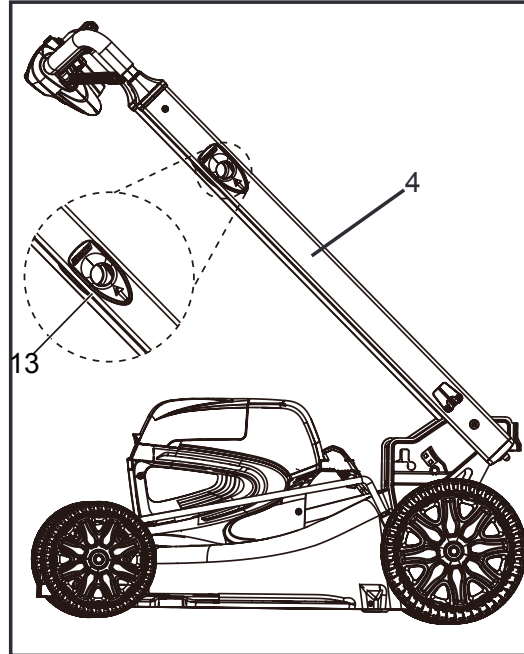

2. Fold the lower handle up until the handle pins (P) lock into position.

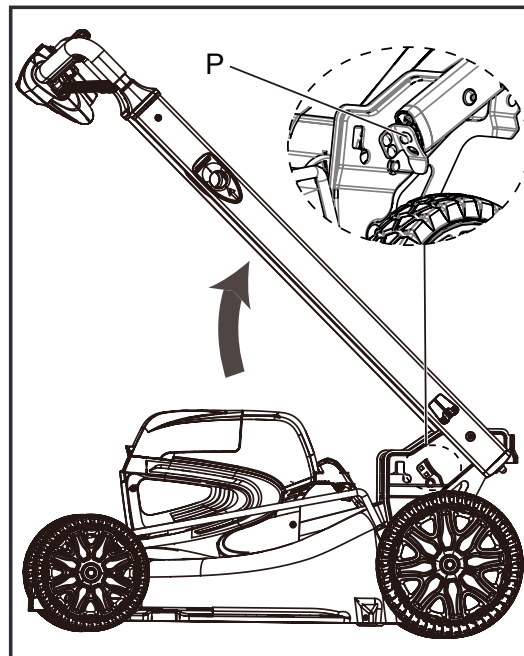

Mower Functions

In general, a lawn mower is featured with three functions (rear bagging/ mulching/ side discharging). These functions can be converted by changing accessory setting. Please see the following table for detail setting.

To Convert Mower	Mulch Plug	Grass Bag	Side Discharge Chute
For rear bagging	×	√	×
For mulching	√	×	×
For side discharging	√	×	√

Install the Grass Catcher

1. Remove the battery and safety key.
2. Remove the mulch plug.
3. Remove the side discharge chute.
4. Open the rear discharge door and hold it.

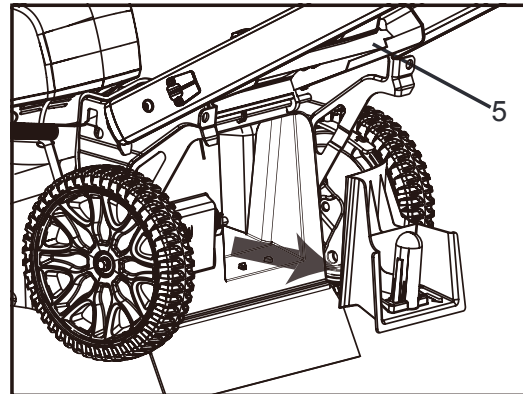

5. Hold the the grass catcher (8) by its handle and engage the hooks (14) on the door rod (15).
6. Close the rear discharge door.

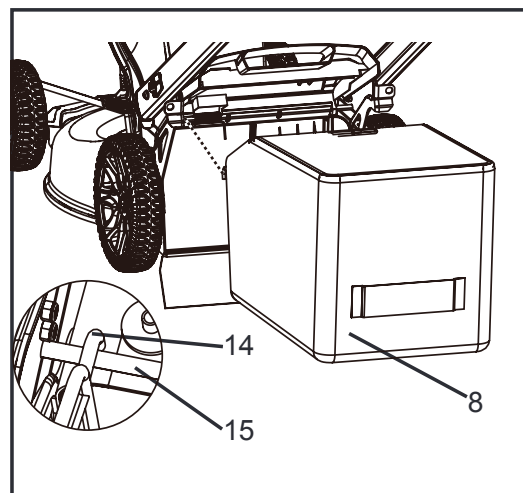

Install the Mulch Plug

1. Remove the battery and safety key.
2. Remove the grass catcher.
3. Open the rear discharge door (5) and hold it.
4. Hold the mulch plug (10) by its handle and fit it in the discharge chute.
5. Close the rear discharge door.

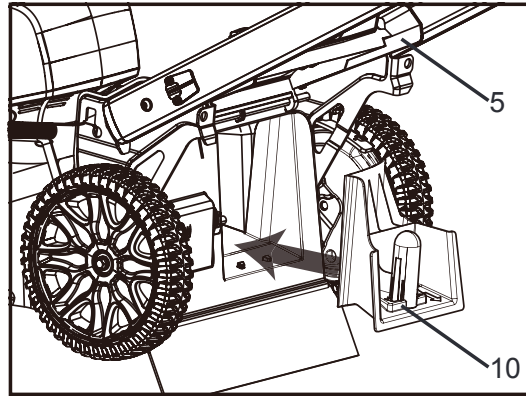

Install the Side Discharge Chute

WARNING

When you use the side discharge chute,

- ***Do not install the grass catcher.***
- ***Keep the mulch plug installed.***

1. Remove the battery and safety key.
2. Open the side discharge door (16) and hold it.
3. Line up the recesses of the side discharge chute (9) below the pivot.
4. Close the side discharge door.

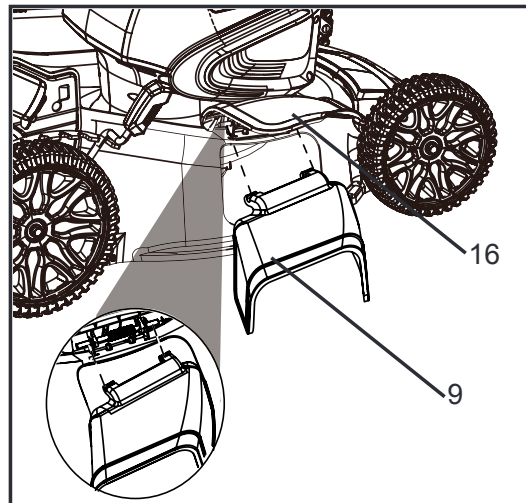

Set the Cutting Height

The machine can be set to different cutting heights.

1. Pull the height adjustment lever (6) rearward to increase the cutting height.
2. Pull the height adjustment lever forward to decrease the cutting height.

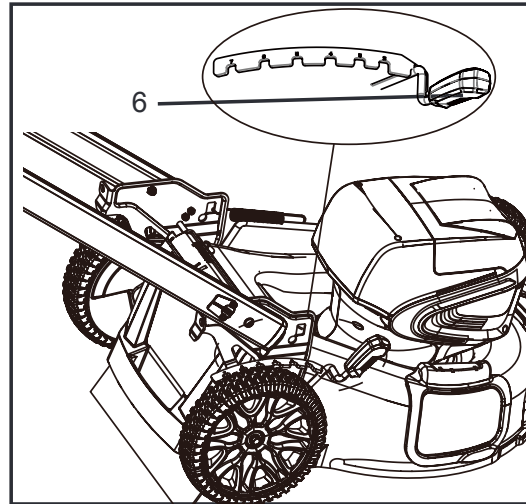

Installing and Removing the Battery

NOTICE

The machine has an automatic switch function that lets the other battery work when the first cannot operate.

The battery comes partially charged from the factory and needs to be fully charged before first use.

Note: See separate Operator's Manual Packaged with the Battery.

Installing the Battery

1. Lift and hold up the battery door (17).
2. Align the battery with the mower's battery port.
3. Make sure the battery release button (18) snaps in place and that battery is fully seated and secure in the mower before beginning operation.
4. Insert the safety key (19).
5. Close the battery door.

Note: The machine has an automatic switch function that lets the other battery work when the first cannot operate. Extra battery can be purchased from dealer.

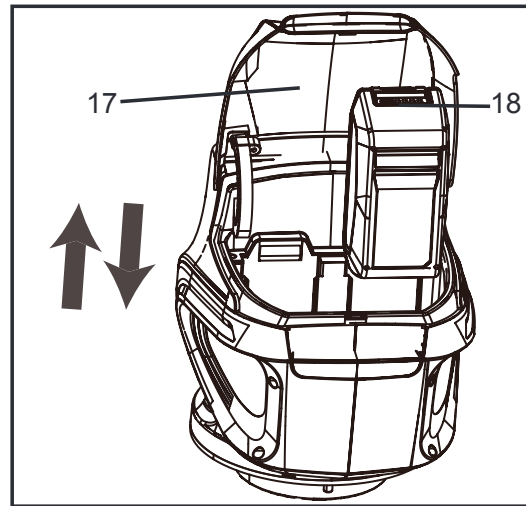

Removing the Battery

1. Stop the machine.
2. Open the battery door (17).
3. Remove the safety key (19).
4. Press the battery release button (18) on the mower. This will cause the battery to raise out of the tool slightly.
5. Remove battery from the product.

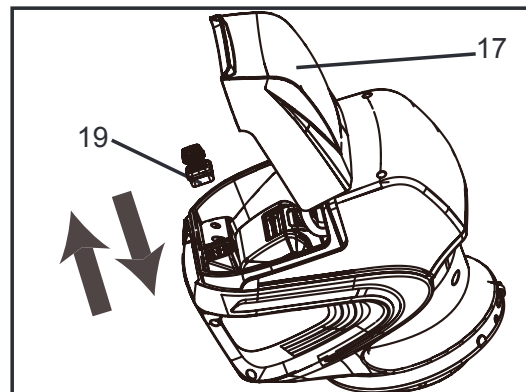

Starting the unit

WARNING

When starting the unit, observe the precautions described in the "Safety" section. Failure to observe the precautions could cause an accident or injury, or even lead to a fatality.

Wait until the blade fully stops before you start the machine again. Do not quickly turn the machine off and on.

1. Make sure safety key is inserted into slot.
2. Push and hold the start button (1).
3. While you hold the start button (1), grab the start handle (2) in the direction of the handle bar.
4. Once the machine has started, you can release the start button.
5. Press Turbo button (20) to speed up.
6. Press LED light button (21) to turn on the LED headlights.

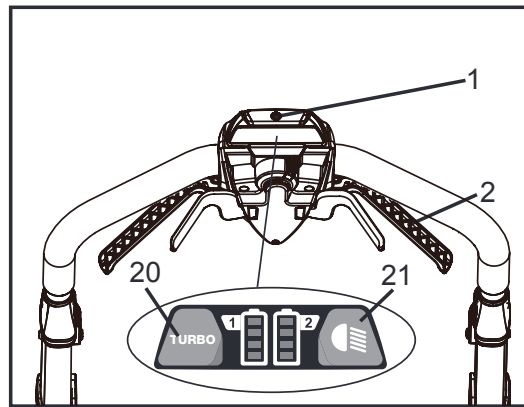

Stopping the unit

1. Release the start handle to stop the machine.

Note: Always remove the safety key and battery after you complete the work.

Self-Propel Drive System

1. Start the machine.
2. While you hold the start handles (2), grab either of the drive levers (11) and pull towards the handle bar.
3. Hold the start handles and the drive levers at the same time.
4. Release either set of start handle (2) and drive lever (11) from the same side.
5. Adjust the speed control (22) with your free hand.
 - Slide the speed control button in the direction of the Rabbit Symbol to increase the speed.
 - Pull the speed control button in the direction of the Turtle Symbol to decrease the speed.
6. Release the drive levers to disengage the self-propel system.

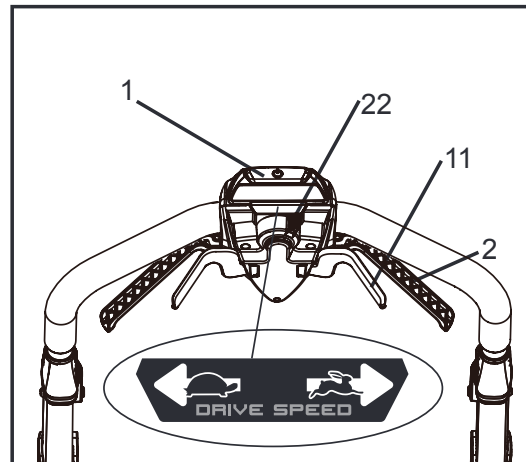

To engage the self-propel drive system while the mower is not running:

- Press and hold the start button (1), then pull up on the drive lever (11) or pull up on the drive lever (11), then press the start button (1).

Operate on Slopes

WARNING

Do not mow on the slopes with incline more than 15 degrees. If you are not comfortable, do not mow on a slope. Please keep a low self-propelled speed when you mow on a slope.

- Do not go up and down on a slope, mow across the face of the slope. Be careful when you change the direction on a slope.
- Monitor the holes, ruts, rocks, and other hidden objects that can cause you to fall. Remove all obstacles such as rocks and tree limbs.
- Make sure that your footing is stable. If you are out of balance, release the start handle immediately.
- Do not mow near drop-offs, ditches, or embankments.

Empty the Grass Catcher

1. Stop the machine.
2. Remove the safety key.
3. Remove the battery.
4. Open the rear discharge door and hold it.
5. Hold the grass catcher by its handle and unhook it from the door rod.
6. Close the rear discharge door.
7. Empty the grass catcher.



Operation Tips

- Do not try to override the operation of the start button or start handles.
- Do not tilt the machine when you start it.
- Do not put hands or feet near or below the turning parts.
- Keep the discharge chute clean.
- Cut wet grass will require more power and shorten run time.
- Higher blade height is necessary for new or thick grass.
- Clean the bottom of the mower deck after each use. Remove grass clippings, leaves, dirt, and other debris.

MAINTENANCE

WARNING

Moving parts can amputate fingers or cause severe injuries. Keep hands, clothing and loose objects away from all openings. Always stop motor, and make sure all moving parts have come to a complete stop before removing obstructions, clearing debris, or servicing unit. Allow unit to cool before performing service. Wear gloves to protect hands from sharp edges and hot surfaces.

WARNING

Operating a poorly maintained unit can result in serious injuries to operator or bystanders. Always follow all maintenance instructions as written, otherwise serious personal injury can result.

Your unit is designed to provide many hours of trouble free service. Regular scheduled maintenance will help your unit achieve that goal. If you are unsure or are not equipped with the necessary tools, we recommend that you take your unit to a Servicing Dealer for maintenance. To help you decide whether you want to DO-IT-YOURSELF or have the Dealer do it, each maintenance task has been graded. If the task is not listed, see your Dealer for repairs.

Skill Levels

Level 1 = Easy to do. Common tools may be required.

Level 2 = Moderate difficulty. Some specialized tools may be required.

Level 3 = See your dealer.

Maintenance Intervals

COMPONENT / SYSTEM	MAINTENANCE PROCEDURE	REQ'D SKILL LEVEL
Daily or Before Use		
Blade	Inspect / Replace *	2
Screws / Nuts / Bolts	Inspect / Tighten / Replace *	1

NOTICE - Time intervals shown are maximum. Actual use and your experience will determine the frequency of required maintenance.

MAINTENANCE PROCEDURE NOTES:

* Replacement is recommended based on the finding of damage or wear during inspection.

Cleaning Battery and Battery Compartment

WARNING

Risk of electric shock or fire. Do not use conducting materials to clean battery or battery compartment.

Remove the safety key and battery from the machine before maintenance.

1. Open the battery door (17).
2. Depress battery release button (18) and slide battery out of battery compartment.

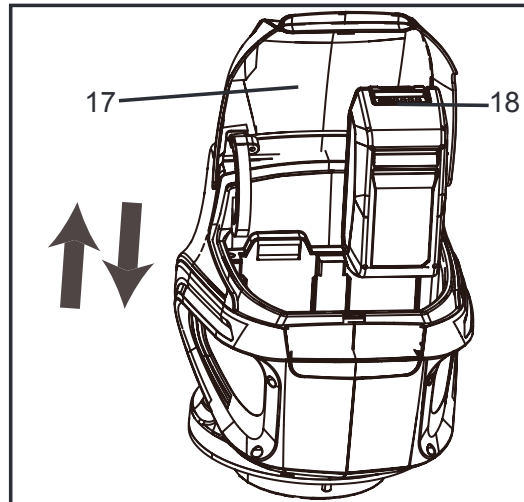

3. Remove the safety key (19).

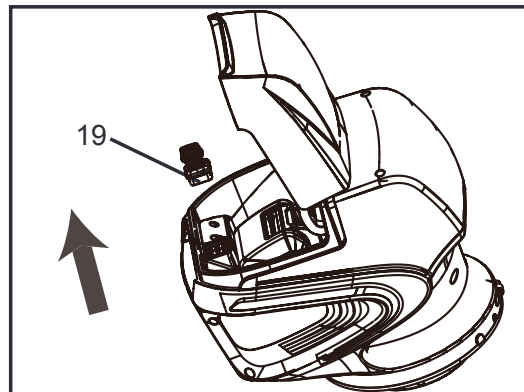

4. Use compressed air or a soft bristle brush to remove debris from battery and battery compartment (23).

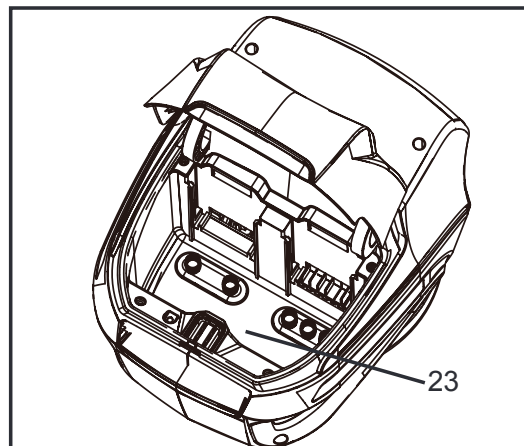

Replace The Blade

WARNING

Use only approved replacement blades.

Wear heavy gloves or wind cloth around the blade when you touch the blade.

1. Stop the machine.
2. Make sure that the blade fully stops.
3. Remove the safety key and batteries.
4. Turn the machine to its side.
5. Use a piece of wood or special lawnmower blade holding tool to prevent the movement of the blade.
6. Remove the mounting bolt (26) and spacer (25) with a wrench or socket.
7. Remove the blade (24).

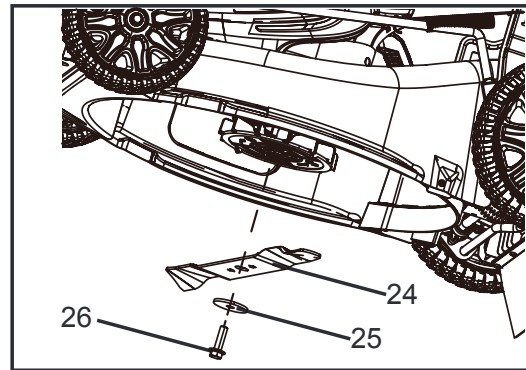

8. Install the new blade. Make sure the arrows on the fan engage the holes on the blade.
9. Put in the mounting bolt and spacer and tighten them. Recommended tightening torque: 33-37 Nm.

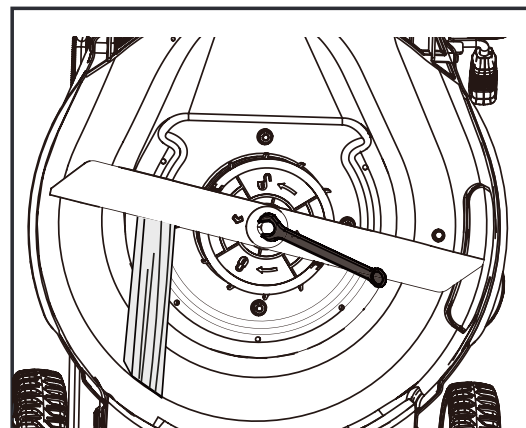

TROUBLESHOOTING

Problem	Cause	Solution
The lawn mower does not start.	The battery is not charged.	Charge the battery.
	The switch is defective.	Replace the switch (Contact an authorized dealer).
	Grass jammed between the deck and blade.	Remove battery and safety key; check under deck for jams.
	The battery is not fully inserted in the lawn mower.	Check the connection between the battery and the lawn mower. Make sure the battery clicks into place.
	Battery may require service or replacement.	Contact your dealer or replace battery.
The lawn mower cuts the grass unevenly.	The lawn is rough or uneven.	Check the mowing area.
	The cutting height is not set properly.	Move the wheels to a higher setting.
	The blade is dull.	Sharpen or replace the blade.
The lawn mower does not mulch properly.	Wet grass clippings are sticking to the underside of the deck.	Remove the battery and clean the unit. Wait until the grass dries before mowing.
	The mulching plug is missing.	Install the mulching plug.

Problem	Cause	Solution
The lawn mower is hard to push.	The grass is too tall, or the cutting height is too low.	Raise the cutting height.
	The rear of the grass catcher bag is dragging in thick grass.	Empty the grass clippings from the grass catcher bag.
The lawn mower is excessively noisy and vibrates.	The motor shaft is bent.	Stop the motor, and inspect for damage. Contact your dealer for repair.
	The blade is unbalanced.	Repair before restarting. If vibration persists, contact your dealer.

Number of Beeps	Symptom	Remedy
1	Mower will not start.	Consult authorized dealer.
2	Mower stops running.	Allow mower to cool. If problem persists, consult authorized dealer.
3	Mower will not start.	Check battery and terminals for corrosion or debris. If problem persists, consult authorized dealer.
4	Mower will start then stop, or will not start.	Start mower, at first not making a full cut, then proceed to cut normally. If problem persists, consult authorized dealer.
5	Mower will not start.	Fully charge battery and try again. If problem persists, consult authorized dealer.
6	Mower stops running.	Allow battery to cool. If problem persists, consult authorized dealer.
7	Mower will start then stop, or will not start.	Move mower to level ground and try again. If problem persists, consult authorized dealer.
8	Blade will not turn.	Remove batteries and safety key, remove obstruction, try again.
9	Motor will not reach full speed.	Start mower, at first not making a full cut, then proceed to cut normally. If problem persists, consult authorized dealer.

STORAGE

Vertical Storage

Do not store your unit without performing protective storage maintenance which includes the following:

1. Remove the grass catcher.
2. Remove the battery and safety key.
3. Pull through the handle holes to fold away the handles.

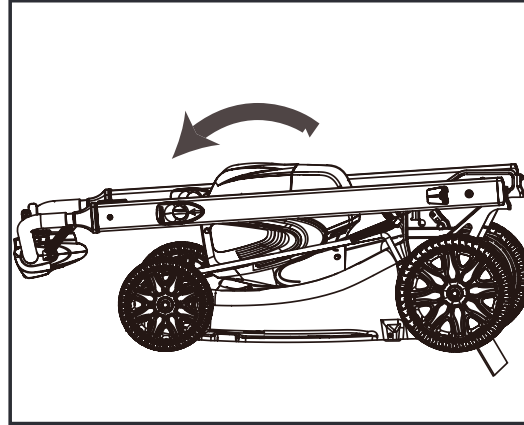

4. Lock the handles into position.
5. Stand the machine on end and make sure that the brackets touch the floor.

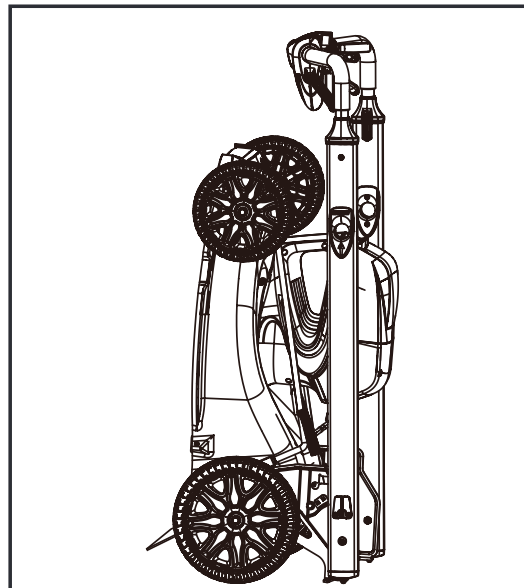

Storage After Use

When storing the product for long periods of time, ensure that the following preparations for storage are carried out.

Mower

Do not store your unit without performing protective storage maintenance which includes the following:

1. Turn power to unit off.
2. Remove battery from mower.
3. Remove accumulation of dirt and debris from exterior of unit.
4. Tighten all screws and nuts.
5. Close the battery door.
6. Store unit in a dry, dust-free place, out of the reach of children.

Battery

1. Remove battery from mower.
2. Store in a dry, dust-free place, out of the reach of children.
3. Store in temperatures between -4°F (-20°C) and 140°F (60°C).
4. If battery is stored for longer than six months, charge it to 100% capacity.

Charger

1. Remove battery from charger.
2. Disconnect charger from power supply.
3. Store in a dry, dust-free place, out of the reach of children.

SPECIFICATIONS

MODEL	DLM-2100SP
No-load speed	2800 RPM, 3200 RPM
Height adjustments	1 - 4" (3 - 10 cm)
Self-propelled speed	1.35 - 2.95 MPH (0.6 - 1.3 m/s)
Functions	3-in-1 Mulch & Rear Bag & Side discharge
Weight	65.48 lbs (29.7 kg)
Battery:	
Model	ECHO eFORCE™ 56V battery series batteries
Type	Li-Ion
Voltage	56 (rated 50.4)
Charger type	CCCV
Charger input voltage	120V AC 60Hz
Charger model	ECHO eFORCE™ 56V battery series charger
Charger Lights	
○ OFF ● Green blinking	Battery is charging
○ OFF ● Green	Fully charged
● Red ○ OFF	Battery is too warm: (Remove for approx.30 minutes to allow to cool)
● Red blinking ○ OFF	Defective battery: (Remove and replace with new battery if this occurs)
Charge Time	See Battery Operator's Manual

PRODUCT REGISTRATION

Thank you for choosing ECHO Power Equipment

Please go to <http://www.echo-usa.com/Warranty/Register-Your-ECHO> to register your new product online. It's FAST and EASY! NOTE: your information will never be sold or misused by ECHO, Incorporated.

Registering your purchase enables us to contact you in the unlikely event of a service update or product recall, and verifies your ownership for warranty consideration.

If you do not have access to the Internet, you can complete the form below and mail to:

***ECHO Incorporated, Product Registration, PO Box 1139,
Lake Zurich, IL 60047.***

ECHO PRODUCT REGISTRATION CARD : TARJETA DE REGISTRO : CARTE D'ENREGISTREMENT DU PRODUIT

<p>ONLINE OPTION: Register online and save a stamp! You will be alerted of product updates and/or be sent new ECHO product information and special offers. Simply go to: www.echo-usa.com</p>	<p>OPCIÓN POR INTERNET: ¡Regístrese en la página web y ahorre una estampilla! Le alertarán sobre actualizaciones del producto y/o se le enviará información sobre los nuevos productos ECHO y las ofertas especiales. Simplemente visite: www.echo-usa.com</p>	<p>OPTION EN LIGNE : Enregistrer en ligne et épargner un timbre! Vous serez informé sur les nouveaux produits ECHO et les mises à jour de produit ainsi que les offres spéciales. Simplement visitez le: www.echo-usa.com</p>
--	---	--

Please Print : Por Favor Enscriba Con Letra De Molde : En Lettre Carré S.V.P. Confidential: Information provided will not be shared or sold

Purchaser's Name : Nombre del Comprador : Nom de l'acheteur	
Address : Dirección : Adresse	
City : Ciudad : Ville	State : Estado : Province
Zip Code : Código Postal : Code Postal	
E-Mail Address : Dirección De Correo Electrónico : Courrier Électronique	
Phone Number : Número De Teléfono : Téléphone	Date of Purchase : Fecha de la Compra : Date de l'achat
Where Purchased : Nombre del Almacén donde fue Comprado : Lieu d'achat	
Model Number : Numero del Modelo : No. de modèle Serial Number : Numero de Serie : No. de série	

Registering your purchase enables us to contact you in the unlikely event of a service update or product recall and verifies your ownership in the event of loss. : El registrar su compra nos permite estar en contacto con usted en caso de cualquier evento como el aviso de tiempo de servicio o la revocación del producto y verificación de propiedad en caso de robo o pérdida. : L'enregistrement de votre achat nous permettra de vous contacter dans le cas improbable de modifications des instructions d'entretien ou de rappel du produit et vérifier que vous êtes le propriétaire en cas de vol ou de perte.

Primary use of tool: Professional Homeowner Rental Equip.
 Uso primario de la herramienta: Profesional Dueño de casa Alquiler
 Usage principal: Professionnel Residential Location
 Do you wish to receive periodic ECHO product information and special offers by e-mail? Yes No
 ¿Desea usted recibir información periódica y ofertas especiales por correo electrónico sobre el producto ECHO? Yes No
 Souhaitez-vous recevoir périodiquement de l'information sur les produits ECHO et les offres spéciales par courrier électronique? Oui Non
 Did you visit the ECHO website before purchasing your product?
 Yes No
 Visité usted la página web ECHO antes de comprar su producto?
 Si No
 Avez-vous visité le site d'ECHO avant de procurer votre produit?
 Oui Non

What factor(s) most influenced your purchase?
 Performance Price Dealer
 Reliability Prior Experience Quality
 Friend/Family Brand Warranty
 ¿Qué factor(es) influyó más en su compra?
 Funcionamiento Precio Distribuidor
 Confiabilidad Experiencia Anterior Calidad
 Amigo/Familia Marca Garantía
 Quel facteur (facteurs) vous a influencé le plus?
 Performance Prix Marchand
 Fiabilité Expérience Qualité
 Ami/Famille Marque Garantie

ECHO INC., 400 Oakwood Rd., Lake Zurich, IL 60047
 1.800.432.ECHO WWW.ECHO-USA.COM X7572270206 02-2012



**Limited Warranty Statement for ECHO 56 Volt
Handheld Products and Walk Behind Mowers sold
in USA and Canada**

ECHO Incorporated warrants to the original retail purchaser that this ECHO brand 56 Volt outdoor product is free from defects in material and workmanship and agrees to repair or replace, at ECHO Incorporated's discretion, any defective product free of charge within these time periods from the date of purchase:

- If the product is for homeowner use:
 - Units and Bare Tool – 5 Years
 - Battery or charger – 2 years
- If the product is for commercial use:
 - Units and Bare Tool – 2 years
 - Battery or charger – 2 year
- If the product is for rental use: 90 days for all units, batteries, and chargers.
- Cutting attachments such as, but not limited to, bars, chains, sprockets, blades, tines, belts, PowerBroom™ and nylon trimmer heads for homeowner or non-income producing use will be covered for failures due to defects in material or workmanship for a period of 60 days from original product purchase date and 30 days for commercial / rental use. Any misuse from contact with concrete, rocks, or other structures is not covered by this warranty.

This warranty extends to the original retail purchaser only and commences on the date of the original retail purchase.

Any part of this product found in the reasonable judgment of ECHO Incorporated, to be defective in material or workmanship will be repaired or replaced without charge for parts and labor by an authorized ECHO dealer. Units, repair parts and accessories replaced under this warranty are warranted only for the balance of the original warranty period.

The product, including any defective part, must be returned to an authorized ECHO dealer within the warranty period. The expense of delivering the product to the service center for warranty work and the expense of returning it back to the owner after repair or replacement will be paid by the owner. ECHO Incorporated's, responsibility in respect to claims is limited to making the required repairs or replacements and no claim of breach of warranty shall be cause for cancellation or rescission of the contract of sale of any ECHO brand 56 Volt outdoor product. Proof of purchase will be required by the dealer to substantiate any warranty claim. All warranty work must be performed by an authorized ECHO dealer.

This warranty does not cover any units, battery or charger that has been subject to misuse, neglect, negligence, or accident, or that has been operated in any way contrary to the operating instructions as specified in the Operator's Manual. This warranty does not cover normal deterioration due to the use or exposure, and any repairs made necessary by normal wear, improper

maintenance, improper lubrication, improper storage, dirt, abrasives, impact, moisture, water, rain, snow, rust, corrosion, varnish, or other similar conditions.

This warranty does not cover damage to chargers or batteries by improper charging voltage and batteries that have been exposed to temperatures beyond those specified in the Operator's Manual, batteries that have not been properly charged or batteries that have reached their useful life.

This warranty does not apply to any damage to the product that is the result of improper maintenance or to any product that has been altered or modified. The warranty does not extend to repairs made necessary by normal wear or by the use of parts or accessories which are either incompatible with the ECHO brand 56 Volt outdoor product or adversely affect its operation, performance, or durability. In addition, this warranty does not cover wear to normal items such as, but not limited to:

Wear items – Bump Knobs, Outer Spools, Cutting Lines, Inner Reels, Felt Washers, Hitch Pins, Mulching Blades, Blower Fans, Blower and Vacuum Tubes, Vacuum Bag and Straps, Guide Bars, Saw Chains, Grass Catch Bag, Hedge Trimmer Blades, and Wheels

ECHO Incorporated, reserves the right to change or improve the design of this product without assuming any obligation to modify any product previously manufactured.

All implied warranties are limited in duration to the stated warranty period. Accordingly, any such implied warranties including merchantability, fitness for a particular purpose, or otherwise, are disclaimed in their entirety after the expiration of the appropriate five-year, two-year, one-year, 90-day, 60-day, or 30-day warranty period. ECHO Incorporated's obligation under this warranty is strictly and exclusively limited to the repair or replacement of defective parts. ECHO Incorporated, does not assume or authorize anyone to assume for them any other obligation. Some states do not allow limitations on how long an implied warranty lasts, so the above limitation may not apply to you. ECHO Incorporated, assumes no responsibility for incidental, consequential, or other damages including, but not limited to, expense of returning the product to an authorized dealer for ECHO brand 56 Volt outdoor products and expense of delivering it back to the owner, mechanic's travel time, telephone charges, rental of a like product during the time warranty service is being performed, travel, loss or damage to personal property, loss of revenue, loss of use of the product, loss of time, or inconvenience. Some states do not allow the exclusion or limitation of incidental or consequential damages, so the above limitation or exclusion may not apply to you.

This warranty gives you specific legal rights, and you may also have other rights which vary from state to state.

This warranty applies to all ECHO brand 56 Volt outdoor products manufactured by or for ECHO Incorporated, and sold in the United States and Canada.

To locate your nearest authorized ECHO dealer, visit www.ECHO-usa.com or dial 1-800-432-ECHO (3246).

NOTES

405LMS100001 - 405LMS999999
417LMS100001 - 417LMS999999



ECHO INCORPORATED
400 Oakwood Road
Lake Zurich, IL 60047
www.echo-usa.com