



INSTALLATION MANUAL

MODEL #100947, 100950 – 50 AMP
MODEL #100949, 100952 – 100 AMP
RELIANCE CONTROLS ARL SERIES
AUTOMATIC TRANSFER SWITCH



REGISTER YOUR PRODUCT ONLINE

at championpowerequipment.com

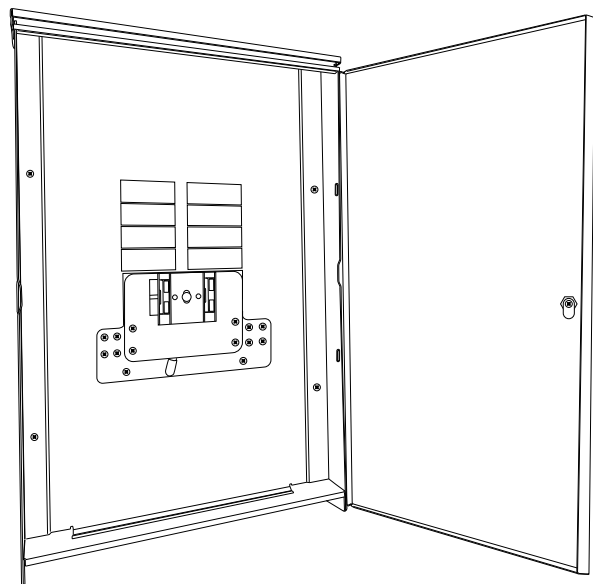
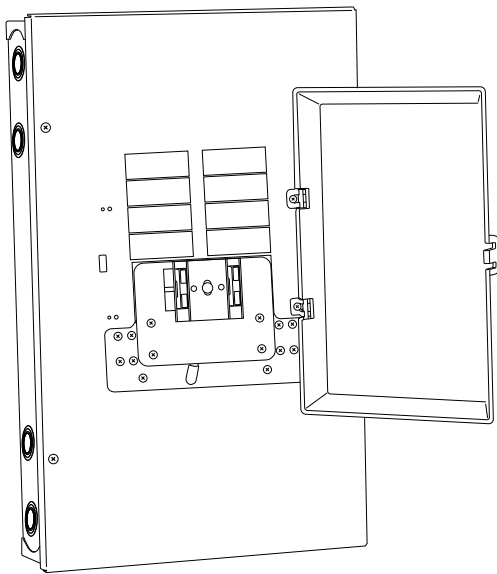

or visit championpowerequipment.com

READ AND SAVE THIS MANUAL. This manual contains important safety precautions which should be read and understood before operating the product. Failure to do so could result in serious injury. This manual should remain with the product. Specifications, descriptions and illustrations in this manual are as accurate as known at the time of publication, but are subject to change without notice.

TABLE OF CONTENTS

Introduction **3**

Safety Definitions **3**

 Safety Symbols 4

 Safety Hangtag 4

Safety Instructions **5**

 ATS Select Switch 6

Controls and Features **9**

 Reliance ARL Series Automatic Transfer Switch Models 9

 Installing the ARL Series Automatic Transfer Switch (ATS) .. 10

 Communication Wiring 10

 Line Voltage Wiring 12

 Circuit Breakers 13

 Select ARL Circuits - Generator 14

 Testing 15

Fuse Information **15**

 Circuit Board – Fuses 15

 Fuse Testing and Replacement 15

 Fuse Replacement 16

Annual Maintenance **17**

Specifications **18**

 Torque 18

Warranty **18**

INTRODUCTION

Congratulations on your purchase of a Champion Power Equipment (CPE) product. When contacting CPE about parts and/or service, you will need to supply the complete model and serial numbers of your product. Transcribe the information found on your product's nameplate label to the table below

CPE TECHNICAL SUPPORT TEAM
1-877-338-0999
MODEL NUMBER
SERIAL NUMBER
DATE OF PURCHASE
PURCHASE LOCATION

SAFETY DEFINITIONS

The purpose of safety symbols is to attract your attention to possible dangers. The safety symbols, and their explanations, deserve your careful attention and understanding. The safety warnings do not by themselves eliminate any danger. The instructions or warnings they give are not substitutes for proper accident prevention measures.

DANGER

DANGER indicates a hazardous situation which, if not avoided, will result in death or serious injury.

WARNING

WARNING indicates a hazardous situation which, if not avoided, could result in death or serious injury.

CAUTION

CAUTION indicates a hazardous situation which, if not avoided, could result in minor or moderate injury.

NOTICE



NOTICE indicates information considered important, but not hazard-related (e.g., messages relating to property damage).

WARNING

Cancer and Reproductive Harm - www.P65Warnings.ca.gov

Safety Symbols

Some of the following symbols may be used on this product. Please study them and learn their meaning. Proper interpretation of these symbols will allow you to more safely operate the product.

SYMBOL	MEANING
	Read Operator's Manual. To reduce the risk of injury, user must read and understand operator's manual before using this product.
	Ground Terminal. Consult an electrician to determine grounding requirements before operation.
	Electric Shock. Improper connections can create an electrocution hazard.

Safety Hangtag

These labels warn you of potential hazards that can cause serious injury. Read them carefully.

If a label comes off or becomes hard to read, contact Technical Support Team for possible replacement.

HANGTAG	DESCRIPTION	PART NUMBER
<p>1</p> 	Alternate Power Source	<p>1681-T-OP (2 per unit) Loose in IM bag</p>

SAFETY INSTRUCTIONS

The Reliance Fast/Tran IS NOT FOR “DO-IT-YOURSELF” INSTALLATION. It must be installed by a qualified electrician thoroughly familiar with all applicable electrical and building codes.

The Reliance Fast/Tran is an automatic transfer switch purpose-designed to provide a safe and simple method of powering a dwelling from a permanently installed backup AC power source. The electrical-over-mechanical transfer switching and interlocking system prevents accidental feedback of backup power onto utility lines.

This manual has been prepared for familiarizing servicing dealer/installer with the design, application, installation and servicing of the equipment.

Read the manual carefully and comply with all instructions.

This manual or a copy of this manual should remain with the switch. Every effort has been taken to make sure that the contents of this manual are accurate and current.

The manufacturer reserves the right to change, alter or otherwise improve this literature and the product at any time without prior notice and without any obligation or liability whatsoever.

The manufacturer cannot anticipate every possible circumstance that might involve a hazard.

The warnings in this manual, tags and decals affixed to the unit are, therefore, not all-inclusive. If using a procedure, work method or operating technique the manufacturer does not specifically recommend follow all codes to ensure safety for personnel.

Many accidents are caused by failing to follow simple and fundamental rules, codes and precautions. Before installing, operating or servicing this equipment, read the SAFETY RULES carefully.

The publications that cover the safe use of ATS and installation are the following NFPA 70, NFPA 70E, UL 1008 and UL 67. It is important to refer to the latest version of any standard/code to ensure correct and current information. All installations must comply with local municipal, state and national codes.

⚠ WARNING

Per OSHA 3120 Publication; “lockout/tagout” refers to specific practices and procedures to safeguard individuals from the unexpected energization or startup of machinery and equipment, or the release of hazardous energy during installation, service or maintenance activities.

⚠ WARNING

Be certain that the power from the utility is turned off and all backup sources are locked out before starting this procedure. Failure to do so could result in serious injury or death. Remember, automatic start generators will start upon loss of utility mains power unless locked in the “off” position. Consult the generator instruction manual for positive “lockout/tagout” procedures.

⚠ CAUTION

Consult with your Local municipal, State and National electrical codes for proper mandatory wiring methods.

Carefully unpack the ATS. Inspect closely for any damage that might have occurred during shipment. Check that all packing material is completely removed from the ATS prior to installation. Handle ATS carefully when installing. Do not drop. Protect the ATS against impacts at all times and against construction grit and metal chips. Never install an ATS that is damaged.

TOOLS REQUIRED	NOT INCLUDED
3/8 in. Torque Wrench	Mounting Hardware
7/32 in. × 3/8 in. Flat Screwdriver Socket	Communication Wire
3/16 in. Flat Screwdriver	Line Voltage Wire
P2 Phillips Screwdriver	Conduit
Pliers	Fittings
Wire stripper	
Hammer	
Twist on wire connectors	

ATS Select Switch

This unit may be wired to several models of ATS (automatic transfer switch). The selector switch is located onboard the generator near the ATS signal wire connector. Select position “1” if you are connecting to an ATS50 or ATS100 and select position “2” if you are connecting to a service entry demand control ATS (up to 200A).

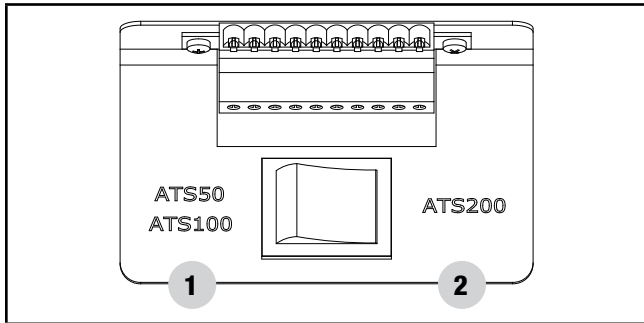

⚠ CAUTION

Failure to set this switch to the matching ATS installed can result in damage to both ATS and HSB.

DIP SWITCHES on the backside of the control, between the 2 rows of pin connectors.

Prior to March 2019, the DIP switches set parameters of the controller for delay sequences. There are 10 DIP switches. These are the designated “ON” or “OFF” position settings for the DIP switches, depending on your setup.

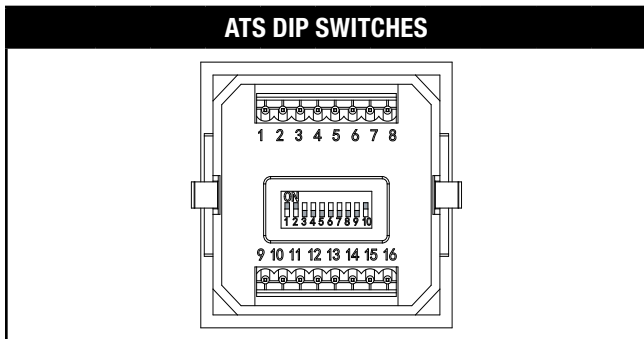

ON	<input checked="" type="checkbox"/>	<input type="checkbox"/>	<input type="checkbox"/>	<input type="checkbox"/>	<input type="checkbox"/>	<input type="checkbox"/>	<input type="checkbox"/>	<input type="checkbox"/>	<input type="checkbox"/>	<input checked="" type="checkbox"/>
OFF	<input type="checkbox"/>	<input type="checkbox"/>	<input checked="" type="checkbox"/>	<input checked="" type="checkbox"/>	<input checked="" type="checkbox"/>	<input checked="" type="checkbox"/>	<input checked="" type="checkbox"/>	<input checked="" type="checkbox"/>	<input checked="" type="checkbox"/>	<input type="checkbox"/>
	1	2	3	4	5	6	7	8	9	10

- 1- ON
- 2- ON for ATS 50/100 - OFF for ATS 200
- 3-9 OFF
- 10-ON-these are factory set delays or activation signals

After March 2019, DIP switches on both the ATS and Engine Control Module have been preset by the factory. No DIP switch adjustments necessary.

Below serial numbers and later are when the DIP switches were preset.

GENERATOR MODEL	STARTING SERIAL NUMBER
100136 - 12.5 kW Generator	18 NOV2301385
100237 - 14 kW	18DEC1900001

Choose your ATS and Generator model to determine how to set your DIP switches:

ATS DIP SWITCHES

50A or 100A ATS:

100947 - ATS Nema 1
 100946 - ATS100 Nema 1
 100950 - ATS50 Nema 3
 100952 - ATS100 Nema 3

ON	1	2	3	4	5	6	7	8	9	10
OFF										

ENGINE CONTROL MODULE DIP SWITCHES

100136 - 12.5 kW Generator
 100237 - 14 kW Generator
 REV E

ON	1	2	3	4	5	6	7	8	9	10
OFF										

ATS DIP SWITCHES

200A ATS:

101283 - ATS 200
 101283 - ATS200

ON	1	2	3	4	5	6	7	8	9	10
OFF										

ENGINE CONTROL MODULE DIP SWITCHES

100136 - 12.5 kW Generator
 100237 - 14 kW Generator
 REV E

ON	1	2	3	4	5	6	7	8	9	10
OFF										

ATS DIP SWITCHES

50A or 100A ATS:

- 100947 - ATS Nema 1
- 100946 - ATS100 Nema 1
- 100950 - ATS50 Nema 3
- 100952 - ATS100 Nema 3

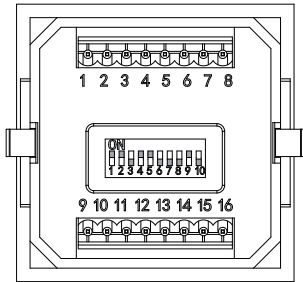

ON										
OFF										
	1	2	3	4	5	6	7	8	9	10

ENGINE CONTROL MODULE DIP SWITCHES

- 100136 - 12.5 kW Generator
- 100237 - 14 kW Generator

REV E

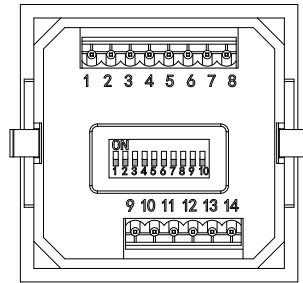

ON										
OFF										
	1	2	3	4	5	6	7	8	9	10

CONTROLS AND FEATURES

Read this installation manual before installing your transfer switch. Familiarize yourself with the location and function of the controls and features. Save this manual for future reference.

Reliance ARL Series Automatic Transfer Switch Models

MODEL NUMBER	ENCLOSURE STYLE	MAXIMUM AMPS	NOMINAL VOLTS
100947 (ARL 0505)	NEMA 1 indoor	50	120/240
100950 (ARL0505R)	NEMA 3R outdoor	50	120/240
100949 (ARL 0909)	NEMA 1 indoor	100	120/240
100952 (ARL0909R)	NEMA 3R outdoor	100	120/240

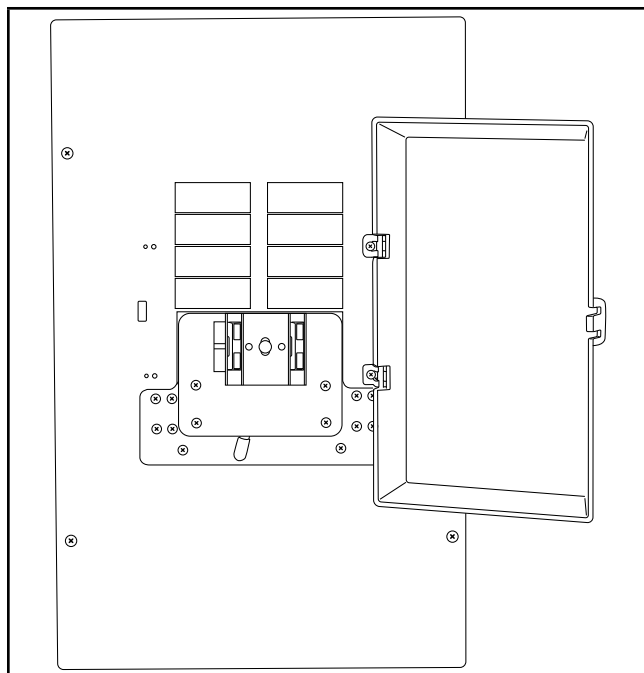

Reliance 100947 used for illustration purposes

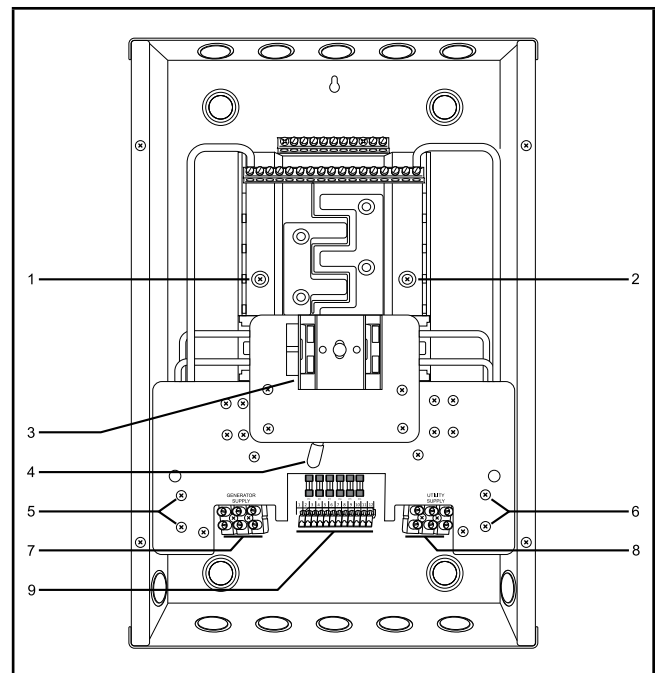

Dead front removed

- | | |
|---|---|
| <ol style="list-style-type: none"> 1. Bus bar mounting screw 2. Bus bar mounting screw 3. Generator side two-pole 50 amp or two-pole 60 amp circuit breaker. 4. Switching mechanism: Generator Supply, Utility Supply, Left to Right 5. Mounting bracket screw (2) | <ol style="list-style-type: none"> 6. Mounting bracket screw (2) 7. Generator input: Neutral – L1 – L2. Designated White, Red, Black 8. Utility input: Neutral – L1 – L2. Designated White, Red, Black 9. Terminal block / Signal wire block (HEADER) numbered 1-12 |
|---|---|

Installing the ARL Series Automatic Transfer Switch (ATS)

The ARL Series is a non-service entrance rated device and is not acceptable for use as service entrance. The NEMA 1 enclosure is only rated for indoor installation, models 100947 and 100949. The NEMA 3R enclosure is weather proof and rated for outdoor or indoor installation, models 100950 and 100952.

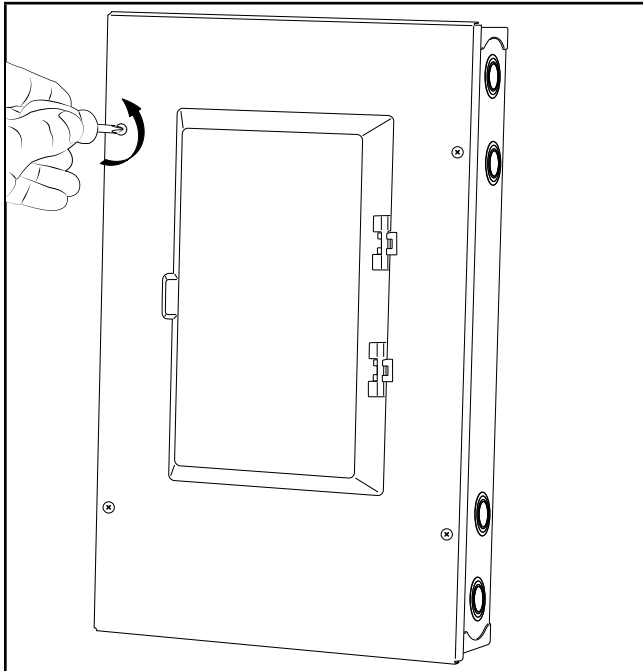

Removing NEMA 1 Dead Front

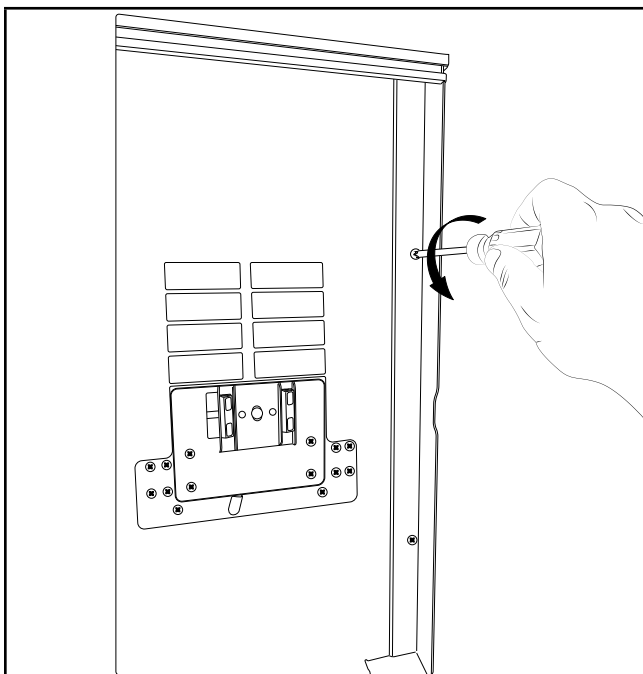

Removing NEMA 3

Communication Wiring

The communication terminal requires 10 wires.

Route a multi-conductor cable (min AWG 18 max AWG 12) from the generator to the 12-position center Terminal Block in the ARL through a smaller knockout. Strip wires 1/4 inch and connect each numbered wire to the terminal block in sequence from left to right starting with 1 in the left-most position.

Note that some of the terminal block positions are deliberately left unused (TB2-4 and TB2-8.)

Each wire is connected by pushing the nylon release lever backwards to open the terminal clamp, inserting the stripped wire into the terminal opening, and releasing the terminal clamp.

CAUTION

Care should be taken not to overstress the nylon release levers.

NOTICE

See the table on page 8 for proper wire routing to both the HSB connector and the ATS connector.

The 10-position communication terminal will connect to your Home Standby. This connector is provided with the Home Standby Generator. Cable is not provided.

CAUTION

Ensure power from the utility is turned off until all communication wiring and line voltage wiring is complete. Failure to comply may result in blown circuit board fuses, which are not covered by warranty.

TERMINAL BLOCK POSITION	FUNCTION	VOLTAGE	COLOR CODE
TB2-1	Switch to Generator Signal	(+24 VDC)	Blue
TB2-2	Switch to Utility Signal	(+24 VDC)	Black/White
TB2-3	Switch to – common return	(0 VDC)	Green
TB2-4	(unused)	(unused)	
TB2-5	Generator Position Micro Switch	Switch closure	Green/Black
TB2-6	Utility Position Micro Switch	Switch closure	Yellow
TB2-7	Position Micro Switch Common	Switch closure	Green
TB2-8	(unused)	(unused)	
TB2-9	Load Bus Line 1 Out	(120 VAC)	Pink
TB2-10	Load Bus Line 2 Out	(120 VAC)	Brown
TB2-11	Utility Line 1 Out	(120 VAC)	Purple
TB2-12	Utility Line 2 Out	(120 VAC)	Orange

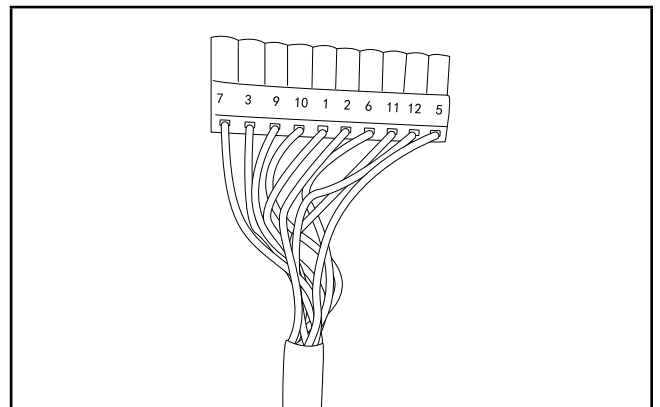
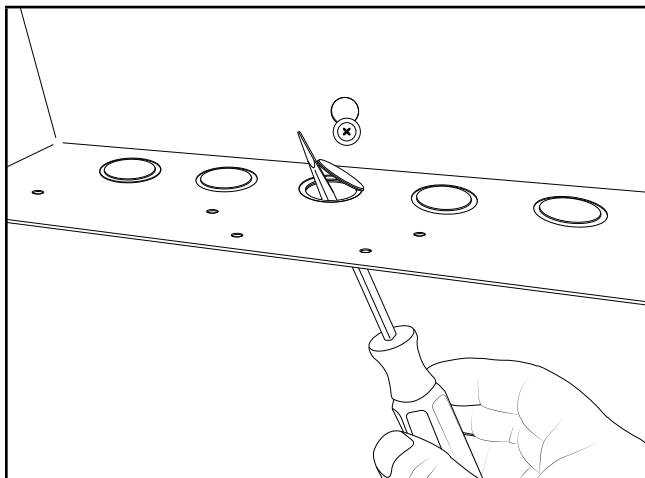

10-Position Home Standby Connector (with wire termination)

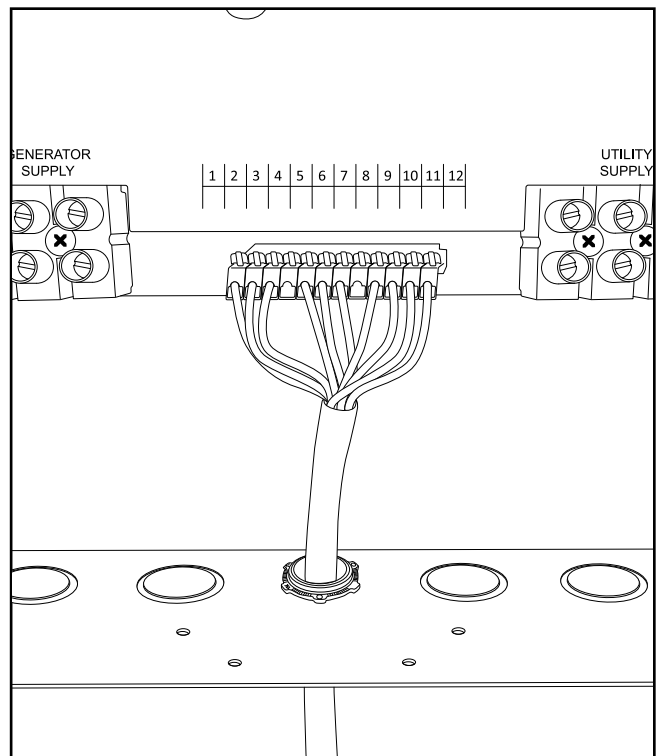
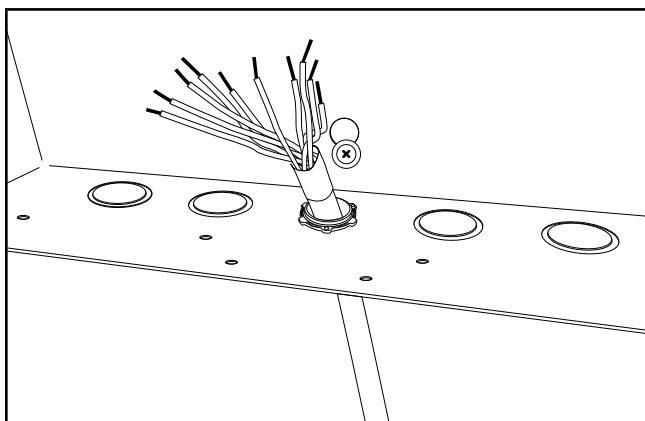

Terminal Block Connection

Line Voltage Wiring

⚠ WARNING

Be certain that the power from the utility is turned off and all backup sources are locked out before starting this procedure. Failure to do so could result in serious injury or death. Remember, automatic start generators will start upon loss of utility mains power unless locked in the "off" position.

Consult the generator operator manual section to locate the ATS CONTROL and ENGINE CONTROL module to make sure both switches are in the OFF position.

⚠ CAUTION

Consult all local and National electrical codes for proper wiring methods for all wiring.

Install a 50-amp double pole circuit breaker in the load center (home distribution panel) as a feeder for the ATS for 50-amp rated ARL.

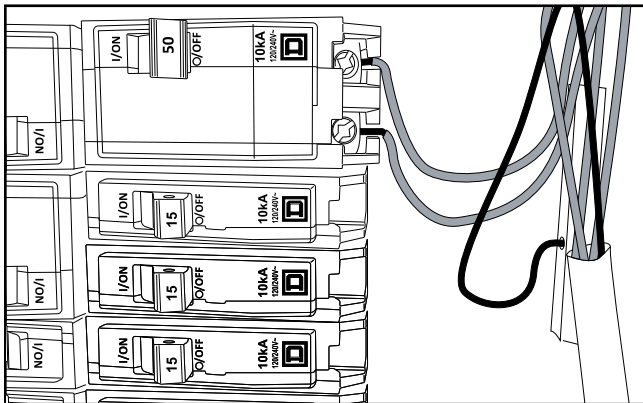

Install a 100-amp double pole circuit breaker in the load center (home distribution panel) as a feeder for the ATS for 100-amp rated ARL.

Install, route and connect (Use Cu wire, min 75°C) Black L1, and Red L2 wire appropriate for 50-amp or 100-amp size (dependent on ARL) between the double-pole feeder breaker in the load center and the similarly-colored terminals on Utility Supply terminal block in the ATS through a larger knockout. Strip wires 1/2 inch.

Use Cu wire, min 75°C

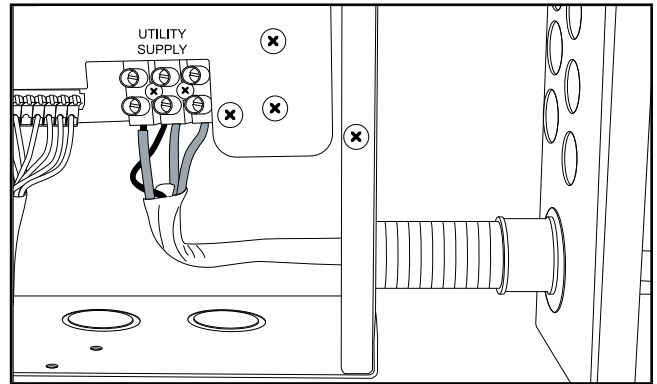

Route and connect wire of the same AWG between the neutral bar in the main panel and the White terminal on Utility Supply terminal block in the ATS. Route and connect a ground wire between the ground busses in the two panels.

Torque all line voltage connections to 25 in-lbs.

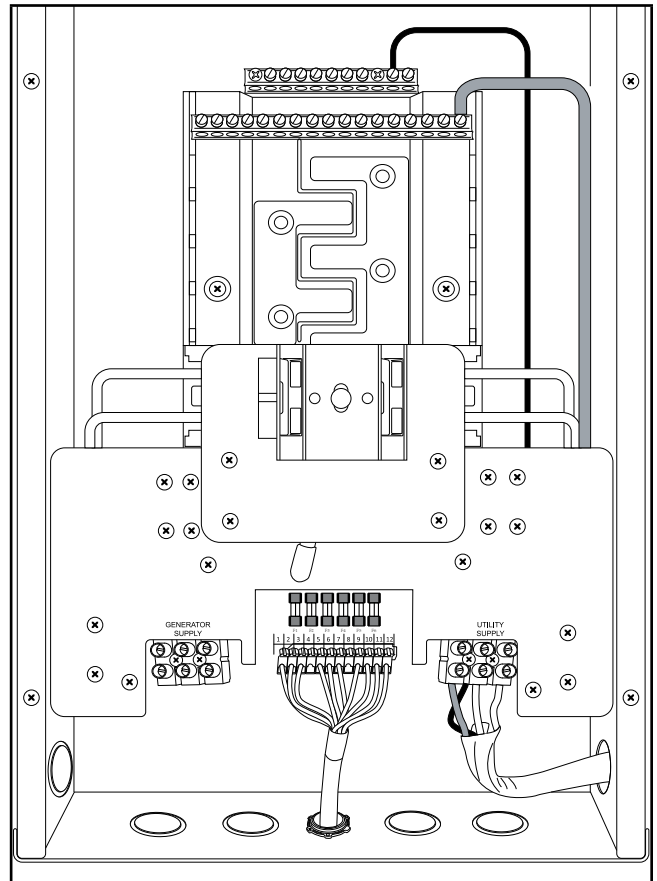

Circuit Breakers

The ARL will accommodate tandem circuit breakers, but only in the four circuit breaker spaces closest to the transfer mechanism (The ones with the slotted bus stabs).

The upper four locations are suitable only for full-size breakers.

Recommended tandem breakers are the same as full size breakers listed on inside of entry door.

For example: If Square - D / Schneider makes a tandem breaker in the "HOM" series it will fit in the slotted bus stabs of the ARL.

This transfer panel is UL listed for the following branch circuit breakers.

Siemens	QP, QT, BQ, QPH, BQH, BL
Eaton/Cutler-Hammer/ Westinghouse	BD, BR, BQ, GFC
Murray	MP
Square-D/Schneider	HOM
GE	THQL

Circuit Breaker Options

The 100947 (ARL0505) has spaces for eight 1-inch interchangeable breakers, four of which can be tandems.

The 100949 (ARL0909) has spaces for twelve 1-inch interchangeable breakers, four of which can be tandems.

UL limits the number of tandem breakers that can be used in a single breaker cabinet to limit the heat generated.

Install, route and connect (Use Cu or Al wire, min 75°C) Black L1, and Red L2 wire of the appropriate size for generator output from the power output terminals on generator through a larger knockout to the Generator Supply terminal block in the ARL. Strip wires 1/2 inch.

Route and connect the neutral wire to the White Generator Supply terminal block in the ARL. Route and connect the ground wire to the ground buss bar in the ARL.

NOTICE

If Load center circuit breakers are compatible with ARL branch circuit, the circuit breakers may be moved from the Load center to the ARL. Make certain the openings in the dead front of the Load center, created by removing those breakers, are fitted with appropriate filler plugs.

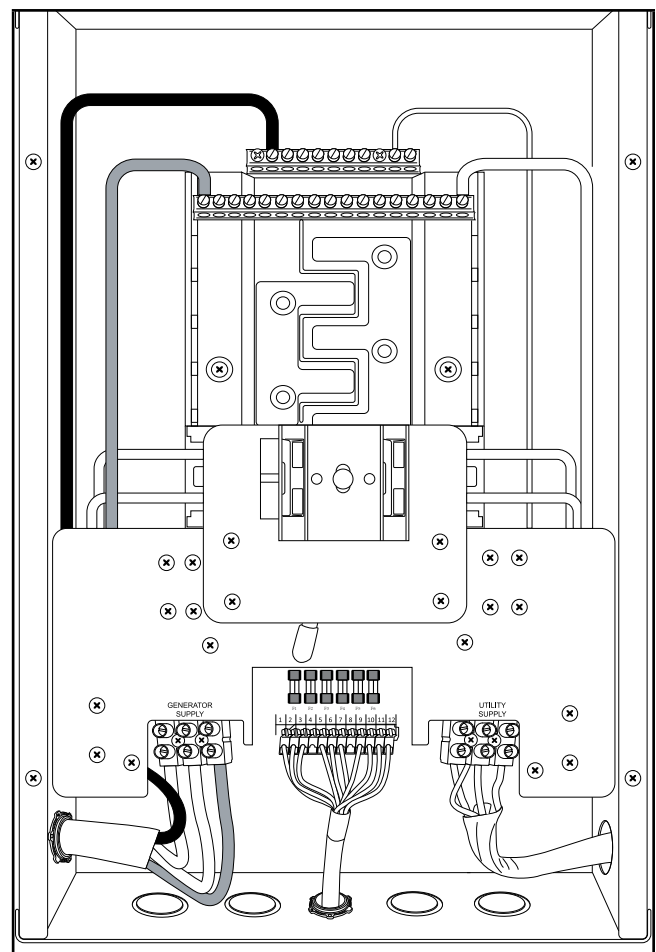
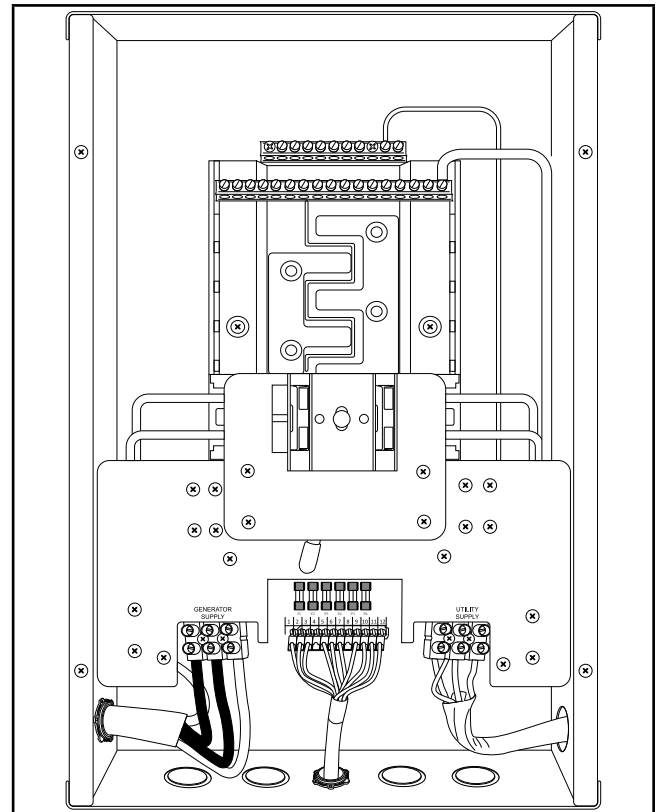

Torque all line voltage connections. Specifications page 15.

Select ARL Circuits - Generator

Select the circuits to be powered by the generator. Remove the selected breakers from the main panel.

If the removed breakers are of an accepting type, install them in the ARL. If not, discard them and buy suitable breakers of the correct ampacity.

Extend the branch circuit conductors from the main panel into the ARL by using suitable gauge and color of approved building wire and appropriate wire connectors.

The ARL is UL listed for several 1-inch interchangeable breakers (see label on the inside cover of the ARL) or, page 10, of the **Circuit Breakers** section.

Install only circuit breakers that are compatible with ARL branch circuit.

Pull wire to new circuit breakers in ARL branch circuit from circuit breaker in Load center.

Use Cu or Al wire, min 75°C

Connect each branch circuit conductor (wire) to its appropriate branch circuit breaker from the Load center.

Repeat for each of the selected circuits.

The branch conductors must be connected to the same ampacity breakers as they were when they were in the Load center.

Make certain that the total amp capacity of the selected circuits does not exceed the maximum capacity of the generator.

Balance the load on the ARL by dividing the branch circuit breakers evenly between the two sides as shown in Figure 1.

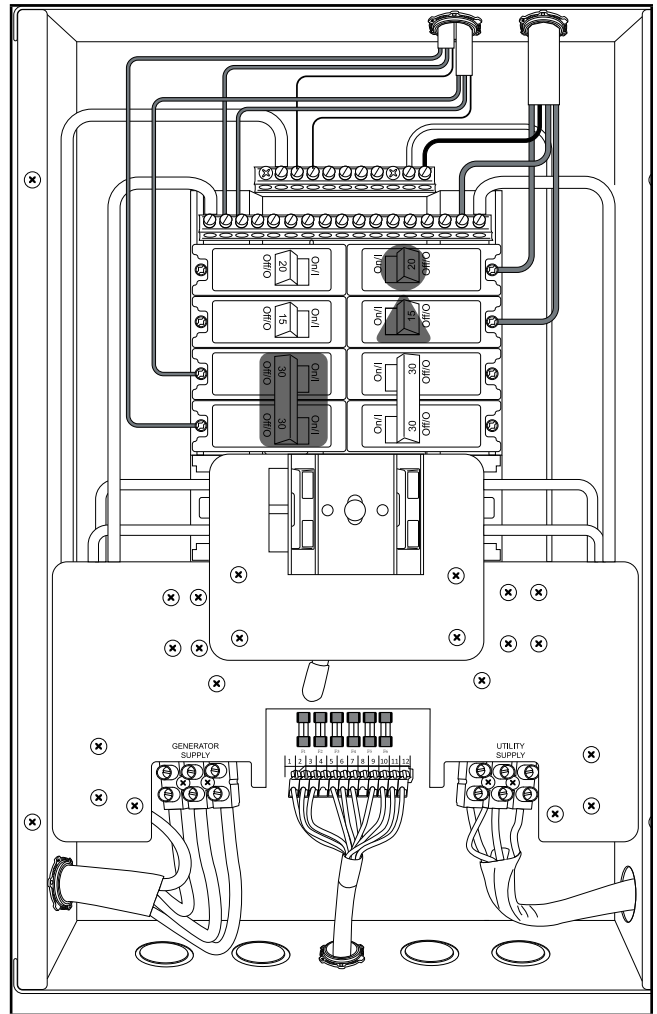
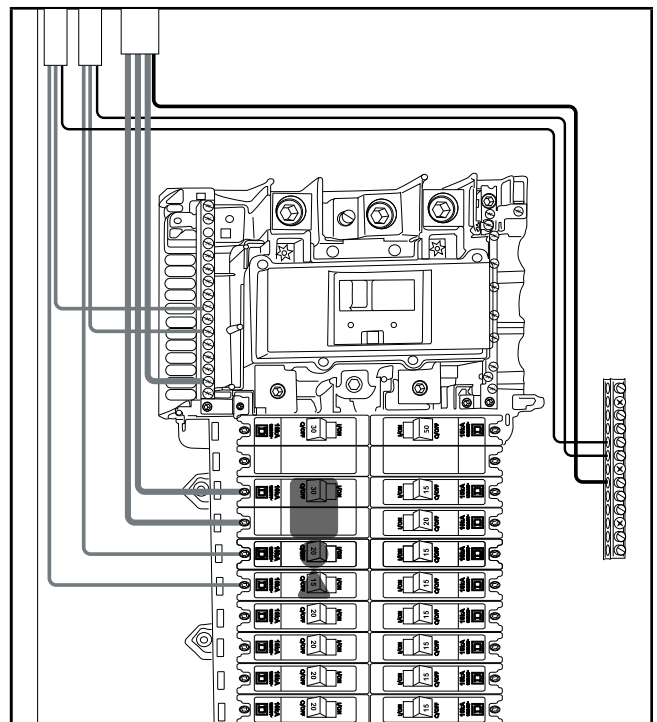

Figure 1 – ARL Branch Circuit Breaker



Load Center Circuit Breakers

Testing

To assure the ARL is functioning properly

1. Turn OFF all of the distribution breakers in the ATS.
2. Manually switch the ATS to the utility position by moving the manual lever to the position marked Utility.
3. Turn ON the feeder breaker in the main panel board
4. Turn ON all distribution breakers and verify that all connected circuits are functioning properly.
5. Remove the lockout apparatus and arm the HSB generator.

Your Fast/Tran ARL Series automatic transfer switch (ATS) is now fully functional. To test its performance, simply disable utility mains power.

Your generator should start and your ATS will automatically switch to the "GENERATOR SUPPLY" source to power its loads. When utility mains power is re-enabled, your ATS will automatically switch back to "UTILITY SUPPLY" source.

Your generator will cool down, and turn off and then be placed back into standby ready position.

FUSE INFORMATION

Circuit Board – Fuses

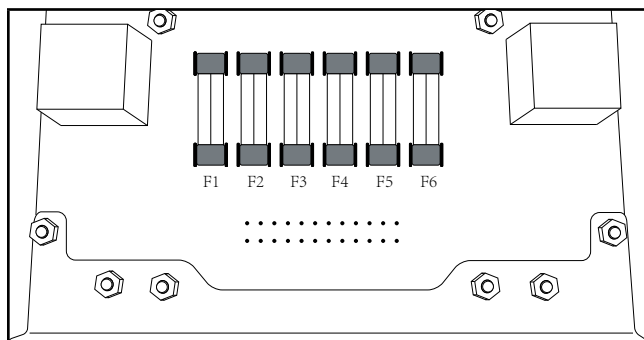

⚠ WARNING

The power from "BOTH" the UTILITY power source and the HSB "MUST" be turned "OFF" before attempting to identify or replace any fuses. Failure to do so could result in serious injury or death.

On the front side of the circuit board are six (6) fuses. Refer to the fuse table on the ATS. Should any of these fuses blow, the generator controller needs to be inspected and serviced by a qualified technician. Once the cause of the blown fuse is resolved, the fuse will need to be replaced. See fuse chart in transfer switch for replacement fuse values.

To access the fuses on the rear of the circuit board, remove the 4 screws (parts 5 and 6, figure 2) from the mounting bracket, and remove the two screws from the bus bar (parts 1 and 2, figure 2). To access these screws, the branch circuit breakers will need to be pulled off (removed) from the bus bar first. The entire bus bar and mechanism assembly now can tilt away from the cabinet (toward you), providing access to the rear of the circuit board and the fuses.

Fuse identification, left to right:

6. F1 Utility Solenoid
7. F2 Utility L2 Out
8. F3 Utility L1 Out
9. F4 Load Bus L2 Out
10. F5 Load Bus L1 Out
11. F6 Generator Solenoid

Fuse Testing and Replacement

Test Fuses F2 and F3:

Disconnect the wires that are connected to terminals 9 and 10 on the 12-position terminal block.

With utility power on, verify the fact that all circuits connected to the ATS are energized. Connect an AC voltmeter between terminals 9 and 10. If the voltmeter reads approximately 240 VAC, fuses F2 and F3 are functional. If not inspect F2 and F3. Replace one, or both fuse.

Remove the voltmeter and reconnect the wires that were installed in terminals 9 and 10, in the correct order. Test F4 and F5.

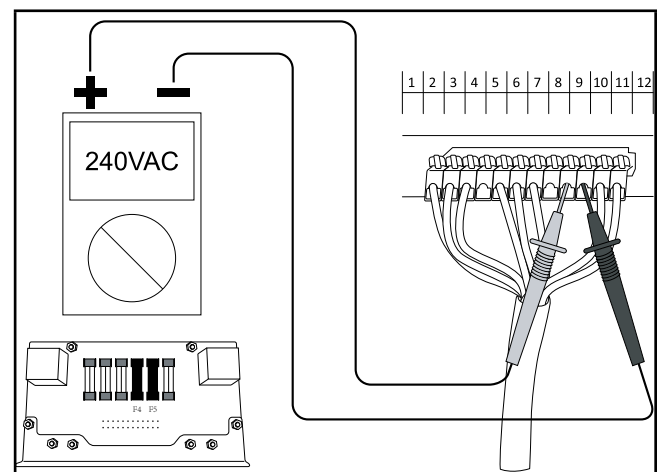

Test Fuses F4 and F5:

Disconnect the wires that are connected to terminals 11 and 12 on the 12-position terminal block. With utility power on, verify the fact that all circuits connected to the ATS are energized.

Connect an AC voltmeter between terminals 11 and 12.

If the voltmeter reads approximately 240 VAC, fuses F4 and F5 are functional. If not inspect F4 and F5. Replace one, or both fuse.

Remove the voltmeter and reconnect the wires that were installed in terminals 11 and 12, in the correct order. Test F1.

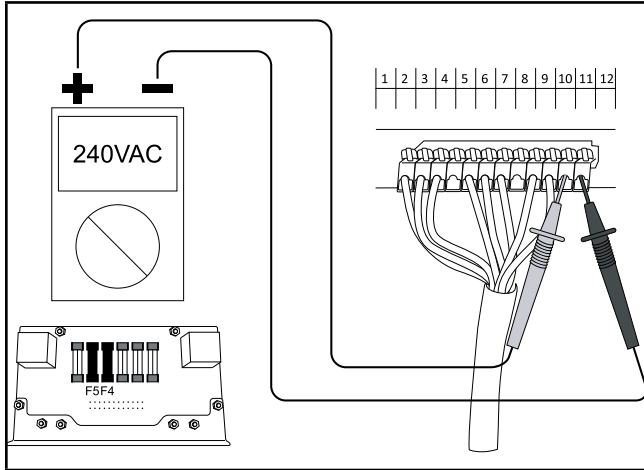

Test Fuse F1:

Disconnect the wires that are connected to terminals 1, 2, and 3 on the 12-position terminal block. With utility power on, verify the fact that all circuits connected to the ARL are energized.

Connect the negative lead of a 24VDC power supply to terminal 3.

FOR NO MORE THAN 1 SECOND, press the positive lead of the 24VDC power supply to terminal 1.

If the solenoid clicks and the mechanism transfers, fuse F1 is functional. If not replace fuse.

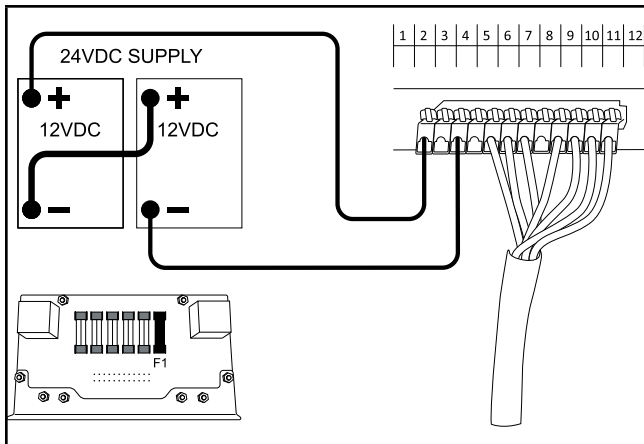

Disconnect the 24VDC power supply and reconnect the wires that were installed in terminals 1, 2, and 3, in the correct order.

Test F6.

Test Fuse F6:

Disconnect the wires that are connected to terminals 1, 2, and 3 on the 12-position terminal block. With generator power on, verify the fact that all circuits connected to the ARL are energized.

Connect the negative lead of a 24VDC power supply to terminal 3.

FOR NO MORE THAN 1 SECOND, press the positive lead of the 24VDC power supply to terminal 2.

If the solenoid clicks and the mechanism transfers, fuse F6 is functional. If not replace fuse.

Disconnect the 24VDC power supply and reconnect the wires that were installed in terminals 1, 2, and 3, in the correct order.

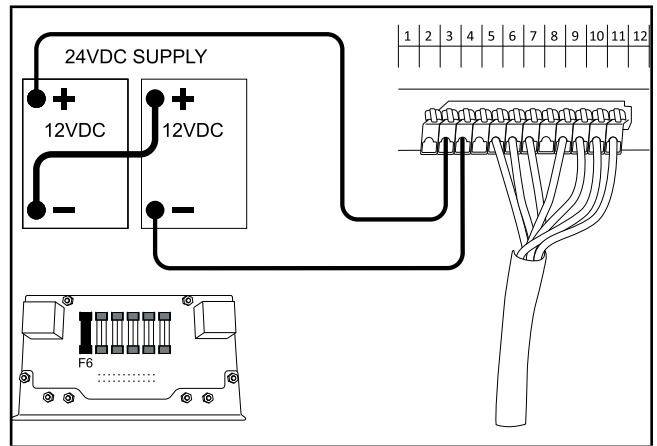

Fuse Replacement

CAUTION

ATS cannot be live or installed to perform this procedure. Be sure all power is disconnected before continuing. Failure to do so can result in serious injury or death.

1. Locate and remove the ATS cover plate by removing the mounting screws (1-4) shown below.

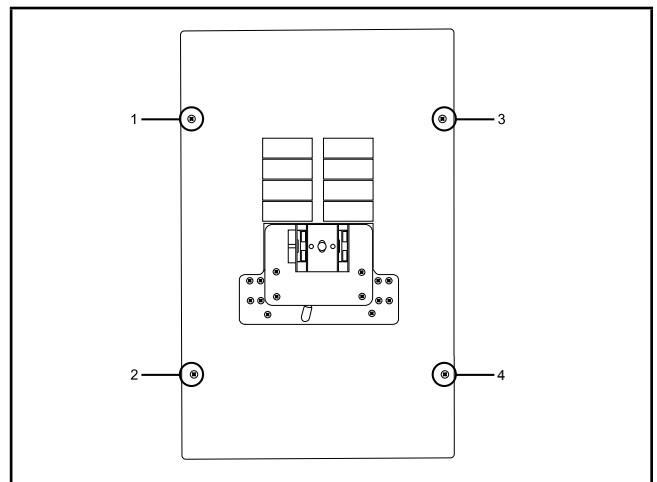

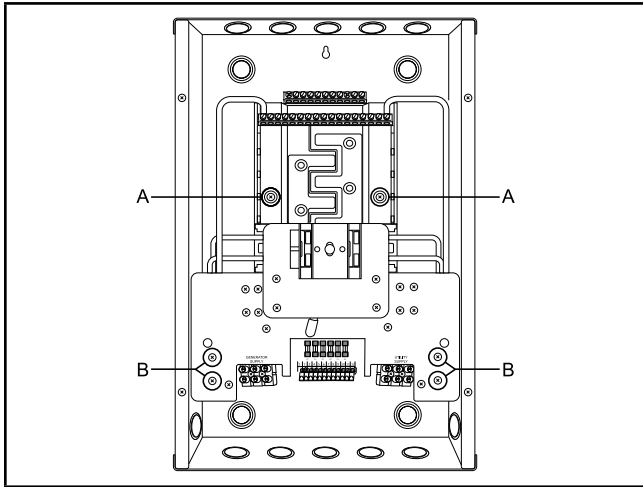

2. Replace fuse as necessary.

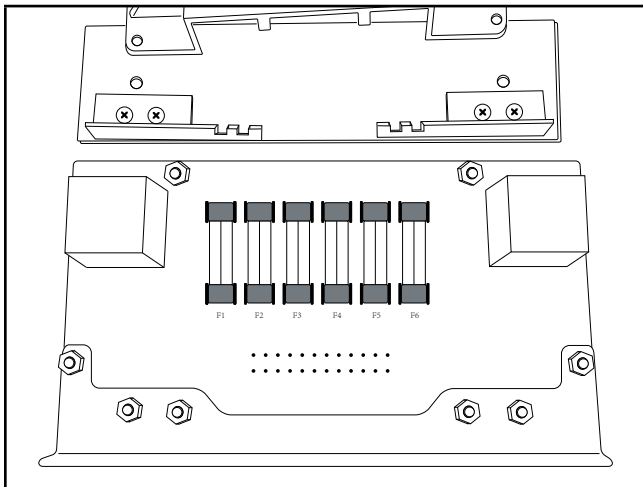

If you have any questions, please call our Toll Free number at 1-877-338-0999. Thank you.

ANNUAL MAINTENANCE

The ARL should be maintained yearly.

Visually inspect the unit to assure that there are no broken objects or loose wires in the cabinet.

SPECIFICATIONS

MODEL NUMBER	ENCLOSURE STYLE	MAXIMUM AMPS	NOMINAL VOLTS	BREAKER SPACES
100947 (ARL 0505)	NEMA 1 indoor	50	120/240	8
100950 (ARL0505R)	NEMA 3R outdoor	50	120/240	8
100949 (ARL 0909)	NEMA 1 indoor	100	120/240	12
100952 (ARL0909R)	NEMA 3R outdoor	100	120/240	12

Torque

LOCATION	WIRE	TORQUE
Neutral bar	14-10 AWG	20 in. lb.
Neutral bar	8 AWG	25 in. lb.
Ground bar		20 in. lb.
3 Position terminal strip	14-6 AWG	16 in. lb. (MAX)

WARRANTY

Each Reliance transfer switch or accessory is guaranteed against mechanical or electrical failure due to manufacturing defects for a period of 24 months following shipment from the factory. The manufacturer’s responsibility during this warranty period is limited to repair or replacement, free of charge, or products proving to be defective under normal use or service when returned to the factory, transportation charges prepaid. Guarantee is void on products that have been subjected to improper installation, misuse, alteration, abuse or unauthorized repair. The manufacturer makes no warranty with respect to the fitness of any goods for a users particular application and assumes no responsibility for proper selection and installation of its products. This warranty is in lieu of all other warranties, expressed or implied, and limits the manufacturer’s liability for damages to the cost of the product. This warranty gives you specific legal rights, and you may have other rights, which vary from state to state.