

OPERATOR'S MANUAL

MODEL #201246

120W SOLAR PANEL



REGISTER YOUR PRODUCT ONLINE

at championpowerequipment.com



 **1-877-338-0999**

or visit championpowerequipment.com

SAVE THESE INSTRUCTIONS. This manual contains important safety precautions which should be read and understood before operating the product. Failure to do so could result in serious injury. This manual should remain with the product.

Specifications, descriptions and illustrations in this manual are as accurate as known at the time of publication, but are subject to change without notice.

TABLE OF CONTENTS

Introduction	3	Operation	6
Safety Definitions	3	Maintenance	7
Important Safety Instructions	4	Cleaning the Solar Panel	7
Features	5	Frequently Asked Questions (FAQ)	8
Solar Panel	5	Specifications	9
Parts Included	5		

INTRODUCTION

Congratulations on your purchase of a Champion Power Equipment (CPE) product. CPE designs, builds, and supports all of our products to strict specifications and guidelines. With proper product knowledge, safe use, and regular maintenance, this product should bring years of satisfying service.

Every effort has been made to ensure the accuracy and completeness of the information in this manual at the time of publication, and we reserve the right to change, alter and/or improve the product and this document at any time without prior notice.

CPE highly values how our products are designed, manufactured, operated, and serviced as well as providing safety to the operator and those around the generator. Therefore, it is IMPORTANT to review this product manual and other product materials thoroughly and be fully aware and knowledgeable of the assembly, operation, dangers and maintenance of the product before use. Fully familiarize yourself, and make sure others who plan on operating the product fully familiarize themselves too, with the proper safety and operation procedures before each use. Please always exercise common sense and always err on the side of caution when operating the product to ensure no accident, property damage, or injury occurs. We want you to continue to use and be satisfied with your CPE product for years to come.

When contacting CPE about parts and/or service, you will need to supply the complete model and serial numbers of your product. Transcribe the information found on your product's nameplate label to the table below

CPE TECHNICAL SUPPORT TEAM
1-877-338-0999
MODEL NUMBER
201246
SERIAL NUMBER
DATE OF PURCHASE
PURCHASE LOCATION

SAFETY DEFINITIONS

The purpose of safety symbols is to attract your attention to possible dangers. The safety symbols, and their explanations, deserve your careful attention and understanding. The safety warnings do not by themselves eliminate any danger. The instructions or warnings they give are not substitutes for proper accident prevention measures.

⚠ DANGER

DANGER indicates a hazardous situation which, if not avoided, will result in death or serious injury.

⚠ WARNING

WARNING indicates a hazardous situation which, if not avoided, could result in death or serious injury.

⚠ CAUTION

CAUTION indicates a hazardous situation which, if not avoided, could result in minor or moderate injury.

🗨 NOTICE

NOTICE indicates information considered important, but not hazard-related (e.g., messages relating to property damage).

IMPORTANT SAFETY INSTRUCTIONS

⚠ WARNING

Cancer and Reproductive Harm – www.P65Warnings.ca.gov

⚠ WARNING

Read all safety warnings and all instructions. Failure to follow the warnings and instruction may result in electric shock, fire and cause serious injury. Save all warnings and instruction.

⚠ DANGER

Solar panel generates powerful voltage.

Keep your solar panel in a dry, well-ventilated area when not in use.

Do not use or store solar panels near open flames or flammable materials.

Do not operate the solar panel with damaged output cable or connectors.

Do not allow children or unqualified persons to operate or service the solar panel.

Do not bend the solar panel.

Do not step on or place objects on top of the solar panel.

The output circuit of the solar panels must be correctly connected to the device.

Do not reverse or short-circuit the positive and negative poles. Ensure that there is no gap between the insulated connections. If there is a gap, sparks or electrical shocks will occur.

Do not submerge the solar panel in water.

Do not leave or submerge the connector ends in water.

Do not allow corrosive chemicals or conductive fluids, such as seawater, industrial chemicals, bleach or bleach containing products to come in contact with the solar panel.

⚠ WARNING

To avoid fire or electrical shock hazard, observe all ratings on the solar panel and accessory products you intend to use.

⚠ WARNING

Do not use solar panel for medical life support uses.

In case of emergency, call 911 immediately.

NEVER use this product to power life support devices or life support appliances.

Inform your electricity provider immediately if you or anyone in your household depends on electrical equipment to live.

Inform your electrical provider immediately if a loss of power would cause you or anyone in your household to experience a medical emergency.

⚠ WARNING

Solar panel produces heat. Skin burns can occur on contact.

Do not touch hot surfaces.

Allow equipment to cool before touching.

⚠ WARNING

Exceeding the input specifications of the device being charged by the solar panel can damage the devices connected to it.

DO NOT use or connect solar panels in any way that exceeds the input specifications of the devices used with the solar panels.

DO NOT use or connect solar panels in any way that exceeds the current and voltage limits of the extension cable's wire gauge (AWG). Always consult NEC 310-16 Allowable Ampacities of Insulated Conductors chart.

DO NOT tamper or modify the solar panel in any way.

⚠ WARNING

Improper treatment or use of the solar panel can damage it, shorten its life or void the warranty.

Use the solar panel only for intended uses.

DO NOT expose solar panel to excessive moisture, dust, or dirt.

If connected devices overheat, turn them off and disconnect them from the solar panel.

DO NOT use the solar panel if:

- Electrical output is lost
- Equipment sparks, smokes or emits flames

FEATURES

Read this operator’s manual before operating your solar panel. Familiarize yourself with the location and function of the features. Save this manual for future reference.

Solar Panel

Front View

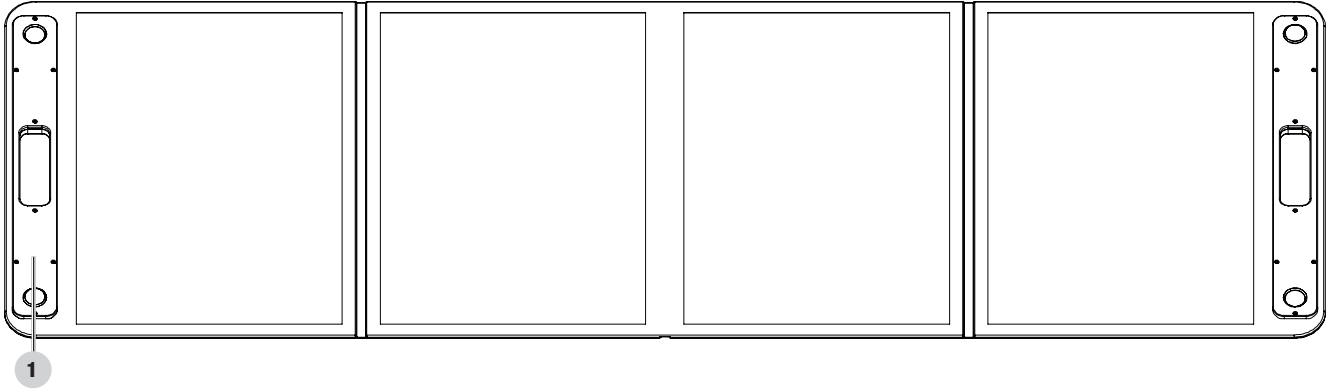

Back View

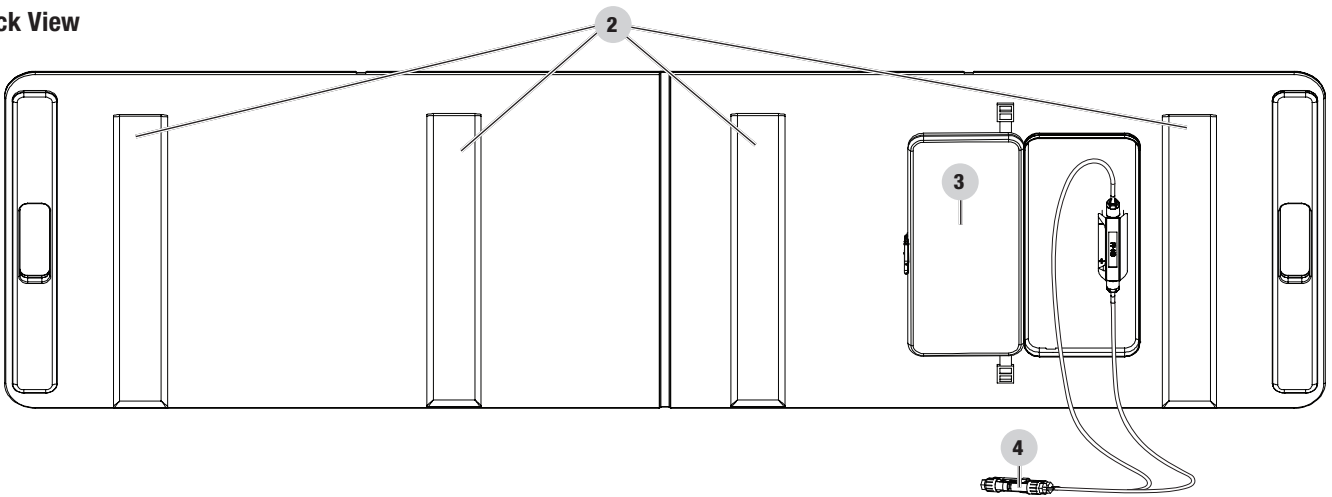

1. **Carrying Handle** – Used to lift or carry the unit.
2. **Kickstand** – Used to support the solar panel.
3. **Cable Storage Pocket** – Used to store the cables and Operator’s Manual.
4. **MC4 Connectors** – Used to connect to desired device or extension cable.

Parts Included

Accessories

- 10 ft. (3 m) MC4 Extension Cable (14AWG) 1

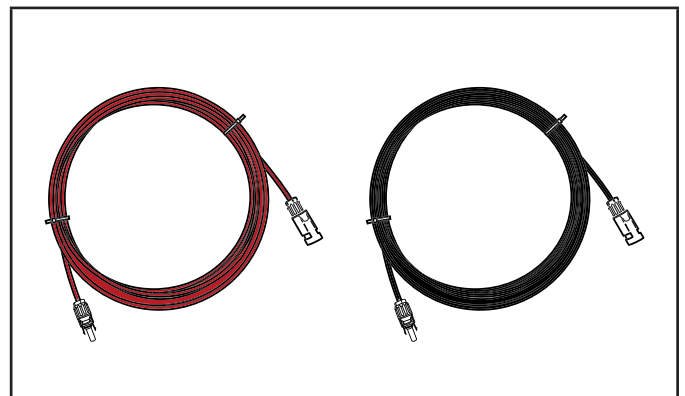

OPERATION

⚠ WARNING

Max open circuit voltage should never exceed the max input voltage of the device or power station. Use a multimeter, or consult a qualified technician, to check the solar panel's voltage only when the solar panel is disconnected and during peak sunlight to get correct maximum readings. Voltages may be higher in colder temperatures or when the solar panel is cold.

Check your device's operator's manual for correct configuration when connecting more than one solar panel. Generally, it is not recommended to connect multiple solar panels when charging small devices and some Power Stations as the voltage and/or current may exceed the maximum input specifications.

DO NOT use or connect solar panels in any way that exceeds the current and voltage limits of the extension cable's wire gauge (AWG). Always consult NEC 310-16 Allowable Ampacities of Insulated Conductors chart. This is especially important when connecting solar panels in parallel.

1. Unbuckle the storage straps.

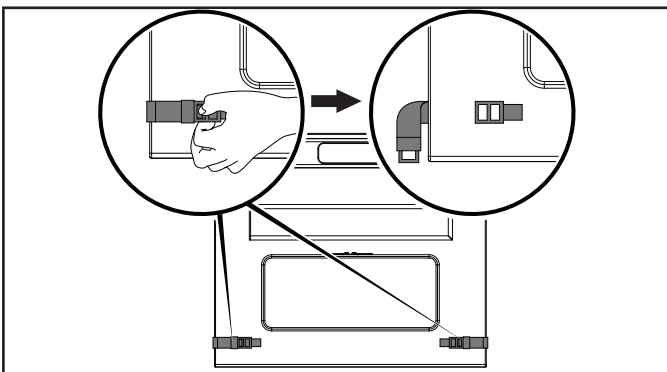

2. Partially unfold the solar panel so it can stand on its own.

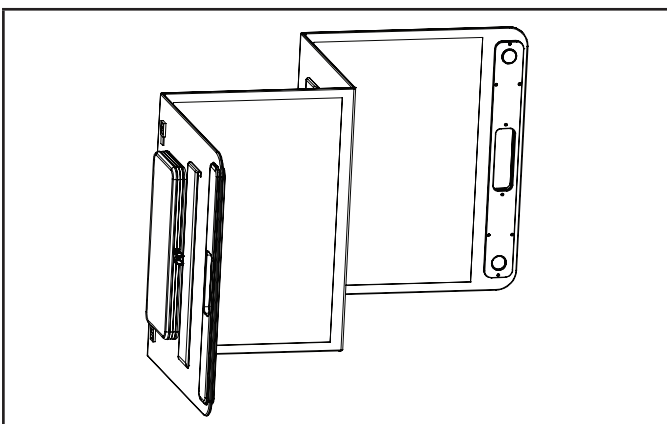

3. Extend each kick stand one by one and fully unfold the solar panel.

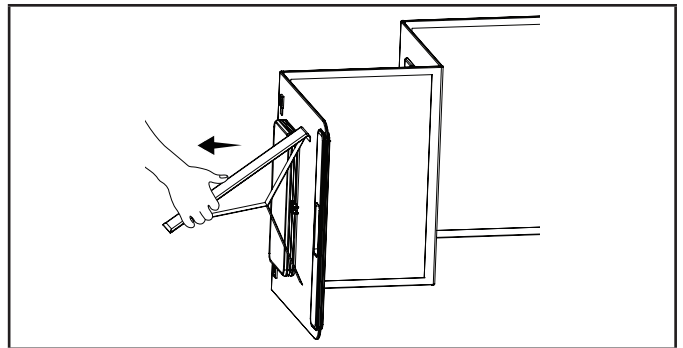

4. Adjust the solar panel to face the sun as much as possible, avoiding any shaded spots, trees, or obstructions in the sun's path throughout the day. Frequent and minor adjustments can show a significant increase in power.

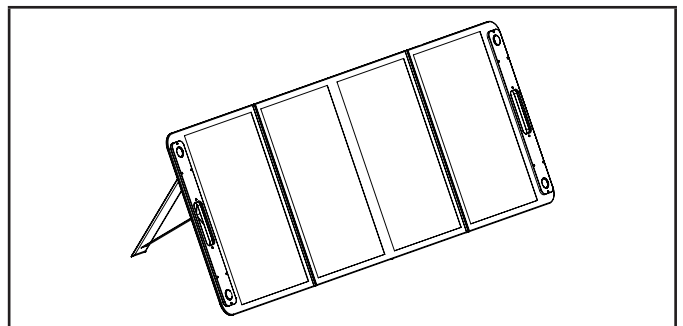

5. Remove the cables from the storage pocket. Connect the solar panel to the device or power station. Ensure the connectors are pressed together tightly and no gap exists. Keep connections away from puddles and standing water.

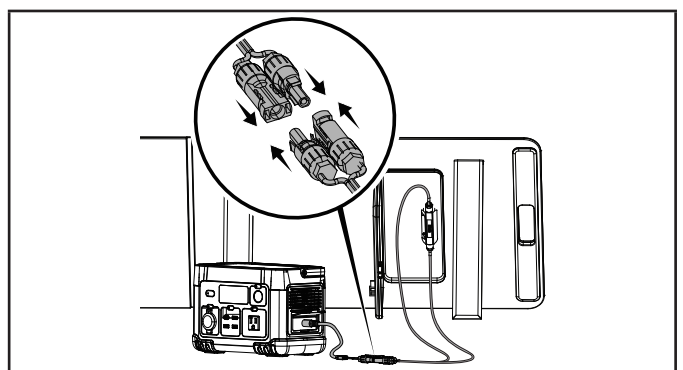

6. Periodically adjust the solar panel to ensure it is facing the sun at the optimal angle.

MAINTENANCE

Cleaning the Solar Panel

CAUTION

Do not scratch the solar panel with abrasive cleaning pads or brushes. Only use damp cloth to clean. Even minor scratches can diminish performance.

Gently wipe the surface of the solar panel with a damp cloth to remove any dust and debris. Remove animal droppings and stuck on objects as soon as possible.

It is important to clean the solar panel regularly as even dust you may not see can lower the efficiency of the solar panel.

FREQUENTLY ASKED QUESTIONS (FAQ)

Question	Answer
Can I use this panel with any Power Station or Solar Generator?	This solar panel will work with any Champion Power Station and most other power stations and solar generators that have MC4 connections. Third Party adapters can be purchased to fit other connectors.
Why can't I achieve the rated wattage?	<p>Due to thermal and power losses when converting the sun's energy to usable power and DC to DC conversion in the power station, no solar panel can achieve its full rated wattage.</p> <p>Always consider the weather conditions including cloudiness, temperature, and angle to the sun. Ensure your solar panel is clean and free of dust and within allowable range of your power stations input specs.</p>
Can I run this panel in series or parallel with multiple panels?	<p>Yes, always check the resulting voltage and current and your devices operator's manual. Running in series will increase the voltage and running in parallel will increase the current. Do not exceed the input specifications of the device being charged.</p> <p>Especially when connecting solar panels in parallel with extension or other third party cables, always consult NEC Ampacity Chart to check current does not exceed the limit of the wire gauge (AWG) and length used.</p>
Do I need a charge controller?	Not for any Champion products and most other Power Stations. Consult your product's manufacturer directly for other products.
Is the solar panel waterproof?	The solar panel is rated IP65 meaning it does protect from water, light rain, and dust intrusion. However, to increase the life of your solar panel, it is best to store indoors when not in use and avoid rain and avoid getting soaked. Never submerge in water.

SPECIFICATIONS

Model	201246
Peak Power	120W
Solar Cell	Monocrystalline
Solar Cell Lamination	ETFE
Cell Efficiency	22%
Voltage at Max Power (Vmp)	18.4V
Current at Max Power (Imp)	6.5A
Open Circuit Voltage (Voc)	21.8A
Short Circuit Current (Isc)	6.9A
Operating Temperature (°F/°C)	14 to 149/-10 to 65
Optimal Operating Temperature (°F/°C)	77/25
Weight	13.2 lb. (6 kg)
Unfolded	
Length	67.1 in. (170.4 cm)
Width	21.1 in. (53.5 cm)
Height	1.0 in. (2.5 cm)
Folded	
Length	18.1 in. (46 cm)
Width	21.1 in. (53.5 cm)
Height	1.4 in. (3.6 cm)

WARRANTY*

CHAMPION POWER EQUIPMENT
2 YEAR LIMITED WARRANTY

Warranty Qualifications

To register your product for warranty and FREE lifetime call center technical support please visit:

<https://www.championpowerequipment.com/register>

To complete registration you will need to include a copy of the purchase receipt as proof of original purchase. Proof of purchase is required for warranty service. Please register within ten (10) days from date of purchase.

Repair/Replacement Warranty

CPE warrants to the original purchaser that the mechanical and electrical components will be free of defects in material and workmanship for a period of two years (parts and labor) from the original date of purchase and 180 days (parts and labor) for commercial and industrial use. Transportation charges on product submitted for repair or replacement under this warranty are the sole responsibility of the purchaser. This warranty only applies to the original purchaser and is not transferable.

Do Not Return The Unit To The Place Of Purchase

Contact CPE's Technical Service and CPE will troubleshoot any issue via phone or e-mail. If the problem is not corrected by this method, CPE will, at its option, authorize evaluation, repair or replacement of the defective part or component at a CPE Service Center. CPE will provide you with a case number for warranty service. Please keep it for future reference. Repairs or replacements without prior authorization, or at an unauthorized repair facility, will not be covered by this warranty.

Warranty Exclusions

This warranty does not cover the following repairs and equipment:

Normal Wear

Products with mechanical and electrical components need periodic parts and service to perform well. This warranty does not cover repair when normal use has exhausted the life of a part or the equipment as a whole.

Installation, Use and Maintenance

This warranty will not apply to parts and/or labor if the product is deemed to have been misused, neglected, involved in an accident, abused, loaded beyond the product's limits, modified, installed improperly or connected incorrectly to any electrical component. Normal maintenance is not covered by this warranty and is not required to be performed at a facility or by a person authorized by CPE.

Other Exclusions

This warranty excludes:

- Cosmetic defects such as paint, decals, etc.
- Wear items such as filter elements, o-rings, etc.
- Accessory parts such as storage covers.
- Failures due to acts of God and other force majeure events beyond the manufacturer's control.
- Problems caused by parts that are not original Champion Power Equipment parts.

Limits of Implied Warranty and Consequential Damage

Champion Power Equipment disclaims any obligation to cover any loss of time, use of this product, freight, or any incidental or consequential claim by anyone from using this product. THIS WARRANTY IS IN LIEU OF ALL OTHER WARRANTIES, EXPRESS OR IMPLIED, INCLUDING WARRANTIES OF MERCHANTABILITY OR FITNESS FOR A PARTICULAR PURPOSE.

A unit provided as an exchange will be subject to the warranty of the original unit. The length of the warranty governing the exchanged unit will remain calculated by reference to the purchase date of the original unit.

This warranty gives you certain legal rights which may change from state to state or province to province. Your state or province may also have other rights you may be entitled to that are not listed within this warranty.

Contact Information

Address

Champion Power Equipment, Inc.
6370 S Pioneer Way, Unit 101
Las Vegas, NV 89113 USA
www.championpowerequipment.com

Customer Service

Toll Free: 1-877-338-0999
info@championpowerequipment.com
Fax no.: 1-562-236-9429

Technical Service

Toll Free: 1-877-338-0999
tech@championpowerequipment.com
24/7 Tech Support: 1-562-204-1188