

SPLIT-TYPE, HEAT PUMP AIR CONDITIONERS

2022

R410A

SERVICE MANUAL

Series PEAD **Ceiling Concealed**

Model name
<Indoor unit>

PEAD-A09AA8
PEAD-A12AA8
PEAD-A15AA8
PEAD-A18AA8
PEAD-A24AA8
PEAD-A30AA8
PEAD-A36AA8
PEAD-A42AA8

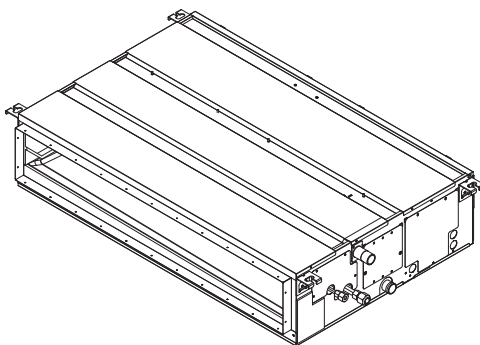

INDOOR UNIT

2nd edition

Mr. SLIM™

CONTENTS

1. SAFETY PRECAUTION	3
2. PART NAMES AND FUNCTIONS	5
3. SPECIFICATION	6
4. FAN PERFORMANCE AND CORRECTED AIR FLOW	10
5. SOUND PRESSURE LEVELS	17
6. OUTLINES & DIMENSIONS	23
7. WIRING DIAGRAM	25
8. REFRIGERANT SYSTEM DIAGRAM	26
9. HEATER CONTROL	27
10. HUMIDIFIER CONTROL	32
11. ERV (ENERGY RECOVERY VENTILATION) CONTROL	33
12. TROUBLESHOOTING	34
13. DISASSEMBLY PROCEDURE	47

1. SAFETY PRECAUTION

1-1. ALWAYS OBSERVE FOR SAFETY

Before obtaining access to terminal, all supply circuits must be disconnected.

1-2. CAUTIONS RELATED TO NEW REFRIGERANT

Caution for units utilising refrigerant R410A

Use new refrigerant pipes.

In case of using the existing pipes for R22, be careful with the followings.

- For A36 and A42, be sure to perform replacement operation before test run.
- Change flare nut to the one provided with this product. Use a newly flared pipe.
- Avoid using thin pipes.

Make sure that the inside and outside of refrigerant piping is clean and it has no contamination such as sulfur hazardous for use, oxides, dirt, shaving particles, etc. In addition, use pipes with specified thickness.

Contamination inside refrigerant piping can cause deterioration of refrigerant oil etc.

Store the piping to be used indoors during installation and both ends of the piping sealed until just before brazing. (Leave elbow joints, etc. in their packaging.)

If dirt, dust or moisture enters into refrigerant cycle, that can cause deterioration of refrigerant oil or malfunction of compressor.

Use ester oil, ether oil or alkylbenzene oil (small amount) as the refrigerant oil applied to flares and flange connections.

If large amount of mineral oil enters, that can cause deterioration of refrigerant oil etc.

Charge refrigerant from liquid phase of gas cylinder.

If the refrigerant is charged from gas phase, composition change may occur in refrigerant and the efficiency will be lowered.

Do not use refrigerant other than R410A.

If other refrigerant (R22 etc.) is used, chlorine in refrigerant can cause deterioration of refrigerant oil etc.

Use a vacuum pump with a reverse flow check valve.

Vacuum pump oil may flow back into refrigerant cycle and that can cause deterioration of refrigerant oil etc.

Use the following tools specifically designed for use with R410A refrigerant.

The following tools are necessary to use R410A refrigerant.

Tools for R410A	
Gauge manifold	Flare tool
Charge hose	Size adjustment gauge
Gas leak detector	Vacuum pump adaptor
Torque wrench	Electronic refrigerant charging scale

Handle tools with care.

If dirt, dust or moisture enters into refrigerant cycle, that can cause deterioration of refrigerant oil or malfunction of compressor.

Do not use a charging cylinder.

If a charging cylinder is used, the composition of refrigerant will change and the efficiency will be lowered.

Ventilate the room if refrigerant leaks during operation. If refrigerant comes into contact with a flame, poisonous gases will be released.

<1> Cautions for service

- (1) Perform service after recovering the refrigerant left in unit completely.
- (2) Do not release refrigerant in the air.
- (3) After completing service, charge the cycle with specified amount of refrigerant.
- (4) When performing service, install a filter drier simultaneously.
Be sure to use a filter drier for new refrigerant.

<2> Additional refrigerant charge

When charging directly from cylinder

- Check that cylinder for R410A on the market is syphon type.
- Charging should be performed with the cylinder of syphon stood vertically. (Refrigerant is charged from liquid phase.)

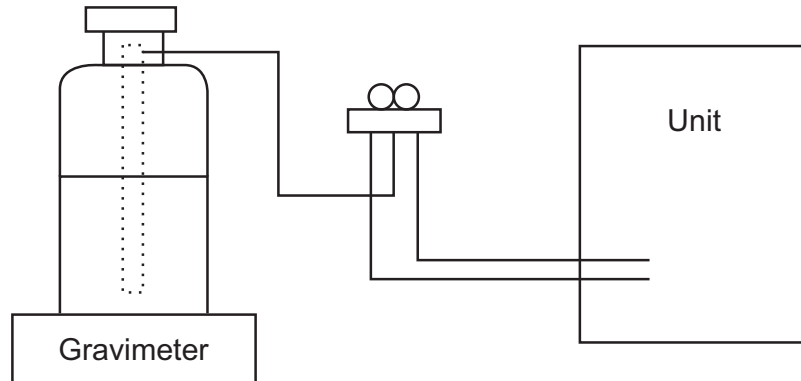

<3> Service tools

Use the below service tools as exclusive tools for R410A refrigerant.

No.	Tool name	Specifications
1	Gauge manifold	<ul style="list-style-type: none"> • Only for R410A • Use the existing fitting specifications. (UNF1/2) • Use high-tension side pressure of 5.3MPa·G or over.
2	Charge hose	<ul style="list-style-type: none"> • Only for R410A • Use pressure performance of 5.09MPa·G or over.
3	Electronic scale	—
4	Gas leak detector	• Use the detector for R134a, R407C or R410A.
5	Adaptor for reverse flow check	• Attach on vacuum pump.
6	Refrigerant charge base	—
7	Refrigerant cylinder	<ul style="list-style-type: none"> • Only for R410A • Top of cylinder (Pink) • Cylinder with syphon
8	Refrigerant recovery equipment	—

1-3. CAUTIONS RELATED TO HEATER

- Exercise caution when using any auxiliary heat source and follow all third party manufacturer instructions and safety guidelines for installation and usage.
- Any auxiliary heat source connected to this unit via the CN24 connection must have an independent temperature control mechanism. Failure to install and maintain such temperature control mechanism may void the warranty for this unit.
- Mitsubishi Electric shall not bear any warranty obligation or other liability for any damage or loss in connection with such third party auxiliary heaters.

2. PART NAMES AND FUNCTIONS

• Indoor Unit

Air intake (sucks the air inside the room into the unit)

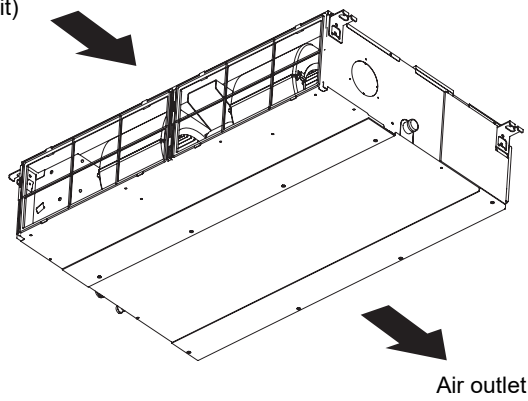

In case of rear inlet

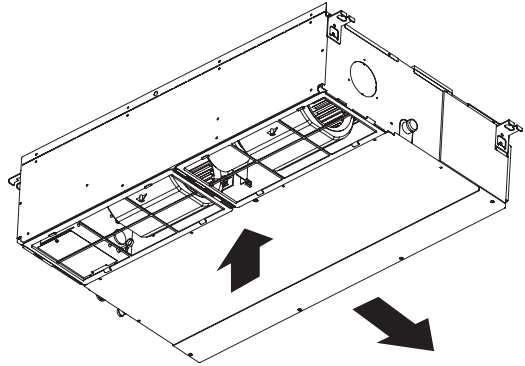

In case of bottom inlet

3. SPECIFICATION

INDOOR UNIT	Service Ref.		PEAD-A09AA8	
	Power supply (phase, cycle, voltage)		1 phase, 60Hz, 208/230V	
	Max. Fuse Size	A	15	
	Min. Circuit Ampacity	A	2.18	
	External finish		Galvanized sheets	
	Heat exchanger		Plate fin coil	
	Fan	Fan (drive) × No.		Sirocco fan × 2
		Fan motor output	kW	0.121
		Fan motor	F.L.A	1.74
		Airflow (Low-Mid-High)	m ³ /min (CFM)	8.0-9.0-10.0 (282-318-353)
		External static pressure	Pa (in.WG)	35-50-70-100-150 (0.14-0.20-0.28-0.40-0.60)
	Operation control & Thermostat		Remote controller & built-in	
	Sound pressure level (Low-Mid-High)	35Pa (0.14 in.WG)	dB (A)	24-26-28
		50Pa (0.20 in.WG)		26-28-31
		70Pa (0.28 in.WG)		27-30-33
		100Pa (0.40 in.WG)		30-33-36
		150Pa (0.60 in.WG)		33-36-39
Field drain pipe O.D		mm (in.)	32 (1-1/4)	
Dimensions	W	mm (in.)	900 (35-7/16)	
	D	mm (in.)	732 (28-7/8)	
	H	mm (in.)	250 (9-7/8)	
Weight		kg (lbs)	26 (58)	

INDOOR UNIT	Service Ref.		PEAD-A12AA8	
	Power supply (phase, cycle, voltage)		1 phase, 60Hz, 208/230V	
	Max. Fuse Size	A	15	
	Min. Circuit Ampacity	A	2.23	
	External finish		Galvanized sheets	
	Heat exchanger		Plate fin coil	
	Fan	Fan (drive) × No.		Sirocco fan × 2
		Fan motor output	kW	0.121
		Fan motor	F.L.A	1.78
		Airflow (Low-Mid-High)	m ³ /min (CFM)	10.0-12.0-14.0 (353-424-494)
		External static pressure	Pa (in.WG)	35-50-70-100-150 (0.14-0.20-0.28-0.40-0.60)
	Operation control & Thermostat		Remote controller & built-in	
	Sound pressure level (Low-Mid-High)	35Pa (0.14 in.WG)	dB (A)	25-29-33
		50Pa (0.20 in.WG)		27-31-34
		70Pa (0.28 in.WG)		28-32-36
		100Pa (0.40 in.WG)		31-35-39
		150Pa (0.60 in.WG)		34-39-43
Field drain pipe O.D		mm (in.)	32 (1-1/4)	
Dimensions	W	mm (in.)	900 (35-7/16)	
	D	mm (in.)	732 (28-7/8)	
	H	mm (in.)	250 (9-7/8)	
Weight		kg (lbs)	26 (58)	

INDOOR UNIT	Service Ref.		PEAD-A15AA8	
	Power supply (phase, cycle, voltage)		1 phase, 60Hz, 208/230V	
	Max. Fuse Size	A	15	
	Min. Circuit Ampacity	A	2.44	
	External finish		Galvanized sheets	
	Heat exchanger		Plate fin coil	
	Fan	Fan (drive) × No.		Sirocco fan × 2
		Fan motor output	kW	0.121
		Fan motor	F.L.A	1.95
		Airflow (Low-Mid-High)	m ³ /min (CFM)	12.0-14.5-17.0 (424-512-600)
		External static pressure	Pa (in.WG)	35-50-70-100-150 (0.14-0.20-0.28-0.40-0.60)
	Operation control & Thermostat		Remote controller & built-in	
	Sound pressure level (Low-Mid-High)	35Pa (0.14 in.WG)	dB (A)	28-33-36
		50Pa (0.20 in.WG)		29-34-37
		70Pa (0.28 in.WG)		31-35-39
		100Pa (0.40 in.WG)		33-37-41
		150Pa (0.60 in.WG)		35-40-44
	Field drain pipe O.D		mm (in.)	32 (1-1/4)
Dimensions	W	mm (in.)	900 (35-7/16)	
	D	mm (in.)	732 (28-7/8)	
	H	mm (in.)	250 (9-7/8)	
Weight		kg (lbs)	27 (60)	

INDOOR UNIT	Service Ref.		PEAD-A18AA8	
	Power supply (phase, cycle, voltage)		1 phase, 60Hz, 208/230V	
	Max. Fuse Size	A	15	
	Min. Circuit Ampacity	A	2.44	
	External finish		Galvanized sheets	
	Heat exchanger		Plate fin coil	
	Fan	Fan (drive) × No.		Sirocco fan × 2
		Fan motor output	kW	0.121
		Fan motor	F.L.A	1.95
		Airflow (Low-Mid-High)	m ³ /min (CFM)	12.0-14.5-17.0 (424-512-600)
		External static pressure	Pa (in.WG)	35-50-70-100-150 (0.14-0.20-0.28-0.40-0.60)
	Operation control & Thermostat		Remote controller & built-in	
	Sound pressure level (Low-Mid-High)	35Pa (0.14 in.WG)	dB (A)	28-33-36
		50Pa (0.20 in.WG)		29-34-37
		70Pa (0.28 in.WG)		31-35-39
		100Pa (0.40 in.WG)		33-37-41
		150Pa (0.60 in.WG)		35-40-44
	Field drain pipe O.D		mm (in.)	32 (1-1/4)
Dimensions	W	mm (in.)	900 (35-7/16)	
	D	mm (in.)	732 (28-7/8)	
	H	mm (in.)	250 (9-7/8)	
Weight		kg (lbs)	27 (60)	

INDOOR UNIT	Service Ref.		PEAD-A24AA8	
	Power supply (phase, cycle, voltage)		1 phase, 60Hz, 208/230V	
	Max. Fuse Size	A	15	
	Min. Circuit Ampacity	A	2.28	
	External finish		Galvanized sheets	
	Heat exchanger		Plate fin coil	
	Fan	Fan (drive) × No.		Sirocco fan × 2
		Fan motor output	kW	0.121
		Fan motor	F.L.A	1.82
		Airflow (Low-Mid-High)	m ³ /min (CFM)	14.5-18.0-21.0 (512-636-742)
		External static pressure	Pa (in.WG)	35-50-70-100-150 (0.14-0.20-0.28-0.40-0.60)
	Operation control & Thermostat		Remote controller & built-in	
	Sound pressure level (Low-Mid-High)	35Pa (0.14 in.WG)	dB (A)	27-31-35
		50Pa (0.20 in.WG)		28-32-36
		70Pa (0.28 in.WG)		28-33-37
		100Pa (0.40 in.WG)		30-35-39
		150Pa (0.60 in.WG)		33-38-42
Field drain pipe O.D		mm (in.)	32 (1-1/4)	
Dimensions	W	mm (in.)	1100 (43-5/16)	
	D	mm (in.)	732 (28-7/8)	
	H	mm (in.)	250 (9-7/8)	
Weight		kg (lbs)	30 (67)	

INDOOR UNIT	Service Ref.		PEAD-A30AA8	
	Power supply (phase, cycle, voltage)		1 phase, 60Hz, 208/230V	
	Max. Fuse Size	A	15	
	Min. Circuit Ampacity	A	2.30	
	External finish		Galvanized sheets	
	Heat exchanger		Plate fin coil	
	Fan	Fan (drive) × No.		Sirocco fan × 2
		Fan motor output	kW	0.121
		Fan motor	F.L.A	1.84
		Airflow (Low-Mid-High)	m ³ /min (CFM)	17.5-21.0-25.0 (618-742-883)
		External static pressure	Pa (in.WG)	35-50-70-100-150 (0.14-0.20-0.28-0.40-0.60)
	Operation control & Thermostat		Remote controller & built-in	
	Sound pressure level (Low-Mid-High)	35Pa (0.14 in.WG)	dB (A)	30-34-38
		50Pa (0.20 in.WG)		30-34-39
		70Pa (0.28 in.WG)		31-35-39
		100Pa (0.40 in.WG)		33-37-41
		150Pa (0.60 in.WG)		35-39-43
Field drain pipe O.D		mm (in.)	32 (1-1/4)	
Dimensions	W	mm (in.)	1100 (43-5/16)	
	D	mm (in.)	732 (28-7/8)	
	H	mm (in.)	250 (9-7/8)	
Weight		kg (lbs)	30 (67)	

INDOOR UNIT	Service Ref.		PEAD-A36AA8	
	Power supply (phase, cycle, voltage)		1 phase, 60Hz, 208/230V	
	Max. Fuse Size	A	15	
	Min. Circuit Ampacity	A	3.25	
	External finish		Galvanized sheets	
	Heat exchanger		Plate fin coil	
	Fan	Fan (drive) × No.		Sirocco fan × 3
		Fan motor output	kW	0.300
		Fan motor	F.L.A	2.60
		Airflow (Low-Mid-High)	m ³ /min (CFM)	24.0-29.0-34.0 (847-1024-1201)
		External static pressure	Pa (in.WG)	35-50-70-100-150 (0.14-0.20-0.28-0.40-0.60)
	Operation control & Thermostat		Remote controller & built-in	
	Sound pressure level (Low-Mid-High)	35Pa (0.14 in.WG)	dB (A)	34-38-41
		50Pa (0.20 in.WG)		35-39-42
		70Pa (0.28 in.WG)		36-40-43
		100Pa (0.40 in.WG)		37-41-45
		150Pa (0.60 in.WG)		39-43-47
Field drain pipe O.D		mm (in.)	32 (1-1/4)	
Dimensions	W	mm (in.)	1400 (55-1/8)	
	D	mm (in.)	732 (28-7/8)	
	H	mm (in.)	250 (9-7/8)	
Weight		kg (lbs)	38 (84)	

INDOOR UNIT	Service Ref.		PEAD-A42AA8	
	Power supply (phase, cycle, voltage)		1 phase, 60Hz, 208/230V	
	Max. Fuse Size	A	15	
	Min. Circuit Ampacity	A	4.00	
	External finish		Galvanized sheets	
	Heat exchanger		Plate fin coil	
	Fan	Fan (drive) × No.		Sirocco fan × 3
		Fan motor output	kW	0.300
		Fan motor	F.L.A	3.20
		Airflow (Low-Mid-High)	m ³ /min (CFM)	29.5-35.5-42.0 (1042-1254-1483)
		External static pressure	Pa (in.WG)	35-50-70-100-150 (0.14-0.20-0.28-0.40-0.60)
	Operation control & Thermostat		Remote controller & built-in	
	Sound pressure level (Low-Mid-High)	35Pa (0.14 in.WG)	dB (A)	37-41-45
		50Pa (0.20 in.WG)		37-41-45
		70Pa (0.28 in.WG)		38-42-46
		100Pa (0.40 in.WG)		39-43-47
		150Pa (0.60 in.WG)		41-45-49
Field drain pipe O.D		mm (in.)	32 (1-1/4)	
Dimensions	W	mm (in.)	1400 (55-1/8)	
	D	mm (in.)	732 (28-7/8)	
	H	mm (in.)	250 (9-7/8)	
Weight		kg (lbs)	39 (86)	

4. FAN PERFORMANCE AND CORRECTED AIR FLOW

PEAD-A09AA8

(External static pressure 35Pa) 208-230V 60Hz

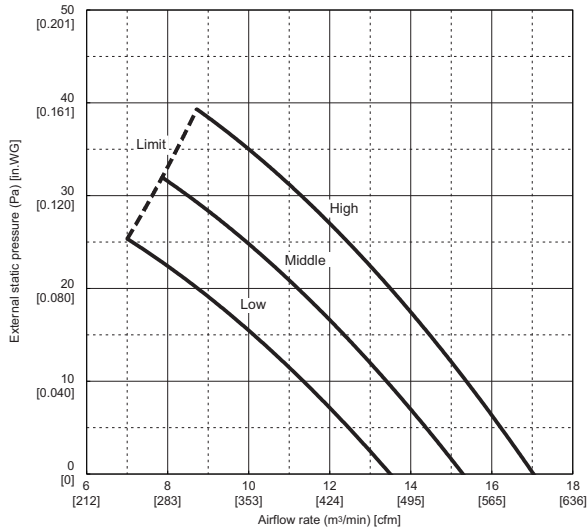

PEAD-A09AA8

(External static pressure 100Pa) 208-230V 60Hz

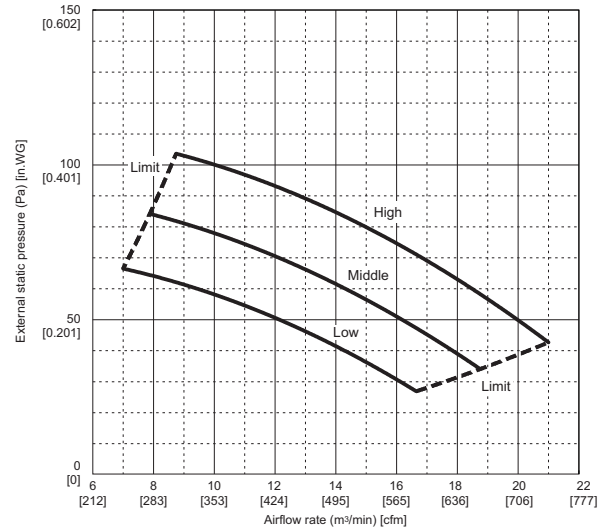

PEAD-A09AA8

(External static pressure 50Pa) 208-230V 60Hz

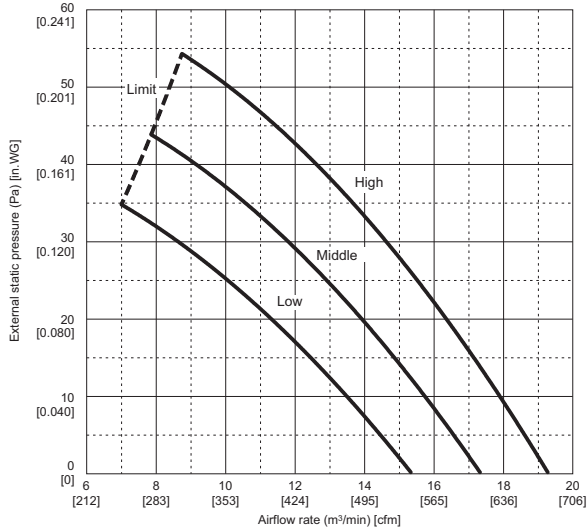

PEAD-A09AA8

(External static pressure 150Pa) 208-230V 60Hz

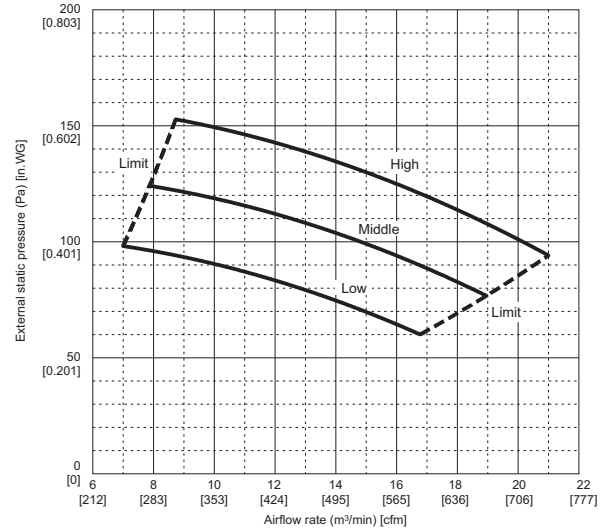

PEAD-A09AA8

(External static pressure 70Pa) 208-230V 60Hz

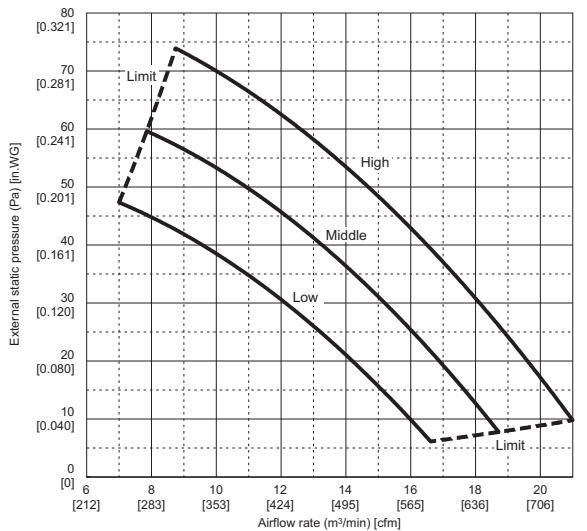

PEAD-A12AA8

(External static pressure 35Pa) 208-230V 60Hz

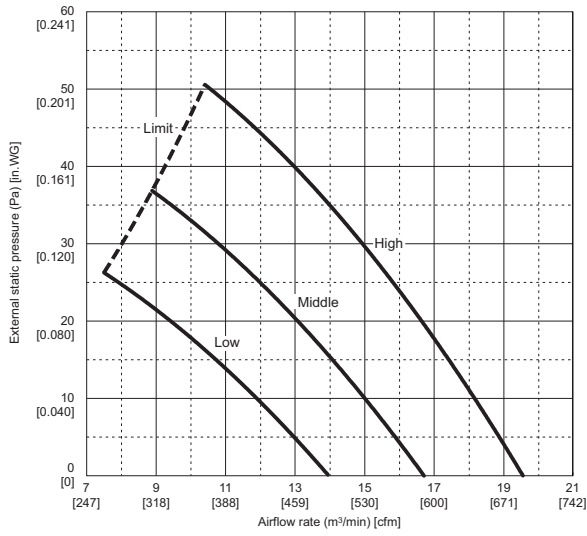

PEAD-A12AA8

(External static pressure 100Pa) 208-230V 60Hz

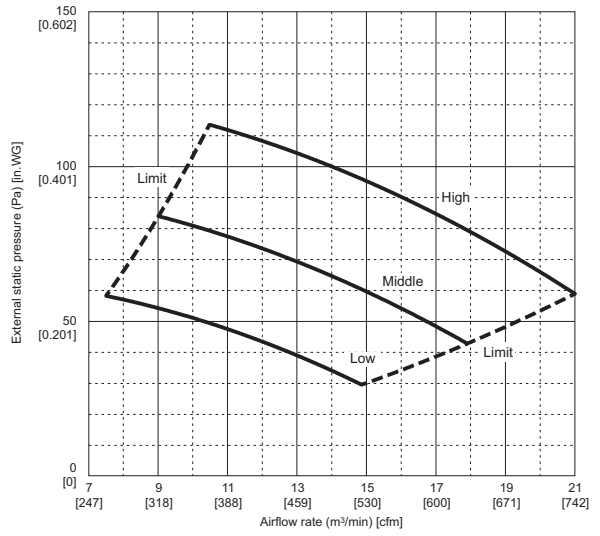

PEAD-A12AA8

(External static pressure 50Pa) 208-230V 60Hz

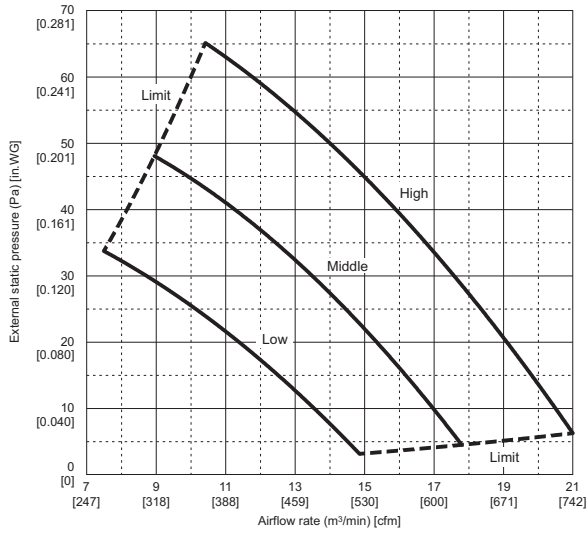

PEAD-A12AA8

(External static pressure 150Pa) 208-230V 60Hz

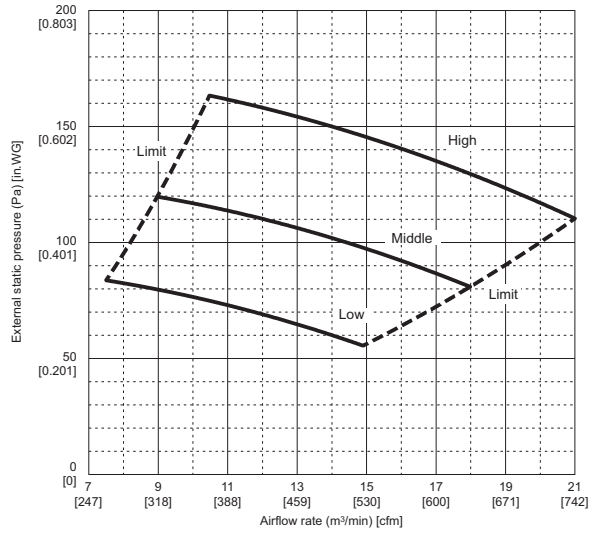

PEAD-A12AA8

(External static pressure 70Pa) 208-230V 60Hz

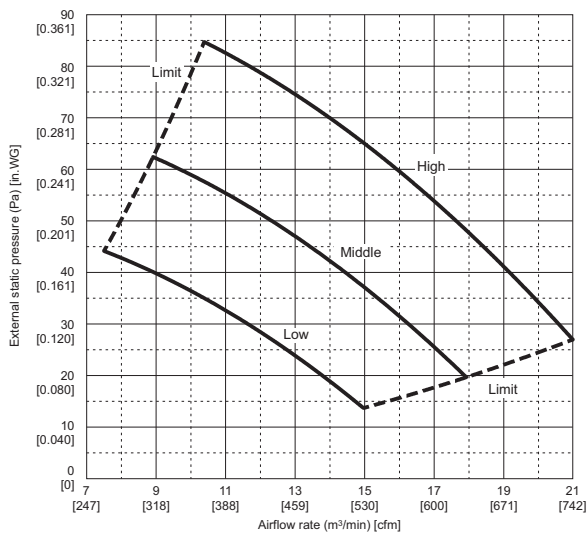

PEAD-A15, 18AA8

(External static pressure 35Pa) 208-230V 60Hz

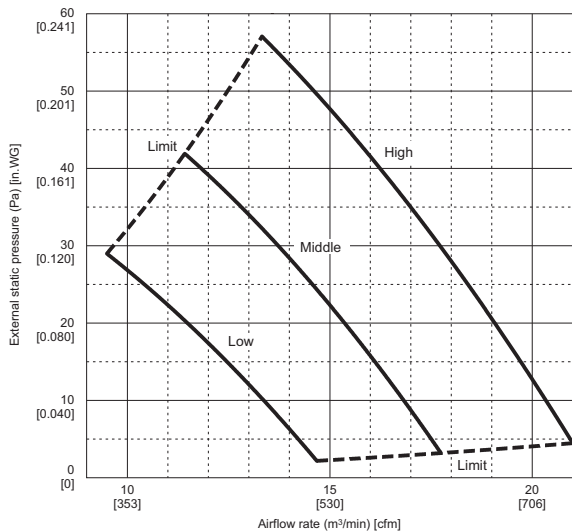

PEAD-A15, 18AA8

(External static pressure 100Pa) 208-230V 60Hz

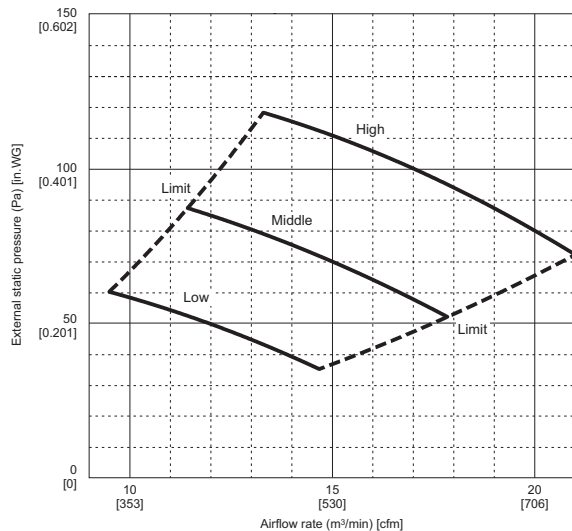

PEAD-A15, 18AA8

(External static pressure 50Pa) 208-230V 60Hz

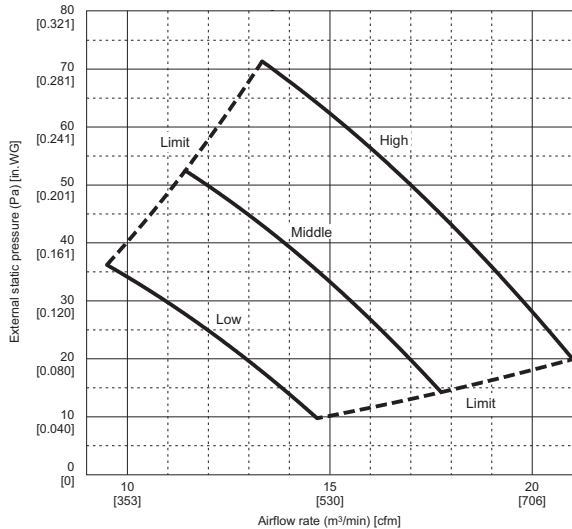

PEAD-A15, 18AA8

(External static pressure 150Pa) 208-230V 60Hz

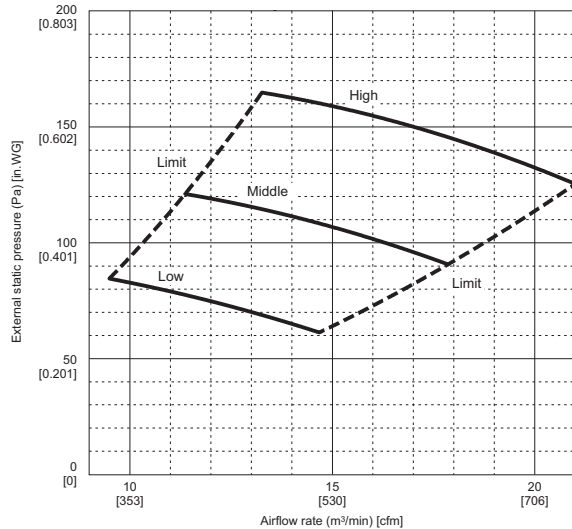

PEAD-A15, 18AA8

(External static pressure 70Pa) 208-230V 60Hz

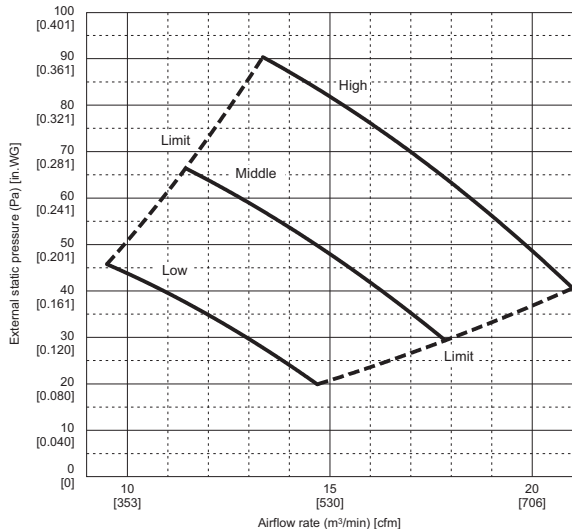

PEAD-A24AA8

(External static pressure 35Pa) 208-230V 60Hz

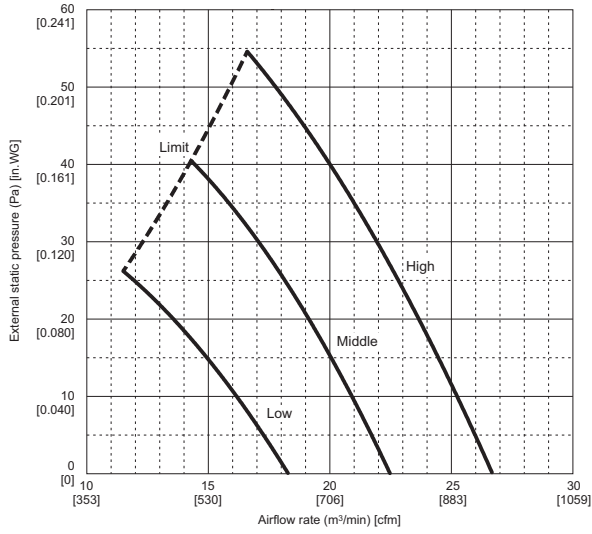

PEAD-A24AA8

(External static pressure 100Pa) 208-230V 60Hz

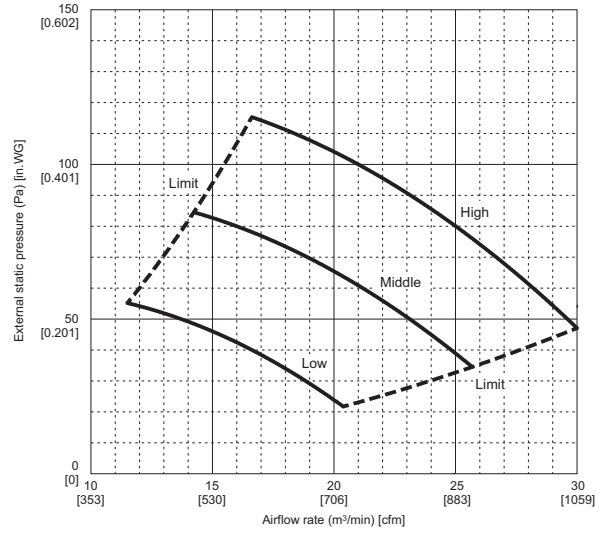

PEAD-A24AA8

(External static pressure 50Pa) 208-230V 60Hz

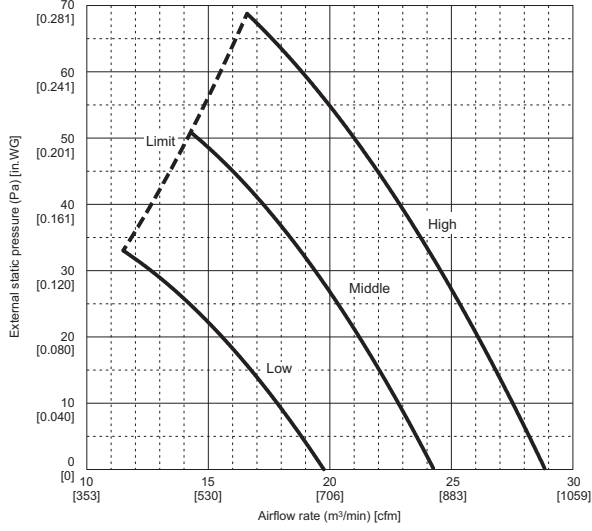

PEAD-A24AA8

(External static pressure 150Pa) 208-230V 60Hz

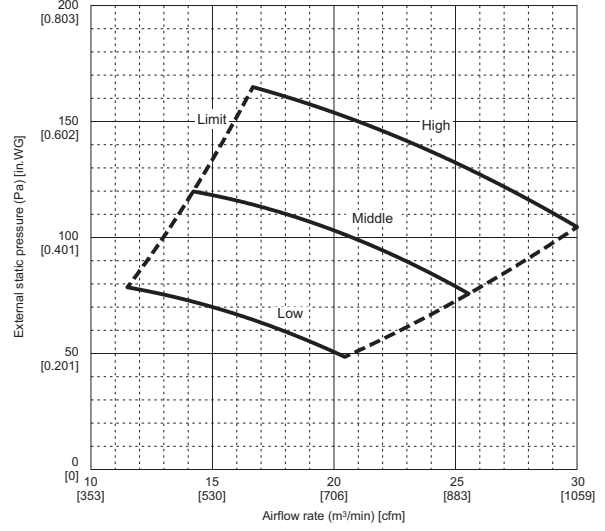

PEAD-A24AA8

(External static pressure 70Pa) 208-230V 60Hz

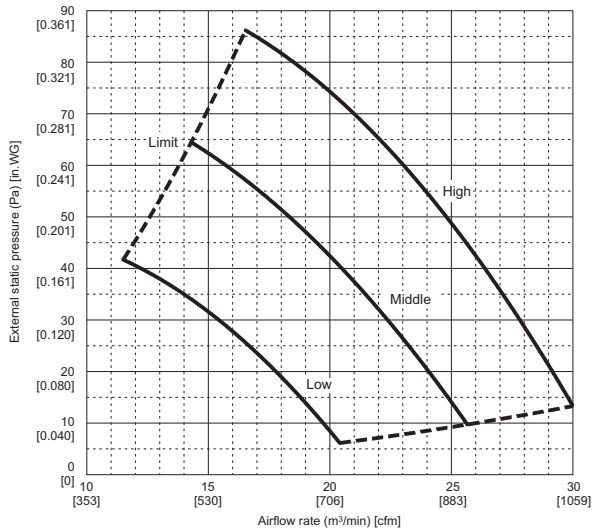

PEAD-A30AA8

(External static pressure 35Pa) 208-230V 60Hz

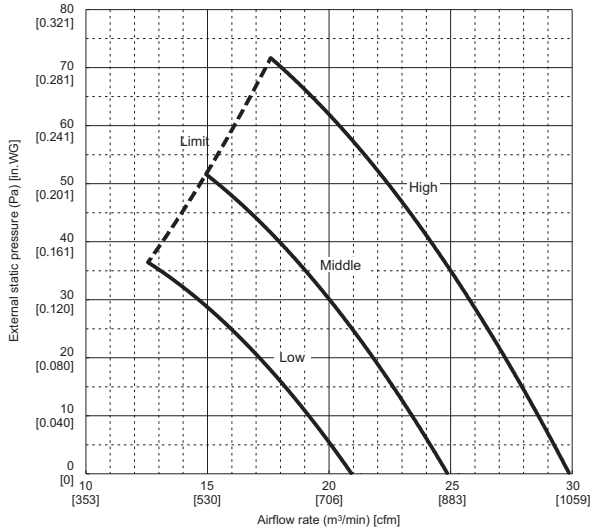

PEAD-A30AA8

(External static pressure 100Pa) 208-230V 60Hz

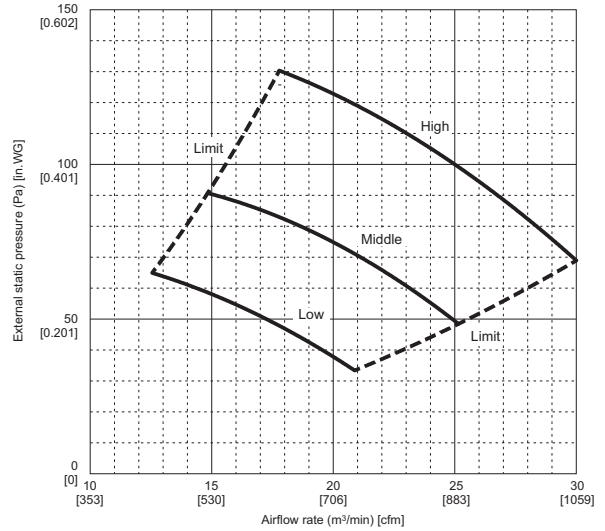

PEAD-A30AA8

(External static pressure 50Pa) 208-230V 60Hz

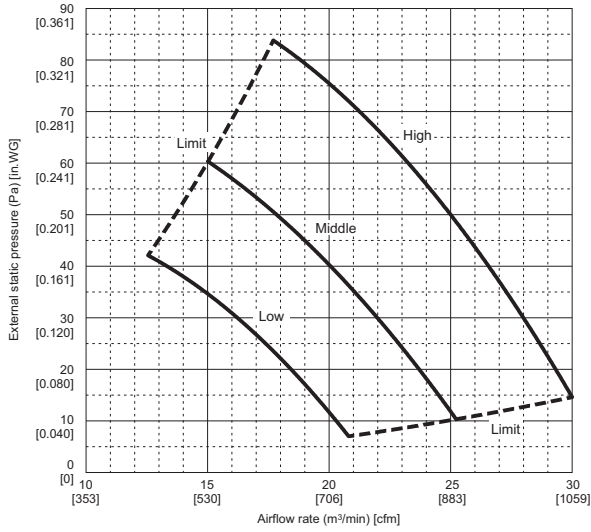

PEAD-A30AA8

(External static pressure 150Pa) 208-230V 60Hz

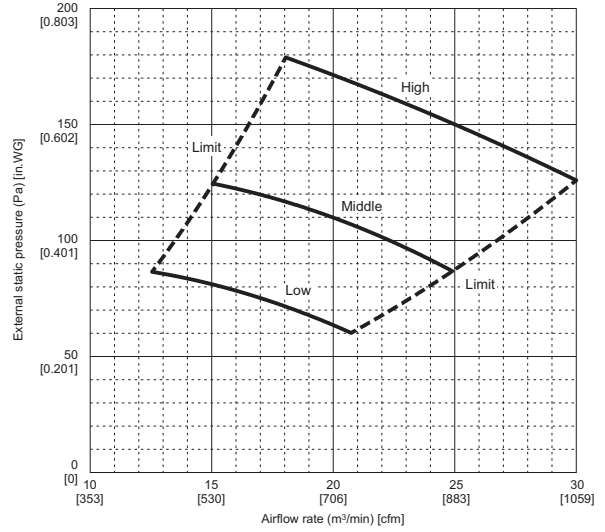

PEAD-A30AA8

(External static pressure 70Pa) 208-230V 60Hz

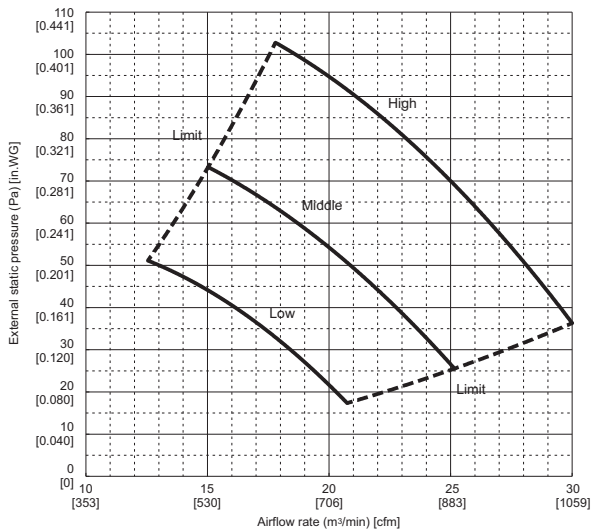

PEAD-A36AA8

(External static pressure 35Pa) 208-230V 60Hz

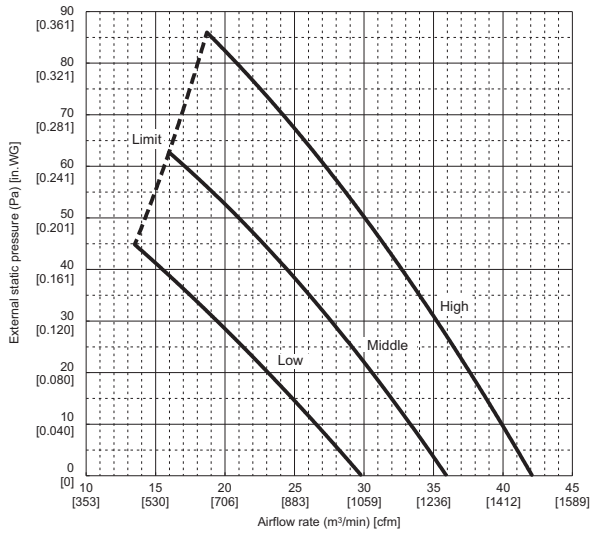

PEAD-A36AA8

(External static pressure 100Pa) 208-230V 60Hz

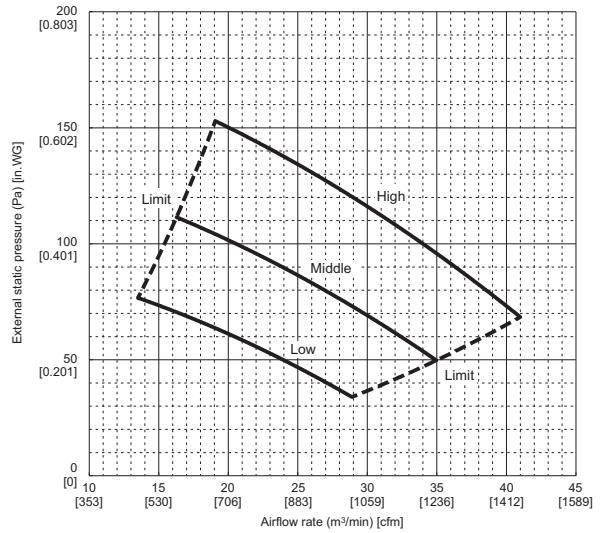

PEAD-A36AA8

(External static pressure 50Pa) 208-230V 60Hz

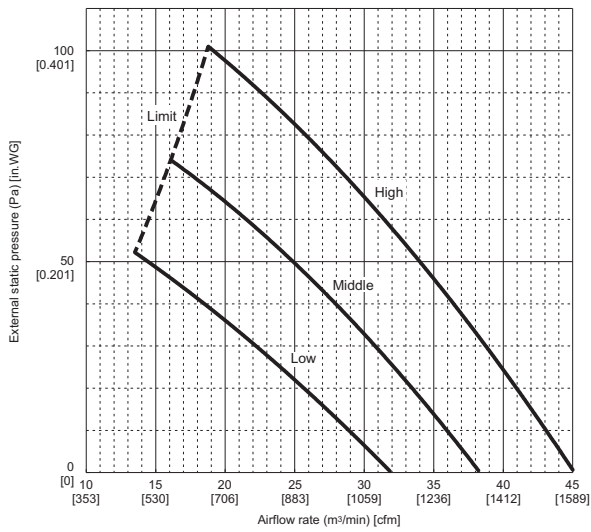

PEAD-A36AA8

(External static pressure 150Pa) 208-230V 60Hz

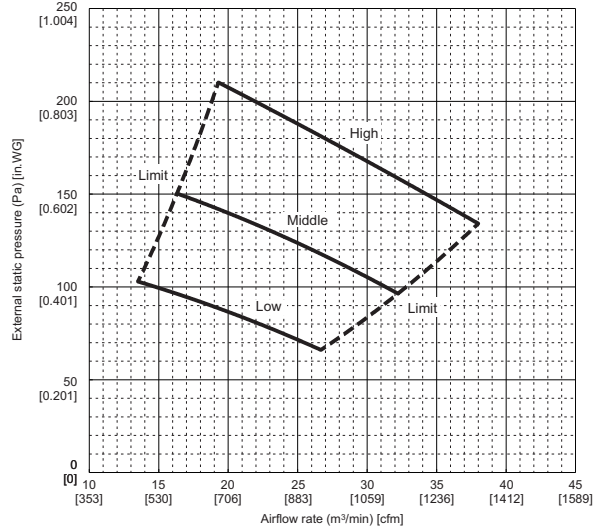

PEAD-A36AA8

(External static pressure 70Pa) 208-230V 60Hz

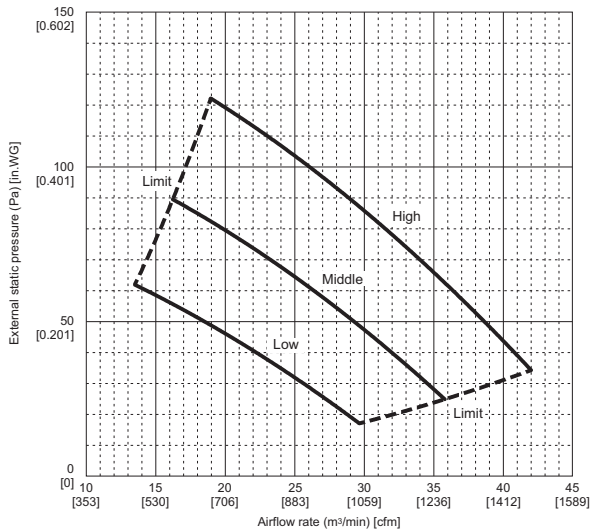

PEAD-A42AA8

(External static pressure 35Pa) 208-230V 60Hz

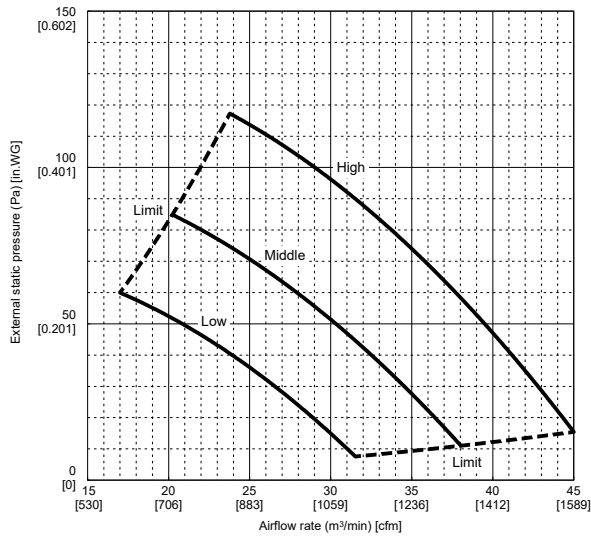

PEAD-A42AA8

(External static pressure 100Pa) 208-230V 60Hz

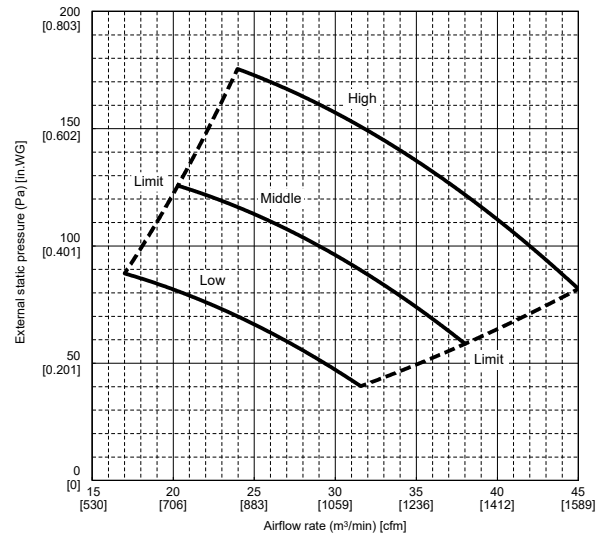

PEAD-A42AA8

(External static pressure 50Pa) 208-230V 60Hz

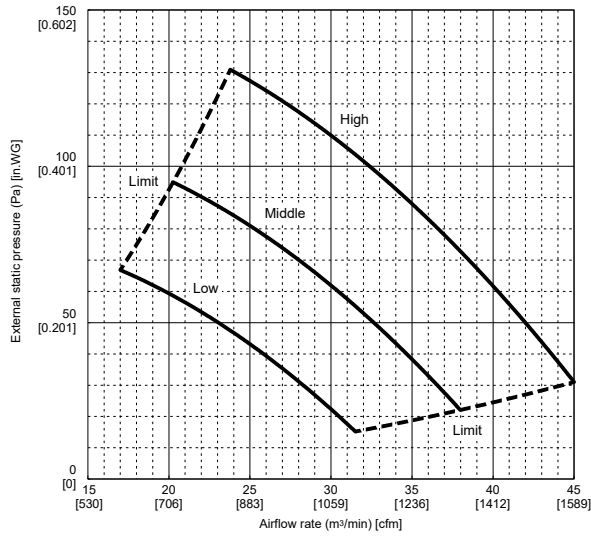

PEAD-A42AA8

(External static pressure 150Pa) 208V 60Hz

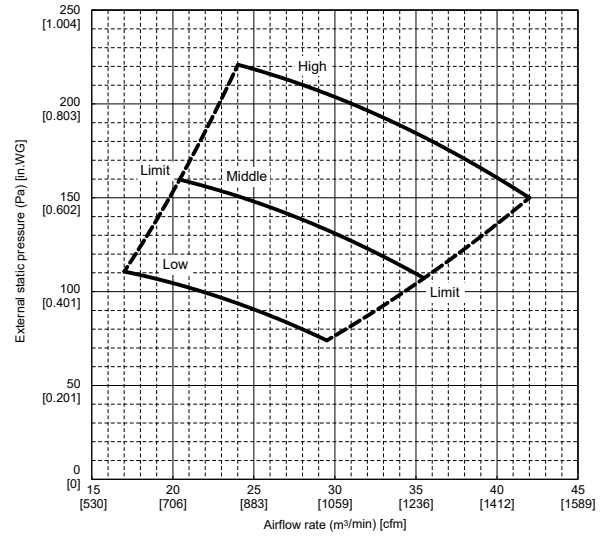

PEAD-A42AA8

(External static pressure 70Pa) 208-230V 60Hz

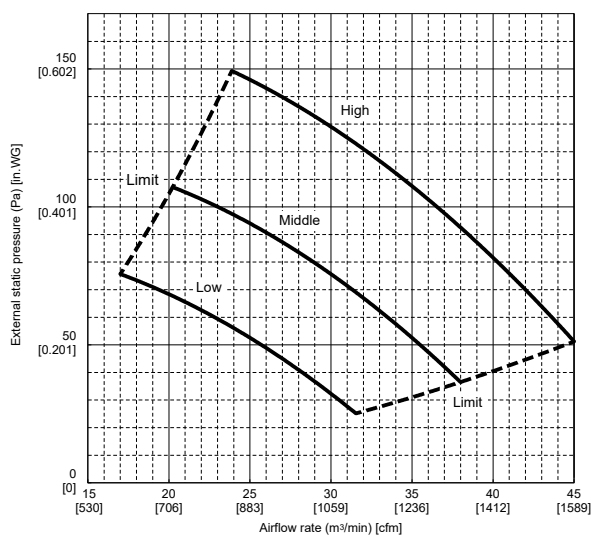

PEAD-A42AA8

(External static pressure 150Pa) 230V 60Hz

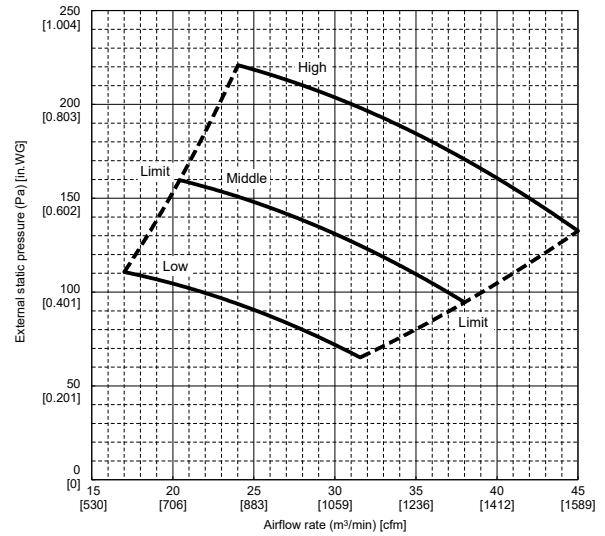

PEAD-A09,12,15,18,24,30,36,42AA8

Air filter 208-230V 60Hz

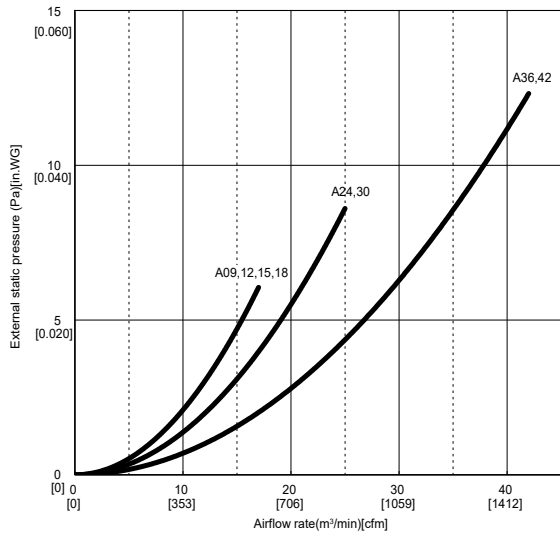

5. SOUND PRESSURE LEVELS

5-1. Sound pressure level Ceiling concealed

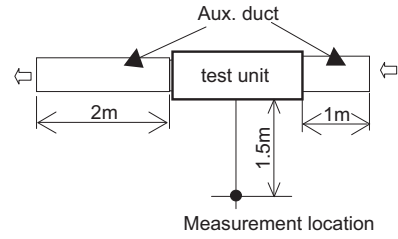

5-2. NC curves PEAD-A09AA8

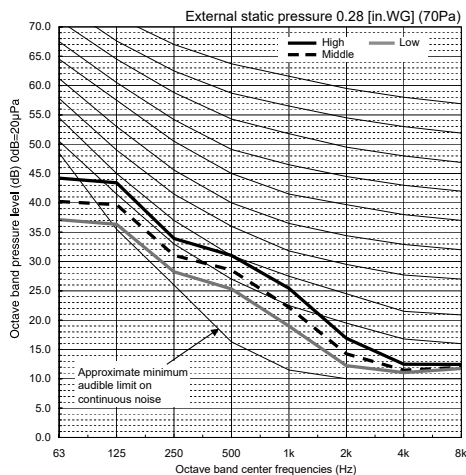
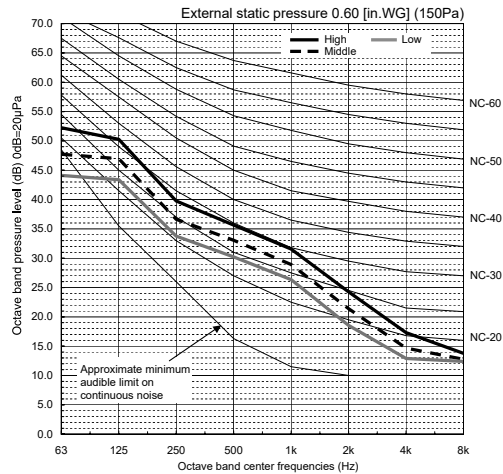
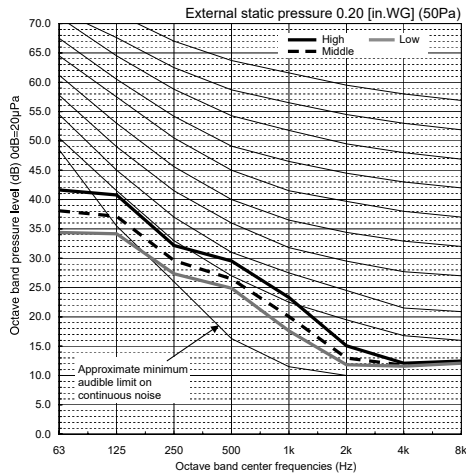
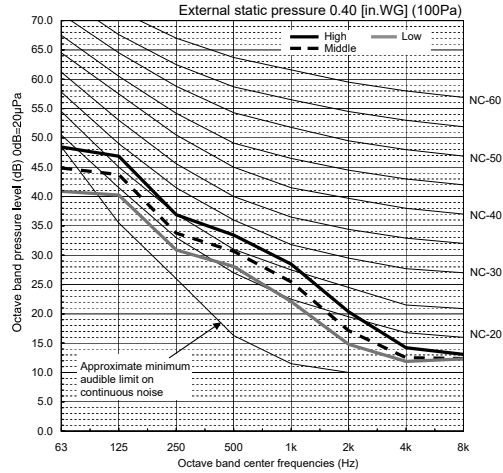
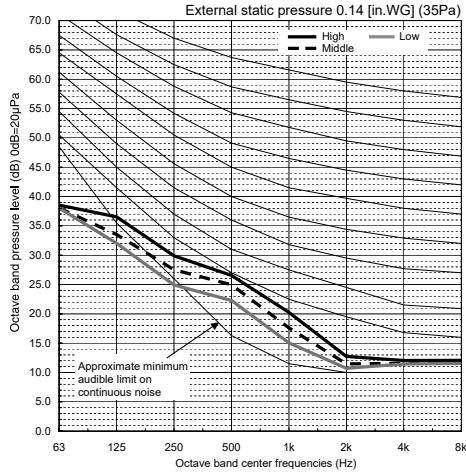

PEAD-A12AA8

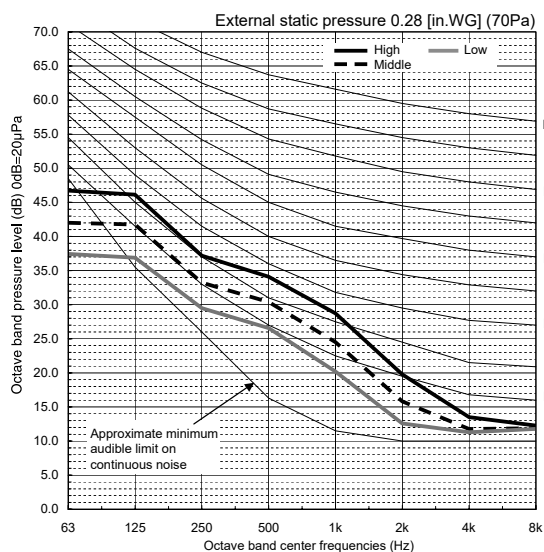
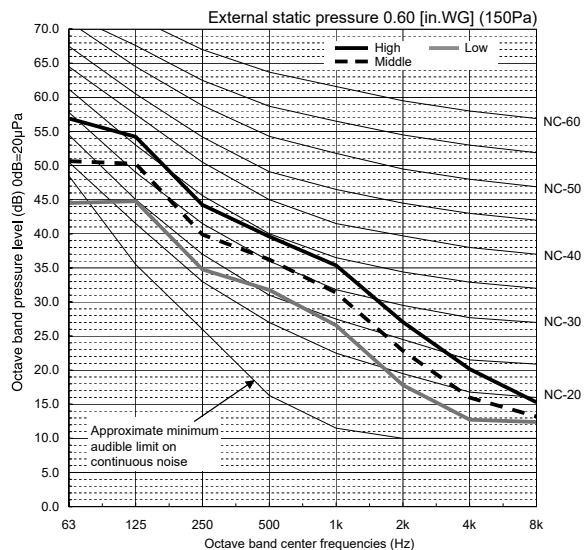
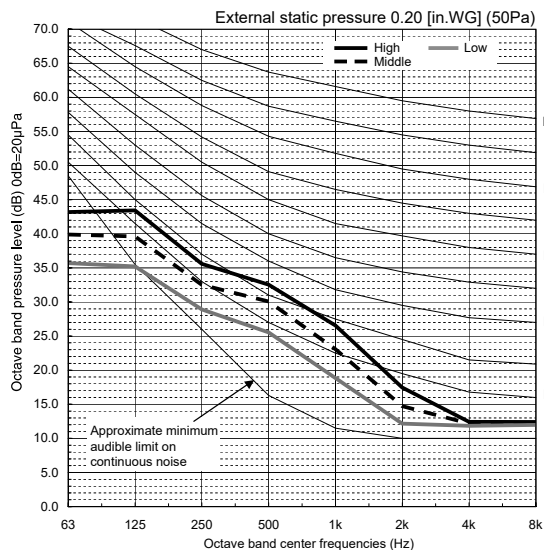
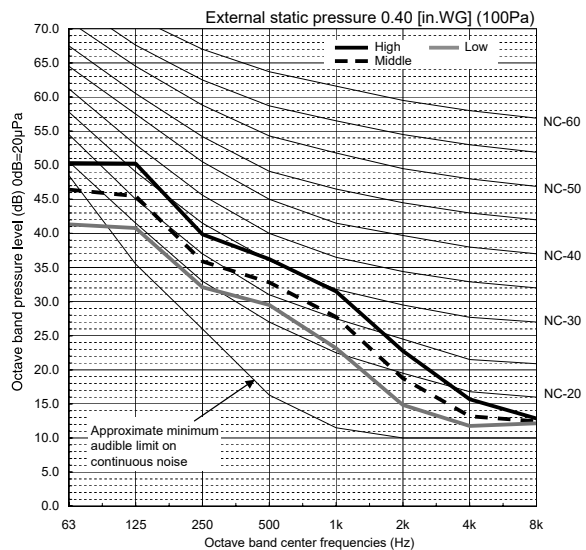
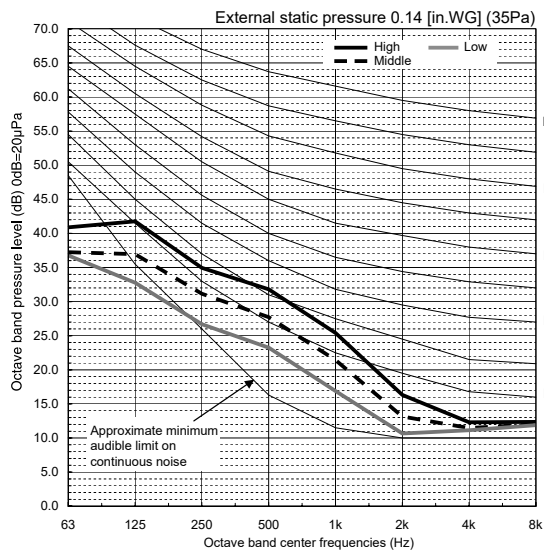

PEAD-A15, 18AA8

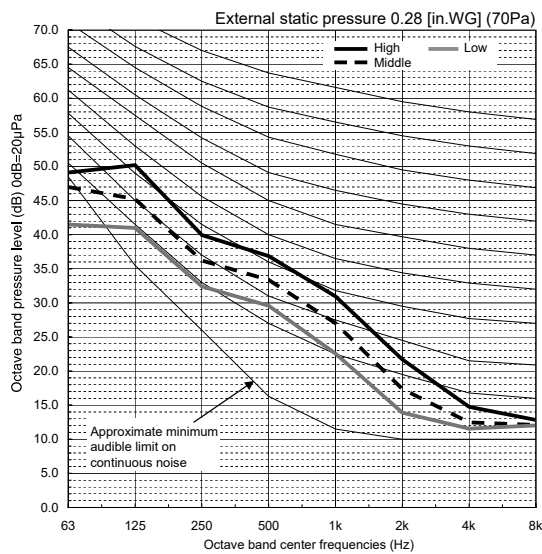
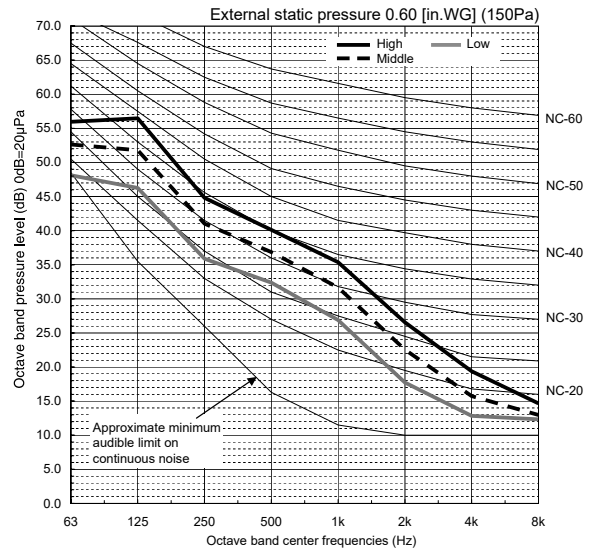
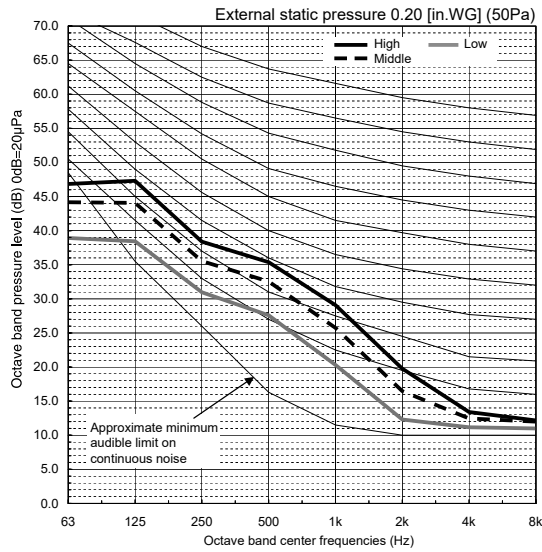
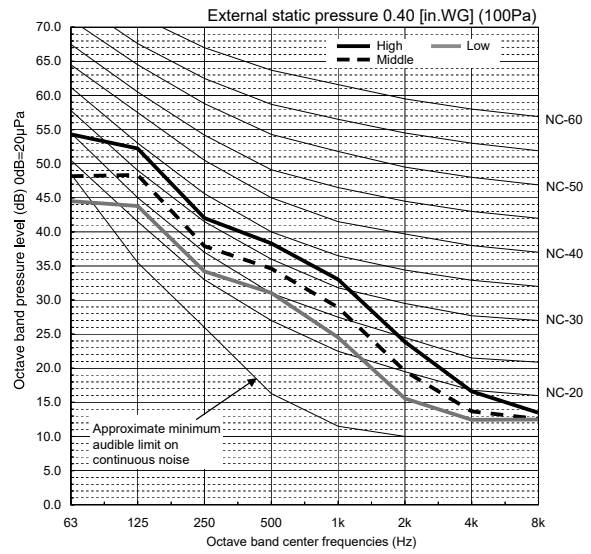
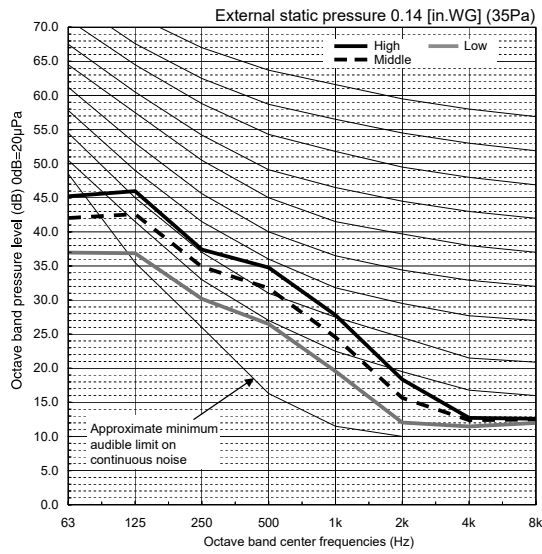

PEAD-A24AA8

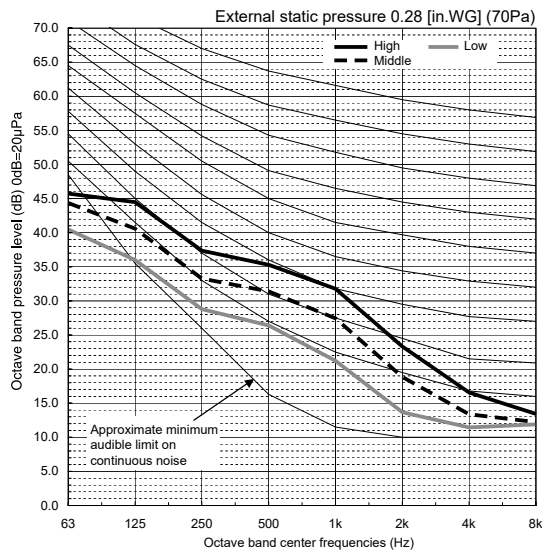
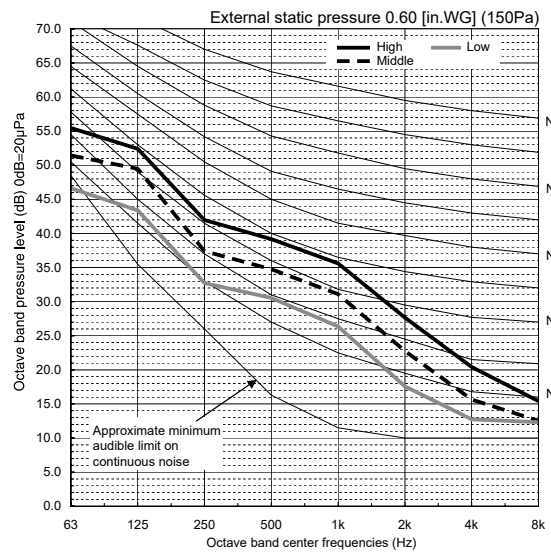
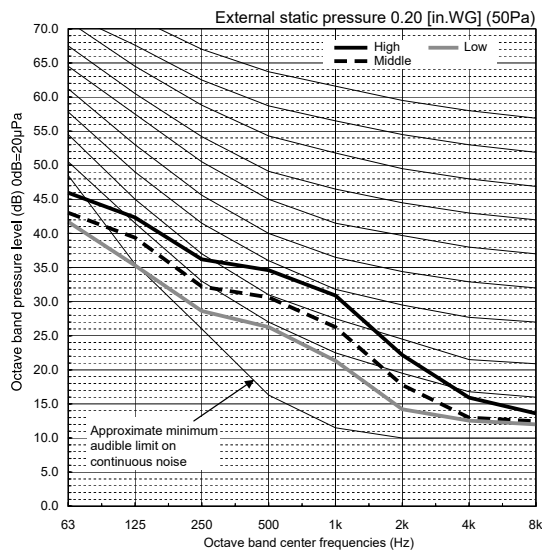
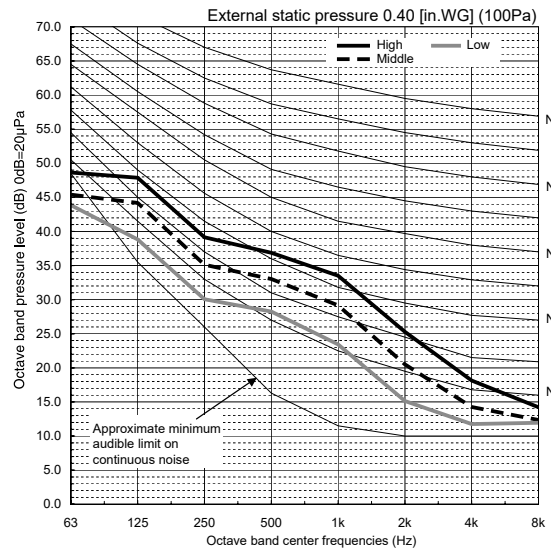
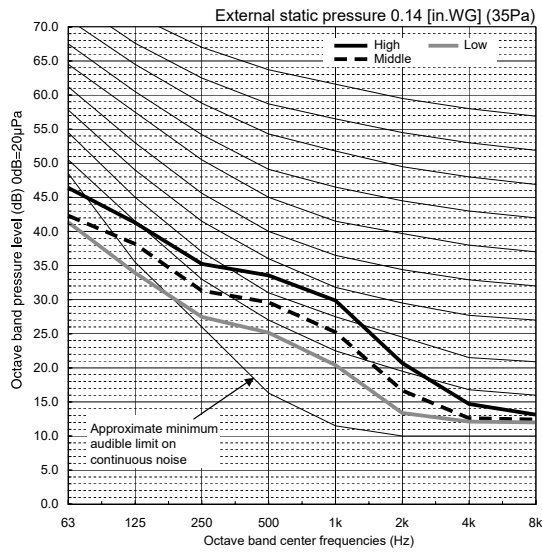

PEAD-A30AA8

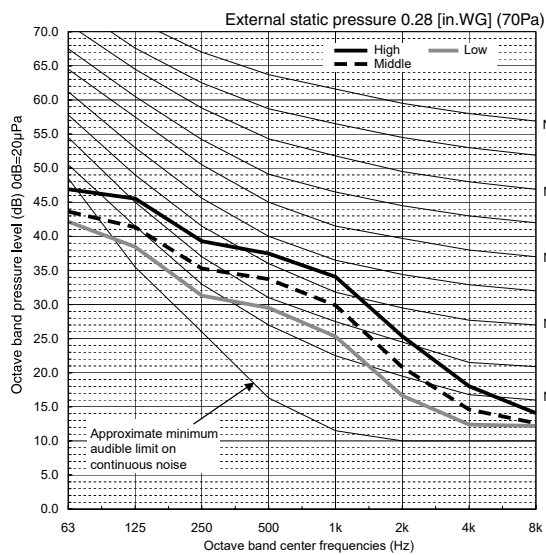
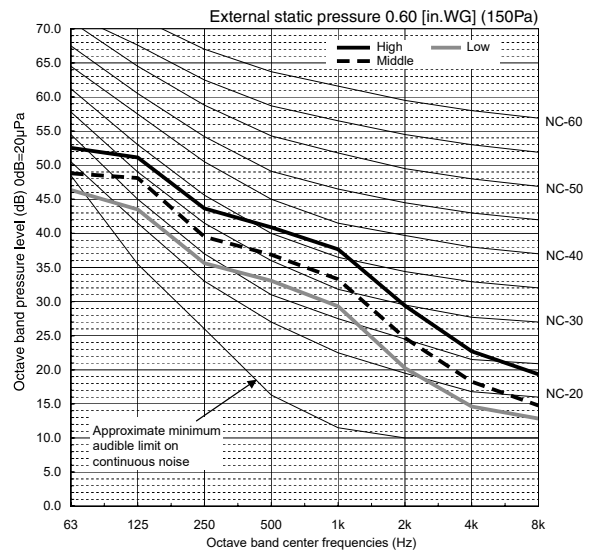
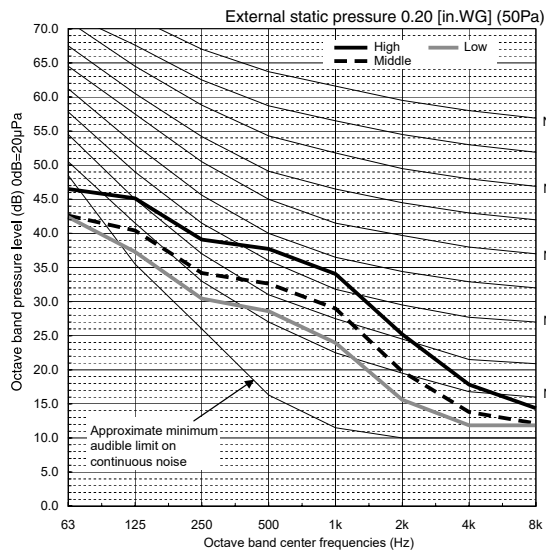
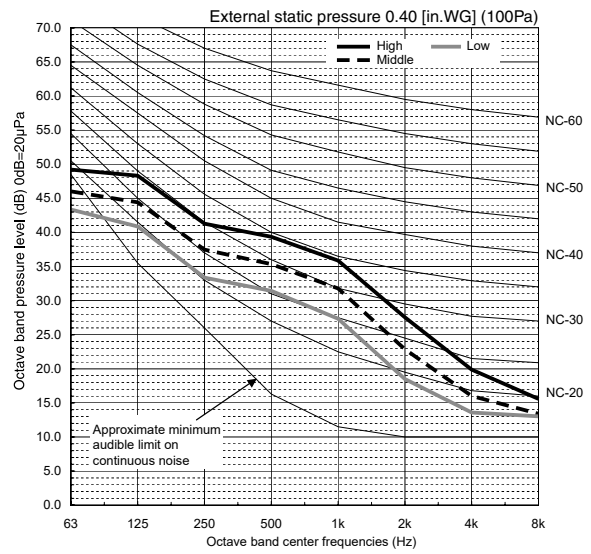
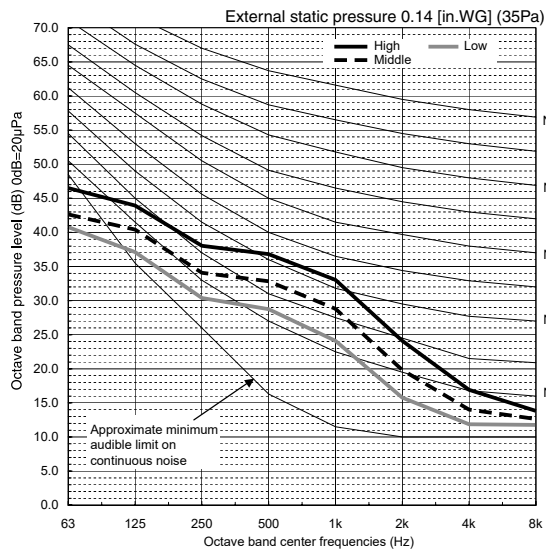

PEAD-A36AA8

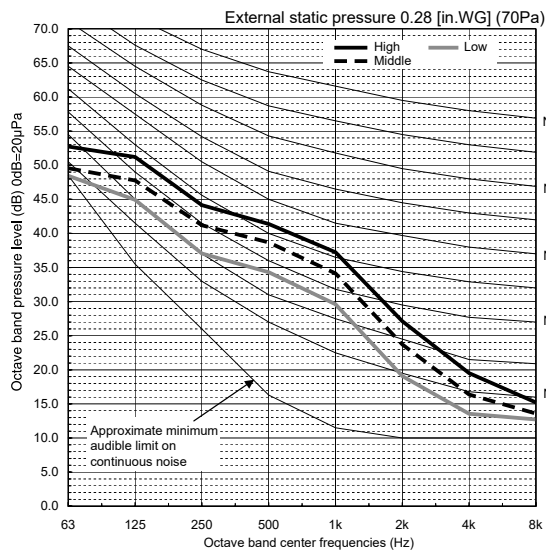
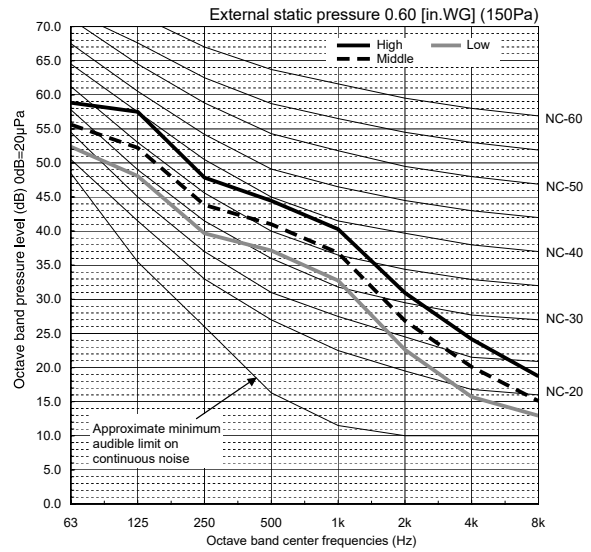
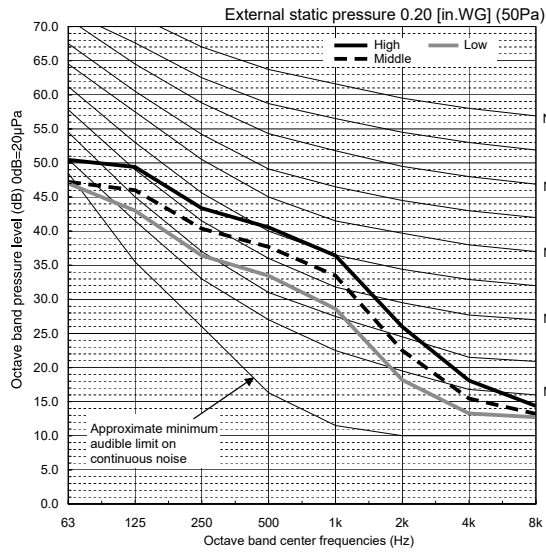
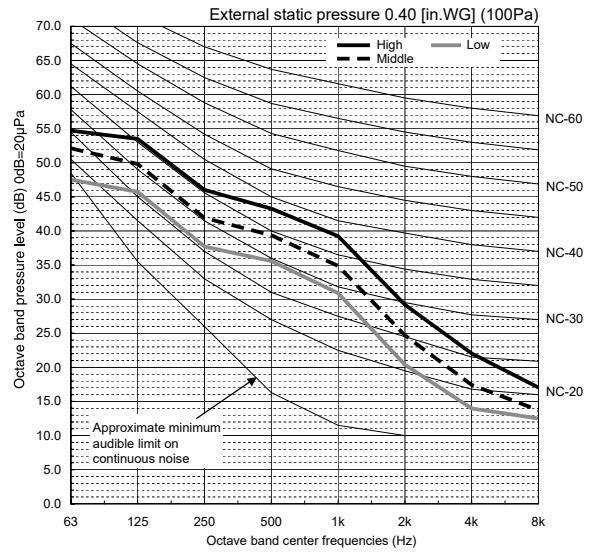
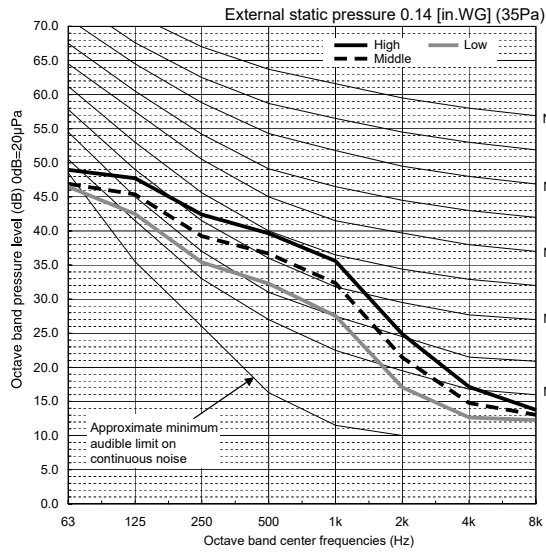

PEAD-A42AA8

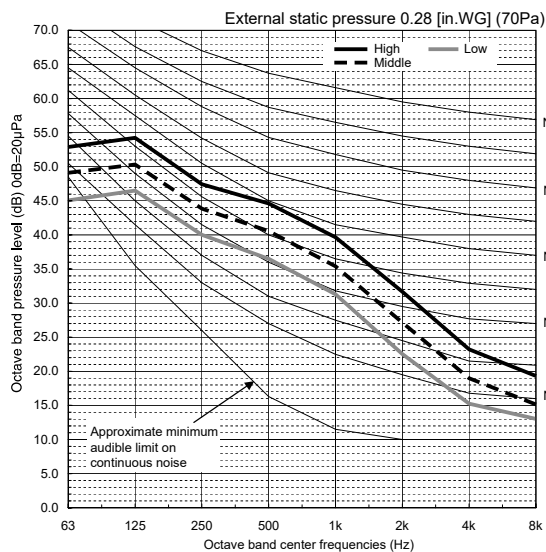
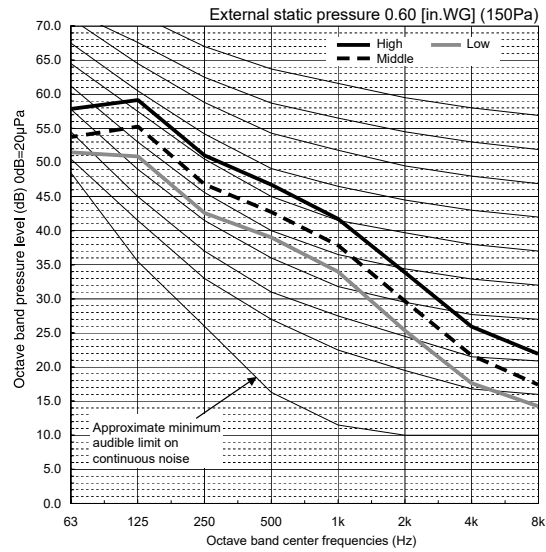
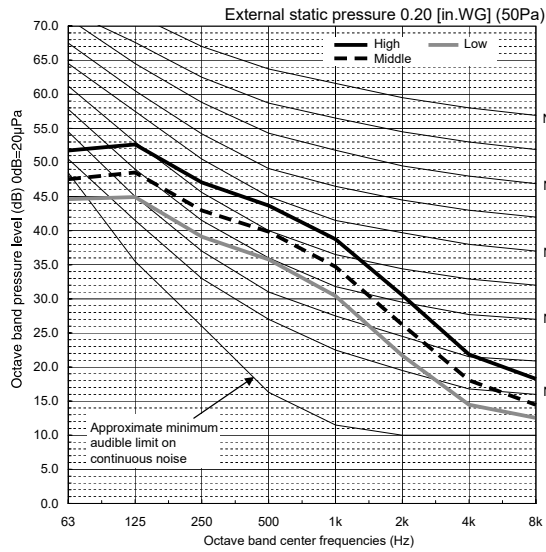
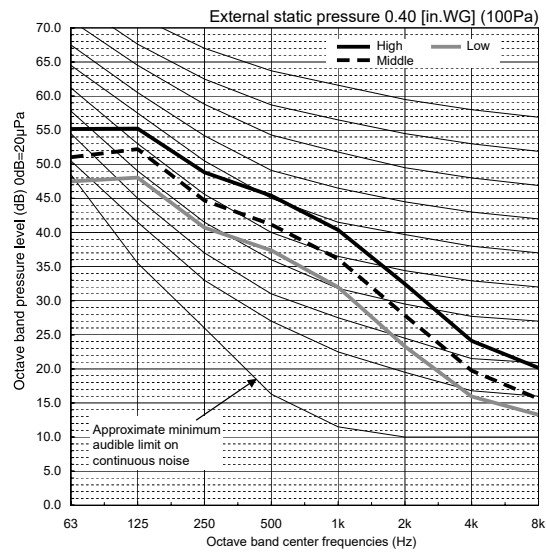
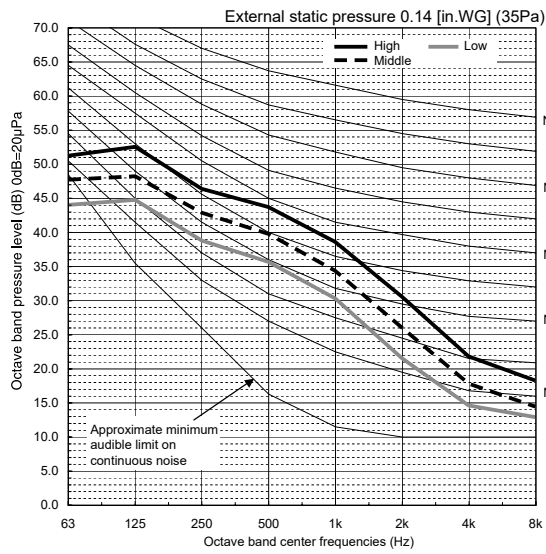

6. OUTLINES & DIMENSIONS

INDOOR UNIT

PEAD-A09, 12, 15, 18, 24, 30, 36, 42AA8

- Notes
1. Use an M10 screw for the suspension bolt (field supply).
 2. Keep the service space for maintenance at the bottom.
 3. This drawing is for PEAD-A09, 12, 15, 18, 24, 30AA8 models, which have 2 fans. PEAD-A36, 42AA8 model has 3 fans.
 4. If the inlet duct is used, remove the air filter (supplied with the unit), then install the filter (field supply) at the suction side.
 5. Heat air to 0°C(32°F) or higher when taking fresh air with a fresh air intake.

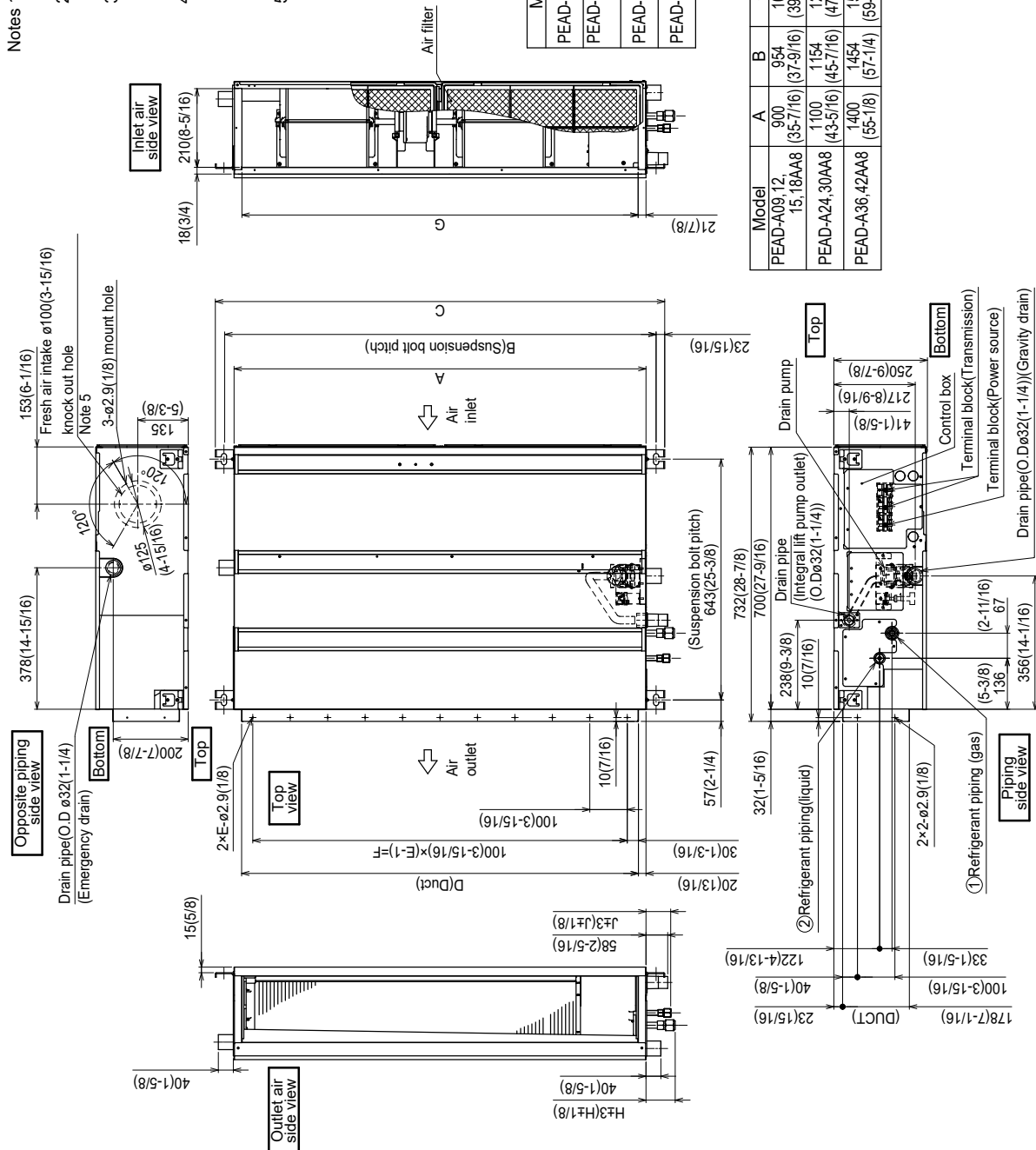

Model	J	① Gas pipe	② Liquid pipe	Unit:mm(in.)
PEAD-A09AA8	62 (2-1/2)	ø9.52 (3/8)	ø6.35 (1/4)	
PEAD-A12, 15, 18AA8	62 (2-1/2)	ø12.7 (1/2)	ø6.35 (1/4)	
PEAD-A24, 30AA8	66 (2-5/8)	ø15.88 (5/8)	ø9.52 (3/8)	
PEAD-A36, 42AA8				

Model	A	B	C	D	E	F	G	H	Unit:mm(in.)
PEAD-A09, 12, 15, 18AA8	900 (35-7/16)	954 (37-9/16)	1000 (39-3/8)	860 (33-7/8)	9	800 (31-1/2)	868 (33-13/16)	72 (2-7/8)	
PEAD-A24, 30AA8	1100 (43-5/16)	1154 (45-7/16)	1200 (47-1/4)	1060 (41-3/4)	11	1000 (39-3/8)	1058 (41-11/16)	78 (3-1/8)	
PEAD-A36, 42AA8	1400 (55-1/8)	1454 (57-1/4)	1500 (59-1/16)	1360 (53-9/16)	14	1300 (51-3/16)	1358 (53-1/2)		

[Maintenance access space]

Secure enough access space to allow for the maintenance, inspection, and replacement of the motor, fan, drain pump, heat exchanger, and control box in one of the following ways.
 Select an installation site for the indoor unit so that its maintenance access space will not be obstructed by beams or other objects.

- (1) When a space of 300mm or more is available below the unit between the unit and the ceiling. (Fig. 1)
- Create access door 1 and 2 (450x450mm each) as shown in Fig. 2.
 (Access door 2 is not required if enough space is available below the unit for a maintenance worker to work in.)
- (2) When a space of less than 300mm is available below the unit between the unit and the ceiling.
 (At least 20mm of space should be left below the unit as shown in Fig. 3.)
- Create access door 1 diagonally below the control box and access door 3 below the unit as shown in Fig. 4.
 or
- Create access door 4 below the control box and the unit as shown in Fig. 5.

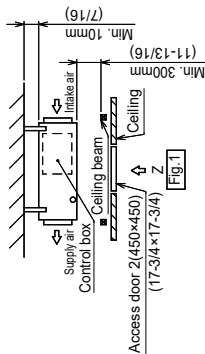

Fig. 1

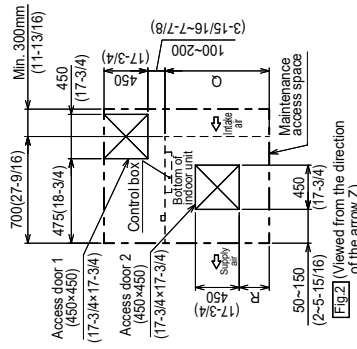

Fig. 2 [Viewed from the direction of the arrow Z]

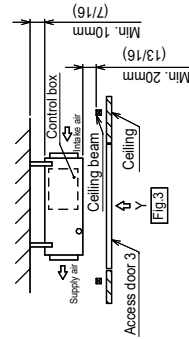

Fig. 3

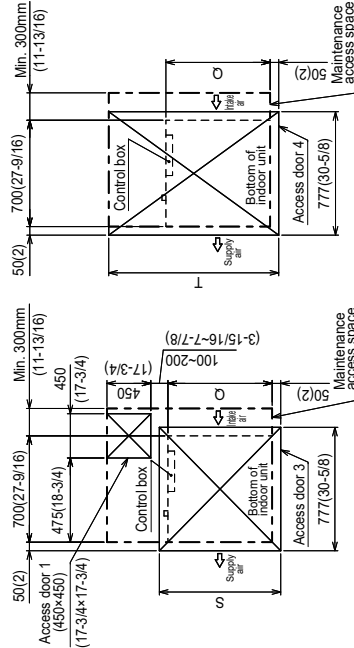

Fig. 4 [Viewed from the direction of the arrow Y]

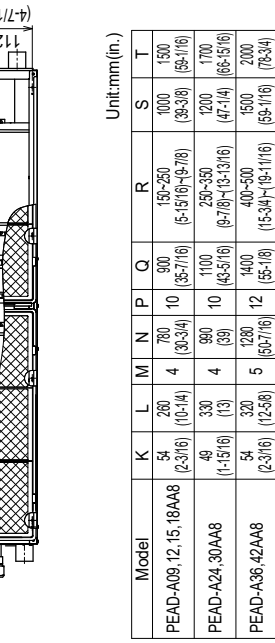
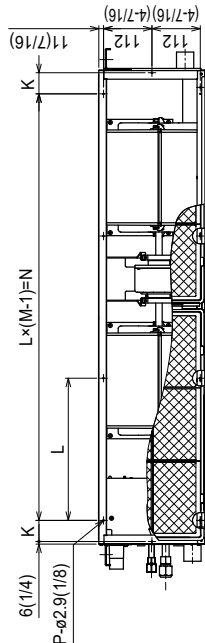
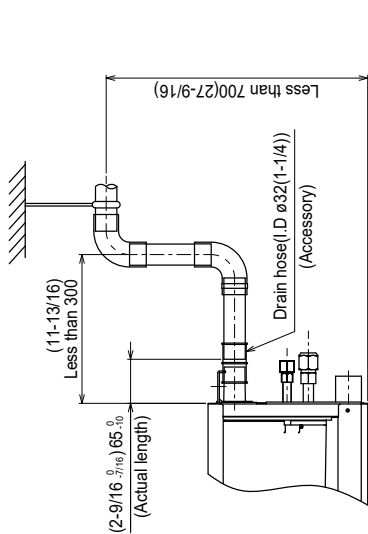

Fig. 5 [Viewed from the direction of the arrow Y]



Model	K	L	M	N	P	Q	R	S	T
PEAD-A10, 12, 15, 18AA8	54 (2-3/16)	280 (10-1/4)	4 (3/32)	780 (30-3/4)	10 (5/16)	900 (35-7/16)	150-250 (5-15/16-9-7/8)	1000 (39-3/8)	1500 (58-1/16)
PEAD-A24, 30AA8	49 (1-15/16)	330 (13)	4 (3/32)	990 (39-5/16)	10 (5/16)	1100 (43-5/16)	250-350 (9-7/8-13-13/16)	1200 (47-1/4)	1700 (66-15/16)
PEAD-A36, 42AA8	54 (2-3/16)	320 (12-5/8)	5 (5/32)	1280 (50-7/16)	12 (15/16)	1400 (55-1/8)	400-500 (15-3/4-19-1/16)	1500 (59-1/16)	2100 (82-3/4)

Unit:mm (in.)

7. WIRING DIAGRAM

PEAD-A09, 12, 15, 18, 24, 30, 36, 42AA8

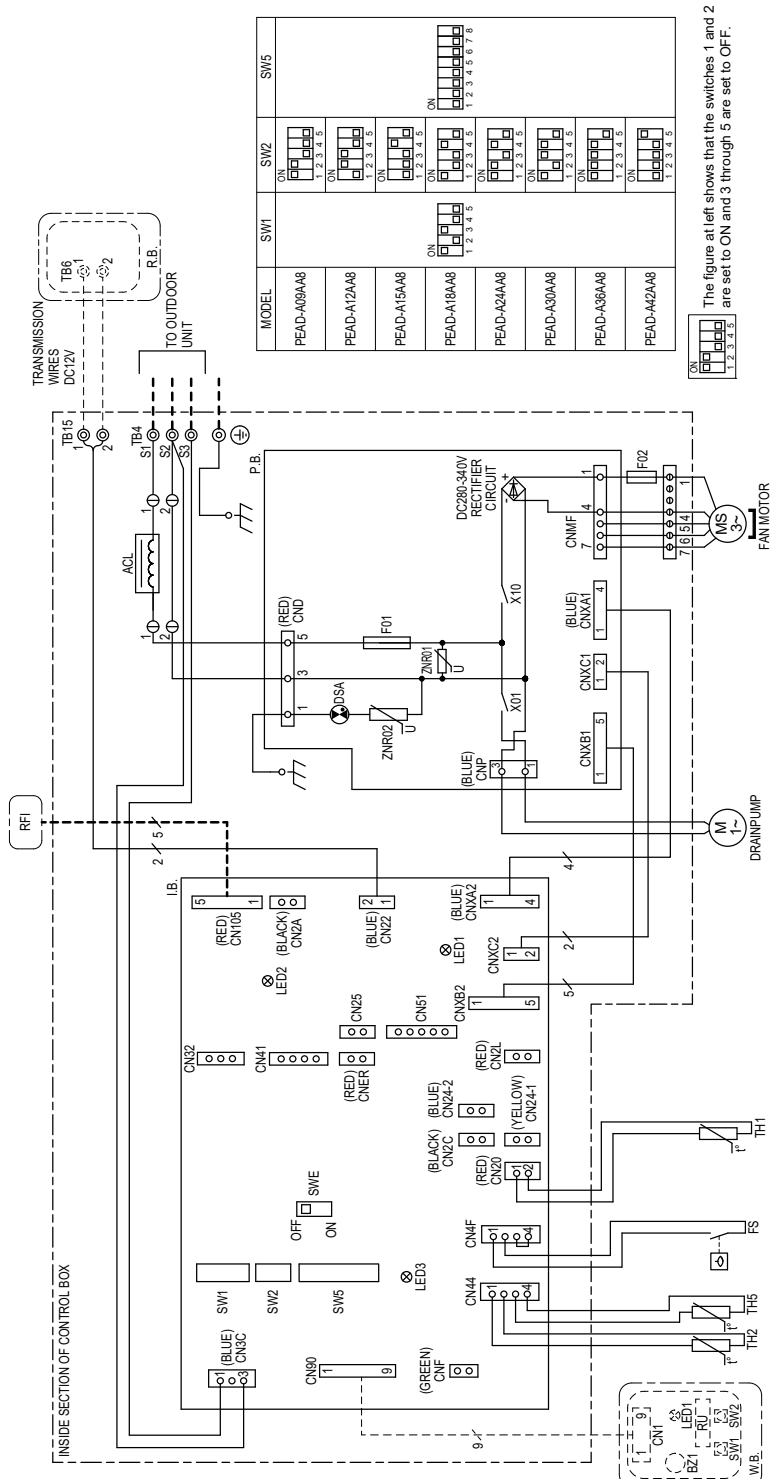

The figure at left shows that the switches 1 through 5 are set to ON and 6 through 10 are set to OFF.

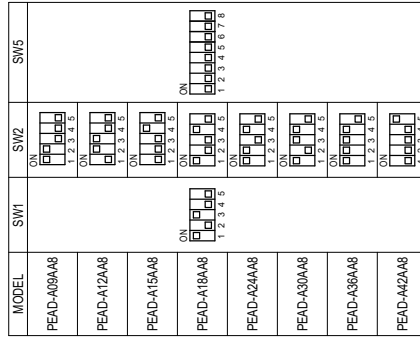

The figure at left shows that the switches 1 and 2 are set to ON and 3 through 5 are set to OFF.

- Notes
- 1 Since the outdoor side electric wiring may change be sure to check the outdoor unit electric wiring for servicing.
 - 2 Indoor and outdoor connecting wires are made with polarities, make wiring matching terminal numbers (S1, S2, S3).
 - 3 Symbols used in wiring diagram above are as follows.
 - ⊙: TERMINAL
 - ⊗: CONNCTOR
 - (HEAVY DOTTED LINE): FIELD WIRING
 - - - (THIN DOTTED LINE): OPTIONAL PARTS
 - ④: USE COPPER SUPPLY WIRES.
 - UTILISER DES FILS D'ALIMENTATION EN CUIVRE.

SYMBOL EXPLANATION

SYMBOL	NAME	SYMBOL	NAME	SYMBOL	NAME
I.B.	INDOOR CONTROLLER BOARD	I.B.	INDOOR CONTROLLER BOARD	TERMINAL BLOCK (INDOOR/OUTDOOR CONNECTING LINE)	TB4
CN24-1	CONNECTOR (HEATER CONTROL 1ST)	SW1	SWITCH FOR MODEL SELECTION	TERMINAL BLOCK (REMOTE CONTROLLER TRANSMISSION LINE)	TB15
CN24-2	CONNECTOR (HEATER CONTROL 2ND)	SW2	SWITCH FOR CAPACITY CODE	FUSE DC-400V 3A SH/11	F02
CN25	CONNECTOR (HUMIDITY OUTPUT)	SW5	SWITCH FOR MODE SELECTION	OPTIONAL PARTS	
CN2A	CONNECTOR (0-10V ANALOG INPUT)	SWE	CONNECTOR (EMERGENCY OPERATION)	IR WIRELESS REMOTE CONTROLLER BOARD	W.B.
CN2C	CONNECTOR (ERV OUTPUT)	F01	POWER SUPPLY BOARD	R.U. RECEIVING UNIT	RU
CN2L	CONNECTOR (LOSSWAY)	ZNR01.02	FUSE AC250V 6.3A	B.Z1 LED (RUN INDICATOR)	BZ1
CN31	CONNECTOR (REMOTE SWITCH)	ARRESTOR	VARISTOR	LED1 LED (HEATING ON/OFF)	LED1
CN41	CONNECTOR (HA TERMINAL-A)	X01	AUX RELAY	SW1 SWITCH (HEATING ON/OFF)	SW1
CN80	CONNECTOR (WIRELESS)	X10	AUX RELAY	SW2 SWITCH (COOLING ON/OFF)	SW2
CN06	CONNECTOR (RADIO FREQUENCY INTERFACE)	TH1	IN FACE AIR TEMP. THERMISTOR	Wired Remote Controller Board	W.R.C.B.
LED1	LED (POWER SUPPLY)	TH2	PIPE TEMP. THERMISTOR LIQUID	TERMINAL BLOCK (REMOTE CONTROLLER TRANSMISSION LINE)	TB8
LED2	LED (REMOTE CONTROLLER SUPPLY)	TH5	COND./EVA. TEMP. THERMISTOR		
LED3	LED (TRANSMISSION INDOOR/OUTDOOR)	ACL	AC REACTOR (POWER FACTOR IMPROVEMENT)		
CNER	CONNECTOR (ERV INPUT)	FS	FLOAT SWITCH		
CNF	CONNECTOR (HUMIDITY INPUT)	RFI	RADIO FREQUENCY INTERFACE FOR RF THERMOSTAT		

8. REFRIGERANT SYSTEM DIAGRAM

PEAD-A09, 12, 15, 18, 24, 30, 36, 42AA8

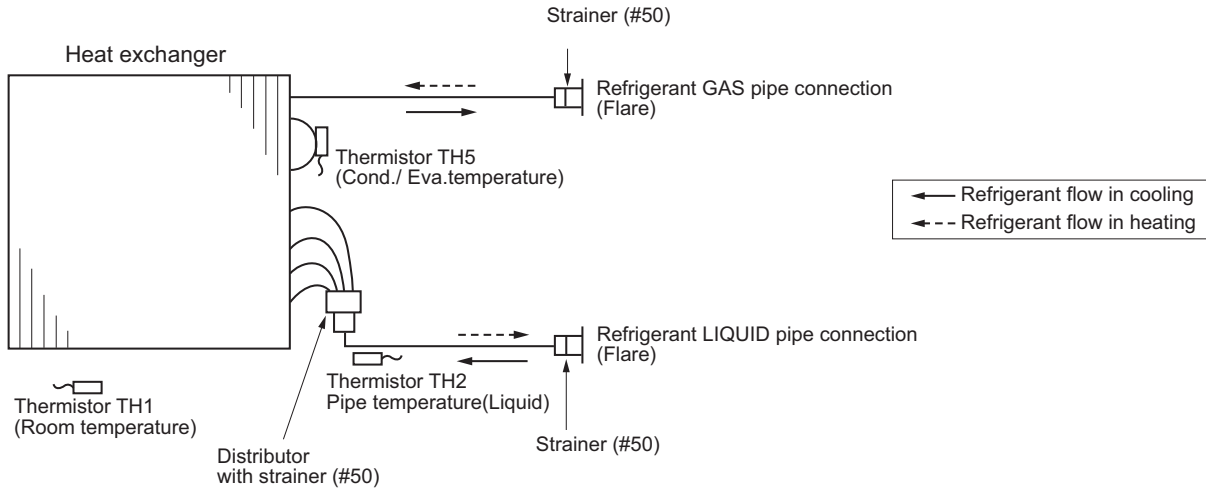

9. HEATER CONTROL

9-1. CAUTIONS RELATED TO HEATER

- Exercise caution when using any auxiliary heat source and follow all third party manufacturer instructions and safety guidelines for installation and usage.
- Any auxiliary heat source connected to this unit via the CN24 connection must have an independent temperature control mechanism. Failure to install and maintain such temperature control mechanism may void the warranty for this unit.
- Mitsubishi Electric shall not bear any warranty obligation or other liability for any damage or loss in connection with such third party auxiliary heaters.

9-2. CONTROL SPECIFICATIONS AND FUNCTION SETTING

- Table 1 shows the mode setting for the field-installed heater.

Table 1 [Function Table]

Select unit numbers 01 to 03 or all units (AL [wired remote controller] / 07 [IR wireless remote controller])

Mode (function) No.		Factory Setting	Mode	Heater Operation In Error	Heater Operation During Defrost	Fan Control When Heater ON
Wired remote controller (RF thermostat)						
11 (111)	23 (123)					
1	1	•	No Heater Present			
2	1	-	Heater Available	OFF	OFF	High
			Disable heater during Defrost and Error			
2	2	-	Heater Available	ON	ON	High
			Enable heater and fan during Defrost and Error *1			

*1 Heater will not operate during all error modes. Heater will only operate during a communication error between indoor unit and outdoor unit.

- Table 2 shows how the field-installed heater is controlled.

Table. 2 [Heater Control Table]

Mode Change	Condition				
EH1 ON	$(T_o - T_{RA}) > 2.7\text{ }^\circ\text{F [1.5 }^\circ\text{C]}$	AND	T_{RA} has not increased by $0.9\text{ }^\circ\text{F [0.5}^\circ\text{C]}$ in X min		
EH2 ON	$(T_o - T_{RA}) > 2.7\text{ }^\circ\text{F [1.5 }^\circ\text{C]}$	AND	T_{RA} has not increased by $0.9\text{ }^\circ\text{F [0.5}^\circ\text{C]}$ in 8 min	AND	EH1 ON for > 8 min
EH1 OFF	$(T_o - T_{RA}) \leq 0.9\text{ }^\circ\text{F [0.5}^\circ\text{C]}$				
EH2 OFF					
KEY <ul style="list-style-type: none"> • EH1: Electric Heater 1 • EH2: Electric Heater 2 • To: Set point temperature • T_{RA}: Return Air temperature • X: Time delay (Selectable. Default is 20 min. Selectable to 10, 15, or 25 min) 					

- Table 3 shows how the time delay is selected

Table. 3 [Time Delay Selection Table]

Request Code ^{*1}	Action ^{*3}
390	Monitor Time Delay Setting
391	Set Time Delay to 10 minutes
392	Set Time Delay to 15 minutes
393	Set Time Delay to 20 minutes ^{*2}
394	Set Time Delay to 25 minutes

Notes:

1. Both main and sub unit should be set in the same setting.
2. Every time replacing indoor controller board for serving, the function should be set again.
3. Stop the air-conditioner operation before changing the heater ON delay time.

*1 Time delay can only be selected with MA controller. If use of a non-MA controller is desired, the time delay must first be selected with the MA controller. Then the non-MA controller can be attached and used.

*2 The default time delay setting is 20 minutes.

*3 All delay times are approximate. It takes a few minutes to turn heater ON after the heater ON delay time has passed.

- Chart 1 and Table 4 show an example of heater operation.

Chart 1 [Heater Operation Example]

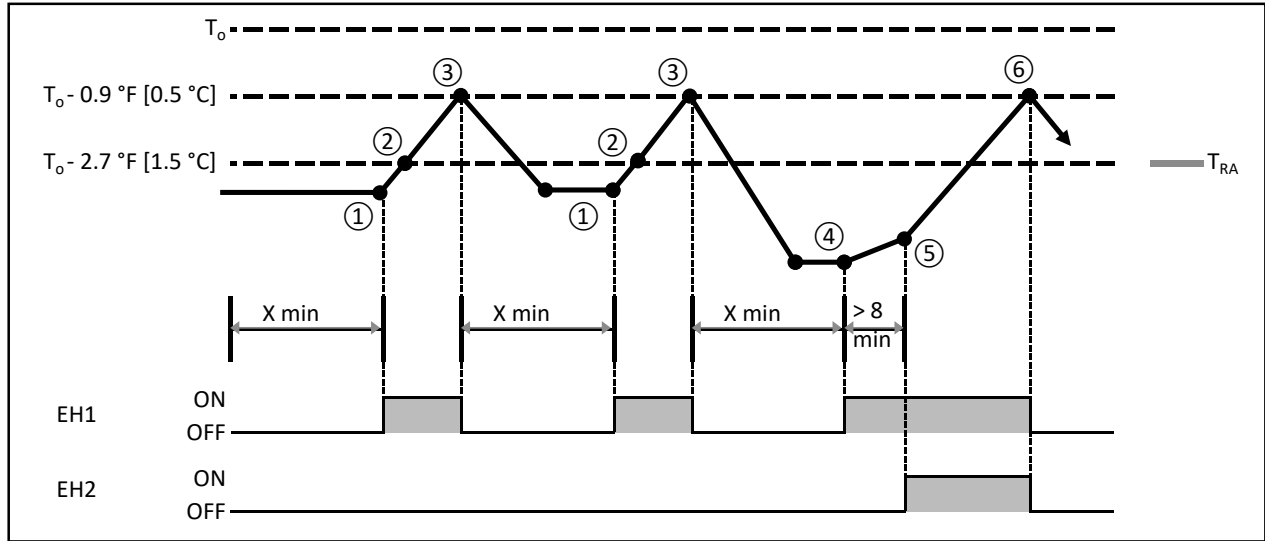

Table. 4 [Heater Operation Example]

Step	Condition			Result
①	$(T_o - T_{RA}) > 2.7 \text{ }^\circ\text{F}$ [1.5 °C]	AND	T_{RA} has not increased by 0.9 °F [0.5°C] in X min	EH1 ON
②	$(T_o - T_{RA}) < 2.7 \text{ }^\circ\text{F}$ [1.5 °C]	AND	T_{RA} increasing faster than 0.9 °F [0.5°C] in 8 min	EH2 not ON
③	$(T_o - T_{RA}) < 0.9 \text{ }^\circ\text{F}$ [0.5°C]			EH1 OFF
④	$(T_o - T_{RA}) > 2.7 \text{ }^\circ\text{F}$ [1.5 °C]	AND	T_{RA} has not increased by 0.9 °F [0.5°C] in X min	EH1 ON
⑤	$(T_o - T_{RA}) > 2.7 \text{ }^\circ\text{F}$ [1.5 °C]	AND	T_{RA} not increasing faster than 0.9 °F [0.5°C] in 8 min	EH2 ON
⑥	$(T_o - T_{RA}) < 0.9 \text{ }^\circ\text{F}$ [0.5°C]			EH1 OFF EH2 OFF

9-3. FAN CONTROL

By setting the Mode No. 11 in the Function Table in section 9-1 and using CN4Y on the optional parts PAC-YU25HT, the following patterns of fan control will become possible when [DEFROST] or [ERROR] is displayed.

Fan control patterns when [DEFROST] or [ERROR] is displayed

	Heater is installed in the duct.	No heater is installed in the duct.
Use of CN4Y (PAC-YU25HT)	Unused*	Used
Heater is off.	Fan OFF	Fan OFF
Heater is on.	Fan ON (High)	Fan OFF

While the heater is on, the fan will operate at high speed regardless of the fan setting on the remote controller.



*** If a heater is installed in the duct, do not use CN4Y. By doing so, the fan will turn off when the heater is on, which may result in fire.**

9-4. PAC-YU25HT (OPTIONAL PARTS) INSTALLATION

The following section describes installation of the External Heater Adapter that connects to PEAD-A-AA8 series indoor unit. This products is the special wiring parts to drive an electric heater with the air conditioner.

(1) Parts list

◆Check that the following parts are included in the package.

- 1) External output cable (with a yellow connector).....2 in total
Two types of cables with different connectors are included.
- 2) Panel heater connector..... 3 in total
White: 1
Green: 2 (2 types)

(2) Connection to the indoor unit

◆Use the cables that fit the connectors on the indoor unit control board.

- 1) External output cable (with a yellow connector)
This cable is used to connect a relay circuit for an interlocked operation with either an electric or a panel heater. Connect the cable to CN24 on the indoor unit control board.
- 2) Panel heater connector (with a white connector)
This connector is used to perform an interlocked operation with a panel heater. Depending on the indoor unit control board specification, connect the cable to CN4Y as appropriate

<Image>

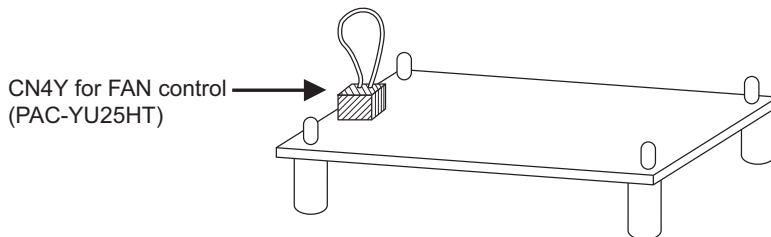

(3) Locally procured wiring

◆A basic connection method is shown below.

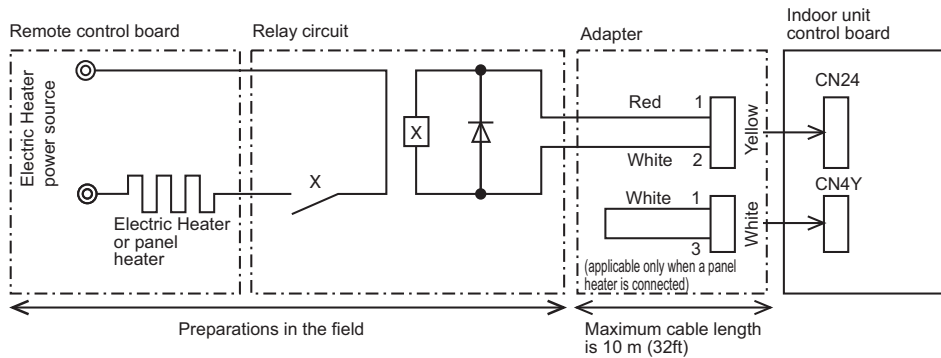

◆For relay X use the specifications given below Operation coil

Rated voltage: 12VDC

Power consumption: 0.9W or less

* Use the diode that is recommended by the relay manufacturer at both ends of the relay coil.

◆The length of the electrical wiring for the PAC-YU25HT is 2 meters (6-1/2 ft.)

◆To extend this length, use sheathed 2-core cable.

Control cable type: CVV, CVS, CPEV or equivalent.

Cable size: 0.5 mm² ~ 1.25 mm² (16 to 22 AWG)

Don't extend the cable more than 10 meters (32ft)

Recommended circuit

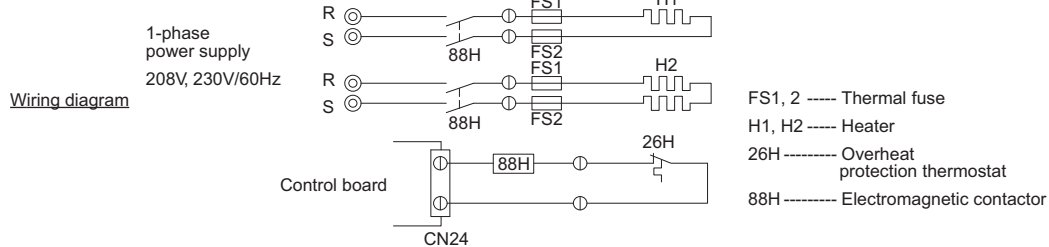

(4) Wiring restrictions

◆Keep the length of the cable connecting to the circuit board of the indoor unit shorter than 10 meters (32ft).

◆Longer than 10 meters (32ft) could cause improper operation.

◆Use a transit relay when extending wiring such as remote wiring.

10. HUMIDIFIER CONTROL

10-1. Control Specifications

The below table shows how the field installed humidifier and fan speed is controlled.

Mode (function) No.		Humidistat output	Condition (no defrost/no error)	CN25 output	Fan speed
Wired remote controller (RF thermostat)					
13 (113)	16 (116)	CNF input			
2	1	OFF	Heat operation & Thermo OFF	OFF	RC setting
			Heat operation & Thermo ON		
	ON	Heat operation & Thermo OFF	OFF	RC setting	
		Heat operation & Thermo ON	ON	High	
	2	OFF	Heat operation & Thermo OFF	OFF	RC setting
			Heat operation & Thermo ON		
ON	Heat operation & Thermo OFF	ON	High		
	Heat operation & Thermo ON				
1	-	-	Heat operation & Thermo OFF	OFF	RC setting
			Heat operation & Thermo ON	OFF	RC setting
-	-	-	Except for heat operation	OFF	RC setting

RC:Remote controller

The fan continues to run for 30 seconds after the humidifier stops.

10-2. Installation

A basic connection method is shown below.

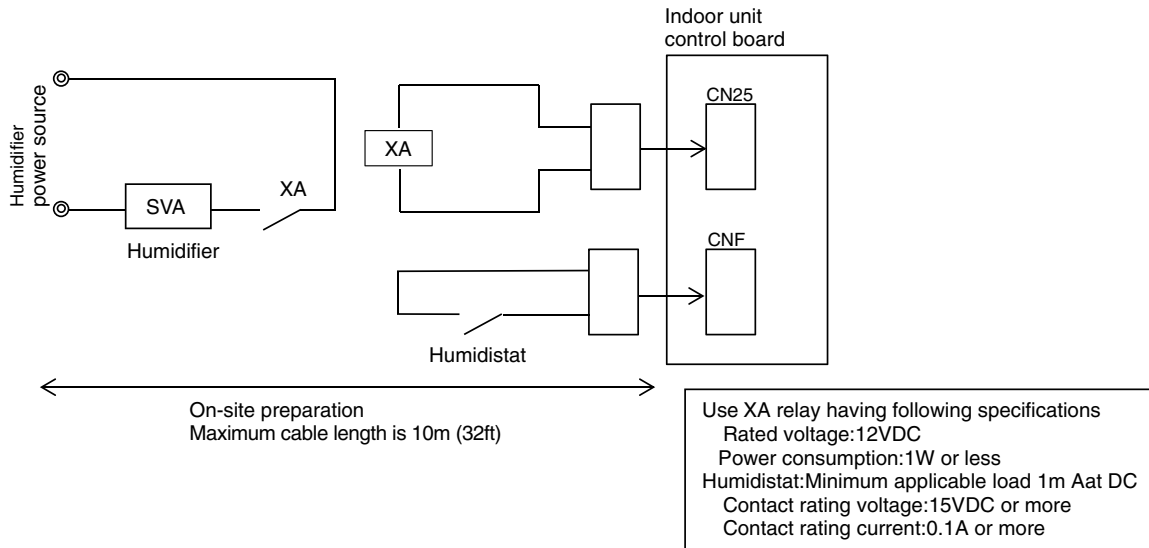

11. ERV (ENERGY RECOVERY VENTILATION) CONTROL

11-1. Control Specifications

The below table show how the field installed ERV is controlled.

ERV output CNER input	Function Mode26	Condition	Fan speed	CN2C output (=Fan output)
OFF	-	Cool/Heat/Fan operation	RC setting	ON
		Defrost	STOP	OFF
		STOP	STOP	OFF
ON	"1" ^{*1}	Cool/Heat/Fan operation	RC setting	ON
		Defrost	STOP	OFF
		STOP	STOP	OFF
	"2"	Cool/Heat/Fan operation	RC setting	ON
		STOP	RC setting ^{*2, *3}	ON

*1 Factory setting.

*2 When fan speed setting by RC is "Auto", Fan speed is fixed to "HIGH".

*3 If ERV control is effective when STOP, IDU doesn't report fan status or PB error (Fan motor error).

RC: Remote controller

11-2. Installation

A basic connection method is shown below.

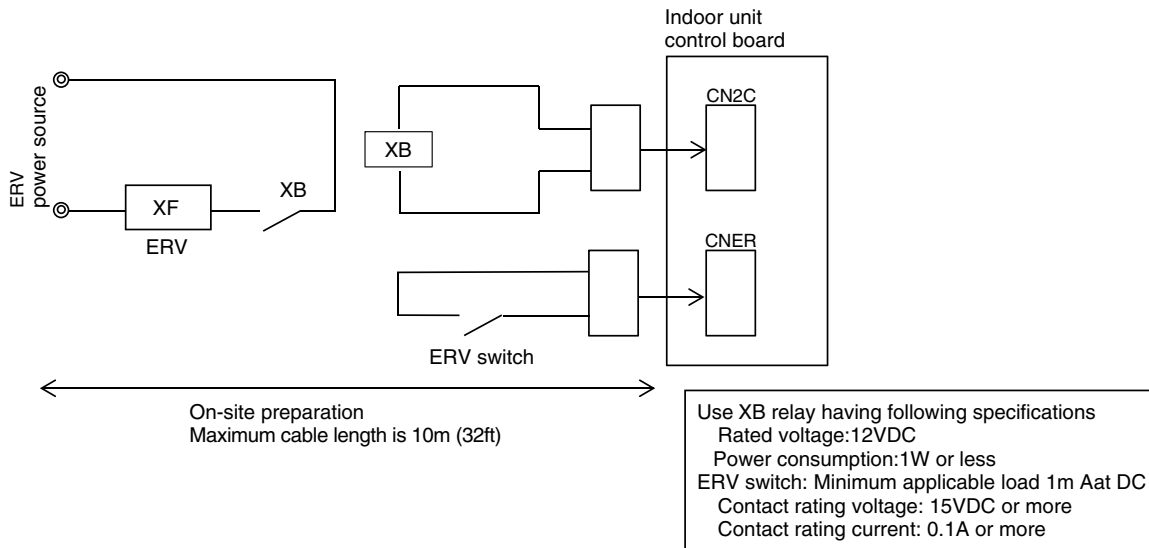

12. TROUBLESHOOTING

12-1. CAUTIONS ON TROUBLESHOOTING

(1) Before troubleshooting, check the followings:

- 1 Check the power supply voltage.
- 2 Check the indoor/outdoor connecting wire for mis-wiring.

(2) Take care the followings during servicing.

- 1 Before servicing the air conditioner, be sure to turn off the remote controller first to stop the main unit, and then turn off the breaker.
- 2 When removing the indoor controller board, hold the edge of the board with care NOT to apply stress on the components.
- 3 When connecting or disconnecting the connectors, hold the housing of the connector. DO NOT pull the lead wires.

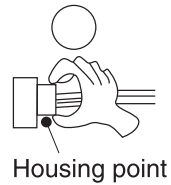
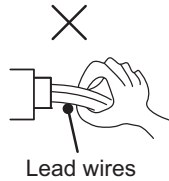

12-2. SELF-CHECK FUNCTION

- Refer to the installation manual that comes with each remote controller for details.
- RF thermostat is not established.

[Output pattern A] Errors detected by indoor unit

IR wireless remote controller	Wired remote controller RF thermostat	Symptom	Remark
Beeper sounds/OPERATION INDICATOR lamp flashes (Number of times)	Check code		
1	P1	Intake sensor error	
2	P2, P9	Pipe (Liquid or 2-phase pipe) sensor error	
3	E6, E7	Indoor/outdoor unit communication error	
4	P4	Drain sensor error	
5	P5	Drain pump error	
6	P6	Freezing/Overheating safeguard operation	
7	EE	Communication error between indoor and outdoor units	
8	P8	Pipe temperature error	
9	E4	Remote controller signal receiving error	
10	–	–	
11	–	–	
12	Fb	Indoor unit control system error (memory error, etc.)	
No sound	– –	No corresponding	

[Output pattern B] Errors detected by unit other than indoor unit (outdoor unit, etc.)

IR wireless remote controller	Wired remote controller RF thermostat	Symptom	Remark
Beeper sounds/OPERATION INDICATOR lamp flashes (Number of times)	Check code		
1	E9	Indoor/outdoor unit communication error (Transmitting error) (Outdoor unit)	For details, check the LED display of the outdoor controller board.
2	UP	Compressor overcurrent interruption	
3	U3, U4	Open/short of outdoor unit thermistors	
4	UF	Compressor overcurrent interruption (When compressor locked)	
5	U2	Abnormal high discharging temperature/49C worked/ insufficient refrigerant	
6	U1, Ud	Abnormal high pressure (63H worked)/ Overheating safeguard operation	
7	U5	Abnormal temperature of heat sink	
8	U8	Outdoor unit fan protection stop	
9	U6	Compressor overcurrent interruption/Abnormal of power module	
10	U7	Abnormality of super heat due to low discharge temperature	
11	U9, UH	Abnormality such as overvoltage or voltage shortage and abnormal synchronous signal to main circuit/Current sensor error	
12	–	–	
13	–	–	
14	Others	Other errors (Refer to the technical manual for the outdoor unit.)	

***1 If the beeper does not sound again after the initial two beeps to confirm the self-check start signal was received and the OPERATION INDICATOR lamp does not come on, there are no error records.**

***2 If the beeper sounds three times continuously “beep, beep, beep (0.4 + 0.4 + 0.4 sec.)” after the initial two beeps to confirm the self-check start signal was received, the specified refrigerant address is incorrect.**

- On IR wireless remote controller
The continuous buzzer sounds from receiving section of indoor unit.
Blink of operation lamp
- On wired remote controller
Check code displayed on the LCD.

- If the unit cannot be operated properly after the test run has been performed, refer to the following table to remove the cause.

Symptom		LED 1, 2 (PCB in outdoor unit)	Cause
Wired remote controller			
PLEASE WAIT	For about 2 minutes following power-on	After LED 1, 2 are lighted, LED 2 is turned off, then only LED 1 is lighted. (Correct operation)	<ul style="list-style-type: none"> • For about 2 minutes after power-on, operation of the remote controller is not possible due to system start-up. (Correct operation)
PLEASE WAIT → Error code	After about 2 minutes has expired	Only LED 1 is lighted. → LED 1, 2 blink.	<ul style="list-style-type: none"> • Connector for the outdoor unit's protection device is not connected. • Reverse or open phase wiring for the outdoor unit's power terminal block (L1, L2, L3)
Display messages do not appear even when operation switch is turned ON (operation lamp does not light up).	following power-on	Only LED 1 is lighted. → LED 1, 2 blinks twice, LED 2 blinks once.	<ul style="list-style-type: none"> • Incorrect wiring between indoor and outdoor units (incorrect polarity of S1, S2, S3) • Remote controller wire short

On the IR wireless remote controller with conditions above, following phenomena takes place.

- No signals from the remote controller are accepted.
- OPE lamp is blinking.
- The buzzer makes a short ping sound.

Note:

Operation is not possible for about 30 seconds after cancellation of function selection. (Correct operation)

For description of each LED (LED1, 2, 3) provided on the indoor controller, refer to the following table.

LED1 (power for microcomputer)	Indicates whether control power is supplied. Make sure that this LED is always lit.
LED2 (power for remote controller)	Indicates whether power is supplied to the remote controller. This LED lights only in the case of the indoor unit which is connected to the outdoor unit refrigerant address "0".
LED3 (communication between indoor and outdoor units)	Indicates state of communication between the indoor and outdoor units. Make sure that this LED is always blinking.

AUTO RESTART FUNCTION

Indoor controller board

This model is equipped with the AUTO RESTART FUNCTION.

When the indoor unit is controlled with the remote controller, the operation mode, set temperature, and the fan speed are memorized by the indoor controller board.

The auto restart function sets to work the moment the power has restored after power failure, then, the unit will restart automatically.

Set the AUTO RESTART FUNCTION using the wireless remote controller. (Mode no.1).

12-3. SELF-DIAGNOSIS ACTION TABLE

Note: Refer to the manual of outdoor unit for the details of display such as F, U, and other E.

Error Code	Abnormal point and detection method	Cause	Countermeasure
P1	<p>Room temperature thermistor (TH1)</p> <ol style="list-style-type: none"> The unit is in three-minute resume prevention mode if short/open of thermistor is detected. Abnormal if the unit does not reset normally after three minutes. (The unit returns to normal operation, if it has normally reset.) Constantly detected during cooling, drying and heating operation Short: 90°C[194°F] or more Open: -40°C[-40°F] or less 	<ol style="list-style-type: none"> Defective thermistor characteristics Contact failure of connector (CN20) on the indoor controller board (Insert failure) Breaking of wire or contact failure of thermistor wiring Defective indoor controller board 	<ol style="list-style-type: none"> Check resistance value of thermistor. 0°C[32°F].....15.0kΩ 10°C[50°F].....9.6kΩ 20°C[68°F].....6.3kΩ 30°C[86°F].....4.3kΩ 40°C[104°F]...3.0kΩ If you put force on (draw or bend) the lead wire with measuring resistance value of thermistor breaking of wire or contact failure can be detected. Check contact failure of connector (CN20) on the indoor controller board. Refer to 12-5. Turn the power on again and check restart after inserting connector again. Check room temperature display on remote controller. Replace indoor controller board if there is abnormal difference with actual room temperature. <p>Turn the power off, and on again to operate after check.</p>
P2	<p>Pipe temperature thermistor/Liquid (TH2)</p> <ol style="list-style-type: none"> The unit is in three-minute resume prevention mode if short/open of thermistor is detected. Abnormal if the unit does not reset normally after three minutes. (The unit returns to normal operation, if it has normally reset.) Constantly detected during cooling, drying, and heating (except defrosting) operation. Short: 90°C[194°F] or more Open: -40°C[-40°F] or less 	<ol style="list-style-type: none"> Defective thermistor characteristics Contact failure of connector (CN44) on the indoor controller board (Insert failure) Breaking of wire or contact failure of thermistor wiring Defective refrigerant circuit is causing thermistor temperature of 90°C[194°F] or more or -40°C[-40°F] or less. Defective indoor controller board 	<ol style="list-style-type: none"> Check resistance value of thermistor. For characteristics, refer to (P1) above. Check contact failure of connector (CN44) on the indoor controller board. Refer to 12-5. Turn the power on again and check restart after inserting connector again. Check pipe <liquid> temperature with remote controller in test run mode. If pipe <liquid> temperature is extremely low (in cooling mode) or high (in heating mode), refrigerant circuit may have defective. Check pipe <liquid> temperature with remote controller in test run mode. If there is extreme difference with actual pipe <liquid> temperature, replace indoor controller board. <p>Turn the power off, and on again to operate after check.</p>
P4 (5701)	<p>Contact failure of drain float switch (CN4F)</p> <ol style="list-style-type: none"> Extract when the connector of drain float switch is disconnected. (3 and 4 of connector CN4F is not short-circuited.) Constantly detected during operation. 	<ol style="list-style-type: none"> Contact failure of connector (Insert failure) Defective indoor controller board 	<ol style="list-style-type: none"> Check contact failure of float switch connector. Turn the power on again and check after inserting connector again. Operate with connector (CN4F) short-circuited. Replace indoor controller board if abnormality reappears.
P5	<p>Drain overflow protection operation</p> <ol style="list-style-type: none"> Suspensive abnormality, if drain float switch is detected to be underwater for 1 minute and 30 seconds continuously with drain pump on. Turn off compressor and indoor fan. Drain pump is abnormal if the condition above is detected during suspensive abnormality. Constantly detected during drain pump operation. 	<ol style="list-style-type: none"> Malfunction of drain pump Defective drain Clogged drain pump Clogged drain pipe Defective drain float switch Catch of drain float switch or malfunction of moving parts cause drain float switch to be detected under water (Switch On) Defective indoor-controller board 	<ol style="list-style-type: none"> Check if drain-up machine works. Check drain function. Remove drain float switch connector CN4F and check if it is short (Switch On) with the moving part of float switch UP, or OPEN with the moving part of float switch down. Replace float switch if it is short with the moving part of float switch down. Replace indoor controller board if it is short-circuited between 3-4 of the drain float switch connector CN4F and abnormality reappears. <p>It is not abnormal if there is no problem about the above-mentioned 1~4. Turn the power off, and on again to operate after check.</p>

Error Code	Abnormal point and detection method	Cause	Countermeasure
P6	<p>Freezing/overheating protection is working</p> <p>1. Freezing protection (Cooling mode) The unit is in six-minute resume prevention mode if pipe <liquid or condenser/evaporator> temperature stays under $-15^{\circ}\text{C}[5^{\circ}\text{F}]$ for three minutes after the compressor started. Abnormal if it stays under $-15^{\circ}\text{C}[5^{\circ}\text{F}]$ for three minutes again within 16 minutes after six-minute resume prevention mode.</p> <p>2. Overheating protection (Heating mode) The units is in six-minute resume prevention mode if pipe <Liquid or condenser / evaporator> temperature is detected as over $70^{\circ}\text{C}[158^{\circ}\text{F}]$ after the compressor started. Abnormal if the temperature of over $70^{\circ}\text{C}[158^{\circ}\text{F}]$ is detected again within 10 minutes after six-minute resume prevention mode.</p>	<p>(Cooling or drying mode)</p> <ol style="list-style-type: none"> 1. Clogged filter (reduced airflow) 2. Short cycle of air path 3. Low-load (low temperature) operation beyond the tolerance range 4. Defective indoor fan motor <ul style="list-style-type: none"> • Fan motor is defective. • Indoor controller board is defective. 5. Defective outdoor fan control 6. Overcharge of refrigerant 7. Defective refrigerant circuit (clogs) <p>(Heating mode)</p> <ol style="list-style-type: none"> 1. Clogged filter (reduced airflow) 2. Short cycle of air path 3. Over-load (high temperature) operation beyond the tolerance range 4. Defective indoor fan motor <ul style="list-style-type: none"> • Fan motor is defective. • Indoor controller board is defective. 5. Defective outdoor fan control 6. Overcharge of refrigerant 7. Defective refrigerant circuit (clogs) 8. Bypass circuit of outdoor unit is defective. 	<p>(Cooling or drying mode)</p> <ol style="list-style-type: none"> 1. Check clogging of the filter. 2. Remove shields. 4. Refer to 12-8. DC FAN MOTOR (FAN MOTOR/ INDOOR CONTROLLER BOARD) 5. Check outdoor fan motor. 6. 7. Check operating condition of refrigerant circuit. <p>(Heating mode)</p> <ol style="list-style-type: none"> 1. Check clogs of the filter. 2. Remove shields. 4. Refer to 12-8. DC FAN MOTOR (FAN MOTOR/ INDOOR CONTROLLER BOARD) 5. Check outdoor fan motor. 6~8. Check operating condition of refrigerant circuit.
P8	<p>Pipe temperature <Cooling mode> Detected as abnormal when the pipe temperature is not in the cooling range 3 minutes after compressor start and 6 minutes after the liquid or condenser/ evaporator pipe is out of cooling range. Note 1) It takes at least 9 minutes to detect. Note 2) Abnormality P8 is not detected in drying mode. Cooling range : $-3 \text{ deg}^{\circ}\text{C}(-5.4\text{deg}^{\circ}\text{F}) \geq (\text{TH}-\text{TH1})$ TH: Lower temperature between: liquid pipe temperature (TH2) and condenser/evaporator temperature (TH5) TH1: Intake temperature</p> <p><Heating mode> When 10 seconds have passed after the compressor starts operation and the hot adjustment mode has finished, the unit is detected as abnormal when condenser/ evaporator pipe temperature is not in heating range within 20 minutes.</p> <p>Note 3) It takes at least 27 minutes to detect abnormality. Note 4) It excludes the period of defrosting (Detection restarts when defrosting mode is over)</p> <p>Heating range : $3 \text{ deg}^{\circ}\text{C}(5.4\text{deg}^{\circ}\text{F}) \leq (\text{TH5}-\text{TH1})$</p>	<ol style="list-style-type: none"> 1. Slight temperature difference between indoor room temperature and pipe <liquid or condenser / evaporator> temperature thermistor <ul style="list-style-type: none"> • Shortage of refrigerant • Disconnected holder of pipe <liquid or condenser / evaporator> thermistor • Defective refrigerant circuit 2. Converse connection of extension pipe (on plural units connection) 3. Converse wiring of indoor/ outdoor unit connecting wire (on plural units connection) 4. Defective detection of indoor room temperature and pipe <condenser / evaporator> temperature thermistor 5. Stop valve is not opened completely. 	<ol style="list-style-type: none"> 1~4. Check pipe <liquid or condenser / evaporator> temperature with room temperature display on remote controller and outdoor controller circuit board. Pipe <liquid or condenser / evaporator> temperature display is indicated by setting SW2 of outdoor controller circuit board. <p>(Conduct temperature check with outdoor controller circuit board after connecting 'A-Control Service Tool (PAC-SK52ST)')</p> <ol style="list-style-type: none"> 2. 3. Check converse connection of extension pipe or converse wiring of indoor/outdoor unit connecting wire.

Error Code	Abnormal point and detection method	Cause	Countermeasure
pg	<p>Abnormality of pipe temperature thermistor / Condenser-Evaporator (TH5)</p> <ol style="list-style-type: none"> The unit is in three-minute resume protection mode if short/open of thermistor is detected. Abnormal if the unit does not get back to normal within three minutes. (The unit returns to normal operation, if it has normally reset.) Constantly detected during cooling, drying, and heating operation (except defrosting) Short: 90°C[194°F] or more Open: -40°C[-40°F] or less 	<ol style="list-style-type: none"> Defective thermistor characteristics Contact failure of connector (CN44) on the indoor controller board (Insert failure) Breaking of wire or contact failure of thermistor wiring Temperature of thermistor is 90°C[194°F] or more or -40°C[-40°F] or less caused by defective refrigerant circuit. Defective indoor controller board 	<ol style="list-style-type: none"> Check resistance value of thermistor. For characteristics, refer to (P1) above. Check contact failure of connector (CN44) on the indoor controller board. Refer to 12-5. Turn the power on and check restart after inserting connector again. Operate in test run mode and check pipe <condenser / evaporator> temperature. If pipe <condenser / evaporator> temperature is extremely low (in cooling mode) or high (in heating mode), refrigerant circuit may have defect. When no problems are found in 1-4 above, replace the indoor unit control board.
E0 or E4	<p>Remote controller transmission error(E0)/signal receiving error(E4)</p> <ol style="list-style-type: none"> Abnormal if main or sub remote controller can not receive normally any transmission from indoor unit of refrigerant address "0" for three minutes. (Error code : E0) Abnormal if sub remote controller could not receive for any signal for two minutes. (Error code: E0) <ol style="list-style-type: none"> Abnormal if indoor controller board can not receive normally any data from remote controller board or from other indoor controller board for three minutes. (Error code: E4) Indoor controller board cannot receive any signal from remote controller for two minutes. (Error code: E4) 	<ol style="list-style-type: none"> Contact failure at transmission wire of remote controller All remote controllers are set as "sub" remote controller. In this case, E0 is displayed on remote controller, and E4 is displayed at LED (LED1, LED2) on the outdoor controller circuit board. Mis-wiring of remote controller Defective transmitting receiving circuit of remote controller Defective transmitting receiving circuit of indoor controller board of refrigerant address "0" Noise has entered into the transmission wire of remote controller. 	<ol style="list-style-type: none"> Check disconnection or looseness of indoor unit or transmission wire of remote controller. Set one of the remote controllers "main". If there is no problem with the action above. Check wiring of remote controller. <ul style="list-style-type: none"> Total wiring length: max.500m (Do not use cable × 3 or more) The number of connecting indoor units: max.16units The number of connecting remote controller: max.2units <p>When it is not the above-mentioned problem of 1~3</p> <ol style="list-style-type: none"> Diagnose remote controllers. <ol style="list-style-type: none"> When "RC OK" is displayed, Remote controllers have no problem. Turn the power off, and on again to check. If abnormality generates again, replace indoor controller board. When "RC NG" is displayed, Replace remote controller. When "RC E3" is displayed, When "ERC 00-06" is displayed, <p>[c),d)→Noise may be causing abnormality.] * If the unit is not normal after replacing indoor controller board in group control, indoor controller board of address "0" may be abnormal.</p>
E3 or E5	<p>Remote controller transmission error(E3)/signal receiving error(E5)</p> <ol style="list-style-type: none"> Abnormal if remote controller could not find blank of transmission path for six seconds and could not transmit. (Error code: E3) Remote controller receives transmitted data at the same time, compares the data, and when detecting it, judges different data to be abnormal 30 continuous times. (Error code: E3) <ol style="list-style-type: none"> Abnormal if indoor controller board could not find blank of transmission path. (Error code: E5) Indoor controller board receives transmitted data at the same time, compares the data, and when detecting it, judges different data to be abnormal 30 continuous times. (Error code: E5) 	<ol style="list-style-type: none"> Two remote controllers are set as "main." (In case of 2 remote controllers) Remote controller is connected with two indoor units or more. Repetition of refrigerant address Defective transmitting receiving circuit of remote controller Defective transmitting receiving circuit of indoor controller board Noise has entered into transmission wire of remote controller. 	<ol style="list-style-type: none"> Set a remote controller to main, and the other to sub. Remote controller is connected with only one indoor unit. The address changes to a separate setting. <ol style="list-style-type: none"> Diagnose remote controller. <ol style="list-style-type: none"> When "RC OK" is displayed, remote controllers have no problem. Turn the power off, and on again to check. When becoming abnormal again, replace indoor controller board. When "RC NG" is displayed, replace remote controller. When "RC E3" or "ERC 00-66" is displayed, noise may be causing abnormality.

Error Code	Abnormal point and detection method	Cause	Countermeasure
E6	<p>Indoor/outdoor unit communication error (Signal receiving error)</p> <p>1. Abnormal if indoor controller board cannot receive any signal normally for six minutes after turning the power on.</p> <p>2. Abnormal if indoor controller board cannot receive any signal normally for three minutes.</p> <p>3. Consider the unit as abnormal under the following condition: When two or more indoor units are connected to an outdoor unit, indoor controller board cannot receive a signal for three minutes from outdoor controller circuit board, a signal which allows outdoor controller circuit board to transmit signals.</p>	<p>1. Contact failure, short circuit or, mis-wiring (converse wiring) of indoor/outdoor unit connecting wire</p> <p>2. Defective transmitting receiving circuit of indoor controller board</p> <p>3. Defective transmitting receiving circuit of indoor controller board</p> <p>4. Noise has entered into indoor/outdoor unit connecting wire.</p>	<p>* Check LED display on the outdoor control circuit board. (Connect A-control service tool, PAC-SK52ST.) Refer to EA-EC item of the service manual of outdoor unit if LED displays EA-EC.</p> <p>1. Check disconnection or looseness of indoor/outdoor unit connecting wire of indoor unit or outdoor unit. Check all the units in case of twin triple indoor unit system.</p> <p>2-4. Turn the power off, and on again to check. If abnormality generates again, replace indoor controller board or outdoor controller circuit board.</p> <p>* Other indoor controller board may have defect in case of twin triple indoor unit system.</p>
E7	<p>Indoor/outdoor unit communication error (Transmitting error)</p> <p>Abnormal if "1" receiving is detected 30 times continuously though indoor controller board has transmitted "0".</p>	<p>1. Defective transmitting receiving circuit of indoor controller board</p> <p>2. Noise has entered into power supply.</p> <p>3. Noise has entered into outdoor control wire.</p>	<p>1-3. Turn the power off, and on again to check. If abnormality generates again, replace indoor controller board.</p>
Fb	<p>Indoor controller board</p> <p>Abnormal if data cannot be read normally from the nonvolatile memory of the indoor controller board.</p>	<p>1. Defective indoor controller board</p>	<p>1. Replace indoor controller board.</p>
E1 or E2	<p>Remote controller control board</p> <p>1. Abnormal if data cannot be read normally from the nonvolatile memory of the remote controller control board. (Error code: E1)</p> <p>2. Abnormal if the clock function of remote controller cannot be operated normally. (Error code: E2)</p>	<p>1. Defective remote controller</p>	<p>1. Replace remote controller.</p>
PA (2500)	<p>Water leakage</p> <p>This detection is performed during the operation (stop, heating, fan, or error stop mode etc.) other than cooling and dry.</p> <p>1. When a) and b) are found, water leakage occurs.</p> <p>a) Pipe <liquid> temperature - inlet temperature < -10°C for 30 minutes</p> <p>b) When drain float switch is detected to be soaked in the water for 15 minutes or more.</p> <p>* When drain float switch is detected to be NOT soaked in the water, each counting of a) and b) is cleared.</p> <p><u>*When this error is detected, the error will not be reset until the main power is reset.</u></p>	<p>1. Mis-piping of extension pipes (When connected with multiple units)</p> <p>2. Mis-wiring of indoor/outdoor unit connecting wire (When connected with multiple units)</p> <p>3. Detection failure of the indoor unit inlet/pipe <liquid> thermistor</p> <p>4. Drain pump failure</p> <p>5. Drainage failure</p> <ul style="list-style-type: none"> • Clogged drain pump • Clogged drain pipe <p>6. Drain float switch failure</p> <ul style="list-style-type: none"> • Drain float switch is detected to be soaked in the water (ON status) due to the operation failure of the moving parts. • Contact failure of drain float switch connector (Loose connector) 	<p>1. Check the extension pipes for mis-piping.</p> <p>2. Check the Indoor/outdoor unit connecting wire for mis-wiring.</p> <p>3. Check room temperature display on remote controller and indoor pipe <liquid> temperature. (Refer to the countermeasure on P2.)</p> <p>4. Check if drain-up machine works.</p> <p>5. Check drain function.</p> <p>6. Check drain float switch. (Refer to the countermeasure on P4 and P5.)</p>

12-4. TROUBLESHOOTING BY INFERIOR PHENOMENA

Note: Refer to the manual of outdoor unit for the detail of remote controller.

Phenomena	Cause	Countermeasure
<p>(1)LED2 on indoor controller board is off.</p>	<ul style="list-style-type: none"> • When LED1 on indoor controller board is also off. <ol style="list-style-type: none"> 1. Power supply of rated voltage is not supplied to outdoor unit. 2. Defective outdoor controller circuit board 3. Power supply of 208~230V is not supplied to indoor unit. 4. Defective indoor controller board 	<ol style="list-style-type: none"> 1. Check the voltage of outdoor power supply terminal block (L,N) or (L₃,N). <ul style="list-style-type: none"> • When AC 208~230V is not detected. Check the power wiring to outdoor unit and the breaker. • When AC 208~230V is detected. —Check 2 (below). 2. Check the voltage between outdoor terminal block S1 and S2. <ul style="list-style-type: none"> • When AC 208~230V is not detected. Check the fuse on outdoor controller circuit board. Check the wiring connection. • When AC 208~230V is detected. —Check 3 (below). 3. Check the voltage between indoor terminal block S1 and S2. <ul style="list-style-type: none"> • When AC 208~230V is not detected. Check indoor/outdoor unit connecting wire for mis-wiring. • When AC 208~230V is detected. —Check 4 (below). 4. Check the fuse on indoor controller board. Check the wiring connection. If no problem are found, indoor controller board is defective.
<p>(2)LED2 on indoor controller board is blinking.</p>	<ul style="list-style-type: none"> • When LED1 on indoor controller board is also blinking. • Connection failure of indoor/outdoor unit connecting wire • When LED1 is lit. <ol style="list-style-type: none"> 1. Mis-wiring of remote controller wires Under twin triple indoor unit system, 2 or more indoor units are wired together. 2. Refrigerant address for outdoor unit is wrong or not set. Under grouping control system, there are some units whose refrigerant address is 0. 3. Short-cut of remote controller wires 4. Defective remote controller 	<p>Check indoor/outdoor unit connecting wire for connection failure.</p> <ol style="list-style-type: none"> 1. Check the connection of remote controller wires in case of twin triple indoor unit system. When 2 or more indoor units are wired in one refrigerant system, connect remote controller wires to one of those units. 2. Check the setting of refrigerant address in case of grouping control system. If there are some units whose refrigerant addresses are 0 in one group, set one of the units to 0 using SW1 (3-6) on outdoor controller circuit board. 3. 4. Remove remote controller wires and check LED2 on indoor controller board. <ul style="list-style-type: none"> • When LED2 is blinking, check the short-cut of remote controller wires. • When LED2 is lit, connect remote controller wires again and: if LED2 is blinking, remote controller is defective; if LED2 is lit, connection failure of remote controller terminal block etc. has returned to normal.

12-5. TEST POINT DIAGRAM

12-5-1. Power supply board

- PEAD-A09AA8
- PEAD-A12AA8
- PEAD-A15AA8
- PEAD-A18AA8
- PEAD-A24AA8
- PEAD-A30AA8
- PEAD-A36AA8
- PEAD-A42AA8

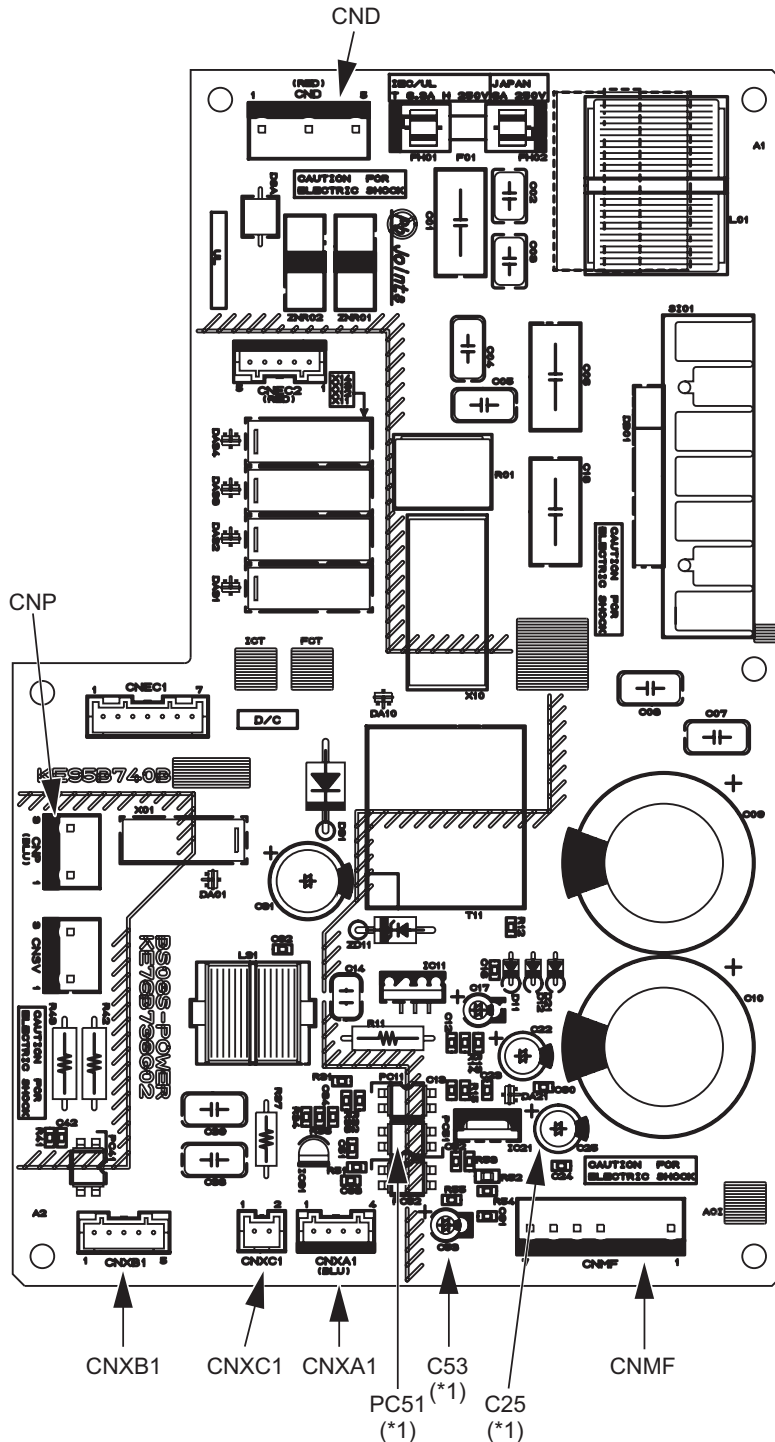

CND Power supply voltage (208 - 230VAC)

CNMF Fan motor output
 1 - 4: 310 - 340 VDC
 5 - 4: 15 VDC
 6 - 4: 0 - 6.5 VDC
 7 - 4: Stop 0 or 15 VDC
 Run 7.5 VDC
 (0 - 15 pulse)

CNP Drain-up mechanism output
 (208 - 230VAC)

CNXA1 Connect to the indoor controller board

CNXB1 Connect to the indoor controller board

CNXC1 Connect to the indoor controller board

CNXA2 Connect to the indoor power board

CNXB2 Connect to the indoor power board

CNXC2 Connect to the indoor power board

(*1)

V_{FG} Voltage on the (-) side of PC51 and C25
 (Same with the voltage between 7 (+) and 4 (-) of CNMF)

V_{CC} Voltage between the C25 pins 15 VDC
 (Same with the voltage between 5 (+) and 4 (-) of CNMF)

V_{sp} Voltage between the C53 pins 0VDC
 (with the fan stopped)
 1 - 6.5VDC (with the fan in operation)
 (Same with the voltage between 6 (+) and 4 (-) of CNMF)

12-5-2. Indoor controller board

PEAD-A09AA8
 PEAD-A12AA8
 PEAD-A15AA8
 PEAD-A18AA8
 PEAD-A24AA8
 PEAD-A30AA8
 PEAD-A36AA8
 PEAD-A42AA8

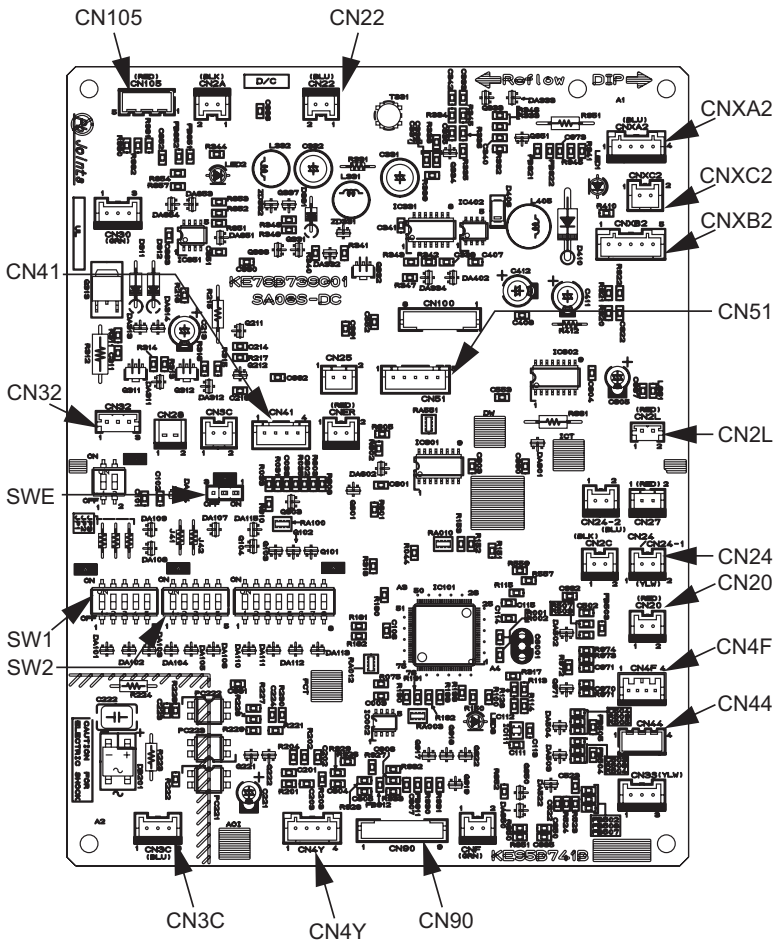

- SWE Emergency operation
- SW1 Model selection
- SW2 Capacity setting
- CN105 Radio frequency interface
- CN32 Remote start/stop adapter
- CN22 For MA remote controller cabel connection (10 - 13 VDC (Between 1 and 3.))
- CN51 Centralized control
- CN41 JAMA standard HA terminal A
- CN44 Thermistor (liquid/condenser/evaporator temperature)
- CN4F Float thermistor
- CN20 Thermistor (Inlet temperature)
- CN24 Heater control (12VDC)
- CN4Y For fan control
- CN3C Indoor-outdoor transmission (0 - 24VDC)
- CN90 Wireless remote controlelr
- CNXA2 Connect to the indoor controller board
- CNXB2 Connect to the indoor controller board
- CNXC2 Connect to the indoor controller board
- CNXA1 Connect to the indoor power board
- CNXB1 Connect to the indoor power board
- CNXC1 Connect to the indoor power board

12-6. TROUBLE CRITERION OF MAIN PARTS

- PEAD-A09AA8
- PEAD-A12AA8
- PEAD-A15AA8
- PEAD-A18AA8
- PEAD-A24AA8
- PEAD-A30AA8
- PEAD-A36AA8
- PEAD-A42AA8

Part name	Check method and criterion					
Room temperature thermistor (TH1)	Measure the resistance with a tester. (Part temperature 10°C (50°F) ~ 30°C (86°F)) <table border="1" style="margin: 10px auto; border-collapse: collapse;"> <thead> <tr> <th style="width: 50%;">Normal</th> <th style="width: 50%;">Abnormal</th> </tr> </thead> <tbody> <tr> <td style="text-align: center;">4.3kΩ~9.6kΩ</td> <td style="text-align: center;">Opened or short-circuited</td> </tr> </tbody> </table>		Normal	Abnormal	4.3kΩ~9.6kΩ	Opened or short-circuited
Normal			Abnormal			
4.3kΩ~9.6kΩ			Opened or short-circuited			
Pipe temperature thermistor/liquid (TH2)						
Condenser/evaporator temperature thermistor (TH5)						

12-7. Thermistor

<Thermistor Characteristic graph>

Thermistor for lower temperature

Room temperature thermistor (TH1)
 Pipe temperature thermistor (TH2)
 Condenser/evaporator temperature thermistor (TH5)

Thermistor $R_0=15k\Omega \pm 3\%$
 Fixed number of $B=3480k\Omega \pm 2\%$

$$R_t = 15 \exp \left\{ 3480 \left(\frac{1}{273+t} - \frac{1}{273} \right) \right\}$$

0°C	(32°F)	15kΩ
10°C	(50°F)	9.6kΩ
20°C	(68°F)	6.3kΩ
25°C	(77°F)	5.2kΩ
30°C	(86°F)	4.3kΩ
40°C	(104°F)	3.0kΩ

< Thermistor for lower temperature >

12-8. DC FAN MOTOR (FAN MOTOR/INDOOR CONTROLLER BOARD)

1. CAUTION

- A high voltage is applied to the connector for connection to the fan motor (CNMF).
- Do not unplug the connector CNMF with the unit energized to avoid damage to the indoor control board and fan motor.

2. Troubleshooting

- Symptom: Indoor unit fan does not run.

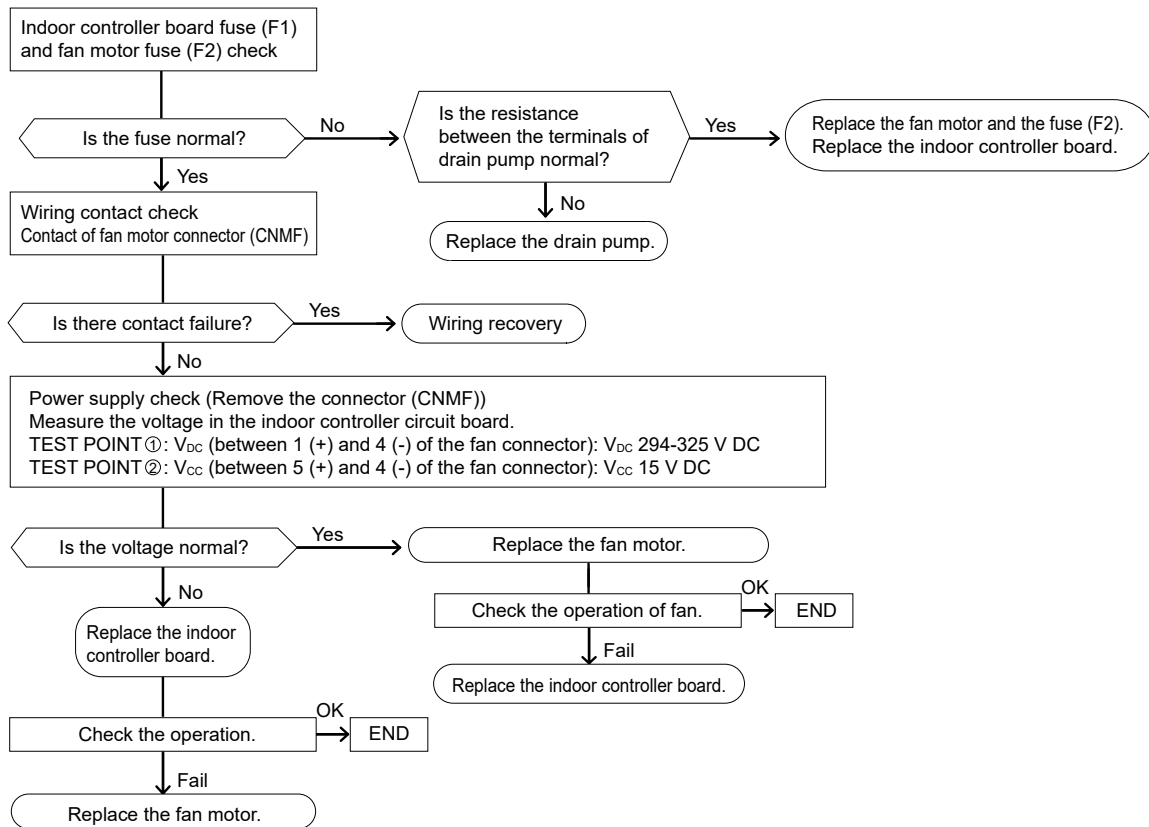











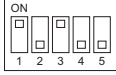

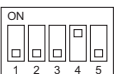

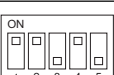
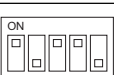

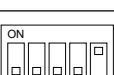

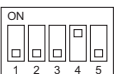
12-9. FUNCTIONS OF DIP SWITCH AND JUMPER WIRE

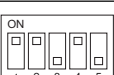
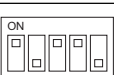
Each function is controlled by the dip switch and the jumper wire on control p.c. board.

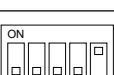
SW1 and SW2 are equipped only for service parts.

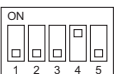
Model setting and capacity setting are memorized in the nonvolatile memory of the control p.c. board of the unit.

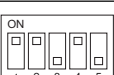
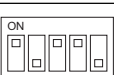
(Marks in the table below) Jumper wire (○: Short ×: Open)

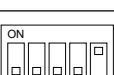
Jumper wire	Functions	Setting by the dip switch and jumper wire	Remarks																		
SW1	Model settings	For service board 																			
SW2	Capacity settings	<table border="1"> <thead> <tr> <th>MODELS</th> <th>Service board</th> </tr> </thead> <tbody> <tr> <td>PEAD-A09AA8</td> <td></td> </tr> <tr> <td>PEAD-A12AA8</td> <td></td> </tr> <tr> <td>PEAD-A15AA8</td> <td></td> </tr> <tr> <td>PEAD-A18AA8</td> <td></td> </tr> <tr> <td>PEAD-A24AA8</td> <td></td> </tr> <tr> <td>PEAD-A30AA8</td> <td></td> </tr> <tr> <td>PEAD-A36AA8</td> <td></td> </tr> <tr> <td>PEAD-A42AA8</td> <td></td> </tr> </tbody> </table>	MODELS	Service board	PEAD-A09AA8		PEAD-A12AA8		PEAD-A15AA8		PEAD-A18AA8		PEAD-A24AA8		PEAD-A30AA8		PEAD-A36AA8		PEAD-A42AA8		
MODELS	Service board																				
PEAD-A09AA8																					
PEAD-A12AA8																					
PEAD-A15AA8																					
PEAD-A18AA8																					
PEAD-A24AA8																					
PEAD-A30AA8																					
PEAD-A36AA8																					
PEAD-A42AA8																					
J41 J42	Pair number setting with wireless remote controller	<table border="1"> <thead> <tr> <th rowspan="2">Wireless remote controller setting</th> <th colspan="2">Control PCB setting</th> </tr> <tr> <th>J41</th> <th>J42</th> </tr> </thead> <tbody> <tr> <td>0</td> <td>○</td> <td>○</td> </tr> <tr> <td>1</td> <td>×</td> <td>○</td> </tr> <tr> <td>2</td> <td>○</td> <td>×</td> </tr> <tr> <td>3 ~ 9</td> <td>×</td> <td>×</td> </tr> </tbody> </table>	Wireless remote controller setting	Control PCB setting		J41	J42	0	○	○	1	×	○	2	○	×	3 ~ 9	×	×	<p><Settings at time of factory shipment> Wireless remote controller: 0 Control PCB: ○ (for both J41 and J42) Four pair number settings are supported. The pair number settings of the wireless remote controller and indoor control PCB (J41/J42) are given in the table on the left. ('×' in the table indicates the jumper line is disconnected.)</p>	
Wireless remote controller setting	Control PCB setting																				
	J41	J42																			
0	○	○																			
1	×	○																			
2	○	×																			
3 ~ 9	×	×																			
JP1	Unit type setting	<table border="1"> <thead> <tr> <th>Model</th> <th>JP1</th> </tr> </thead> <tbody> <tr> <td>Without TH5</td> <td>○</td> </tr> <tr> <td>With TH5</td> <td>×</td> </tr> </tbody> </table>	Model	JP1	Without TH5	○	With TH5	×	There is no jumper (JP1) because these models have the cond./eva. temperature thermistor (TH5).												
Model	JP1																				
Without TH5	○																				
With TH5	×																				
JP3	Indoor controller board type setting	<table border="1"> <thead> <tr> <th>Indoor controller board type</th> <th>JP3</th> </tr> </thead> <tbody> <tr> <td>Factory shipment</td> <td>○</td> </tr> <tr> <td>Service parts</td> <td>○</td> </tr> </tbody> </table>	Indoor controller board type	JP3	Factory shipment	○	Service parts	○													
Indoor controller board type	JP3																				
Factory shipment	○																				
Service parts	○																				

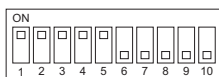

The figure at left shows that the switches 1 through 5 are set to ON and 6 through 10 are set to OFF.

13. DISASSEMBLY PROCEDURE

Exercise caution when removing heavy parts.

PEAD-A09AA8
 PEAD-A12AA8
 PEAD-A15AA8
 PEAD-A18AA8
 PEAD-A24AA8
 PEAD-A30AA8
 PEAD-A36AA8
 PEAD-A42AA8

1. Control box

1. Removing the control box cover
 - (1) Remove the three fixing screws on the cover (A) to remove it.
 - Tighten screws to a torque of 2.0 ± 0.2 N·m.

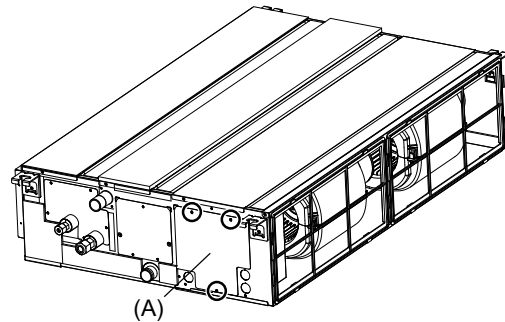

Fig. 1

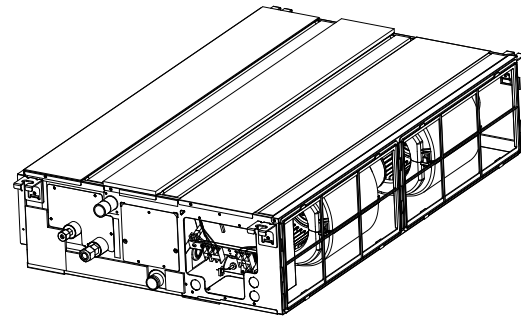

Fig. 2

2. Thermistor (Intake air)

1. Remove the control box cover according to the procedure in section 1.
 - (1) Pull out the thermistor holder (B) and thermistor (C) on the control box.

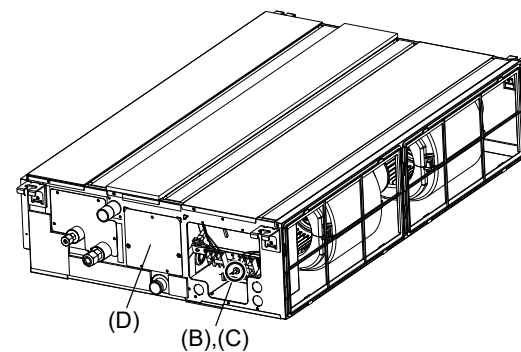

Fig. 3

Exercise caution when removing heavy parts.

3. Drain pump

1. Remove the control box cover according to the procedure in section 1.
2. Remove the drain pump.
 - (1) Remove the drain pump from connector (E) in control box.
 - (2) Remove the cover (D) and the drain pump.

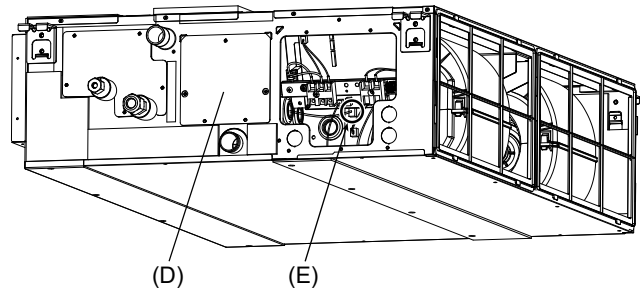

Fig. 4

4. Drainpan

1. Removing the filter and the bottom plate
 - (1) Push up the tab on the filter, and pull out the filter in the direction of the arrow 1.
 - (2) Remove the fixing screws on the bottom plate (F), (G) to remove it.
 - Tighten screws to a torque of $1.4 \pm 0.2 \text{ N}\cdot\text{m}$.

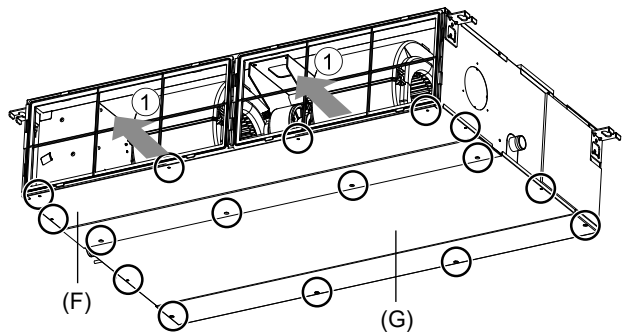

Fig. 5

2. Removing the drainpan
 - (1) Pull out the drain pan in the direction of the arrow 2.

Note

- Drain the water out of the drain pan before removing it.

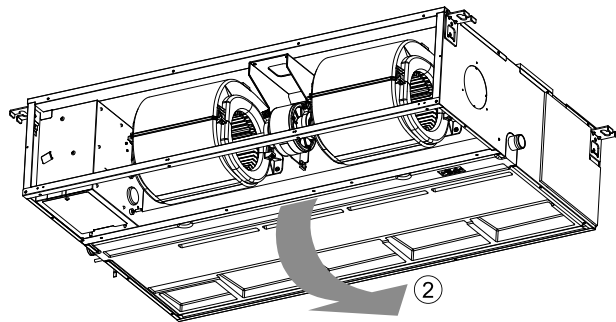

Fig. 6

5. Thermistor (Condenser/evaporator) (Liquid pipe)

1. Remove the drain pan according to the procedure in section 4.
2. Removing the Heat exchanger cover
 - (1) Remove the three fixing screws on the heat exchanger cover (H) to remove it.
 - Tighten screws to a torque of 1.4 ± 0.2 N·m.

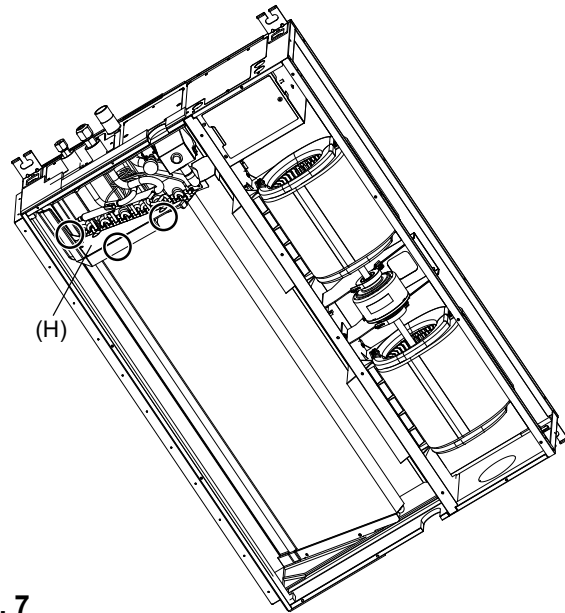

Fig. 7

3. Removing the thermistor
 - (1) Remove the thermistor (J) from the thermistor holder (K) on the copper tube.

Thermistor size
Liquid pipe: $\varnothing 8\text{mm}$
Condenser/evaporator: $\varnothing 6\text{mm}$

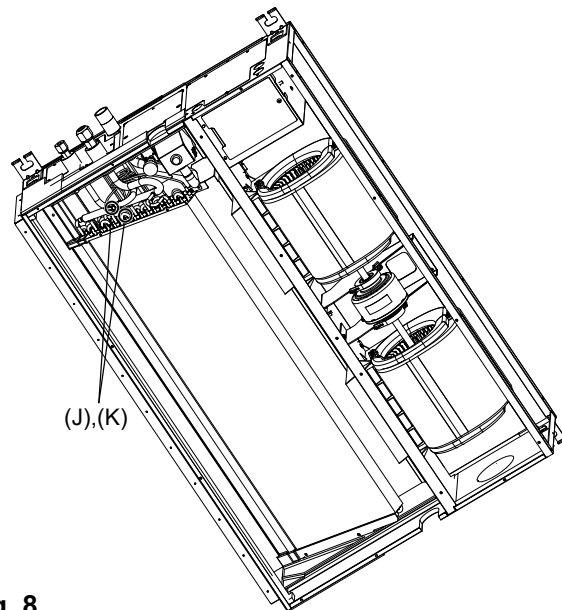

Fig. 8

6. Fan and fan motor

1. Removing the filter and the bottom plate

- (1) Push down the tab on the filter, and pull out the filter in the direction of the arrow 1.
- (2) Remove the fixing screws on the bottom plate (L) to remove it.
 - Tighten screws to a torque of 1.4 ± 0.2 N·m.

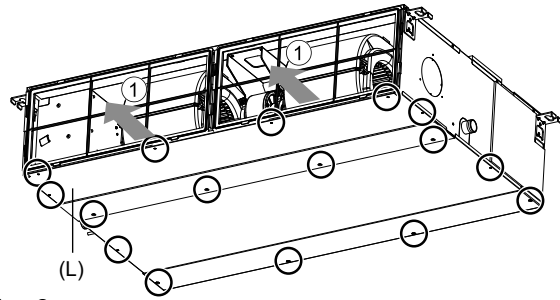

Fig. 9

2. Removing the fan casing (bottom half)

- (1) Squeeze the tabs (a) on the fan casing to remove it in the direction of arrow 2.

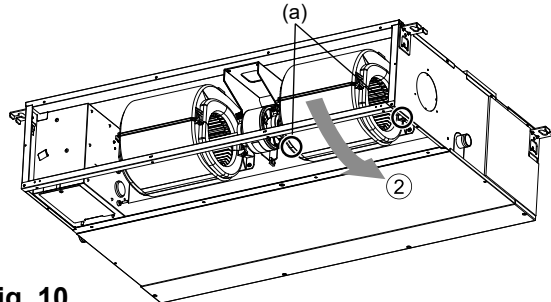

Fig. 10

3. Removing the motor cable

- (1) Remove the motor cable through the rubber bush.

4. Removing the fan motor and the Sirocco fan

- (1) Loosen either of the two rubber joint (M) fixing screws.
- (2) To remove the Sirocco fans (b) and (c) of PEAD-A36, 42AA8, loosen only the screw (d) on the bearing support (N), and remove the other screws on it.
- (3) Remove the two motor fixing screws to remove the motor and the Sirocco fan in the direction of arrow 3.
 - Tighten screws to a torque of 3.5 ± 0.2 N·m.

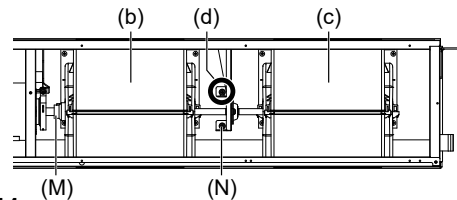

Fig. 11

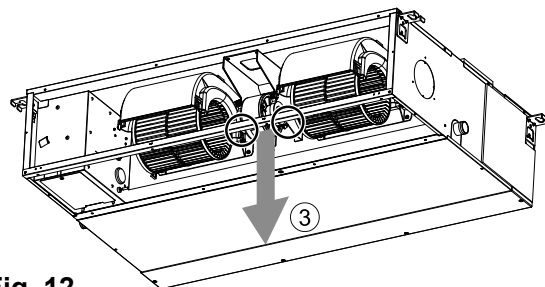

Fig. 12

- (4) Remove the four fan case fixing screws to take the top half of the fan casing off.
 - Tighten screws to a torque of 1.4 ± 0.2 N·m.

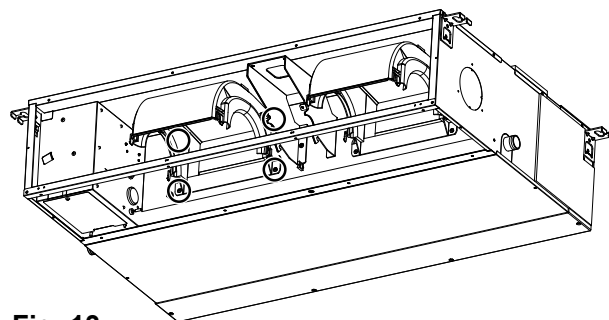
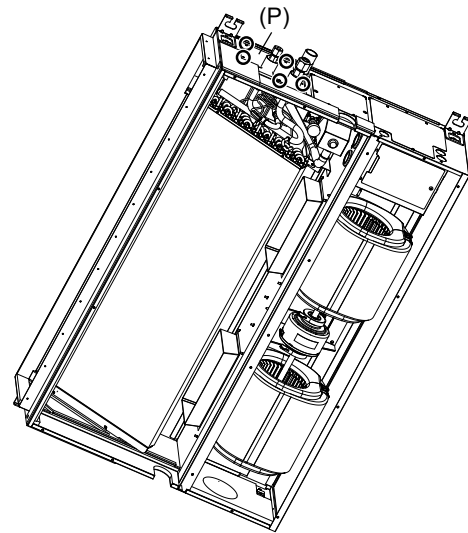

Fig. 13

Exercise caution when removing heavy parts.

7. Heat exchanger

1. Remove the drain pan according to the procedure in section 4.
2. Remove the heat exchanger cover according to the procedure in section 5.2.
3. Removing the cover
 - (1) Remove the five fixing screws on the cover (P) to remove it.
 - Tighten screws to a torque of 2.0 ± 0.2 N·m.

**Fig. 14**

4. Removing the Heat exchanger
 - (1) Remove the fixing screws on the heat exchanger (Q) to remove it.
 - Tighten screws to a torque of 1.4 ± 0.2 N·m.

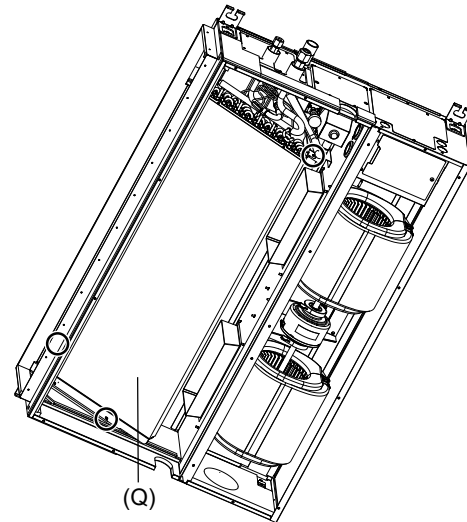
**Fig. 15**

mitsubishi electric corporation

www.MitsubishiElectric.com
