



Gas engine must be purchased separately.

FEATURES

- Triplex plunger design provides a smooth liquid flow.
- Specially formulated high pressure seals and concentric solid ceramic plungers assure true wear surface and extended seal life.
- Stacked valve design for ease in servicing.
- Ultra-compact, hollow-shafted pump for direct mounting to gas engine.
- Integral Pressure Unloader with built-in by-pass standard on all units to assure system pressure control and pump protection.
- Fixed chemical injector standard on all units offers cleaning flexibility.

⚠ CAUTIONS AND WARNINGS

All High Pressure Systems require a primary pressure regulating device (i.e. regulator, unloader) and a secondary pressure relief device (i.e. pop-off valve, relief valve). Failure to install such relief devices could result in personal injury or damage to pump or property. CAT PUMPS does not assume any liability or responsibility for the operation of a customer's high pressure system.

Read all CAUTIONS and WARNINGS before commencing service or operation of any high pressure system. The CAUTIONS and WARNINGS are included in each service manual and with each Accessory Data sheet. CAUTIONS and WARNINGS can also be viewed online at www.catpumps.com/cautions-warnings or can be requested directly from CAT PUMPS.

WARRANTY

View the Limited Warranty on-line at www.catpumps.com/warranty.

Direct-Drive Plunger Pumps

Models

4PPX25GSI 4PPX30GSI

SPECIFICATIONS

MODEL 4PPX25GSI

	U.S. Measure	Metric Measure
Flow.....	2.5 gpm	(9.5 lpm)
Maximum Discharge Pressure.....	3300 psi	(228 bar)
Maximum RPM.....	3450 rpm	(3450 rpm)
Stroke.....	0.268"	(6.8 mm)

MODEL 4PPX30GSI

Flow.....	2.7 gpm	(10.2 lpm)
Maximum Discharge Pressure.....	3000 psi	(310 bar)
Maximum RPM.....	3450 rpm	(3450 rpm)
Stroke.....	0.280"	(7.2 mm)

COMMON PUMP SPECIFICATIONS

Inlet Pressure Range.....	Flooded to 60 psi	(Flooded to 4 bar)
Bore.....	0.551"	(14 mm)
Crankcase Capacity.....	8.5 oz.	(0.25 l)
Maximum Liquid Temperature.....	140°F	(60°C)
Above 130°F call CAT PUMPS for inlet conditions and elastomer recommendations.		
Inlet Ports (1).....	3/8" NPTF	(3/8" NPTF)
Accessory Port (1) (Inlet).....	1/4" NPTF	(1/4" NPTF)
Discharge Port w/Chemical Injector (1).....	3/8" NPTM	(3/8" NPTM)
Chemical Injection Hose Barb.....	1/4"	(1/4")
Shaft Diameter (Hollow).....	3/4"	(19.0 mm)
Weight.....	10.7 lbs.	(4.9 kg)
Dimensions.....	8.03 x 7.83 x 6.61"	(204 x 199 x 168 mm)

ELECTRIC HORSEPOWER REQUIREMENTS

MODELS	FLOW		PRESSURE					RPM
			psi 1500	psi 2000	psi 2850	psi 3000	psi 3300	
	U.S. gpm	lpm	bar 105	bar 140	bar 196	bar 310	bar 228	
4PPX25GSI	2.5	9.5	2.6	3.4	4.9	5.1	5.6	3450
4PPX30GSI	2.7	10.2	2.8	3.7	5.3	5.5	6.1	3450

DETERMINING THE PUMP R.P.M.

$$\frac{\text{Rated gpm}}{\text{Rated rpm}} = \frac{\text{"Desired" gpm}}{\text{"Desired" rpm}}$$

DETERMINING THE REQUIRED H.P.

$$\frac{\text{gpm} \times \text{psi}}{1460} = \text{Electric Brake H. P. Required}$$

Refer to pump **Service Manual** for repair procedure and additional technical information.

EXPLODED VIEW

December 2012

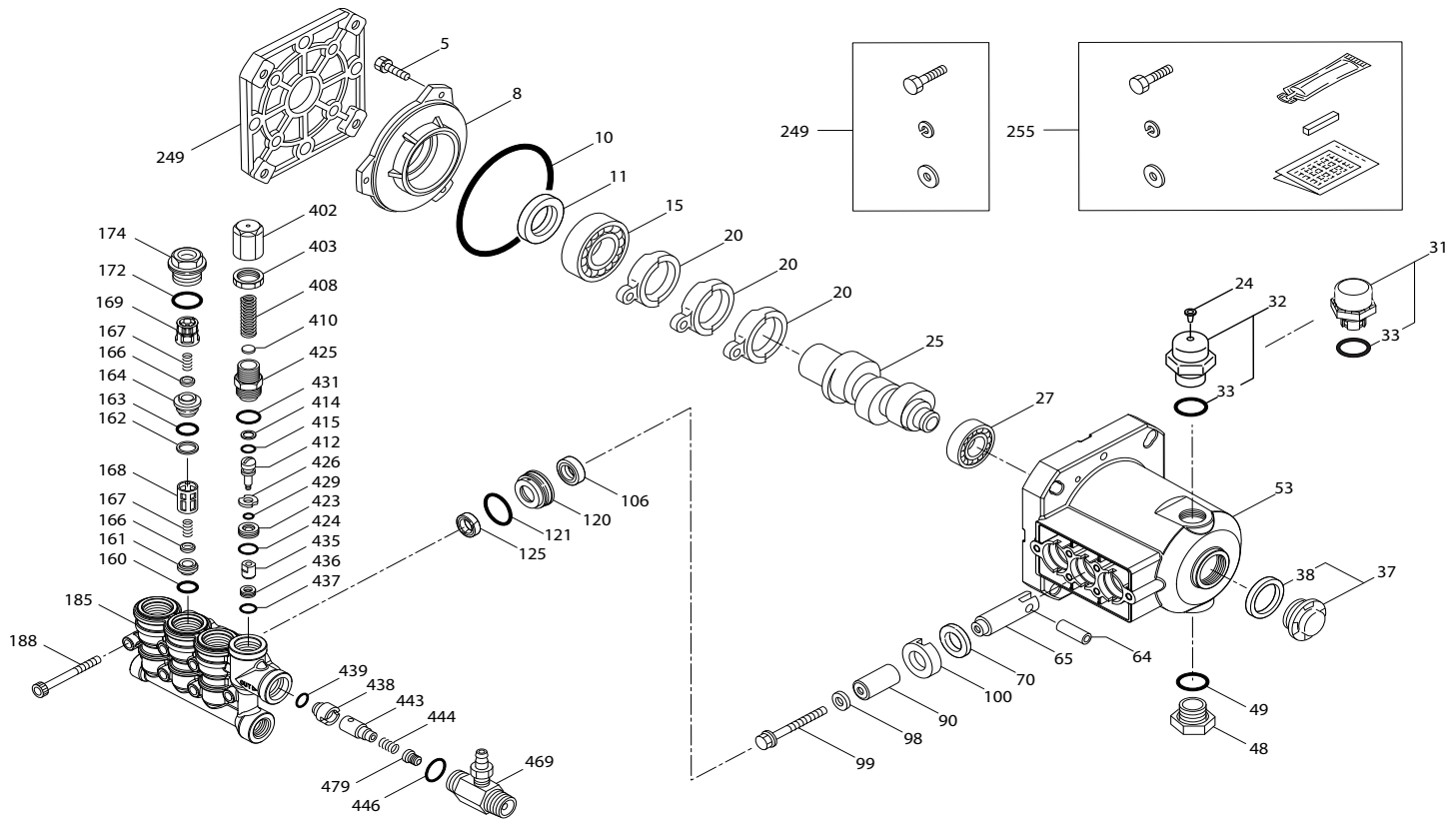

PLUNGER PUMP MODELS

4PPX25GSI, 4PPX30GSI

PARTS LIST

ITEM	P/N	MATL	DESCRIPTION	QTY	ITEM	P/N	MATL	DESCRIPTION	QTY
5	549360	STCP R	Screw, HH (M6x14)	3	106	49816	NBR	Seal, LPS	3
8	547153	AL	Cover, Bearing	1	120	49804	BB	Case, Seal	3
10	14041	NBR	O Ring, Bearing Cover 70D	1	121	13976	NBR	O Ring, Seal Case 70D	3
11	55337	NBR	Seal, Oil 70D	1	125	49824	BP	Seal, HPS	3
15	14488	STL	Bearing, Ball Inner	1	160	17428	NBR	O Ring, Inlet Seat 80D	3
20	547048	TNM	Rod, Connecting	3	161	547077	S	Seat, Inlet	3
24	549608	LDPE	Plug, Oil Cap	1	162	48361	D	Back up Ring, Discharge Seat	3
25	49883	CM	Crankshaft, 3450 RPM, 3/4", 6.8 mm (4PPX25GSI)	1	163	43358	NBR	O Ring, Discharge Seat 70D	3
	49882	CM	Crankshaft, 3450 RPM, 3/4", 7.2 mm (4PPX30GSI)	1	164	547076	S	Seat, Discharge	3
27	15710	STL	Bearing, Ball	1	166	547098	S	Valve	6
31	549726		Cap, Vented w/O Ring (Rain Cap)	1	167	46865	S	Spring	6
32	547961	RTP	Cap, Oil Filler w/O Ring	1	168	543988	PVDF	Retainer, Spring, Inlet	3
33	14179	NBR	O Ring, Oil Filler Cap 70D	1	169	49764	PVDF	Retainer, Spring, Discharge	3
37	92241		Gauge, Bubble Oil w/Gasket	1	172	142807	NBR	O Ring, Plug 90D	3
38	44428	NBR	Gasket, Flat Flex, Oil Gauge 80D	1	174	547104	BB	Plug, Valve w/O Ring (M20x1.5)	3
48	44842	NY	Plug, Drain	1	185	49763	BB	Head, Manifold w/Integral Unloader Body	1
49	14179	NBR	O Ring, Drain Plug 70D	1	188	549357	STCP R	Screw, HSH (M6x60)	6
53	49801	AL	Crankcase	1	249	30520		Assy, Adapter Mount	1
64	46229	STL	Pin, Crosshead	3	255	30516	STZP R	Assy, Bolt Mount	1
65	542402	BB	Rod, Plunger	3	283	990394		Kit, Oil Drain (Not Shown)	1
70	47215	NBR	Seal, Oil 70D	3	300	76975	NBR	Kit, Seal (Incls: 98,106,121,125)	1
90	547091	CC	Plunger (M14x25.5)	3	310	76976	NBR	Kit, Valve (Incls: 160,161,162,163,164,166,167,168,169,172)	1
98	46730	NBR	Washer, Seal 90D	3	400			Unloader, Integral (See Individual Parts)	1
99	542405	S	Retainer, Plunger (M6x35)	3	469	7332	BB	Injector, Chemical Fixed	1
100	46233	D	Retainer, Seal	3					

Bold Part Numbers are unique to a particular pump model. Italics are optional items. [] Date of latest production change. R Components comply with RoHS Directive.

View Tech Bulletins 002, 024, 036, 043, 055, 074 and 083 for additional information.

MATERIAL CODES (Not Part of Part Number): AL=Aluminum BB=Brass BP=Special Poly Blend CC=Ceramic CM Chrome moly D=Acetal LDPE=Low Density Polyethylene NBR=Medium Nitrile (Buna N) NY=Nylon PVDF=Polyvinylidene Fluoride RTP=Reinforced Composite

S=304SS STL=Steel STCP=Steel/Chrome Plated STZP=Steel/Zinc Plated TNM=Special High Strength

NOTE: Discard Key which may come standard with most motors and **use only the key included in this kit.**

Center raised pilot guide on the **Adapter Plate** assures proper alignment of pump and engine. Before mounting pump onto engine inspect engine for **recessed seal and bearing guide** to permit adapter to completely seat into recess and four bosses to be flush with engine face.

INTEGRAL UNLOADER

SPECIFICATIONS

	U.S. Measure	Metric Measure
Flow	3.0 gpm	(11.4 lpm)
PSI Range.....	100 3300 psi	(7 228 bar)
Inlet Port	3/8" NPTF	(3/8" NPTF)
Discharge Port w/Chemical Injector	3/8" NPTM	(3/8" NPTM)

UNLOADER TYPE

An integral unloader with built-in by-pass is part of the discharge manifold to provide system pressure regulation and pump protection. This pump also includes a fixed chemical injector for chemical application.

OPERATION:

Pump should be purged of air before commencing operation. Liquid must flow through the pump without discharge restriction to assure full system pressure is reached.

Install a pressure gauge close to the manifold head of the pump to assist in setting system pressure and to periodically monitor system pressure.

Setting and adjusting the regulator pressure must be done with the system turned on. Start the system with the unloader backed off to the lowest pressure setting (counterclockwise direction). Squeeze the trigger and read the pressure on the gauge at the pump. Do not read pressure at the gun or nozzle. If more pressure is desired, turn adjusting cap one quarter turn in a clockwise direction. Squeeze the trigger and read the pressure. Repeat this process until the desired system pressure is reached. Thread locking nut up to adjusting cap.

NOTE: Pressure is not set at the factory.

SERVICE:

The unloader should be serviced on the same schedule as the seals in the pump. Refer to the Service Manual for start-up, servicing of seals and valves, torque requirements and diagnosis and maintenance chart.

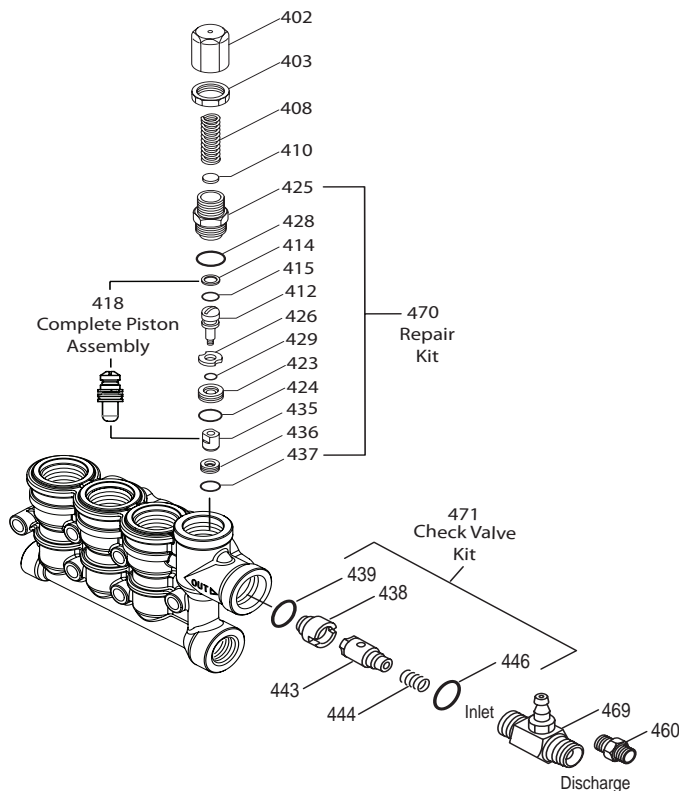

PARTS LIST

ITEM	PN	MATL	DESCRIPTION	QTY
402	547798	BB	Cap, Adjusting	1
403	45070	BB	Nut, Lock (M18 x 1)	1
408	32094	STZP R	Spring, Pressure	1
410	549352	STCP R	Retainer, Spring	1
412	45694	S	Stem, Piston	1
414	20184	PTFE	Back up Ring, Piston Stem	1
415	14190	NBR	O Ring, Piston Stem 70D	1
418		BB	Assy, Piston Included In Repair Kit	1
423	46249	BB	Retainer, Valve	1
424	13966	NBR	O Ring, Valve Retainer (Outer) 70D	1
425	547799	BB	Retainer, Piston	1
426	46250	S	Washer	1
428	26133	NBR	O Ring, Piston Retainer 80D	1
429	17399	NBR	O Ring, Valve Retainer (Inner) 80D	1
435	547800	S	Valve	1
436	49664	S	Seat	1
437	13963	NBR	O Ring, Seat 70D	1
438	46254	NY	Seat, Check Valve	1
439	13963	NBR	O Ring, Check Valve Seat 70D	1
443	49765	D	Valve, Check	1
444	45924	S	Spring	1
446	26133	NBR	O Ring, Body 80D	1
460	107681	BB	Fitting, Discharge (3/8" NPTM)	1
468	31767	NBR	Kit, O Ring (Incls:414,415,424,428,429,437,439,446)	1
469	7332	BB	Injector, Chemical Fixed	1
470	76179	NBR	Kit, Repair (Incls:412,414,415,423,424,425,426,428,429,435,436,437)	1
471	76146	NBR	Kit, Check Valve (Incls:438,439,443,444,446)	1

Italics are optional items. R Components comply with RoHS Directive.

MATERIAL CODES (Not Part of Part Number):

BB=Brass D=Acetal NBR=Medium Nitrile (Buna N) NY=Nylon
PTFE=Pure Polytetrafluoroethylene S=304SS STCP=Steel/Chrome Plated
STZP=Steel/Zinc Plated

7332 FIXED CHEMICAL INJECTOR

SPECIFICATIONS

	U.S. Measure	Metric Measure
Flow	3.0 gpm	(11.4 lpm)
Nozzle Orifice.....	2.1 mm	(2.1 mm)
Hose Barb	1/4"	(1/4")
Inlet Port	M18 x 1.0	(M18 x 1.0)
Discharge Port	3/8" NPTM	(3/8" NPTM)
Weight	5.3 oz.	(0.15kg)
Dimensions	2 x 1 x 1.75"	(52 x 25 x 45 mm)

CHEMICAL INJECTOR PERFORMANCE CHART

Orifice Size	Maximum Injecting Pressure	Maximum Chemical Draw	Pressure Drop Across Injector At System Pressure (2850 psi)
2.1 mm	250 psi	37.2 oz/min	141 psi

Optimum performance of chemical injector occurs with 35 ft. high pressure hose and a minimum 3/8" I.D. The type of hose, extended lengths, reduced I.D. and fittings may create back pressure in excess of the low pressure nozzle rating and prevent the injector from drawing chemical. See hose friction loss Chart in Service Manual. **Deduct hose friction loss from above low psi nozzle. Contact Cat Pumps for assistance with other options.**

CAUTION: Deduct the pressure drop shown in the performance chart from your desired system pressure to arrive at the maximum high pressure nozzle rating. This is essential to avoid over-pressurizing the pump.

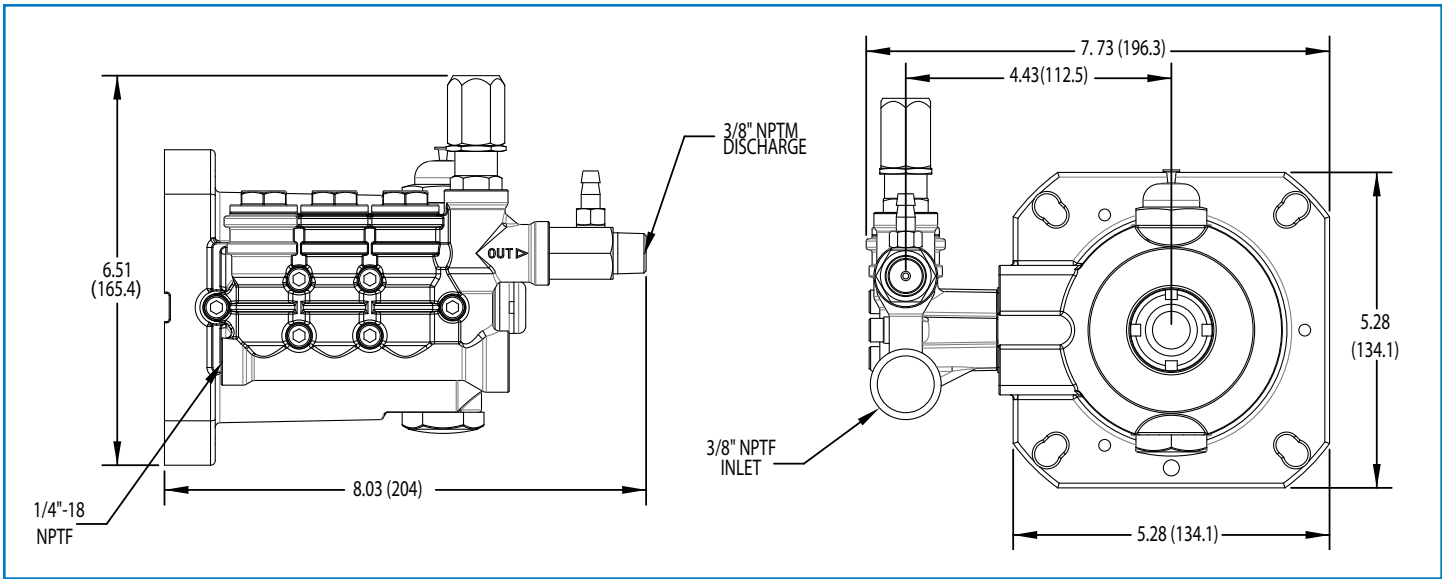

Models 4PPX25GSI, 4PPX30GSI



CAT PUMPS
 1681 - 94TH LANE N.E. MINNEAPOLIS, MN 55449-4324
 PHONE (763) 780-5440 — FAX (763) 780-2958
 e-mail: techsupport@catpumps.com
 www.catpumps.com