

XR PROFESSIONAL 5.50 GROSS TORQUE*

127 CC

Bore 2.44 in. (62.00 mm)

Stroke 1.65 in. (42.10 mm)

Oil Capacity 18-20 fl. oz. (0.53-0.59 L)

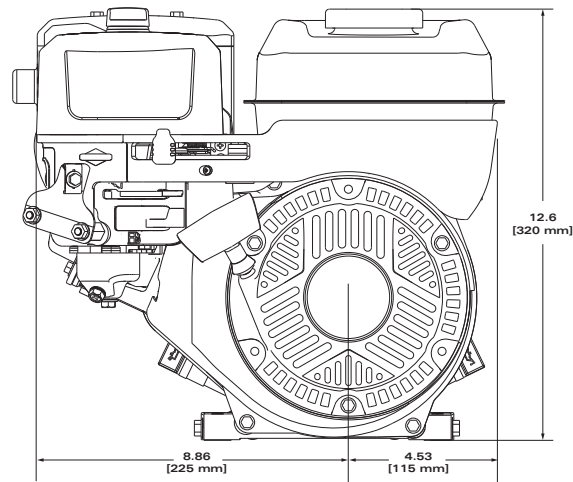
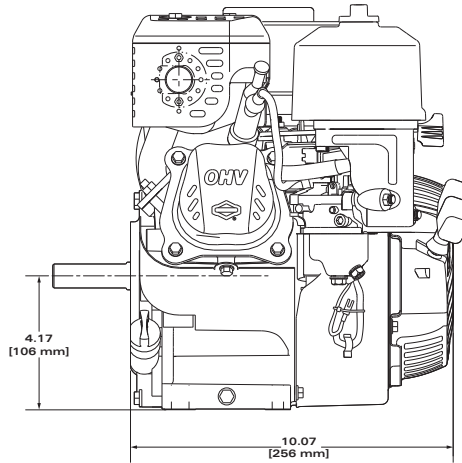

FEATURES:

Dura-Bore™ cast iron cylinder sleeve for extended life

Float carburetor for consistent easy starting

Maxi-Clean™ automotive-type pleated paper air filter provides superior protection for long engine life

Overhead valve design (OHV) for cooler operation and longer valve life

Fuel Shut Off

Mechanical Governor

Buyer protection package provides two-year limited consumer engine warranty**

MTT	Crankshaft #	P.T.O. Diameter	Drilled & Tapped	Keyway	Length	Starter Position	Controls	Manual Choke	Flange Mtg.	Accessory Mtg. Boss	Ground Wire Terminal	Rocker Stop Switch	Key Stop Switch	Oil Guard	Fuel Tank (Quarts)	Top Governor Speed	Notes
83132																	
1035-F1	797529	3/4 in.	5/16-24	3/16-Str.	2-27/64	12:00	R/AG/MF	X	X		X	X			2.1	3600	11
1036-F1	797695	5/8 in.	Threaded 5/8-18		2-27/64	12:00	R/AG/MF	X	X		X	X			2.1	4000	11
1038-F1	797690	25/32 Taper	5/16-24	----	2-13/16	12:00	FC	X	X			X			2.1	3750	11
1040-F1	797709	5/8 in.	1/4-28	3/16-Str.	2-27/64	12:00	R/AG/MF	X	X		X	X			2.1	3300	
83152																	
1049-F1	797689	3/4 in.	6:1 CCW	3/16-Str.	1-13/16	12:00	R/AG/MF	X			X	X			2.1	3600	11

*All power levels are stated gross torque at 2600 RPM per SAE J1940 as rated by Briggs & Stratton.

(11) PTO Ball Bearing

Engines in bold type have promotional pricing