





# FORCE PUSH BLOWER Owner's Manual



Patent #6,253,416 and other patents pending  
**FORCE BLOWER Owner's Manual**  
F902H, F1002V, F1302H, F1402V, F1802V  
Beginning Serial #: 110215001

## Accessories

HOLD DOWN KIT	SOLID FRONT TIRE	PARKING BRAKE	CASTER KIT
<p>To secure blower for transportation on trailer floors.</p> 	<p>Solid flat-free front tire.</p> 	<p>Effective and Easy to use to prevent blower from rolling.</p> 	<p>For greater maneuverability on hard surfaces.</p> 
P/N 440120	P/N 440279	P/N 440140	P/N 440293

Original Instructions

IMPORTANT- READ CAREFULLY BEFORE USE AND KEEP FOR FUTURE REFERENCE



## FORCE PUSH BLOWER Owner's Manual

---

### CONTENTS

SPECIFICATIONS, SAFETY, AND INSTRUCTION LABELS	3
ENGINE LABELS AND PACKING CHECKLIST	4
ASSEMBLY	5
OPERATION	6
MAINTENANCE AND TROUBLESHOOTING	7
MAINTENANCE RECORD	8
ILLUSTRATED PARTS AND PARTS LISTS	9-11

NOT FOR REPRODUCTION



# FORCE PUSH BLOWER Owner's Manual

## SPECIFICATIONS

	F1002V	F902H	F1302H	F1402V	F1802V
Engine HP	10.0 HP (6.6kW)	9.0 HP (6.6kW)	13.0 HP (9.6kW)	14.0 HP (10.4kW)	18 HP (13.42kW)
Engine Model	19L2320055F1	GX270UTQA2	GX390UTQA2	25V3320005F1	3564420298F1
Engine Type	B & S VANGUARD	HONDA OHV	HONDA OHV	B & S VANGUARD	B & S VANGUARD
Engine Fuel Capacity	3.96 qt. (3.75L)	6.3 qt. (6.0L)	6.5 qt. (6.1L)	6.5 qt. (6.1L)	9 qt. (8.52L)
Engine Oil Capacity	0.88 qt. (0.83L)	1.16 qt. (1.1L)	1.16 qt. (1.1L)	1.0 qt. (0.95L)	1.75 qt. (1.66L)
Total Unit Weight:	143 # (64.8Kg)	143 # (64.8Kg)	160 # (72.6Kg)	157 # (71.2Kg)	179 # (81.2Kg)
Overall Length:	58"(1.43m)	58"(1.43m)	58"(1.43m)	58"(1.43m)	58"(1.43m)
Overall Width	29.25" (0.74m)	29.25" (0.74m)	29.25" (0.74m)	29.25" (0.74m)	29.25" (0.74m)
Overall Height	45" (1.14m)	45" (1.14m)	45" (1.14m)	45" (1.14m)	45" (1.14m)
Max Operating Angle	20°	20°	20°	20°	25°

## SAFETY



**WARNING**



This product can expose you to chemicals including gasoline engine exhaust, which is known to the State of California to cause cancer, and carbon monoxide, which is known to the State of California to cause birth defects or other reproductive harm. For more information go to [www.P65Warnings.ca.gov](http://www.P65Warnings.ca.gov).

## INSTRUCTION LABELS

The labels shown below were installed on your BILLY GOAT® FORCE Blower. If any labels are damaged or missing, replace them before operating this equipment. For your convenience in ordering replacement labels, part numbers are included in the Illustrated Parts List. The correct position for each label may be determined by referring to the Figure and Item numbers shown.



LABEL SPARK ARRESTOR  
P/N 100252



LABEL READ OWNERS MANUAL  
ITEM #44 P/N 890301

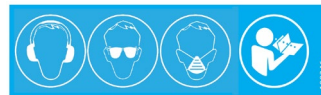

LABEL SAFETY PROTECT  
ITEM# 45 P/N 100346



DANGER FLYING DEBRIS  
ITEM # 46 P/N 810736



LABEL EXPLOSIVE FUEL  
ITEM # 43 P/N 100261



LABEL THROTTLE CONTROL  
ITEM # 42 P/N 810656



# FORCE PUSH BLOWER Owner's Manual

## ENGINE LABELS

### HONDA

■ READ OWNER'S MANUAL BEFORE OPERATION.  
 ■ LIRE LE MANUEL D'UTILISATEUR AVANT USAGE.  
 ■ VOR INBETRIEBNAHME UNBEDINGHT BEDIENUNGSANLEITUNG DURCHLESEN.  
 ■ NO UTILIZAR SINANTES NO HABER LEIDO EL MANUAL.  
HONDA MOTOR CO., LTD. MADE IN JAPAN



**OIL ALERT**  
 ■ WHEN OIL LEVEL LOW,  
 ENGINE STOPS IMMEDIATELY.

### BRIGGS AND STRATTON VANGUARD

**ENGINE MAINTENANCE**  
 1. CHECK OIL LEVEL 6 HOURS  
 2. CHECK & CLEAN AIR CLEANER 25 HOURS  
 3. CHANGE OIL 50 HOURS  
 4. REPLACE OIL FILTER 100 HOURS  
 5. CLEAN COOLING FINS 100 HOURS  
See Operating and Maintenance Instructions

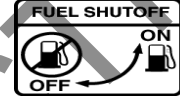

## PACKING CHECKLIST

These items should be included in your carton. If any of these parts are missing, contact your dealer. Your BILLY GOAT® FORCE Blower was shipped in one carton, completely assembled except for the Upper Handle Assembly and Front Diverter. Mounting hardware for the Upper Handle Assembly can be found in the parts bag.



**READ** all safety instructions before assembling unit.

**TAKE CAUTION** when removing the unit from the box the Handle Assembly is attached to the unit by cables.



**PUT OIL IN ENGINE BEFORE STARTING**

### PARTS BAG & LITERATURE ASSY

Warranty card P/N- 400972, Owner's Manual P/N-440313, General Safety and Warnings Manual P/N-100294, Declaration of Conformity P/N-440022, Handle Hardware-Items #10, #11, #74, #71 and #36



### Boxing Parts Checklist

- Front Air Diverter  
(For F902S, F902H, F1302H,  
F1402S models only)  
Item#38  
F9 MODEL P/N-440045-4  
F13/F14 MODEL P/N-440045-5
- Handle Upper Assembly  
Item #30 P/N-440030
- Parts Bag & Literature Assy  
P/N-440266
- Honda 9 or 13HP
- B & S Vanguard 10, 14 or  
18HP



# FORCE PUSH BLOWER Owner's Manual

## ASSEMBLY

1. The hardware for attaching the upper handle to the lower is in the parts bag. Install upper handle (item 30), to preassembled lower handle (item 28) by sliding the upper handle over and down the outside of the lower handle. Using the bolts (items #36 and #71), washers (item #10) and lock nut (item #11) to install upper handle to lower handle. *NOTE:* The Pigtail bolt should go on the side that the pull start is on and the open end should be facing down. Finish installing the other side of the upper handle assembly using screw and lock nut provided. (See Fig. 1)
2. The throttle control will be attached to the throttle arm on the engine and wrapped around the engine for shipping. Unwrap and secure throttle control (item #31) to upper handle with screws (item #17). Screws will already be mounted in handle. Simply remove and use to mount the throttle control securing the cable with two Ty-wraps. The Aim-and-Shoot™ is not attached, you will need to unroll the cable and attach the ball end to the lever and seat the cable end into the hole on the saddle clamp, with the cable running through the slot. To keep the cable from being damaged use three ty-wraps (item 74) to secure it to the handle as shown making sure that the cable is not rubbing against the tire. Note: the cable should be seated properly in the saddle and should follow the contours of the handle. (See Fig. 2)
3. Connect spark plug wire.

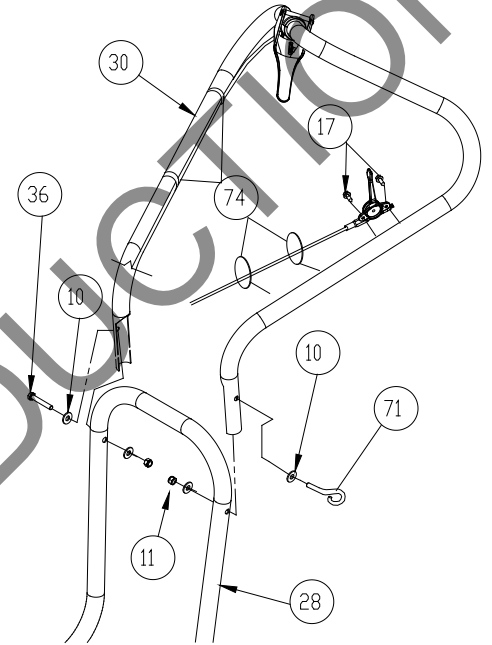

Fig. 1

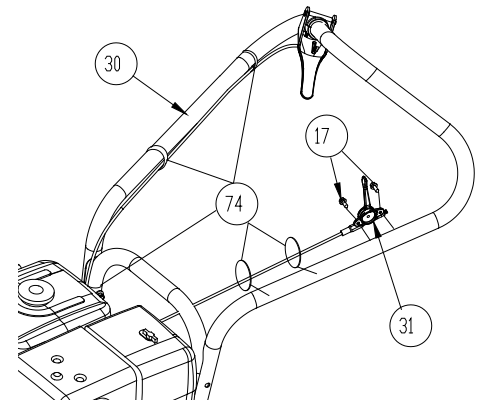

Fig. 2



Good routing



Bad routing



## FORCE PUSH BLOWER Owner's Manual

### OPERATION

#### BLOWING OPERATION

Your Billy Goat Force blower is equipped with an air director cone and the patented Aim-N-Shoot™ control lever to allow the operator to direct the air stream up or down as required to assist in moving debris. This feature is extremely useful when debris has piled up to the point that it cannot be blown any farther. The air stream can be directed upward to blow the top of the debris pile over and allow the operator to continue moving more debris farther.

#### ADJUSTING AIR DIRECTOR

To adjust air direction, squeeze the Aim-N-Shoot control lever. When you want to blow debris at the same angle for an extended period, choose a suitable position and use the finger controlled push button lock to lock the cone in position. For operations that do not require the use of the Aim-N-Shoot feature the manual adjustment knob (see Fig. 3) can be used to permanently lock the cone into position. **NOTE:** be sure to release the knob when returning to using the Aim-N-Shoot.

**⚠ DO NOT** position director cone to where it will blow debris towards people, vehicles or other objects in vicinity. Flying debris may damage, harm, or cause injury to people or objects in air flow range.

#### FRONT DIVERTER POSITIONING (F9 and F13 models only)

The removable front diverter adapter can be slipped inside the cone to direct the air stream forward. First turn off engine, and then simply collapse the fold in the larger opening of the diverter and slide inside the cone and allow it to expand. Then position to the desired angle by rotating the diverter. This option is extremely useful for cleaning out long cracks in pavement or for cleaning under bushes, building overhangs or along curbs. (See Fig. 3 and 4)

**⚠ WARNING:** The unit will be more difficult to control due to the air exiting the unit. Keep hands on the unit at all times when using the front diverter. Please note that the Aim-N-Shoot feature will not function when the front diverter is installed.

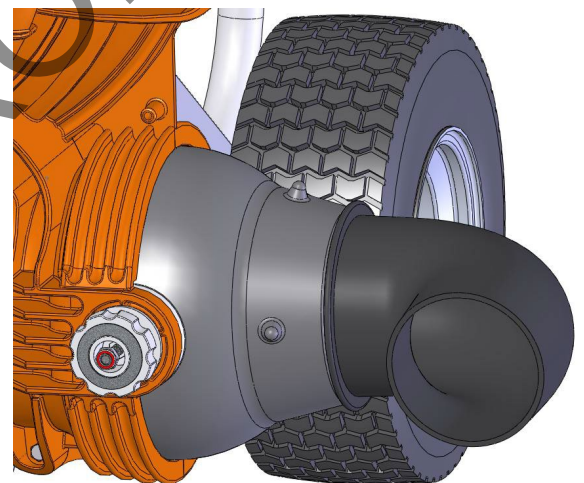
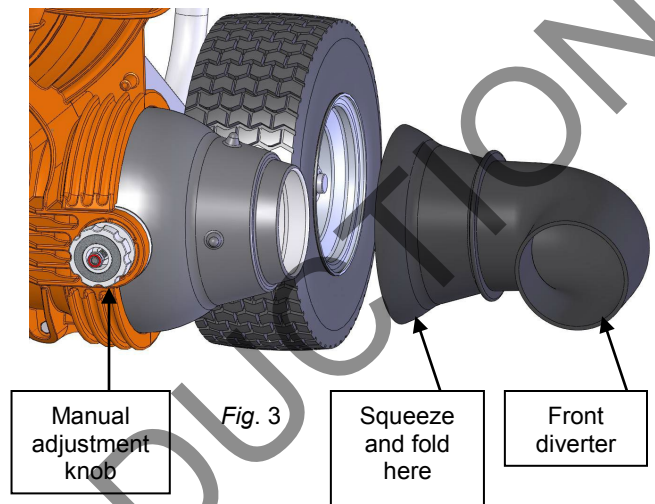



# FORCE PUSH BLOWER Owner's Manual

## MAINTENANCE

### PERIODIC MAINTENANCE

Periodic maintenance should be performed at the following intervals:

Maintenance Operation	Every Use	Daily or Every 5 Hours	Every 100-150 Hours
Inspect for worn or damaged parts	•		
Check for excessive vibration		•	
Inspect impeller for cracks or damage			•
Inspect for loose parts		•	

### IMPELLER REMOVAL

1. Wait for engine to cool and disconnect spark plug.
2. Remove housing front cover, by removing eleven bolts and nuts (items #13 & #14), around outside of front cover.
3. Remove impeller bolt (item #35), lock washer (item #86) and washer (item #34).
4. DO NOT pry on impeller. Pull on center hub area only of impeller. Using a penetrating oil can help loosen a stuck impeller.
5. Reinstall new impeller in reverse order of removal.
6. Tighten impeller bolt. Torque impeller bolt (see Parts List on page 10 for proper impeller bolt torque specifications).

### TIRE AIR PRESSURE

Check at regular intervals and maintain.

Front Tires - 24 Psi (165 kPa).

Rear Tires - 20 Psi (137 kPa).

## TROUBLESHOOTING

Problem	Possible Cause	Solution
Abnormal vibration	Loose or out of balance impeller. Debris in impeller.  Loose engine.	Check impeller and replace if required. Clear debris with compressed air or a backpack blower (see below pictures).* Check engine.
Engine will not start	Engine not in full choke position. Out of gasoline or bad, old gasoline. Spark Plug wire disconnected. Gas valve off. Dirty air cleaner.	Check choke position. Check gasoline. Connect spark plug wire. Turn on gas valve. Clean or replace air cleaner. Contact a qualified service person.
Engine is locked, will not pull over	Engine problem.	Contact an engine servicing dealer for engine problems.
Aim-N-Shoot™ lever sticking	Debris stuck around cone. Cone adjustment knob too tight. Adaptor mount nut (item 38) too tight.	Clean debris. Apply silicone based lubricant to pivot points.  Loosen manual adjustment knob. Loosen nut.

\*Using compressed air, or a backpack blower, you can loosen or free debris easily from the impeller and housing, which can cause wear and tear on the machine. You can manually remove debris by taking off the front housing. (See Fig. 5 and 6) **NOTE:** Always disconnect the sparkplug when servicing.

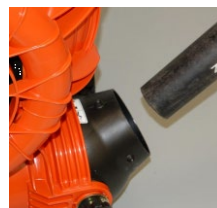

Fig. 5



Fig. 6







# FORCE PUSH BLOWER Owner's Manual

## FORCE PUSH PARTS DRAWING

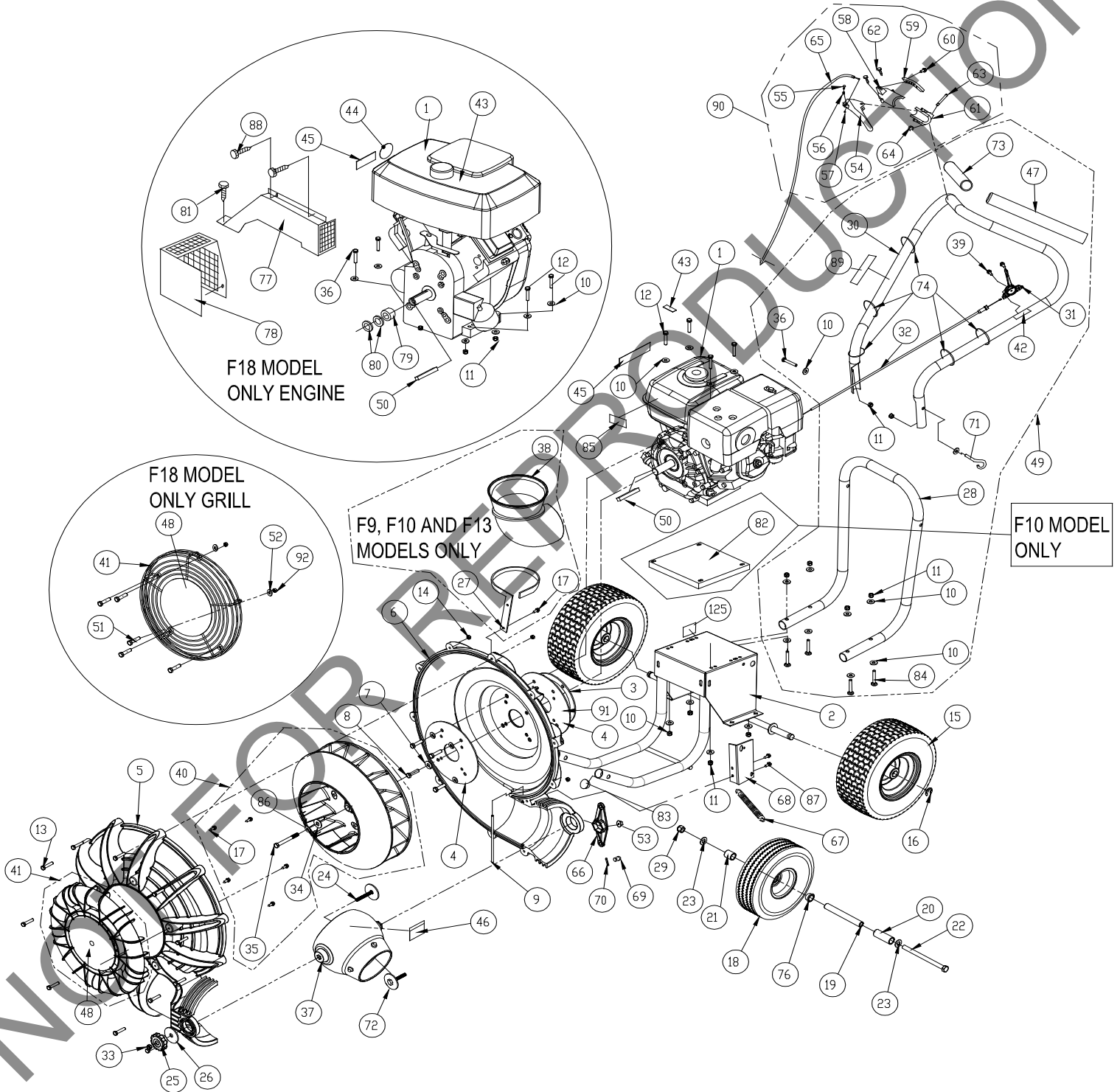



# FORCE PUSH BLOWER Owner's Manual

## FORCE PUSH PARTS LIST

ITEM NO.	DESCRIPTION	F1302H		F1402V		F902H		F1002V		F1802V	
		PART NUMBER	QTY.	PART NUMBER	QTY.	PART NUMBER	QTY.	PART NUMBER	QTY.	PART NUMBER	QTY.
1	ENGINE 13 HP HONDA GX390UT2 QA2	430366	1	-	-	-	-	-	-	-	-
	ENGINE, VANGUARD 400	-	-	440346	-	-	-	-	-	-	-
	ENGINE 9 HP HONDA GX270	-	-	-	-	430287	1	-	-	-	-
	ENGINE 10HP VANGUARD	-	-	-	-	-	-	440342	1	-	-
	ENGINE 18 VANGUARD	-	-	-	-	-	-	-	-	812240	1
2	BASE ENGINE WA	440320-S	1	440320-S	1	440320-S	1	440320-S	1	440320-S	1
3	SPACER RING ENGINE	440009	1	440009	1	440009	1	440009	1	440009	1
4	PLATE, HOUSING REINFORCEMENT	440330	2	440330	2	440330	2	440330	2	440330	1
5	HOUSING FRONT MOLDED	440023	1	440023	1	440023	1	440023	1	440023	1
6	HOUSING BACK MOLDED	440024	1	440024	1	440024	1	440024	1	440024	1
7	WASHER LOCK	8177012	5	8177012	5	8177012	4	8177012	4	8177012	4
8	SCREW CAP 3/8-16X1 1/2 ZP	8041052	4	8041052	4	8041052	4	8041052	4	-	-
	SCREW CAP 3/8-16X2" ZP	-	-	-	-	-	-	-	-	8041054	4
9	ROD HAND STOP	440057	1	440057	1	440057	1	440057	1	440057	1
10	WASHER 5/16 FLATWASHER Z/P	8171003	14	8171003	14	8171003	14	8171003	14	8171003	14
11	NYLON INSERT LOCKNUT 5/16-18	8160002	10	8160002	10	8160002	10	8160002	10	8160002	10
12	SCREWCAP 5/16-18 X 1.75 ZP	8041031	4	8041031	4	8041031	4	-	-	8041031	2
	SCREWCAP 5/16"-18 X2 3/4" GR 5 HCS ZP	-	-	-	-	-	-	8041034	4	-	-
13	SCREWCAP 1/4-20 x 1 1/2	8041008	11	8041008	11	8041008	11	8041008	11	8041008	11
14	NUT FLANGE 1/4-20	900455	11	900455	11	900455	11	900455	11	900455	11
15	WHEEL & TIRE 13" X 5" PNEUMATIC	440054	2	440054	2	440054	2	440054	2	440054	2
16	RING RETAINING 3/4	850230	2	850230	2	850230	2	850230	2	850230	2
17	SCREW SELF-TAP 5/16 NC X 3/4 HEX	8122082	7	8122082	7	8122082	7	8122082	7	-	-
18	WHEEL ASSY 10" PNEUMATIC	400295	1	400295	1	400295	1	400295	1	400295	1
19	SPACER FRONT AXLE	440220	1	440220	1	440220	1	440220	1	440220	1
20	SPACER LH WHEEL FRONT	440224	1	440224	1	440224	1	440224	1	440224	1
21	SPACER RH WHEEL FRONT	440221	1	440221	1	440221	1	440221	1	440221	1
22	SCREWCAP 1/2-13 x 9 1/2"	8041240	1	8041240	1	8041240	1	8041240	1	8041240	1
23	WASHER FLAT 1/2" SAE	8172011	2	8172011	2	8172011	2	8172011	2	8172011	2
24	WASHER W/BOLT WA	440075	1	440075	1	440075	1	440075	1	440075	1
25	KNOB 3/8-16 SOLID HUB	811230	1	811230	1	811230	1	811230	1	811230	1
26	WASHER 2.25 OD x .515 ID x .134 ZP	610308-P	1	610308-P	1	610308-P	1	610308-P	1	610308-P	1
27	BRACKET HOLDER WA	440240	1	440240	1	440240	1	440240	1	-	-
28	HANDLE LOWER	440034	1	440034	1	440034	1	440034	1	440034	1
29	NYLON INSERT LOCKNUT 1/2-13	8160005	1	8160005	1	8160005	1	8160005	1	8160005	1
30	HANDLE UPPER	440035	1	440035	1	440035	1	440035	1	440035	1
31	CONTROL THROTTLE	440013	1	440013	1	440013	1	-	-	440013	1
32	CABLE THROTTLE CONTROL	440014	1	440014	1	440014	1	-	-	440178	1
33	NUT LOCK 3/8-16 LT WT THIN ZP	8161042	1	8161042	1	8161042	1	8161042	1	8161042	1
34	WASHER 1.5 O.D.X 0.45 I.D. X 0.5	440176	1	440176	1	440176	1	440176	1	440176	1
35	SCREWCAP 3/8-24 X 2 3/4" GR. 8 (38 +/-2 ft-lbs.)	790167	1	-	-	-	-	-	-	-	-
	SCREWCAP 7/16-20 X 2 3/4" GR.8 (60 +/-2 ft-lbs.)	-	-	440285	1	440285	1	440285	1	-	-
	SCREWCAP 3/8-24 X 4 GR.8 (38 +/-2 ft-lbs.)	-	-	-	-	-	-	-	-	8042062	1
36	SCREWCAP 5/16"-18 X 2" ZP	8041032	1	8041032	1	8041032	1	8041032	1	8041032	3
37	DIRECTOR CONE 5"	440044-S	1	440044-S	1	-	-	-	-	-	-
	DIRECTOR CONE 4"	-	-	-	-	440046-S	1	440046-S	1	-	-
	DIRECTOR CONE 6"	-	-	-	-	-	-	-	-	440170-S	1
38	DIVERTOR FRONT	440045-5	1	440045-5	1	440045-4	1	440045-4	1	-	-
39	SCREW SM #10-24X1/2" DRILL POINT	8122064	2	8122064	2	8122064	2	8122064	2	8122064	2
40	IMPELLER ASSEMBLY 17"	440236	1	440236	1	440236	1	440236	1	-	-
	IMPELLER SERVICE ASSY FORCE 18HP	-	-	-	-	-	-	-	-	440162	1
41	GRILL FRONT BLOWER	440067-1-S	1	440067-1-S	1	440067-1-S	1	440067-1-S	1	440171-S	1
42	LABEL THROTTLE CONTROL	810656	1	810656	1	810656	1	810656	1	810656	1
43	LABEL FUEL EN/SP	-	-	-	-	-	-	100261	1	100261	1
45	LABEL SAFETY PROTECT READ MANUAL	100346	1	100346	1	100346	1	100346	1	100346	1
46	LABEL DANGER FLYING DEBRIS	810736	1	810736	1	810736	1	810736	1	810736	1
47	GRIP 1-1/4" ID x 13"	440012	1	440012	1	440012	1	440012	1	440012	1
48	LABEL FORCE	440268	1	440268	1	440268	1	440268	1	440268	1
49	HANDLE ASSY UPPER	440104	1	440104	1	440104	1	440104	1	440104	1
50	KEY 1/4" SQ X 2.25"	9201123	1	-	-	9201123	1	9201123	1	-	-
	KEY 1/4" SQ X 3 3/4	-	-	9201130	1	-	-	-	-	9201130	1
51	SCREWCAP 1/4-20 X 1"	-	-	-	-	-	-	-	-	8041006	5
52	WASHER FLAT 1/4	-	-	-	-	-	-	-	-	8171002	5
53	NUT LOCK 1/4-20 2 WAY	8142004	1	8142004	1	8142004	1	8142004	1	8142004	1
54	HANDLE DIVERTER FORCE	440119	1	440119	1	440119	1	440119	1	440119	1
55	PIN LATCH DIVERTER	440118	1	440118	1	440118	1	440118	1	440118	1
56	SPRING COMPRESSION 0.281 X 0.88	440129	1	440129	1	440129	1	440129	1	440129	1
57	RING RETAINING .122 DIA	440125	1	440125	1	440125	1	440125	1	440125	1
58	SADDLE LOWER DIVERTER	440115	1	440115	1	440115	1	440115	1	440115	1
59	PLATE LOCK DIVERTER	440116	1	440116	1	440116	1	440116	1	440116	1
60	SCREW PLASTITE #6-19 X 5/8"	440126	1	440126	1	440126	1	440126	1	440126	1



# FORCE PUSH BLOWER Owner's Manual

ITEM NO.	DESCRIPTION	F1302H		F1402V		F901H		F1002V		F1801V	
		PART NUMBER	QTY.	PART NUMBER	QTY.	PART NUMBER	QTY.	PART NUMBER	QTY.	PART NUMBER	QTY.
61	SADDLE UPPER DIVERTER	440114	1	440114	1	440114	1	440114	1	440114	1
62	SCREW PLASTITE #10-14 X 1"	440132	2	440132	2	440132	2	440132	2	440132	2
63	PIN PIVOT DIVERTER CONTROL	440123	1	440123	1	440123	1	440123	1	440123	1
64	RING RETAINING 5/16	430327	1	430327	1	430327	1	430327	1	430327	1
65	CABLE ASSY	440117	1	440117	1	440117	1	440117	1	440117	1
66	DIVERTER PIVOT ADAPTOR	440121	1	440121	1	440121	1	440121	1	440121	1
67	SPRING EXTENSION 0.468 X 5.25	440130	1	440130	1	440130	1	440130	1	440130	1
68	BRACKET DIVERTER FORCE	440212	1	440212	1	440212	1	440212	1	440212	1
69	PIN CLEVIS 1/4 X 3/4	440124	1	440124	1	440124	1	440124	1	440124	1
70	.051 X 3/4" HITCH PIN CLIP	440193	1	440193	1	440193	1	440193	1	440193	1
71	EYEBOLT PIGTAIL 5/16"-18 X 1 1/4"	440280	1	440280	1	440280	1	440280	1	440280	1
72	ADAPTOR MOUNT WA	440122	1	440122	1	440122	1	440122	1	440122	1
73	GRIP 1-1/4" ID x 9.5" LONG	440146	1	440146	1	440146	1	440146	1	440146	1
74	TY-WRAP	900407	5	900407	5	900407	5	900407	5	900407	5
76	FORCE WHEEL BEARING .751 ID	440055	2	440055	2	440055	2	440055	2	440055	2
77	GUARD MANIFOLD	-	-	-	-	-	-	-	-	812243	1
78	GUARD MUFFLER SW	-	-	-	-	-	-	-	-	812410	1
79	SPACER 1" ID X 2" OD X 0.890 TK	-	-	-	-	-	-	-	-	830112	1
80	SPACER 1" ID X 2" OD X 0.265 TK	-	-	-	-	-	-	-	-	830113	2
81	SCREW SELF TAP 1/4"-20 X 5/8"	-	-	-	-	-	-	-	-	890359	2
82	SPACER PLATE WELDMENT	-	-	-	-	-	-	440148	1	-	-
83	PLUG	791056	2	791056	2	791056	2	791056	2	791056	2
84	CARRIAGE BOLT 3/8"-16 X 2" ZP	8024062	4	8024062	4	8024062	4	8024062	4	8024062	4
85	SPARK ARRESTOR LABEL	100252	1	100252	1	100252	1	100252	1	100252	1
86	WASHER LOCK 3/8 ST MED	8177012	1	8177012	1	-	-	-	-	8177012	1
	WASHER LOCK 7/16 ST MED	-	-	-	-	8177013	-	8177013	1	-	-
87	SCREW PLASTITE 1/4"-10 X 3/4" HWH ZP	840082	2	840082	2	840082	2	840082	2	840082	2
88	BOLT 1/4"-20 X 1/2" SER FLANGE	-	-	-	-	-	-	-	-	812381	2
89	LABEL AIM AND SHOOT	440332	1	440332	1	440332	1	440332	1	440332	1
90	DIVERTER ASSY	440312	1	440312	1	440312	1	440312	1	440312	1
91	PLATE ENGINE SPACER WA F1800	-	-	-	-	-	-	-	-	440174	1
92	NUT LOCK 1/4-20 HEX ZP	-	-	-	-	-	-	-	-	8160001	5

NOT FOR REPRODUCTION