

Code	
<b>2200791684</b>	<b>02</b>
Edit. 11/2014	

## INSTRUCTION AND MAINTENANCE MANUAL

# DRYERS

## C15 – C100

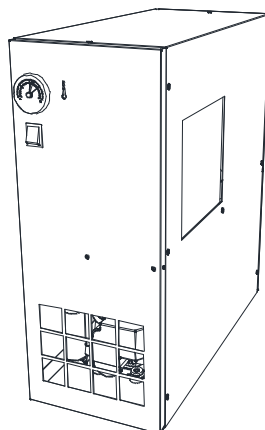

READ THIS MANUAL CAREFULLY BEFORE CARRYING OUT ANY OPERATIONS ON THE DRYER.

### CONTENTS

#### PART A: INFORMATION FOR THE USER

- 1.0 GENERAL CHARACTERISTICS
- 2.0 INTENDED USE
- 3.0 OPERATION
- 4.0 GENERAL SAFETY STANDARDS
- 5.0 DESCRIPTION OF DANGER SIGNALS
- 6.0 DANGER ZONES
- 7.0 SAFETY DEVICES

- 8.0 POSITION OF PLATES
- 9.0 DRYERS ROOM
- 10.0 TRANSPORT AND HANDLING

- 11.0 UNPACKING
  - 12.0 INSTALLATION
  - 13.0 DIMENSIONS AND TECHNICAL DATA
  - 14.0 MACHINE ILLUSTRATION
  - 15.0 PARTIAL ROUTINE MAINTENANCE
  - 16.0 SCRAPPING THE DRYERS
  - 17.0 TROUBLE-SHOOTING AND EMERGENCY REMEDIES
- PART B: INFORMATION RESERVED FOR TECHNICALLY SKILLED PERSONNEL**
- 18.0 STARTING UP

**ATTENTION: THERE IS A COPY OF THE WIRING DIAGRAM INSIDE THE ELECTRIC PANEL**

#### ADDRESSES OF ASSISTANCE CENTRES

In the event of breakdown or malfunction of the dryer, switch it off and do not tamper with it. If repairs are needed, apply only to a technical assistance centre approved by the manufacturer and insist on the use of original spare parts. Failure to comply with the above may endanger the safety of the machine.

#### INTRODUCTION

Keep this manual with care for future consultation; the use and maintenance manual is an integral part on the dryer. Read this manual carefully before carrying out any operations on the dryer.

The installation of the dryer and all operations involving it must be performed in conformity with the regulations in force concerning electric plants and personal safety.

**CHARACTERISTICS AND SAFETY PRECAUTIONS**



**BEFORE REMOVING THE PROTECTIVE GUARDS TO CARRY OUT ANY MAINTENANCE ON THE MACHINE, SWITCH OFF THE ELECTRIC POWER SUPPLY AND DISCHARGE THE RESIDUAL PRESSURE INSIDE THE UNIT.  
ALL WORK ON THE ELECTRIC PLANT, HOWEVER SLIGHT, MUST BE CARRIED OUT BY PROFESSIONALLY SKILLED PERSONNEL.**

The manufacturer does not accept responsibility for damage caused as a result of negligence of failure to abide by the instructions given above.

**THIS MACHINE IS NOT SUITABLE FOR EXTERNAL INSTALLATION**

**THIS MACHINE CORRESPOND TO THE ESSENTIAL SAFETY REQUIREMENTS FORESEEN FROM THE EUROPEAN STANDARD (2006/42 CE).**

**THE LUBRICATING LIQUIDS AND OTHER EVENTUAL FLUIDS MUST NOT BE DISCHARGED IN THE ENVIRONMENT. THESE POLLUTING AND HAZARDOUS PRODUCTS MUST COMPULSORY BE DISPOSED BY CHARGING AUTHORISED AND SPECIALISED FIRMS ACCORDING TO THE DIFFERENT TYPOLOGY OF PRODUCT.**

**DIFFERENTIATE THE COMPRESSOR COMPONENTS ACCORDING TO THE DIFFERENT CONSTRUCTION MATERIALS (PLASTIC, COPPER, IRON, OIL FILTER, AIR FILTER ECC...)**

**1.0 GENERAL CHARACTERISTICS**

The dryer is a chilling machine with direct expansion and dry evaporator.

The air to be dried is sent to the heat exchanger in which the water vapour present is condensed: the condensate gathers in the separator and is discharged outside through a steam trap.

**2.0 INTENDED USE**

The dryer has been built to dry the compressed air for industrial use. The dryer cannot be used in premises where there is a risk of fire or explosion or where work is carried out which releases substances into the environment which are dangerous with regard to safety (for example: solvents, inflammable vapours, alcohol, etc.).

In particular the appliance cannot be used to produce air to be breathed by humans or used on direct contact with foodstuffs. These uses are allowed if the compressed air produced is filtered by means of a suitable filtering system (Consult the manufacturer for these special uses.)

This appliance must be used only for the purpose for which it was specifically designed. All other uses are to be considered incorrect and therefore unreasonable. The Manufacturer cannot be held responsible for any damage resulting from improper, incorrect or unreasonable use.

**3.0 OPERATION**

The gaseous refrigerant coming from the evaporator (4) is sucked by the refrigeration compressor (1) and it is pumped into the condenser (2). This one allows its condensation, eventually with the help of the fan (3); the condensed refrigerant passes through the dewatering filter (8) and it expands through the capillary tube (7) and goes back to the evaporator where it produces the refrigerating effect. Due to the heat exchange with the compressed air which passes through the evaporator against the stream, the refrigerant evaporates and goes back to the compressor for a new cycle.

The circuit is equipped with a bypass system for the refrigerant; this intervenes to adjust the available refrigerating capacity to the actual cooling load. This is achieved by injecting hot gas under the control of the valve (9): this valve keeps constant the pressure of the refrigerant in the evaporator and therefore also the dew point never decreases below 0 °C (32 °F) in order to prevent the condensate from freezing inside the evaporator. The dryer runs completely automatically.

**DRYER FLOW DIAGRAM**

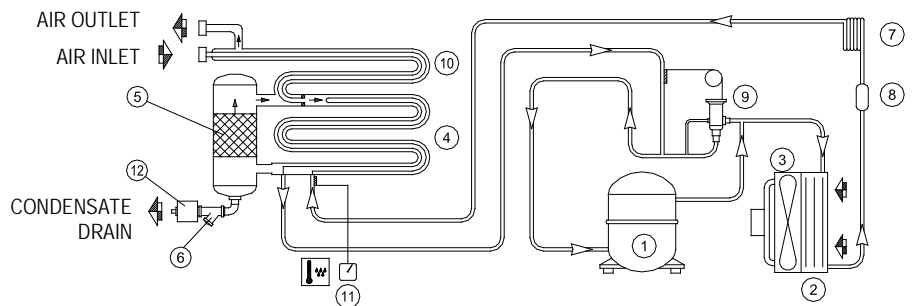

1) REFRIGERANT COMPRESSOR	7) EXPANSION CAPILLARY TUBE
2) CONDENSER	8) REFRIGERANT FILTER
3) MOTOR FAN	9) HOT GAS BYPASS VALVE
4) EVAPORATOR	10) AIR-TO-AIR EXCANGER
5) DEMISTER CONDENSATE SEPARATOR	11) DEW POINT THERMOMETER
6) IMPURITY TRAP	12) CONDENSATE DRAIN

4.0 GENERAL SAFETY STANDARD

The appliance may be used only by specially trained and authorized personnel.  
 Any tampering with the machine or alterations not approved beforehand by the Manufacturer relieve the latter of responsibility for any damage resulting from the above actions.  
 The removal of or tampering with the safety devices constitutes a violation of the European Standards on safety.



ALL WORK ON THE ELECTRIC PLANT, HOWEVER SLIGHT, MUST BE CARRIED OUT BY PROFESSIONALLY SKILLED PERSONNEL.

5.0 DESCRIPTION OF DANGER SIGNALS

				
1) Dangerous electricvoltage	2) Air not fit for breathing	3) High pressure	4) Fan rotating	5) Hot parts

6.0 DANGER ZONES

6.1 DANGER ZONES

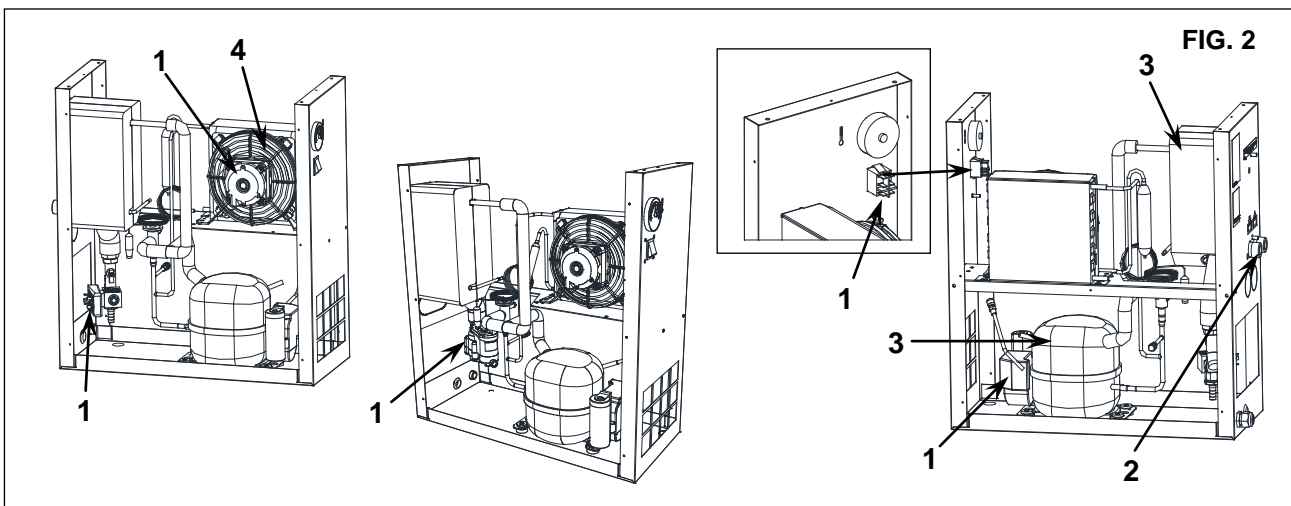
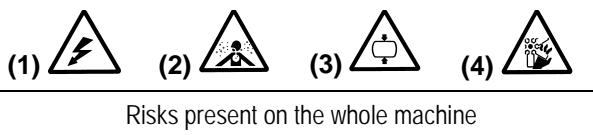

7.0 SAFETY DEVICES

7.1 SAFETY DEVICES

1) Cooling fan shield	
2) Earth	

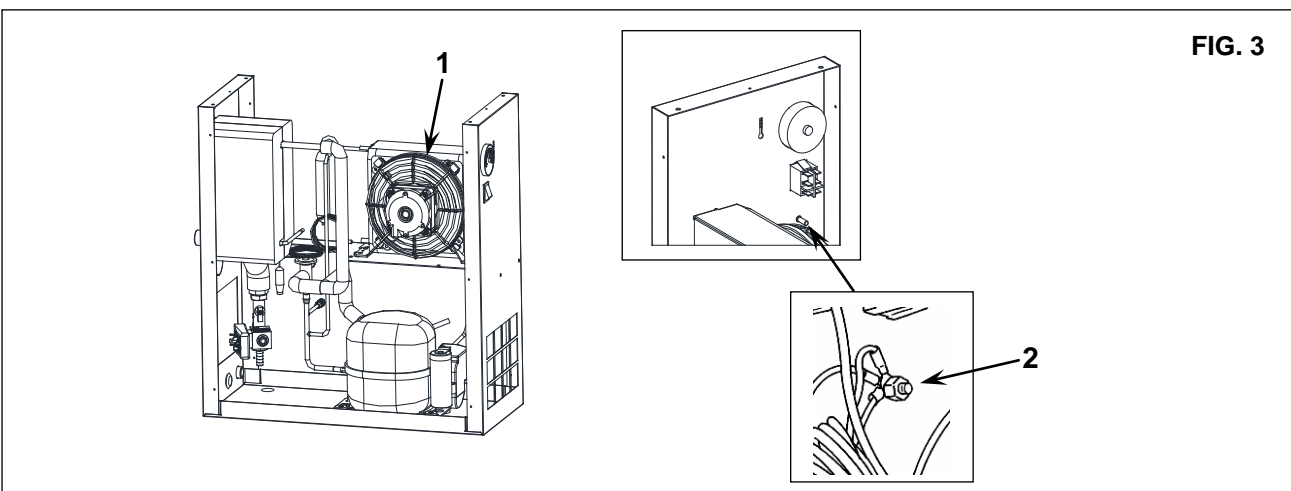

## ENGLISH

### 8.0 POSITION OF PLATES

#### 8.1 POSITION OF THE DANGER PLATES (Fig. 4)

The plates fitted on the compressor unit are part of the machine; they have been applied for safety purposes and must not be removed or spoiled for any reason.

Ref.1 - Warning label Code 1079 9903 48

FIG. 4

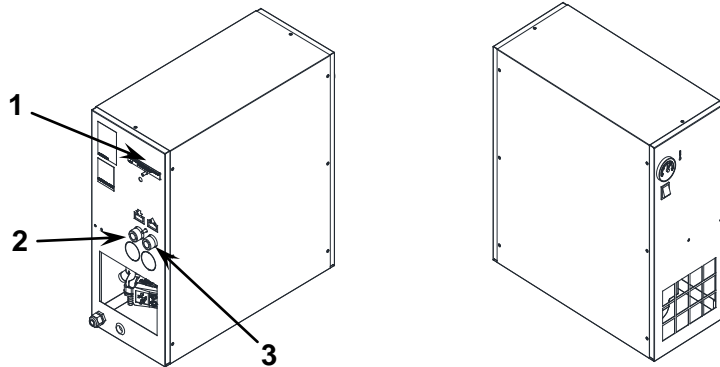

#### 8.2 POSITION OF THE DATA PLATES (Fig. 4)

Ref. 2) "IN"	Ref. 4) Identification plate
Ref. 3) "OUT"	

**FIG. 5**

MODD.	NET WEIGHT Kg. (lb)
C 15	19 (42)
C 25	19 (42)
C 35	19 (42)
C 50	20 (44)
C 60	25 (55)
C 75	27 (59)
C 100	30 (66)

### 9.0 DRYERS ROOM

#### 9.1 FLOOR

The floor must be even and of industrial type; the total weight of the machine is shown in Fig. 5. Remember the total weight of the machine when positioning it.

#### 9.2 VENTILATION

The choice of an appropriate room will prolong the life of your dryer; the room must be spacious, dry, well ventilated and free from dust. The operating conditions to be complied with are the following:

Min. room temperature: + 5 °C (41 °F) (compulsory)	Min. temperature of incoming air: 10 °C (50 °F)
Max. room temperature: + 40 °C (104 °F) (compulsory)	Max. working pressure: 16 bar (232 psi)
Max. temperature of incoming air: 50 °C (122 °F)	

### 10.0 TRANSPORT AND HANDLING

The machine must be transported as shown in the following fig. 5.

#### 11.0 UNPACKING



**CUTTING THE METAL STRAPPING IS A DANGEROUS OPERATION, DO NOT ABANDON THE CUT PIECES IN THE ENVIRONMENT.**

After removing the packing, ensure that the machine is unbroken and that there are no visibly damaged parts.

If you are in doubt, do not use the machine but apply to the manufacturer technical assistance service or to your dealer.

The packing material (plastic bags, polystyrene foam, nails, screws, wood, metal strapping, etc.) must not be left within the reach of children or abandoned in the environment, as they are a potential source of danger and pollution. Dispose of these materials in the approved collection centres.

### 12.0 INSTALLATION

#### 12.1 POSITIONING

After unpacking the equipment and preparing the dryers room, put the machine into position, checking the following items:

- ensure that there is sufficient space around the machine to allow maintenance (see Fig. 6).

**ENSURE THAT THE OPERATOR CAN SEE THE WHOLE MACHINE FROM THE CONTROL PANEL AND CHECK THE PRESENCE OF ANY UNAUTHORIZED PERSONS IN THE VICINITY OF THE MACHINE.**

#### 12.2 ELECTRICAL CONNECTION

- Check that the supply voltage is the same as the value indicated on the machine data plate.
- Check the condition of the line leads and ensure that there is an efficient earth lead.
- Ensure that there is an automatic cut-out device upstream for the machine against overcurrents, with a differential device ( Ref. 1 Fig. 6 ), wiring diagram.



ONLY PROFESSIONALLY SKILLED PERSONNEL MAY HAVE ACCESS TO THE ELECTRIC PANEL. SWITCH OFF THE POWER BEFORE OPENING THE DOOR OF THE ELECTRIC PANEL. COMPLIANCE WITH THE REGULATIONS IN FORCE CONCERNING ELECTRIC PLANTS IS FUNDAMENTAL FOR OPERATOR SAFETY AND FOR THE PROTECTION OF THE MACHINE.

### 12.3 CONNECTION TO THE COMPRESSED AIR NETWORK

Fit a manual interception valve between the machine and the compressed air network so that the dryer may be isolated during maintenance operations. Drainage of condensate Rif. 2 Fig. 7 (automatic) are led outside the machine with a flexible pipe that may be inspected. Drainage must comply with the local regulations in force.

ALL DAMAGE DUE TO THE FAILURE TO COMPLY WITH THESE INDICATIONS CANNOT BE ATTRIBUTED TO THE MANUFACTURER AND MAY CAUSE INVALIDITY OF THE GUARANTEE CONDITIONS.

### 12.4 STARTING UP

See part B of this manual, Chpter 18.0

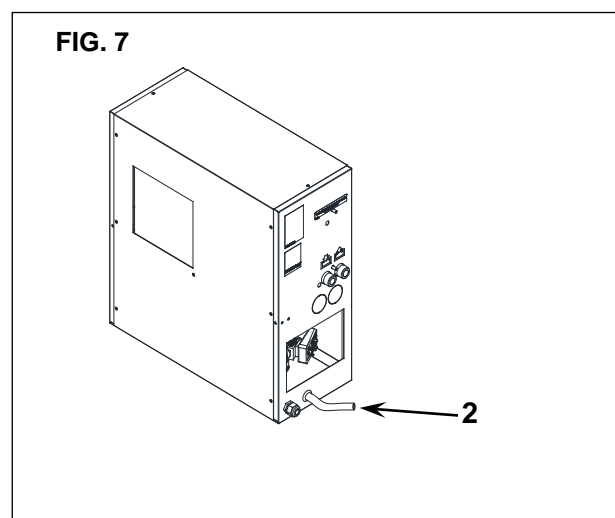
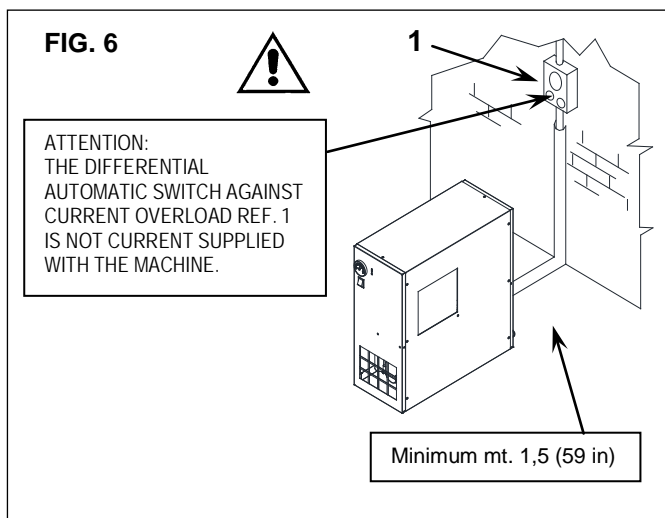

**13.0 DIMENSIONS AND TECHNICAL DATA**

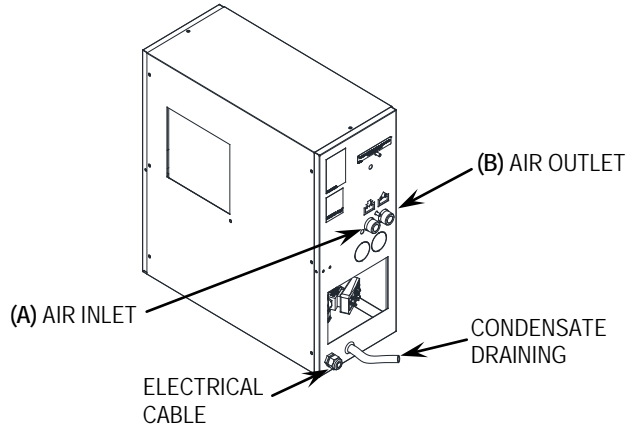
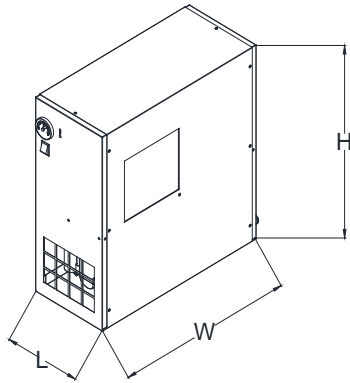

MODD.	DIMENSIONS mm (in)			Refrigerant gas <sup>(1)</sup>		GWP <sub>100</sub> <sup>(2)</sup>		MODD.	A	B
	L	W	H	R-134a		1300				
C15- C25- C35- C50- C75- C100	233 (9,17)	566 (21,8)	560 (22)	<sup>(1)</sup> According to ISO 817				C15-C25- C35-C50- C75-	3/4" GAS (CE) 3/4" NPT (cULus)	3/4" GAS (CE) 3/4" NPT (cULus)
				<sup>(2)</sup> According to EN-378-1				C100	1" GAS (CE) 1" NPT (cULus)	1" GAS (CE) 1" NPT (cULus)

TYPE	Weight Kg. (lb)	V230 Freon R134a Kg. (lb)		Nominal Power W (hp)		Nominal Power W (hp)		Nominal Power W (hp)		Bar (psi) MAX. 
		50 Hz	60 Hz	50 Hz	60 Hz	50 Hz	60 Hz	50 Hz	60 Hz	
<b>C15</b>	19 (42)	0,150 (0,33)	0,170 (0,37)	97 (0,13)	116 (0,15)	29 (0,03)	44 (0,05)	126 (0,16)	160 (0,21)	bar 16 (232)
<b>C25</b>	19 (42)	0,170 (0,37)	0,170 (0,37)	97 (0,13)	118 (0,15)	29 (0,03)	42 (0,05)	126 (0,16)	160 (0,21)	bar 16 (232)
<b>C35</b>	19 (42)	0,170 (0,37)	0,230 (0,50)	134 (0,17)	125 (0,16)	29 (0,03)	49 (0,06)	163 (0,21)	174 (0,23)	bar 16 (232)
<b>C50</b>	20 (44)	0,290 (0,63)	0,290 (0,63)	199 (0,26)	139 (0,18)	29 (0,03)	49 (0,06)	228 (0,30)	188 (0,25)	bar 16 (232)
<b>C60</b>	25 (55)	0,350 (0,77)	0,350 (0,77)	260 (0,34)	248 (0,33)	33 (0,05)	54 (0,07)	293 (0,39)	302 (0,40)	bar 16 (232)
<b>C75</b>	27 (59)	0,500 (1,10)	0,430 (0,94)	347 (0,46)	404 (0,54)	33 (0,05)	54 (0,07)	380 (0,50)	458 (0,61)	bar 16 (232)
<b>C100</b>	30 (66)	0,400 (0,88)	0,420 (0,92)	359 (0,48)	397 (0,53)	60 (0,08)	54 (0,07)	419 (0,56)	451 (0,60)	bar 16 (232)

TYPE	Weight Kg. (lb)	V115 Freon R134a Kg. (lb)		Nominal Power W (hp)		Nominal Power W (hp)		Nominal Power W (hp)		Bar (psi) MAX. 
		50 Hz	60 Hz	50 Hz	60 Hz	50 Hz	60 Hz	50 Hz	60 Hz	
<b>C15</b>	19 (42)		0,170 (0,37)		117 (0,15)		27 (0,05)		144 (0,19)	bar 16 (232)
<b>C25</b>	19 (42)		0,170 (0,37)		117 (0,15)		27 (0,05)		144 (0,19)	bar 16 (232)
<b>C35</b>	19 (42)		0,270 (0,58)		126 (0,16)		27 (0,05)		153 (0,21)	bar 16 (232)
<b>C50</b>	20 (44)		0,29 (0,64)		168 (0,18)		24 (0,03)		192 (0,26)	bar 16 (232)
<b>C60</b>	25 (55)		0,40 (0,87)		277 (0,33)		24 (0,03)		301 (0,40)	bar 16 (232)
<b>C75</b>	27 (59)		0,50 (1,08)		361 (0,54)		46 (0,06)		407 (0,55)	bar 16 (232)
<b>C100</b>	30 (66)		0,42 (0,91)		537 (0,53)		46 (0,06)		583 (0,78)	bar 16 (232)

  

Reference conditions:	Limit conditions:
Ambient temperature 25 °C (77 °F)	Max. ambient temperature 40 °C (104 °F)
Inlet air temperature 35 °C (95 °F)	Min. ambient temperature 5 °C (41 °F)
Working pressure 7 bar (101 psi)	Max. inlet air temperature 50 °C (122 °F)
	Max. working pressure 16 bar (232 psi)

14.0 MACHINE ILLUSTRATION

14.1 GENERAL LAY-OUT

FIG. 8

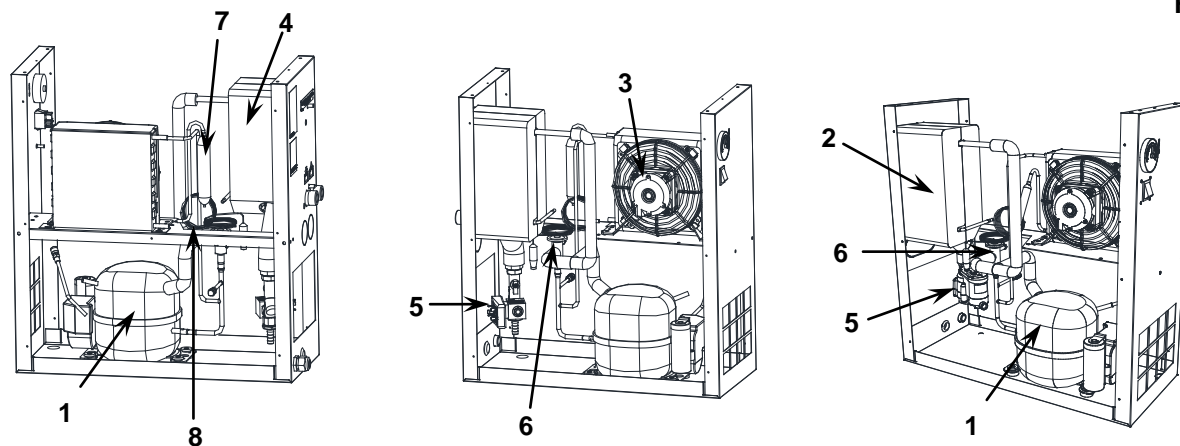

1	Refrigerant compressor
2	Condenser
3	Motor fan
4	Evaporator
5	Condensate drain
6	Hot gas by-pass valve
7	Refrigerant filter
8	Expansion capillary tube

14.2 COMMAND AND CONTROL PANEL

BEFORE CARRYING OUT THE OPERATION TEST, READ CAREFULLY AND ACQUIRE A GOOD KNOWLEDGE OF THE COMMAND FUNCTIONS.

- Ref. 1) Dew point indicator
- Ref. 2) Stop - Running button

FIG. 9

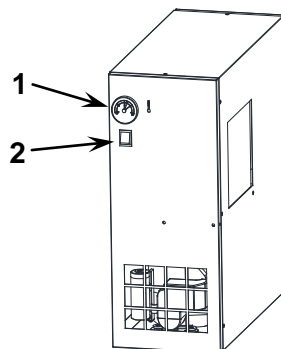

15.0 PARTIAL ROUTINE MAINTENANCE



BEFORE CARRYING OUT ANY MAINTENANCE JOBS IT IS OBLIGATORY TO STOP THE MACHINE AND DISCONNECT IT FROM THE POWER MAINS AND FROM THE COMPRESSED AIR DISTRIBUTION NETWORK.

15.1 MAINTENANCE SCHEDULE

These maintenance intervals are recommended for work environments that are not dusty and are well ventilated. For particularly dusty environments, double the frequency of controls.

**Each Week**

Condensate drain: Clean the filter of the steam trap

**Each Monthly**

Condenser: Clean the condenser fins to remove eventual dust.

**15.2 CLEANING OF THE AUTOMATIC CONDENSATER DISCHARGER FILTER (Fig. 10)**

Clean the filter of the steam trap.

Proceed as follows:

- Close the cock Ref. 1 Fig. 10
- Release the pressure in the dryer by pressing the condensate drain "TEST" pushbutton locate on the steam trap Ref. 2 Fig. 10.
- Switch off the machine by pressing the STOP button Ref. 3 Fig. 10
- Turn on the supply automatic differential switch Ref. 4 Fig. 10

**HOT PARTS INSIDE**

- Remove the panel Ref. 5
- Remove the stopper Ref. 6
- Remove the filter Ref. 7
- Clean the filter Ref. 7 with a jet of air, working from inside to outside
- Install the filter, fix the plug Ref. 7 - 6
- Close the panel Ref. 5

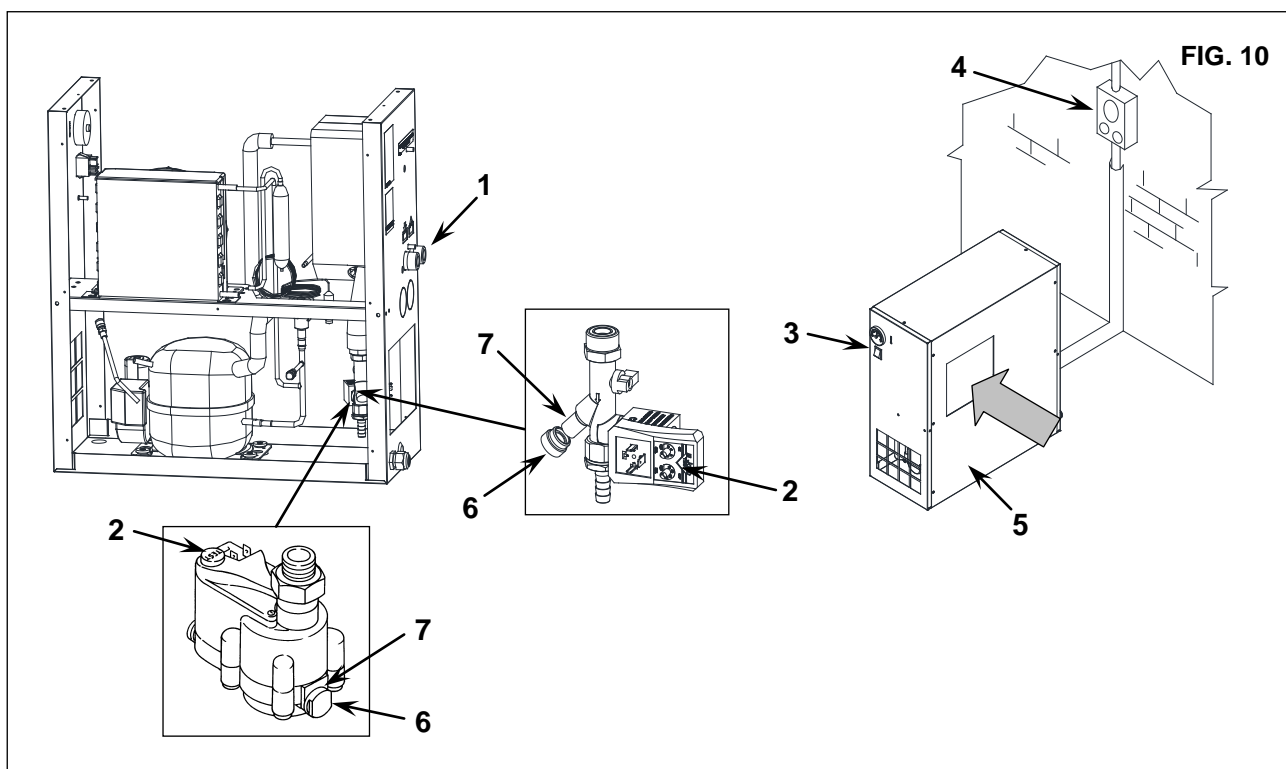

**15.3 CLEANING THE CONDENSER (Fig. 10)**

The condenser must be cleaned every month.

Proceed as follows:

- Switch off the machine by pressing the STOP button Ref. 3 Fig. 10
- Turn on the supply automatic differential switch Ref. 4 Fig. 10
- Remove the panel Ref. 5 Fig. 10
- Clean the condenser fins Ref. 1 with compressed air (Fig. 10) **DO NOT USE WATER OR SOLVENTS**
- Close the panel Ref. 5 Fig. 10

**16.0 SCRAPPING THE UNIT**

If the machine is to be scrapped, it must be dismantled into parts of the same material, to be disposed of according to the local regulations in force.

**ALWAYS RESPECT THE REGULATIONS IN FORCE FOR DISPOSING OF OLD OIL AND OTHER POLLUTING MATERIALS SUCH AS INSULATING FOAM, ETC.**



## 17.0 TROUBLE-SHOOTING AND EMERGENCY REMEDIES



ALL WORK MUST BE CARRIED OUT BY PROFESSIONALLY SKILLED PERSONNEL. BEFORE CARRYING OUT ANY MAINTENANCE JOBS IT IS OBLIGATORY TO STOP THE MACHINE AND DISCONNECT IT FROM THE POWER MAINS.

N.B. OPERATIONS MARKED ■ ■ MUST BE CARRIED OUT BY PROFESSIONALLY SKILLED PERSONNEL APPROVED THE MANUFACTURER

FAULT FOUND	POSSIBLE CAUSES	OBSERVATIONS
1) No compressed air passes through the dryer outlet	1A) The pipes are frozen inside	<ul style="list-style-type: none"> <li>■ ■ -The bypass valve of the hot gas is broken or out-of-calibration</li> <li>-The room temperature is too low and the evaporators piping are obstructed with ice</li> </ul>
2) Presence of condensate in the pipings.	2A) The condensate separator does not work correctly  2B) The dryer is working outside its rating  2C) The dryer is working under bad conditions of condensation	<ul style="list-style-type: none"> <li>- Clean the filter from the condensate drain</li> <li>■ ■ -Check the condensate drain</li> <li>-Check the flow rate of treated air</li> <li>-Check the room temperature</li> <li>-Check the air temperature at the drier inlet.</li> <li>-Clean the condenser.</li> <li>■ ■ -Check the operation and the calibration of the press. Switch (only mod. C6).</li> <li>■ ■ -Check the good operation of the fan.</li> </ul>
3) The compressor head is very hot (> 55 °C) (131 °F)	Make reference to 2B Make reference to 2C 3A) The cooling circuit is not working with the right gas charge	<ul style="list-style-type: none"> <li>■ ■ -Check if there are leaks of refrigerating gas.</li> <li>■ ■ - Charge it again.</li> </ul>
4) Motor cuts out on overload	Make reference to 2B Make reference to 2C Make reference to 3A	
5) The motor hums and does not start.	The line voltage is too low. You switched the machine off and on again without leaving enough time for the pressure balancing. The starting system of the motor is defective.	<ul style="list-style-type: none"> <li>-Contact the electric power company</li> <li>-Wait a few minutes before starting the machine again.</li> <li>■ ■ -Check the running and starting relays and condensers (if any)</li> </ul>
6) The machine has stopped and does not restart even after a few minutes.	The overload protection with has intervened: make reference to 2B-2C-3A.  The motor has burnt out.	
7) The compressor is very noisy.	Troubles with the internal mechanical parts or with the valves	

## PART "B"



**THIS PART "B" OF THE INSTRUCTIONS MANUAL IS RESERVED FOR PROFESSIONALLY SKILLED PERSONNEL APPROVED THE MANUFACTURER.**

## 18.0 STARTING UP

BEFORE CARRYING OUT ANY OPERATION ON THE MACHINE, ENSURE THAT THE ELECTRIC POWER SUPPLY HAS BEEN DISCONNECTED

## 18.1 PRELIMINARY CONTROLS

Before starting the dryer, check:

- The correct connection to the compressed air piping; remember to remove eventual caps on the drier inlet and outlet.
- The correct connection to the condensate drainage system.
- That the power supply is right.

## 18.2 STARTING AND STOP

Start the system before the air compressor starts running and stop it after the air compressor has been stopped. The compressed air piping will be free of condensate only by doing so. The drier must be kept running during all the time the air compressor is running. **WARNING:** if the drier is switched off, before starting it again, wait at least 5 minutes in order to allow the pressure balancing.

BEFORE CARRYING OUT ANY MAINTENANCE JOBS IT IS OBLIGATORY TO STOP THE MACHINE AND DISCONNECT IT FROM THE POWER MAINS AND FROM THE COMPRESSED AIR DISTRIBUTION NETWORK.

**PRESSURE DISCHARGE PROCEDURE (Fig. 10)**

Proceed as follows:

- Close the taps Ref. 1 Fig. 10
- Release the pressure in the dryer by pressing the condensate drain "TEST" pushbutton locate on the steam trap Ref. 1 Fig. 10
- Switch off the machine by pressing the STOP button Ref. 3 Fig. 10
- Turn on the supply automatic differential switch Ref. 4 Fig. 10

**CALIBRATIONS**

**BYPASS VALVE FOR HOT GAS**

N.B. These valves have already been calibrated and they do not require any adjustment. A dew point different from the rated one generally depends on causes which are not attributable to their operation.

- Ref. 1) Closing cap
- Ref. 2) Adjusting screw

**WORKING PRESSURES AND TEMPERATURES OF R134A**

SUCTION SIDE OF REFRIGERATION COMPRESSOR		
	Evaporat. Temperat. °C (°F)	Evaporating Pressure bar (psi)
RATED VALUES (Temperat. 20°C - 68°F)	1 ÷ 2 (33,8 ÷ 35,6)	R134A 2,1 ÷ 2,3 (30,4 ÷ 33,3)

