

**ELGI**<sup>TM</sup>

Always Better.

# EG Series Screw Air Compressor

Operation, Maintenance and Parts Manual



**EG 11, Standard + VFD**  
**460V, 3Ph, 60Hz**

CIN:L29120TZ1960PLC000351





# Product Manual

**EG Series**

**Electric Powered Screw Air Compressor**

**EG 11 - 150.0, 175.0**

Air - Cooled, Standard + VFD  
460V, 3Ph, 60Hz

©

**ELGI EQUIPMENTS LIMITED**

Coimbatore, TN - 641 005

Part / Document No. 019000381

**Contact Info:**

**ELGI EQUIPMENTS LIMITED**

Coimbatore, TN - 641 005, India

Tel : 91 - 422 2589555

Fax : 91 - 422 2573697 (Domestic Business)

Fax : 91 - 422 2589401 (International Business)

E-mail : enquiry@elgi.com

Website : www.elgi.com

# Machine Identification and Sale Record



Owner's name / Company name : .....

Phone number : .....

Contact person : .....

E-Mail address/ Phone number : .....

Model : .....

Fab. No. : .....

Year of manufacture : .....

Motor : ..... kW (HP)

Capacity : ..... m<sup>3</sup>/min (cfm)

Rated pressure : ..... bar.g (psi.g)

Date of delivery : .....

Date of commissioning : .....

Dealer name/address : .....

Dealer's signature : .....

**NOTE** *The warranty on the compressor is valid only if all the details above are filled in and the dealer stamps and signs this page. This report must reach the Regional Office/Head Office of ELGi within seven days of commissioning date.*

	<b>Chapter</b>	<b>Page No.</b>
1.0	About ELGi	1.7
2.0	General functional description	2.1
3.0	GA drawing, P&I diagram	3.1
4.0	Technical data	4.1
5.0	Installation and operation	5.1
6.0	Maintenance	6.1
7.0	Controller	7.1
8.0	Air inlet and control system	8.2
9.0	Drive system	9.1
10.0	Discharge system	10.1
11.0	Cooling system	11.1
12.0	Lubrication system	12.1
13.0	Base and canopy system	13.1
14.0	Spare kit details	14.1
15.0	Electrical drawings	15.1
16.0	VFD settings	16.1

ELGi, established in 1960, designs and manufactures a wide range of air compressors. The company has gained its reputation for design and manufacture of screw compressors through strategic partnerships and continuous research and development. Over the years, it has emerged as a multi-product, multi-market enterprise providing total compressed air solutions to all segments. ELGi's design capabilities translated into a wide range of products ranging from oil-lubricated and oil-free rotary screw compressors, reciprocating compressors and centrifugal compressors.

ELGi is one of the few companies in the world capable of manufacturing wide range of air ends and compressor packages. ELGi has most modern manufacturing facilities with high precision grinding machines, turning centres, CNC horizontal and vertical machining centres and also the latest self measurement technology to maintain precise, aerospace manufacturing tolerances. ELGi's manufacturing plants are ISO and EOHS certified.

Over two million ELGi compressors are powering business in 70+ countries worldwide. The company offers a strong sales and service network with a well-knit distribution network of dealers and distribution, worldwide. ELGi has its own manufacturing operations in India, Italy and USA with subsidiary offices in Australia, Bangladesh, Brazil, China, Indonesia, Italy, Malaysia, Middle East, Sri Lanka and Thailand. The company is fast expanding its global footprint, attracting distributors and customers with its new generation products.

### Need help...?

#### In India

You can contact ELGi customer care system (ECCS) to take care of customer complaints. The ELGi CCS works for six days a week from 08:30 to 21:30 IST (Monday to Saturday). The complaints can be logged by calling any of the following toll free numbers or by e-mail.

**Toll free** : **1800 425 3544**

**E-Mail** : [ccs@elgi.com](mailto:ccs@elgi.com)

**Website** : [www.elgi.com](http://www.elgi.com)

Before making service request for your compressor, keep ready the details printed on the name plate of the compressor and machine identification and sale record of this manual. When ordering spare parts, refer to the lists provided in the parts manual and identify the part number. Specify the part number and quantity, in addition to the name plate details.

Refer "ELGi services" for more details about ECCS under chapter "Maintenance".







<b>Contents</b>	<b>Page No.</b>
<b>2.1 Using the manual</b>	<b>2.2</b>
2.1.1. Definitions and symbols	2.2
<b>2.2 Introduction</b>	<b>2.3</b>
<b>2.3 Safety</b>	<b>2.4</b>
2.3.1 Precautions during installation	2.4
2.3.2 Precautions during operation	2.5
2.3.3 Precautions during maintenance	2.7
<b>2.4 Functional description</b>	<b>2.9</b>
2.4.1 Air circuit	2.9
2.4.2 Oil circuit	2.9
2.4.3 Drive system	2.9
2.4.4 Control system	2.10
2.4.5 For retro-fitment of Standalone VFD with Compressor (C) version in field	2.10

## 2.1 Using the manual

This operation and maintenance manual has been specially designed keeping the customer in mind so that the person can get the most out of this EG compressor. Before starting the compressor, it is requested that the manual should be read thoroughly. It contains vital information about installation, commissioning, operation and useful tips on maintenance to keep the compressor as good as new, year after year. The manual has been prepared with utmost care to help you understand the various systems of the compressor, along with descriptions, information and illustrations.

Following chapters are provided to help operate the compressor in its best way.

- **Safety** - safety precautions that must be followed while using the compressor.
- **Technical specifications** - technical details about the compressor.
- **Installation and commissioning** - all site requirements, procedures to be followed during installation, commissioning, preservation etc.
- **Functional description** – parts, their function and working.
- **Operating instructions** – to operate the compressor properly.
- **Maintenance** – how to do the maintenance for the compressor and their intervals.
- **Troubleshooting** – identification and solving the problems.
- **Decommissioning** – how to decommission the compressor, its disposal etc.
- **ELGi services** – services from ELGi: CCS, air audit, spare parts
- **Appendix** – conversion tables, torque values, service log book

Refer to the parts manual to identify the part number of the required spare. Mention the Fab number, model and part number while ordering.

**This manual must be made available to the compressor operating and maintenance personnel at all times.**

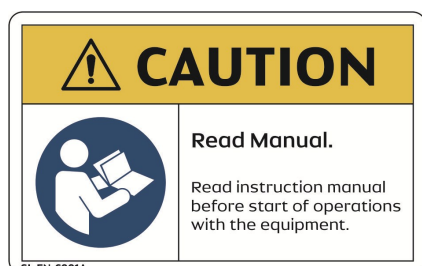

### 2.1.1 Definitions and symbols

This information is related to your safety and also to prevent any problems relevant to the equipments used. To help recognize this information better, the symbols are illustrated in section "safety".

All the information, illustrations and specifications in this manual are based on the latest product information at the time of preparation of the manual. Product improvement is a continuous process in ELGi. The details in this manual are likely to change without notice and ELGi reserves the right to incorporate such changes.

#### NOTE

*Note clarifies procedures or conditions which may otherwise be misinterpreted or overlooked. Note may also be used to clarify apparently contradictory or confusing situations.*

#### WARNING

*Warning calls attention to dangerous or hazardous conditions inherent to the operation, cleaning and maintenance of the compressor which may result in fatal accident and personal injury of the operator or other staff*

#### CAUTION

*Caution is to draw attention to a procedure which, if not done correctly can lead to compressor damage.*

Welcome to ELGi customer family. ELGi compressors are the source of compressed air in various segments across the globe.

ELGi compressors are known for

- Greatest reliability
- Fewer maintenance interval
- Ease of use
- Highest safety

ELGi screw compressor is designed to give

- High energy efficiency
- Low maintenance cost
- High discharge air quality

All the above assures a low life-cycle cost.

The rotors incorporate a specially designed **eta-v profile** – ELGi patented profile-which emphasizes on improving reliability, performance and efficiency. Eta-v profile is the latest and the most energy efficient profile in the industry globally, assuring consistent performance during entire life of the compressor. ELGi screw air compressors have a compact design and compressor run with low noise or vibrations. The capacity control system ensures optimum air intake during start up, normal running and unloading stages, minimizing power consumption. The oil separation system ensures that maximum oil is separated from the compressed air, ensuring the best air quality with very little oil carry-over.

### Uptime

At ELGi, we are changing the way you look at compressed air systems. It's no longer just about delivering air. It's about delivering uptime. Our uptime design ensures that the compressors would run cooler, cleaner and longer with longer service intervals. The uptime components are bests in quality keeps your compressor to run smoothly, efficiently and profitably. With uptime assurance we back our pledge, with industry-leading warranties, parts availability, loaner compressors and call centres staffed by experts. We thank you for purchasing ELGi compressor and assure you the best service during entire life of compressor.

### EG Series

Your EG Series compressor belongs to a family of rotary screw compressors from ELGi. The compressor has only two moving parts: the two rotors. A thin film of oil separates the rotors to prevent wear. This also means that the reliability of the compressor is unsurpassed.

The screw compressor technology ensures that output capacity never diminishes even after many years of operation. It involves a continuous flow of air through helical cavities in the screw, ensuring pulsation-free compressed air delivery.

The design of the EG Series gives you a compact and self-contained compressor. Because it contains no reciprocating parts, it runs quietly and free of vibrations. The discharge temperature of the coolant oil is low, less than 90°C (195°F), under normal conditions and therefore prevents carbonized oil from forming in the compressor.

### Salient Features

- Three-stage air filtration
- Improved air filter life cycle
- Noise-free package suitable for in-house operations
- Variable capacity control system\*
- High volumetric efficiency
- Efficient air-oil separation by OSBIC (Oil Separation By Impact and Centrifugal action)
- Reliable fan that works even at high temperature
- Isolated cooling system
- Robust cooling system
- Industrial designed canopy
- Compact and hardly space-intensive
- Split type oil & after coolers for easy serviceability
- Flush type panels for easy handling
- Anti-vibration mounts for restricted vibration
- Increased life of consumables
- Integrated VFD (Variable Frequency Drive) and dryer\*.
- Zero-leak flanged joints.
- Oil carry over < 1 ppm
- Advanced Neuron controller
- Globally certified product - CE / UL and other country specific approvals.

\* For selected models.

The operator must follow the safe working practices, instructions, procedures that this manual describes for safe operation. The maintenance personnel must be adequately trained, and have read and thoroughly understood this 'Operation and maintenance manual'. Decals are affixed at specific locations of the compressor and they illustrate very important safety precautions.

### 2.3.1 Precautions during installation

- Ensure that you fasten all loose parts before lifting. Select the appropriate lifting equipment by considering the local safety regulations, size and weight of the compressor. Operate the lifting equipment carefully within the safe operating limits. Ensure all necessary personal protective equipment's (PPEs) is close at hand during this operation.



- Maintain a cool and clean ambient for the compressor and ensure that the air inlet is not obstructed. Make arrangements to reduce the moisture entry through the incoming air.
- Remove protection such as caps, plugs, desiccant bags before connecting the air line pipes.
- Remove the red colored protective clamps from the aircend and motor while commissioning the compressor.



- Do not use frayed, damaged or worn hoses. Distribution pipes and connections must be of the correct size and suitable for working pressure.
- Make sure that the aspirated air by the compressor is free of flammable fumes, vapors and particles, to prevent internal fire or explosion.
- For remotely controlled compressors and auto-start compressors, provide a clear caution stating: **"DANGER" – Remotely controlled machine and will start without notice**



- Ensure the operator is located far away from the intake of the compressor.
- Position the after-cooler discharge pipe in a way that it is free to expand under heat and is not in contact with or close to flammable materials.
- Do not exert external force on the air outlet valve and keep the connected pipe always free of strain.
- Make available adequate cooling air must be made available for the compressor particularly air cooled compressors. Make sure that exhausted air does not circulate back to the intake or cooling system.
- Make the electrical connections according to the legal standards and earth the compressor suitably. Provide a sufficient number of fuses and other protective devices to protect the compressor against short circuits. Good practice is to provide an isolating switch nearby the compressor.
- Install manual valves behind non-return valves (NRV) to isolate each compressor in multi-compressor systems. Do not rely on NRV for isolating pressure systems.
- Do not bypass, remove or adjust the safety devices or other attachments residing on the compressor. Every installed pressure vessel or auxiliary outside the compressor should have pressure relieving device or devices, as required.

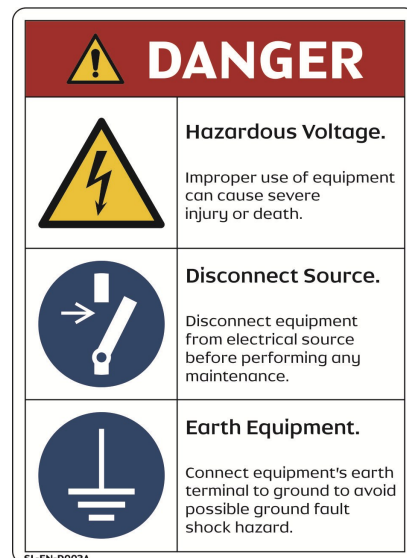

- Danger! Be aware that compressed air used for breathing or food processing must meet O.S.H.A.

1910.134 or F.D.A. 21 C.F.R. 178.3570 regulations. Failure to do so may cause severe injury or death.

- Insulate or use protective guards to cover pipes or other parts that may exceed 80°C (176°F). High-temperature pipes must have a clear marking as potentially dangerous.
- Position the compressor on level surface. In case of inclined surface, contact ELGi.
- Do not allow compressed air to come in contact with food and related items unless they are compressed air-treated specifically.
- Be aware that this air compressor is intended for generating only industrial-use compressed air.

### 2.3.2 Precautions during operations

- When switching on remotely controlled compressors ensure that no one is checking or working on the compressor at that time.
- Before starting, ensure that no tools or any loose parts remain inside the compressor.
- Do not operate the compressor if a possibility exists that it could inhale flammable or toxic fumes, vapors or particles.
- Do not operate the compressor below or above its operating limits.
- Wear ear protectors if you work in an environment where the sound pressure level reaches or exceeds 90 dB (A).
- Keep all the compressor doors shut during operation. For carrying out routine checks, the doors should open only for short durations not more than 10 minutes. Wear ear protectors when opening a door.
- Keep hands, feet, floors, controls and walking surfaces clean and free of water or other liquid to minimize the possibility of slips and falls.

### Pressure release

- Know that annual servicing of the safety valve is necessary. It should be checked at the prescribed pressure for operation.
- Use correct tools for maintenance and repair work. Do not allow the manufacturers' rated safe operating pressure to exceed for pipes, valves, filters and other fittings.
- It is hazardous to point the compressed air directly towards any personnel. Keep personnel out of the line of the discharge air when opening hoses or other points of compressed air discharge.
- Use only the correct type and size of hose end fittings and connections. When blowing through a hose or airline ensure that the open end stays securely. A free end will whip and may cause injury. Make sure to

depressurize a hose fully before disconnecting it.

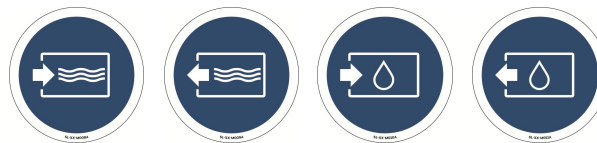

- Release all the pressure in the compressor system before servicing or performing any maintenance activity.
- Do not engage in horseplay with air hoses. Serious injury or death may result.
- Do not use air at a pressure greater than 2.5 bar.g (36 psi.g) for cleaning purpose.
- Open the oil fill cap only when the compressor is not running and is not pressurized. Shut down the compressor and bleed the receiver tank to zero internal pressure before removing the cap.

### Fire and explosion



- Clean up spills of lubricants or other combustible substances immediately.
- Shut down the compressor and allow it to cool down before checking or adding oil. Remove sparks, flames and other sources of ignition away from the compressor.
- Do not permit smoking in the vicinity of the compressor.
- Do not use flammable solvents for cleaning purposes.
- Keep electrical wiring and other terminals in good condition. Replace any wiring that has cracked, cut, abraded or otherwise degraded insulation. Keep all terminals clean and tight.
- Keep grounded conductive objects such as tools away from exposed live electrical parts like terminals to avoid arcing, which might serve as a source.
- Keep oily rags, trash, dry leaves, litter or other combustibles out of and away from the compressor.
- Do not operate the compressor without a proper flow of cooling air or with an inadequate flow of lubricant or with a degraded lubricant.
- Do not attempt to operate the compressor in a hazardous environment of any classification unless the compressor has been specially designed and manufactured for explosive applications.

**Moving Parts**

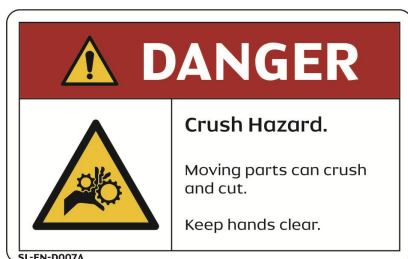

- Rotating fan blades can cause serious injury. Disconnect power supply before attempting service.
- Keep compressor doors closed except when servicing or during maintenance. The sound damping material on the inner side of the compressor body should not be removed or tampered with.
- Wear snug-fitting clothing and tie long hair when working around the compressor, especially when hot or moving parts such as the cooler, the airend, the thermal valve, the main motor or the fan motor are exposed.
- Keep hands, arms and clothing away from couplings, fans/belts and other moving parts.
- Do not attempt to operate the compressor with the fan guards, coupling guards/belt guards or other guards removed.



- Keep hands, feet, floor, controls and walking surfaces clean and free of fluid, water or other liquids to minimize the possibility of slips and falls.

**Hot surfaces**



- Avoid bodily contact with hot oil and hot surfaces like cooler, pipes etc.
- Keep all parts of the body away from all points of air discharge.
- Keep a first aid kit handy. Seek medical assistance promptly in case of injury. Do not ignore small cuts and burns.

**Toxic and irritating substances**

- Do not use air from the compressor for breathing.
- Always wear safety equipment while operating the compressor. Refer OSHA safety standards.
- Do not allow compressed air to come into contact with any edible items.
- In the event of ingestion of oils, coolants or lubricants used in the compressor, seek medical treatment promptly. In case you come in contact with such substances, wash with soap and water. Use MSDS for oil to know more on this.
- If warm cooling air from the compressor is being used in air heating systems, e.g. to warm up a work room, take precautions against air pollution and possible contamination of the breathing air.

**Electric shock**

- Keep all parts of the body and any handheld tools or other conductive objects away from exposed live parts of the electrical system.
- Stand on a dry or insulating surface and do not contact any other part of the compressor when making adjustments or repairs to exposed live parts of the electrical system.





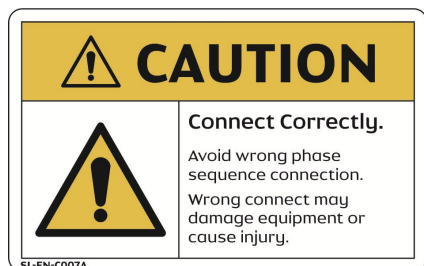

- Before switching on the compressor ensure that proper earthing is done as per recommendation.
- Make all adjustments or repairs with one hand. This minimizes the risk of creating a current path through the heart.
- Conduct repairs only in a clean, dry, well-lit and ventilated area.
- Do not leave the compressor unattended with open electrical enclosures. If necessary to do so, disconnect the power to the compressor at the source and lock it out so that power is not inadvertently restored.
- Disconnect, lock out, and tag the power source prior to attempting repairs or adjustments, turning the compressor manually or handling ungrounded conductors.
- All electrical installation must be in accordance with recognized electrical codes and any local health & safety codes.
- Recognize that only authorized and qualified trained personnel should carry out any electrical work on the compressor.
- Regularly check that all electrical connections are tight and in good condition.

**Periodically check whether**

- All guards are in place and securely fastened.
- All hoses and pipes inside the compressor are in good condition, secure and not rubbing against each other.
- Any leaks exists.
- All fasteners are tight.
- All electrical leads are secure and in good order.
- Safety valves and other pressure relief devices are not obstructed by dirt or paint.
- Air outlet valve, i.e. pipes, couplings, manifolds, valves, hoses, etc. are in good repair, free of wear or abuse.
- The air-oil tank is properly grounded.

**2.3.3 Precautions during maintenance**

- Use safety glasses and incorporate safe working practices before maintenance work.
- Use appropriate tools for all maintenance works.

- Use only genuine spare parts. Refer the **section "Use genuine spare parts"** in **"Maintenance"** chapter.

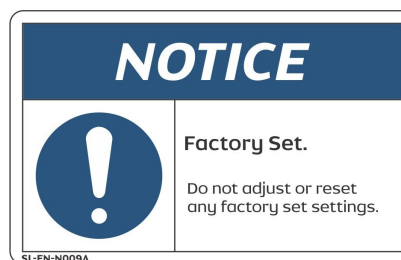

- Ensure that the compressor is cooled down before maintenance is performed.

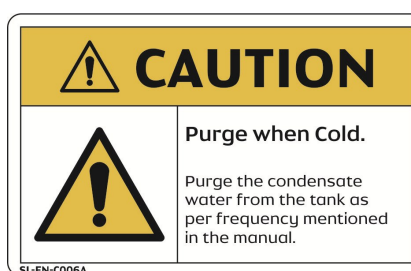

- Springs under tension or compression store energy. Uncontrolled release of this energy can cause serious injury or death. Be cautious while performing the maintenance of components loaded with springs (for example minimum pressure valve, safety valve etc.).
- Display a warning sign that says **"Maintenance under progress, don't switch on"** near the start switch.
- Isolate the compressor from the air line (discharge) and disconnect the power by opening and locking the isolating switch before maintenance.
- Prior to attempting repairs or adjustments, disconnect the power at the source and verify at the compressor that the circuits have de-energized. This minimizes the possibility of accidental start-up or operation, especially when the compressor is remotely controlled.
- Open the oil filler cap only when the compressor is not running and is not pressurized. Shut down the compressor and bleed the receiver tank to zero internal pressure before removing the cap.

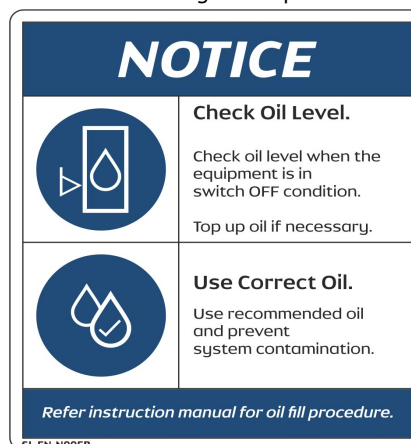

- If you are going to switch on remotely controlled compressors must ensure that nobody is checking or working on the compressor at that time. A warning sign near the equipment's start button is mandatory.
- Wait up to five minutes to ensure that the air in the air-oil separator tank is released to start routing maintenance.

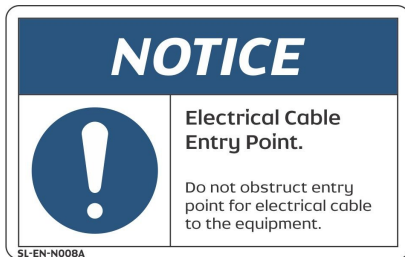

- Vent all internal pressure prior to opening any line, fitting, valve, drain plug, connection or other components such as filters. Vent pressure by popping up the safety valve.
- Display a maintenance chart near the compressor to easily identify the maintenance intervals of regular service items.

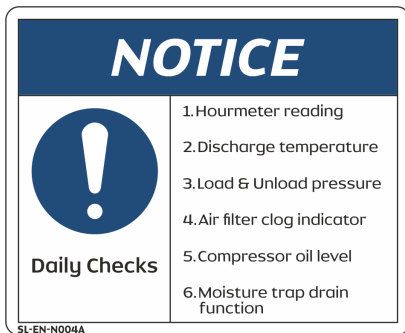



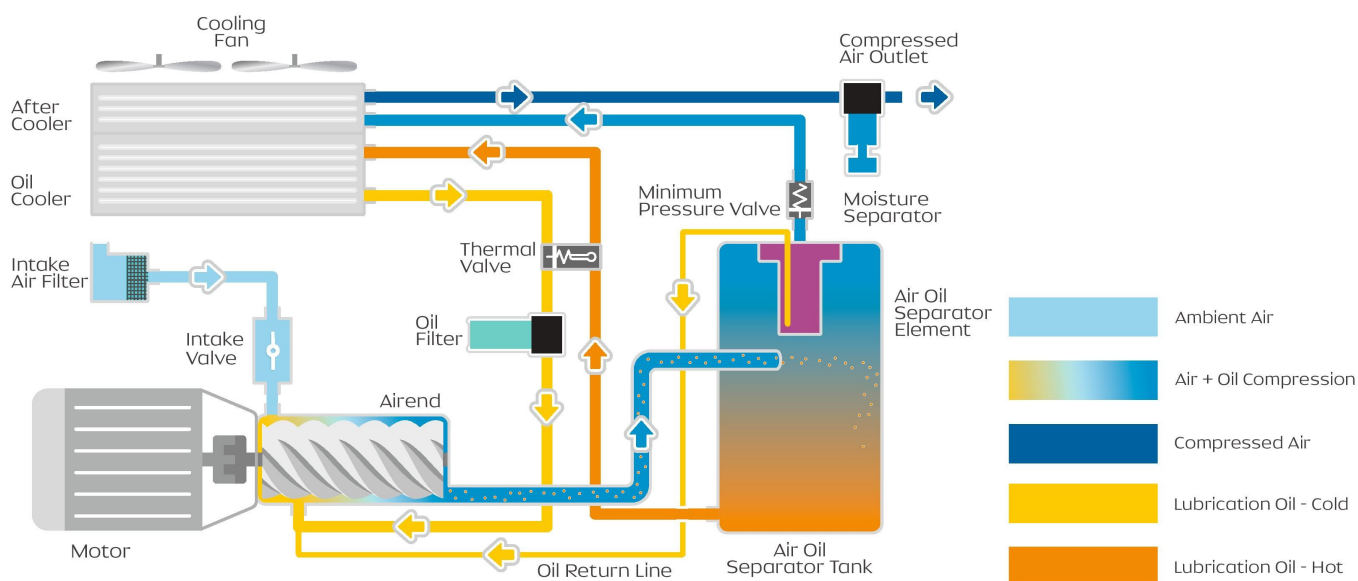

**Figure 1. Screw compressor systems - Schematic diagram**

### 2.4.1 Air circuit

The atmospheric air enters into the airend through the air intake system. The intake filters (pre filter and air filter) prevents the entry of foreign particles (such as dust) into the airend. The intake valve regulates the amount of air sucked into the airend. The opening and closing of the intake valve are controlled by the pneumatic pulse line actuated by an electrically controlled solenoid valve. The clog indicator fitted in the air filter turns red when the filter is clogged.

The filtered air enters into the airend where it mixes with the injected oil. The injected oil acts as a coolant to maintain optimum temperature. It also seals the leaks between the rotors and the housing and lubricates the bearings and gears. The airend consists of two counter-rotating intermeshed helical screws - the male and the female rotors - which are driven by electric motor. The air-oil mixture is trapped between the rotors of the airend and is progressively compressed.

After being compressed, the air-oil mixture enters with high velocity into the air-oil separator tank where it undergoes a unique 3 stage separation process which removes maximum oil content. This highly efficient 3 stage separation process uses the impact velocity of air-oil mixture along with centrifugal action, which makes the mixture very lean. The final stage of this separation consists of passing the lean mixture through the air-oil separator element which leaves the air with an oil content of < 1 ppm.

The oil separated and collected in this element is then returned to the airend through the oil return line. The air passes through a minimum pressure valve (MPV). It maintains a minimum differential pressure which is required for circulation of oil within the compressor unit. The compressed hot air is cooled in the after cooler and is

separated of any moisture content by the moisture separator. The cooled and moisture free compressed air is now discharged to the external receiver, ready to be used.

### 2.4.2 Oil circuit

The oil in the air-oil separation tank after being separated is fed into the airend. The oil either gets diverted to the oil cooler or oil filter or both depending upon the temperature. The thermal valve governs and controls the oil flow path. The oil before being injected into the airend is filtered. An orifice is provided in oil flow path towards the airend to control the oil flow. The whole oil circulation circuit in the compressor is operated solely by the differential pressure maintained by the minimum pressure valve (MPV) and doesn't require any additional pump.

### 2.4.3 Drive system

The airend transmission is powered by an electric induction motor through a coupling. When the compressor is turned ON, the motor is started in star mode and takes 6 to 9 seconds to change over to delta mode. During this period the intake valve remains closed and thus the motor starts without load. In delta mode, the motor speed stabilizes, the solenoid valve energizes after 10 seconds of change-over to reduce load on the motor, the blow down valve is closes, intake valve opens and the compressor starts loading. For compressors with variable frequency drive (VFD), speed of the motor gradually increases within 30 seconds (ramp-up time) while the intake valve remains in the closed position. This ensures very little starting load. Next, the intake valve opens and the system starts building up pressure. An adaptor ring connects the airend and the motor. It also helps in maintaining the coupling alignment. The coupling element acts as a safety interlock and it is the first one to fail when coupling elements become over loaded. This architecture saves the whole drive system from failure. Malfunctioning of the coupling

element will result in noise and vibration. Anti-vibration mountings reside below the air end and the motor. This configuration reduces the transmission of vibration from air end and motor to the structure, reducing noise and ensuring reliability of mounted parts on the structure.

**2.4.4 Control system**

**Load - Unload**

Depending on the demand for compressed air from the application at a particular time, the compressor needs to respond accordingly. The compressor, therefore operates in either loading or unloading mode to meet this requirement. The primary objective of these modes is to save energy and reduce wear and tear on the machine. The control system ensures a smooth start without overloading the motor. The compressor is started in star mode, during which most of the compressed air is vented to the atmosphere. This mechanism helps prevent overloading the motor. In delta mode the motor speed stabilizes, the solenoid valve energizes after 10 seconds of change-over to reduce load on the motor, the blow-down valve is closes, and the compressor starts loading.

When the receiver pressure reaches the maximum limit, a signal arrives the solenoid valve from the control system. Next, the inlet valve actuates and closes, and the compressor runs in unloading mode. If unloading mode continues for more than 5 minutes, i.e., compressed air is consumed and thus no decrease in pressure occurs, the system stops and switches to standby mode. If a drop in pressure occurs in the receiver, the compressor returns to loading mode automatically.

**Suction modulation**

When you operate a compressor without VFD, capacity control occurs via a pressure regulator (for selected models). When the consumption of air is less than the FAD of the compressor, the line pressure will start increasing. Whenever the line pressure goes up constantly beyond the set pressure, the pressure regulator bleeds the excess air to the atmosphere thereby reducing the amount of flow into the actuator. The actuator is spring loaded, which, in turn, closes the intake valve slightly and enables capacity control. Similarly when the consumption of air is more than the FAD, the line pressure starts decreasing and the actuator progressively opens the intake valve. This regulation is called intake modulation by throttling.

**VFD modulation**

VFD is an efficient way of controlling capacity as per demand. In a compressor with VFD the power of compressor varies proportionally with capacity reduction. The VFD tunes the frequency, thereby adjusting the speed based on the change in line pressure. The incoming flow will automatically reduce because of reduced speed of the motor. Conversely speed increases when line pressure goes down below working pressure.

**2.4.5 For retro-fitment of Standalone VFD with Compressor (C) version in field**

1. Change the bearings to insulated type for motors >=90kw at Non Drive End side of Motor
2. Turndown only upto 50% for conversion models (considering the motor speed) i.e. motor frequency range is 50 - 25 Hz for 50Hz variant and 60 - 30Hz for 60Hz variant. No pressure turndown is applicable
3. Run the compressor in the VFD operating range (50 to 25Hz) and skip the frequency in VFD controller (within +/- 1Hz) if abnormal noise / vibration is observed
4. Change the thermal element from 65°C to 75°C



S/NO	DESCRIPTION	QTY
17	PRE FILTER	1
16	CONTROLLER	1
15	VARIABLE FREQUENCY DRIVE (VFD)	1
14	MOISTURE SEPARATOR WITH ADV	1
13	SAFETY VALVE	1
12	AIR OIL SEPARATOR	1
11	DRIVE COUPLING	1
10	OIL AND AFTER COOLER ASSY	1
9	CONTROL PANEL	1
8	COOLER FAN	2
7	MINIMUM PRESSURE VALVE	1
6	INTAKE VALVE	1
5	AIR FILTER	1
4	OIL FILTER	1
3	AIR - OIL SEPARATOR TANK	1
2	AIR END	1
1	MOTOR	1

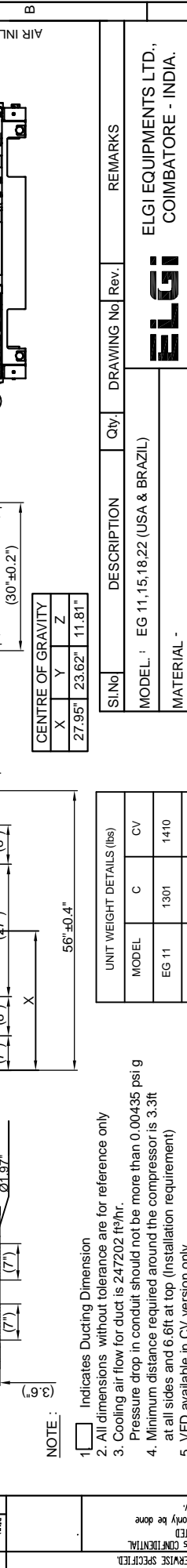
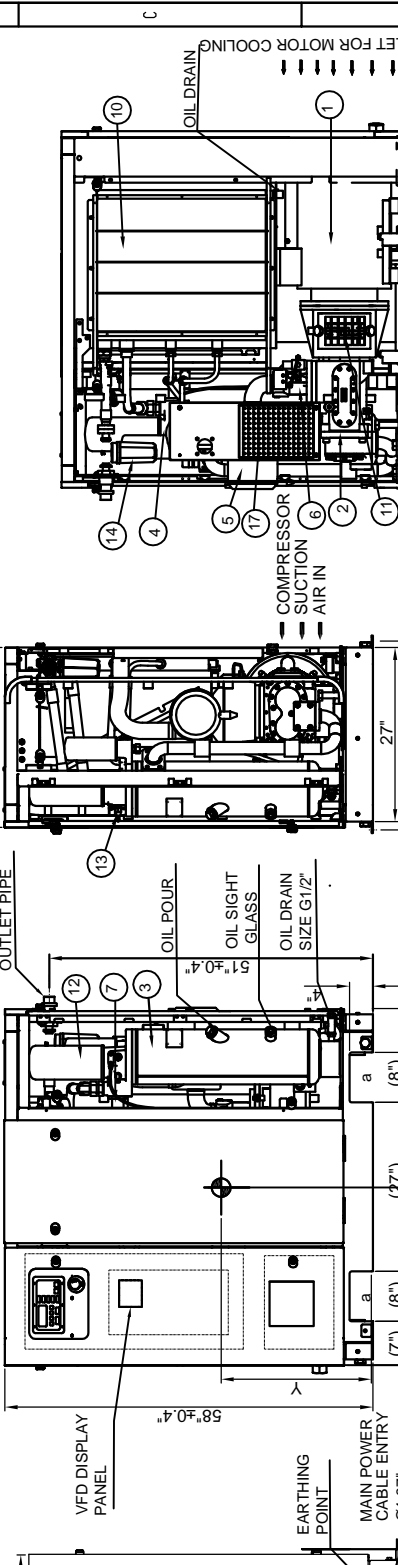
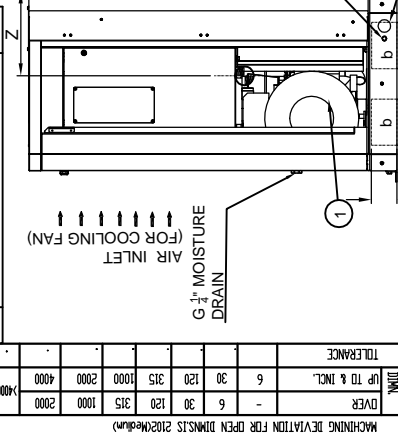
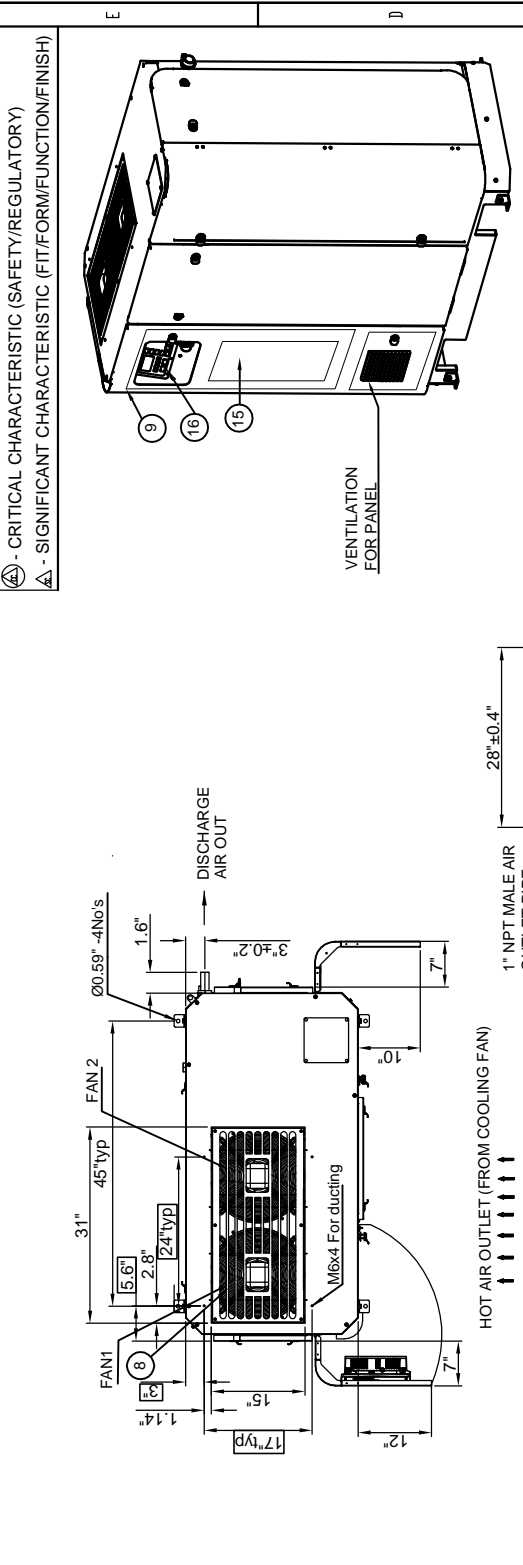

CENTRE OF GRAVITY

X	Y	Z
27.95"	23.62"	11.81"

SI.No	DESCRIPTION	Qty	DRAWING No	Rev.	REMARKS
MODEL :	EG 11,15,18,22 (USA & BRAZIL)				
MATERIAL :	-				

UNIT WEIGHT DETAILS (lbs)	MODEL	C	CV
	EG 11	1301	1410
	EG 15	1344.8	1521
	EG 18	1499	1565
	EG 22	1521	1576

- NOTE :
- Indicates Ducting Dimension
  - All dimensions without tolerance are for reference only
  - Cooling air flow for duct is 247202 ft<sup>3</sup>/hr.
  - Pressure drop in conduit should not be more than 0.00435 psi/g at all sides and 6.6ft at top (Installation requirement)
  - Minimum distance required around the compressor is 3.3ft (Installation requirement)
  - VFD available in CV version only
  - For EG 11 model fan qty 1 no mounted on Fan 2 position
  - For EG 15 to EG 22 models cooling fan qty 2 no's
  - a: mentioned place for fork lift access
  - 9: mentioned place for pallet truck access

**ELGI** ELGI EQUIPMENTS LTD.,  
COIMBATORE - INDIA.

**GA DRAWING-EG SERIES**  
C AND CV

SCALE: NTS

DATE: 31.01.17

CHECKED: SS

APPROVED: PMD

DRG.No: 015315578

DRG.SHEET: 1 OF 2

REVISION: R1011

REV. NO.	ECO.No.	DATE	DESCRIPTION	ALT. BY	CHKD. BY

SI.No	DESCRIPTION	Qty	DRAWING No	Rev.	REMARKS
MODEL :	EG 11,15,18,22 (USA & BRAZIL)				
MATERIAL :	-				
WEIGHT:	-				

ALL INFORMATION CONTAINED IN THIS DOCUMENT IS CONFIDENTIAL AND THE PROPERTY OF ELGI EQUIPMENTS LIMITED. REPRODUCTION OR TRANSMISSION IN ANY FORM WITHOUT THE WRITTEN PERMISSION OF THE COMPANY.

6 5 4 3 2 1

- CRITICAL CHARACTERISTIC (SAFETY/REGULATORY)  
- SIGNIFICANT CHARACTERISTIC (FIT/FORM/FUNCTION/FINISH)

P & I DRAWING

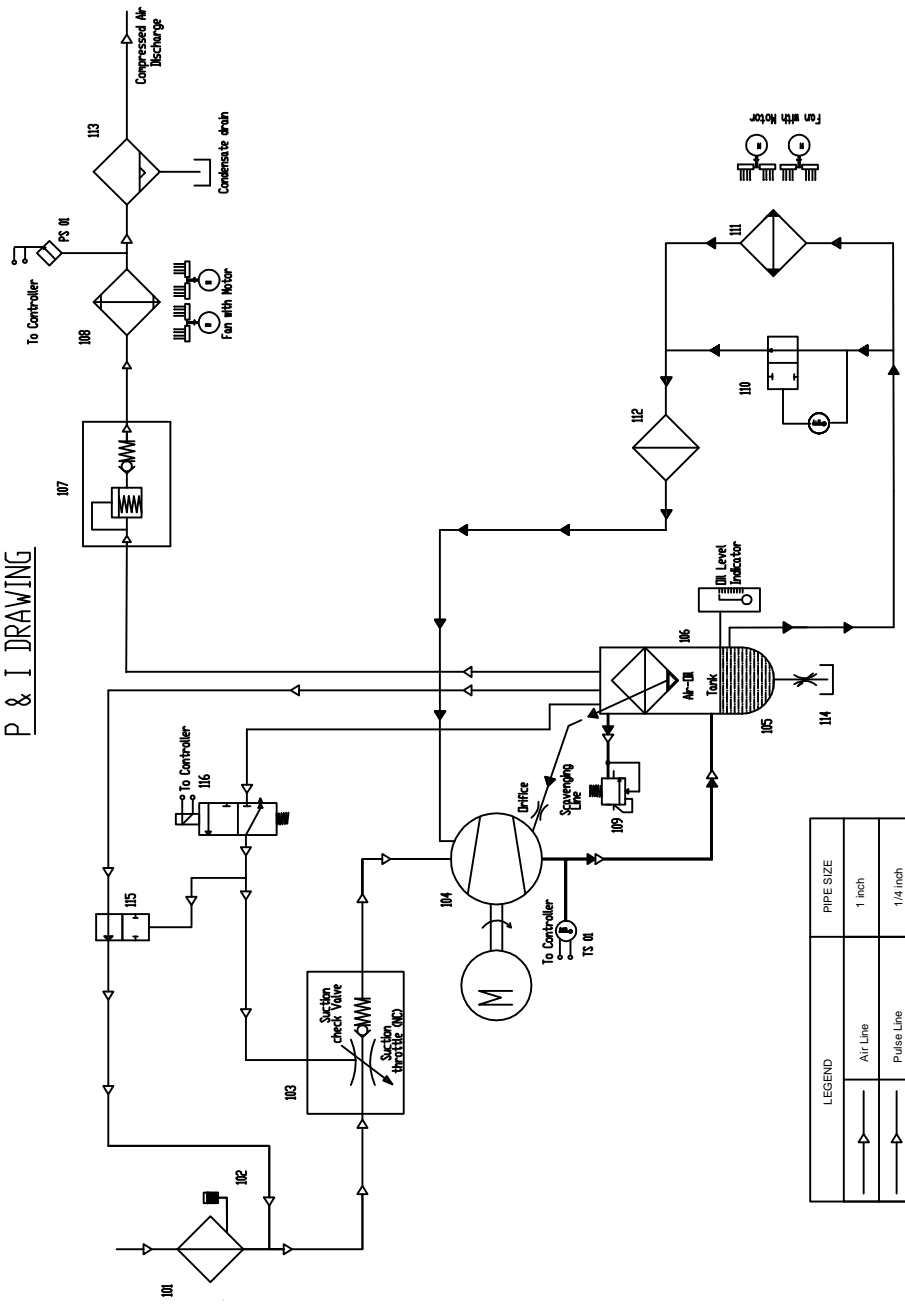

LEGEND

101		AIR FILTER
102		CHOKe INDICATOR
103		INTAKE VALVE (NC)
104		AIR END
105		AIR - OIL SEPARATOR TANK
106		AIR-OIL SEPARATOR
107		MINIMUM PRESSURE VALVE
108		AFTER COOLER
109		SAFETY VALVE
110		THERMAL VALVE
111		OIL FILTER
112		OIL LINE
113		OIL DRAIN VALVE
114		SOLENOID VALVE (NC)

LEGEND	PIPE SIZE
	1 inch
	1/4 inch
	3/4 inch
	2 inch
	-

INSTRUMENT TAG NO.	DESCRIPTION	LOCATION	RANGE
TS01	TEMPERATURE SENSOR	After Air end	0-150° C
PS01	PRESSURE SENSOR	After moisture separator	4 - 16 bar
116	SOLENOID VALVE (NC)	on intake valve	220 V AC - NC

S.No	DESCRIPTION	Qty.	DRAWING No	Rev.	REMARKS
MODEL : EG 11,15,18,22 (USA & BRAZIL)					
MATERIAL -					
WEIGHT:					
CAD	KIV	DATE	REF.DRG.No.	NEXT ASSY.	
CHECKED	SS	23.01.17	SCALE	DRG.No.	01 53 1557 8
APPROVED	PMD	23.01.17	NTS	DRG.SHEET	2 OF 2
CHKD. BY	ALT. BY	DESCRIPTION	DATE	ECO.No.	REVISION
					R 10 11

**ELGI** ELGI EQUIPMENTS LTD.,  
COIMBATORE - INDIA.

GA DRAWING-EG SERIES  
C AND CV

ALL DIMENSIONS ARE IN INCH UNLESS OTHERWISE SPECIFIED.  
ALL INFORMATION CONTAINED IN THIS DOCUMENT IS CONFIDENTIAL  
AND THE PROPERTY OF ELGI EQUIPMENTS LIMITED  
REPRODUCTION OF THESE IN ANY FORM SHOULD ONLY BE DONE  
WITH THE SPECIFIC PERMISSION OF THE COMPANY.

SURFACE FINISH SYMBOLS	MACHINING DEVIATION FOR OPEN DIMENSIONS 2020(±0.04mm)	
	OVER	TOLERANCE
▽	5	± 0.10
▽▽	30	± 0.12
▽▽▽	315	± 0.15
▽▽▽▽	1000	± 0.20
▽▽▽▽▽	2000	± 0.25
▽▽▽▽▽▽	4000	± 0.30
▽▽▽▽▽▽▽	8000	± 0.35
▽▽▽▽▽▽▽▽	16000	± 0.40
▽▽▽▽▽▽▽▽▽	32000	± 0.45
▽▽▽▽▽▽▽▽▽▽	64000	± 0.50

## 4.0 Technical data

### Standard, Standard + VFD

Model		-	EG 11				EG 15				EG 18				EG 22			
Working pressure		psi.g	100	125	150	175	100	125	150	175	100	125	150	175	100	125	150	175
FAD - Free air		cfm	70	62	55	49	91	84	77	69	116	107	91	80	140	132	112	95
Delivery		m <sup>3</sup> /min	1.98	1.76	1.56	1.39	2.58	2.38	2.18	1.95	3.28	3.03	2.58	2.27	3.96	3.74	3.17	2.69
Unloading pressure		psi.g	107	132	157	182	107	132	157	182	107	132	157	182	107	132	157	182
Nominal power supply conditions		-	208-230V / 460V (+/-10%), 60Hz(+/-5%),3phase															
Main motor rating		hp	15				20				25				30			
Type of motors (main drive & fan drive)		-	Squirrel Cage Induction-TEFC & Cooling Fan Integrated Motor															
Insulation and protection of main motor		-	Class F & IP55															
Frame size / mounting type		-	254T/L / B35				256T / B35				284T / B35				286T / B35			
Type of starter for main motor	STD	-	Automatic Star Delta															
	STD + VFD	-	Through Variable Frequency Drive															
Maximum fan motor rating per fan X no. of fans		hp	0.35 (208-230V) / 0.39 (460V) X 1 Fan				0.35 (208-230V) / 0.39 (460V) X 2 Fans											
Rated speed of fan motor		rpm	1490 (208V-230V) / 1560 (460V)															
Safety valve set pressure		psi.g	205															

<b>Contents</b>	<b>Page No.</b>
<b>5.1. Installation and commissioning</b>	<b>5.2</b>
5.1.1 Unpacking	5.2
5.1.2 Disposal of packing materials	5.2
5.1.3 Handling the compressor	5.2
5.1.4 Site requirements	5.2
5.1.4.1 Ventilation	5.3
5.1.5 Electricals	5.4
5.1.6 Air pipe dimensions	5.5
5.1.7 Receivers for compressed air systems	5.7
5.1.8 Possible mistakes	5.7
5.1.9 Commissioning procedure	5.7
5.1.10 Oil fill procedure	5.8
<b>5.2. Preservation for long idle storage</b>	<b>5.9</b>
5.2.1 Airend	5.9
5.2.2 Motor	5.9
5.2.3 Air-oil separator tank	5.9
5.2.4 Rubber hoses	5.9
<b>5.3. Operating instructions</b>	<b>5.10</b>
5.3.1 Initial start-up checks	5.10
5.3.2 Initial start-up	5.10
5.3.3 Pre-start checks	5.10
5.3.4 Starting	5.10
5.3.5 During running	5.10
5.3.6 Stopping	5.11
5.3.7 Changing the compressor settings	5.11

## 5.1 Installation and commissioning

Before the new EG series compressor is operated for the first time, it needs to be installed at your site according to ELGi's installation guidelines.

### 5.1.1 Unpacking

Unpack the compressor from the packing case by removing the nails. Unscrew the bolts, holding the compressor to the base of the crate.

Once the packing material is removed, check the contents against the packing list. The compressor is shipped with the following

- Key for doors
- Operation and maintenance manual
- Checklist of parts of the machine
- Electrical drawing

### 5.1.2 Disposal of packing material

The wood/cardboard used to make the shipping crates of the EG series compressors are biodegradable.

The polyethylene covers wrapped around the compressor and the polystyrene packing provided around the electrical panels are not recyclable. They must be disposed off in accordance with prevailing local environmental laws.

### 5.1.3 Handling

1. Lift compressors using either a forklift/pallet truck (Fig.2) or a crane (Fig.3).
2. When using a forklift, ensure padding is used in between the compressor and forklift (as shown in Fig.2) to prevent damage to the compressor's canopy.
3. When using a crane, please ensure stiff spreader bars are used (as shown in Fig.3) to prevent rope slings from damaging the compressor's canopy.
4. Do not drop the compressor.
5. Do not attempt to move the compressor by pushing or dragging it as this may cause jerky movements causing damage to the compressor.

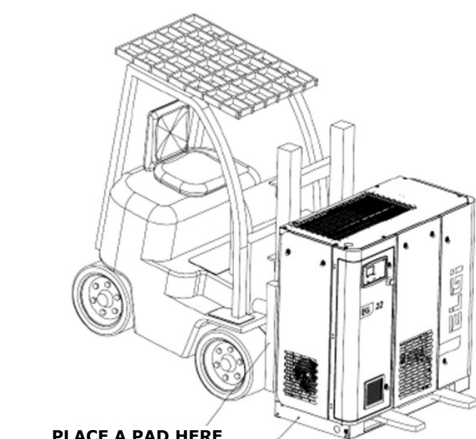

Figure 2. Lifting using forklift

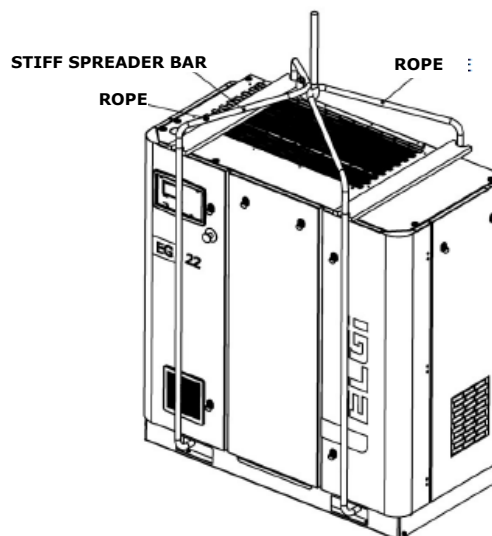

Figure 3. Lifting using crane

#### NOTE

##### Removal of transit brackets:

Once you have placed the compressor in its final position, remove the red painted transit brackets and store for future use.

##### Locations:

- Bracket in between the base and airend support
- Bracket in between the base and motor
- Bracket in between the shroud and control panel box

### 5.1.4 Site requirements

- Install the air compressor in a clean, dry, cool and dust free room as extreme temperatures (hot or cold), moisture, air borne contaminants can significantly affect compressor performance, durability and compressed air quality.
- Be aware the entrance to the compressor room should be high enough and wide enough to carry the compressor in and out.
- Leave a minimum of 1m (3.28ft) space around the compressor for safe and proper inspection, cleaning, and maintenance activities.
- Leave minimum of 2m (6.56ft) space above the compressor for hot air to flow away from the compressor.
- Ensure the compressor is protected against direct sunlight and rain.
- Avoid exposing the compressor to excessive moisture (from rain, dryer vent, etc.) as moisture can affect airend lubrication, promote rust formation on the compressor and lead to electrical problems of the motor.
- Neither install the machine in a location where flame is used nor place any inflammable objects near the compressor.

- Ensure the room temperature is within 50°C (122°F) as high ambient temperatures can reduce oil life due to higher discharge oil temperature (DOT). It also results in high approach temperatures affecting cooling and condensation efficiency in the after-cooler and in air treatment equipment like air dryers.
- Ensure the hot medium of other utility equipments like genset/dryer/ boilers, etc., hot medium not sucked by compressor inlet or that in any way room temperature does not rise to prevent high discharge oil temperature.
- Ensure the ambient temperature does not drop below 0°C (32°F). Provide air supply openings and adjustable louvers to ensure that the minimum temperature does not drop down below 0°C (32°F).
- Ensure unevenness of the surface is within 6mm (0.25").

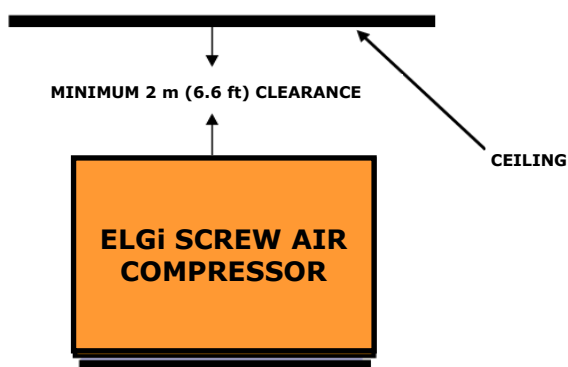

**Figure 4. Vertical clearance around the compressor**

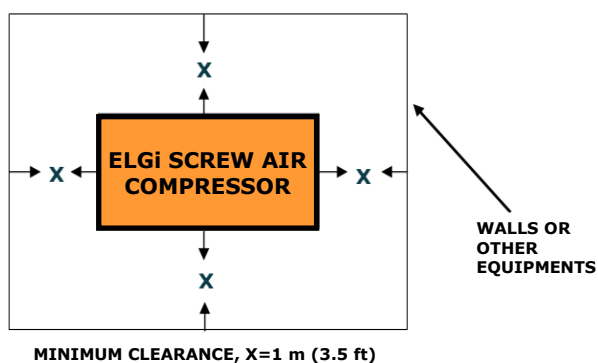

**Figure 5. Horizontal clearance around the compressor**

- If the floor is splashed frequently with water while cleaning, then place your compressor on a raised concrete plinth 100 to 150 mm (4 to 6 inches) high.
- Ensure the compressor base makes 100% contact directly with the floor.
- Know that an industrial floor with level surface capable of supporting the weight if the compressor is sufficient

for installing your compressor. No special foundation or anchoring is necessary for rotary screw compressors.

- Do not store toxic, volatile, or corrosive agents near the compressor.
- Isolate the compressor from corrosive agents like ammonia, chlorine, salt spray, and other chemicals as these may erode the internal components and also contaminate the oil and filters.
- Do not allow hot air from additional equipment to blow towards the compressor.
- If you operate in high dust applications like rice mills, cement, flour mills, etc., it would be necessary to clean and replace the filters more often.
- Good practice is to have overhead lifting in the compressor room to facilitate any major overhaul. If an overhead hoist is not available, you should be able to use a mobile crane or forklift truck in your compressor room at a minimum.

#### 5.1.4.1 Ventilation

- A part of electric energy to your compressor motor is converted into heat and this heat must be removed from the compressor room by suitable ventilation.
- The ventilation requirements of the compressor are listed in Table 1.
- The ventilation requirements could be achieved by the following methods.
- Natural ventilation is sufficient if the temperature rise in the compressor room (measured by a thermometer near the air inlet pre-filter) is within 5°C (9°F) when compared with outside temperature
- Forced ventilation with an exhaust fan is necessary if the temperature rise inside the room (measured by a thermometer near the air inlet pre-filter mesh) is rises above 5°C (9°F) .
- Ventilation with ducts: Ensure hot air exhaust from the compressor is diverted through the ducts when installed in an enclosed area. (contact ELGi for ducting requirements)
- Provide openings on walls/partitions close to the air suction side of the compressor.
- Provide exhaust openings close to the ceiling for hot air exit.
- If more than four compressors are installed in a room, good practice is to provide ducting arrangements. This will avoid hot air recirculation.
- Be aware hot air recirculation in the enclosed area will affect the compressor performance.
- Ensure the air velocity in the supply and exhaust ducts does not exceed 4 m/s (13 ft/s).
- Know air velocity is ascertained during commissioning



using an anemometer.

- Do not connect cool air inlet ducts directly to the compressor inlet side.

Model	Minimum ventilation requirement (ft <sup>3</sup> /h )	Minimum ventilation requirement (m <sup>3</sup> /h)
EG 11	94,537	2,677
EG 15	128,086	3,627
EG 18	157,185	4,451
EG 22	204,154	5,781
EG 30	242,576	6,869
EG 37	299,185	8,472
EG 45	363,847	10,303
EG 55	464,246	13,146
EG 75	631,708	17,888
EG 90	705,481	19,977
EG 110	864,821	24,489
EG 132	1,033,801	29,274
EG 160	1,273,482	36,061
EG 200	1,718,976	48, 676
EG 250	1,718,976	48, 676
EG 90-P	708,765	20,070
EG 110-P	1,218,356	34,500
EG 132-P	1,218,356	34,500
EG 160-P	1,218,356	34,500

**Table 1. Global series – Ventilation requirements**

- To eliminate transmission of vibrations, provide a soft bellows connector between the duct and the compressor.
- Contact ELGi in case you need to provide a duct connection or filter fitment on the compressor.

### 5.1.5 Electricals

Model	Motor power		Back up fuse		Incoming Cable size		Incoming Cable size		Earth cable	Gland Size
	kW	H.P	208 - 230V	460V	Cu Sq.mm	Al Sq.mm	Cu Sq.mm	Al Sq.mm	Size	Dia
EG 11	11	15	100A	63A	4 X 10	4 X 16	4 X 4	4 X 6	2.5 Gauge	25 mm
EG 15	15	20	100A	63A	4 X 16	4 X 25	4 X 6	4 X 10	2.5 Gauge	25 mm
EG 18	18	25	125A	63A	4 X 25	4 X 35	4 X 6	4 X 10	2.5 Gauge	25 mm
EG 22	22	30	160A	63A	4 X 35	4 X 50	4 X 10	4 X 16	4 Gauge	28 mm
EG 30	30	40	200A	100A	4 X 50	4 X 70	4 X 16	3 1/2 X 25	4 Gauge	32 mm
EG 37	37	50	250A	125A	4 X 70	4 X 95	3 1/2 X 25	3 1/2 X 35	6 Gauge	35 mm
EG 45	45	60		125A			3 1/2 X 35	3 1/2 X 50	6 Gauge	35 mm
EG 55	55	75		160A			3 1/2 X 35	3 1/2 X 50	6 Gauge	35 mm
EG 75	75	101		250A			3 1/2 X 70	3 1/2 X 95	8 Gauge	50 mm
EG 90	90	121		250A			3 1/2 X 70	3 1/2 X 95	8 Gauge	50 mm
EG 110	110	147		315A			3 1/2 X 95	3 1/2 X 120	25 x 3 cu flat	1.75 inch
EG 160	160	214		400A			3 1/2 X 150	3 1/2 X 185	35 x 3 cu flat	2.25 inch

**Table 2. Global series – Electrical requirements**

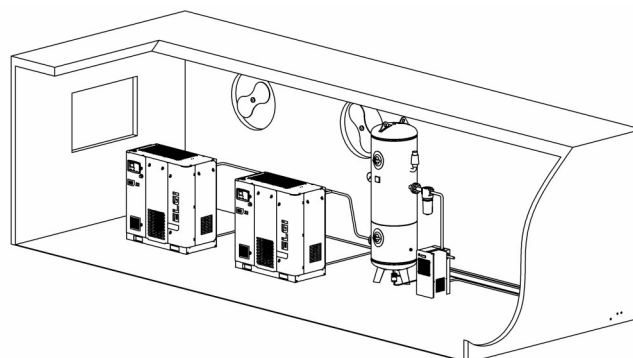

**Figure 6. Forced ventilation with exhaust fan**

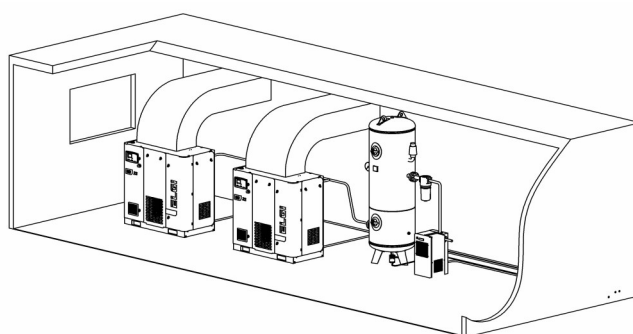
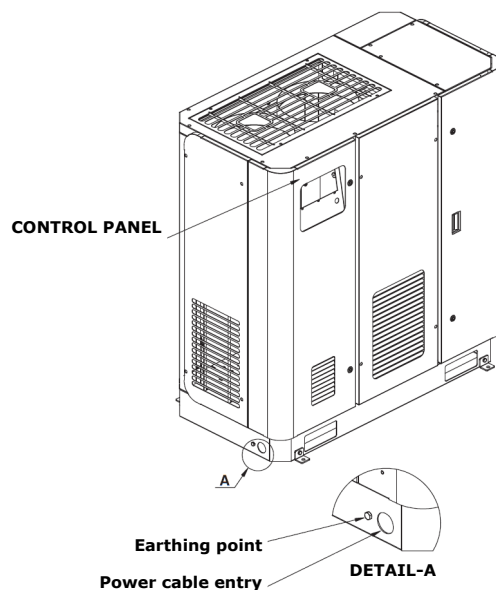

**Figure 7. Ventilation with ducts**

**⚠ WARNING**

Ensure that only authorized service technicians perform electrical work. Study the electrical circuit diagram before starting work.

1. Supply power to the compressor through a dedicated switch disconnected fuse (SDF) unit of a suitable rating mounted within 5 m (16.4ft) of the compressor. (This architecture lets you isolate the compressor).
2. Use HRC (high rupturing current) fuse instead of an MCCB (moulded case circuit breaker) to avoid possible contactor and motor failure.
3. Refer to Table 2 for fuse and cable specifications for 208 -230/380/440/460 V, 60Hz, 3-Ph power supplies.
4. Do not use an MCB (miniature circuit breaker) because the selection of contactors is based on Type-2 co-ordination.
5. Connect the earthing line to the point provided on the base frame at the side of the compressor and motor.



**Figure 8. Earthing line of compressor**

### 5.1.6 Air pipe dimensions

Volume Flow FAD		NPS Pipe size/ Inside diameter (mm)									
		1/2 15.80		3/4 20.93		1 26.65		1 1/4 35.05		1 1/2 40.89	
(m <sup>3</sup> /min)	(cfm)	(bar)	(psi)	(bar)	(psi)	(bar)	(psi)	(bar)	(psi)	(bar)	(psi)
0.1	4	0.02	0.22								
0.2	7	0.06	0.80	0.01	0.20						
0.3	11	0.12	1.69	0.03	0.41	0.01	0.12				
0.4	14	0.20	2.88	0.05	0.71	0.01	0.21				
0.5	18	0.30	4.35	0.07	1.07	0.01	0.32	0.01	0.08		
0.6	21	0.43	6.09	0.10	1.49	0.03	0.45	0.01	0.11		
0.7	25	0.57	8.10	0.14	1.99	0.04	0.59	0.01	0.15		
0.8	28	0.73	10.38	0.18	2.54	0.05	0.76	0.01	0.19	0.01	0.09
0.9	32	0.90	12.90	0.22	3.16	0.07	0.95	0.02	0.24	0.01	0.11
1.0	35	1.10	15.68	0.27	3.84	0.08	1.15	0.02	0.29	0.01	0.13
1.2	42			0.38	5.38	0.11	1.61	0.03	0.41	0.01	0.19
1.4	49			0.50	7.16	0.15	2.14	0.04	0.54	0.02	0.25
1.6	56			0.64	9.16	0.19	2.74	0.05	0.70	0.02	0.32
1.8	64			0.80	11.40	0.24	3.41	0.06	0.87	0.03	0.40
2.0	71			0.97	13.85	0.29	4.14	0.07	1.05	0.03	0.49
2.2	78			1.16	16.52	0.35	4.94	0.09	1.25	0.04	0.58
2.4	85			1.36	19.40	0.41	5.80	0.10	1.47	0.05	0.68
2.6	92					0.47	6.73	0.12	1.71	0.06	0.79
2.8	99					0.54	7.72	0.14	1.96	0.06	0.91
3.0	106					0.61	8.77	0.16	2.23	0.07	1.03
3.5	124					0.82	11.66	0.21	2.96	0.10	1.37
4.0	141					1.05	14.93	0.27	3.79	0.12	1.75
4.5	159					1.30	18.57	0.33	4.71	0.15	2.18
5.0	177							0.40	5.73	0.19	2.65
5.5	194							0.48	6.83	0.22	3.16
6.0	212							0.56	8.02	0.26	3.71
6.5	229							0.65	9.30	0.30	4.30
7.0	247							0.75	10.67	0.35	4.94
7.5	265							0.85	12.12	0.39	5.61
8.0	282							0.96	13.66	0.44	6.32
8.5	300							1.07	15.28	0.50	7.07
9.0	318							1.19	16.99	0.55	7.86
9.5	335							1.32	18.477	0.61	8.69
10.0	353							1.45	20.64	0.67	9.55
15.0	530									1.42	20.22

Volume Flow FAD		NPS Pipe size/ Inside diameter (mm)									
		1 1/2		2		2 1/2		3		4	
		40.89		52.50		62.71		77.93		102.26	
(m <sup>3</sup> /min)	(cfm)	(bar)	(psi)	(bar)	(psi)	(bar)	(psi)	(bar)	(psi)	(bar)	(psi)
0.8	28	0.01	0.09								
0.9	32	0.01	0.11								
1.0	35	0.01	0.13								
1.2	42	0.01	0.19								
1.4	49	0.02	0.25	0.01	0.07						
1.6	56	0.02	0.32	0.01	0.09						
1.8	64	0.03	0.40	0.01	0.11						
2.0	71	0.03	0.49	0.01	0.14						
2.2	78	0.04	0.58	0.01	0.17						
2.4	85	0.05	0.68	0.01	0.20	0.01	0.08				
2.6	92	0.06	0.79	0.02	0.23	0.01	0.09				
2.8	99	0.06	0.91	0.02	0.26	0.01	0.11				
3.0	106	0.07	1.03	0.02	0.30	0.01	0.12				
3.5	124	0.10	1.37	0.03	0.39	0.01	0.16				
4.0	141	0.12	1.75	0.04	0.50	0.01	0.21				
4.5	159	0.15	2.18	0.04	0.63	0.02	0.26	0.01	0.09		
5.0	177	0.19	2.65	0.05	0.76	0.02	0.31	0.01	0.11		
5.5	194	0.22	3.16	0.06	0.91	0.03	0.37	0.01	0.13		
6.0	212	0.26	3.71	0.07	1.06	0.03	0.44	0.01	0.15		
6.5	229	0.30	4.30	0.09	1.23	0.04	0.51	0.01	0.17		
7.0	247	0.35	4.94	0.10	1.42	0.04	0.58	0.01	0.20		
7.5	265	0.39	5.61	0.11	1.61	0.05	0.66	0.02	0.22		
8.0	282	0.44	6.32	0.13	1.81	0.05	0.75	0.02	0.25		
8.5	300	0.50	7.07	0.14	2.03	0.06	0.83	0.02	0.28	0.01	0.07
9.0	318	0.55	7.86	0.16	2.25	0.06	0.93	0.02	0.31	0.01	0.08
9.5	335	0.61	8.69	0.17	2.49	0.07	1.02	0.02	0.35	0.01	0.09
10.0	353	0.67	9.55	0.19	2.74	0.08	1.13	0.03	0.38	0.01	0.10
15.0	530	1.42	20.22	0.41	5.80	0.17	2.38	0.06	0.80	0.01	0.21
20.0	706			0.69	9.87	0.28	4.06	0.10	1.37	0.02	0.35
25.0	883			1.05	14.92	0.43	6.13	0.15	2.07	0.04	0.53
30.0	1059			1.46	20.90	0.60	8.59	0.20	2.90	0.05	0.75
35.0	1236					0.80	11.43	0.27	3.86	0.07	0.99
40.0	1412					1.03	14.63	0.35	4.94	0.09	1.27
45.0	1589					1.28	18.20	0.43	6.14	0.11	1.58
50.0	1765							0.52	7.46	0.13	1.92
55.0	1942							0.62	8.90	0.16	2.29
60.0	2118							0.73	10.46	0.19	2.69
65.0	2295							0.85	12.13	0.22	3.12
70.0	2471							0.97	13.91	0.25	3.57
75.0	2648							1.11	15.80	0.28	4.06
80.0	2824							1.25	17.81	0.32	4.58
85.0	3001							1.40	19.92	0.36	5.12
90.0	3177									0.40	5.69
95.0	3354									0.44	6.29
100.0	3530									0.48	6.92
150.0	5295									1.03	14.64

**Table 3. Global series – Air pipeline dimensions**

**NOTE**

The above table shows the pressure drops in 100m length schedule 40 steel pipe at 7 bar (abs)

1. Use the pipe sizes (as in Table 3) for the delivery pipe that connects to ball valve of the compressor.

2. In case the main delivery pipe is more than 100 m (330 feet) long, use a pipe diameter that is one size bigger than shown in the table.

## 5.1.7 Receivers for compressed air systems

Receiver applications		Compressed capacity			
Volume		On/Off control		Modulation control	
m <sup>3</sup>	ft <sup>3</sup>	m <sup>3</sup> /min	cfm	m <sup>3</sup> /min	cfm
0.3	10.59	Up to 1.13	Up to 40	Up to 1.7	Up to 60
0.5	17.66	1.14 - 2.4	41 - 85	1.7 - 3.4	61 - 120
1.0	35.32	2.4 - 4.0	86 - 140	3.4 - 6.7	121 - 235
1.5	52.97	4.0 - 6.4	141 - 225	6.7 - 10.0	236 - 355
2.0	70.63	6.4 - 8.8	226 - 310	10.0 - 13.0	356 - 470
3.0	106.0	8.8 - 12.6	311 - 445	13.0 - 20.1	471 - 710
4.0	141.3	12.6 - 16.1	446 - 570	20.1 - 26.7	711 - 945
5.0	176.6	16.1 - 19.8	571 - 700	26.7 - 33.4	946 - 1180
6.0	211.9	19.8 - 24.0	701 - 850	33.4 - 40.0	1181 - 1415
7.0	247.2	24.0 - 28.0	851 - 990	40.0 - 46.7	1416 - 1650
8.0	282.5	28.0 - 32.0	990 - 1130	46.7 - 53.3	1651 - 1885

**Table 4. Global series—Receivers specifications**

### 5.1.8 Possible mistakes

1. The compressor is installed on the wooden pallet of the packing case.
2. The compressor base is not making 100% contact with the floor.
3. The compressor is mounted on anti-vibration mounts.
4. The isolator is more than 5m (16.40ft) away from the compressor.

### 5.1.9 Commissioning procedure

1. Please make preparations according to the installation section as given, before the compressor is commissioned.
2. Ensure that the location meets the requirements of accessibility, ventilation and safety.
3. Provide electrical power as recommended in the installation section.
4. Select air pipe lines and receivers for your system according to the tables provided in the installation section.

### Checkpoints before commissioning

Replace the parts in compressor if it had been in storage for more than one year.

1. Air filter
2. Oil filter
3. Air oil separator (check and replace)
4. Oil
  - a. Check for any external / internal damages of the package.
  - b. Monger the main motor and fan motor should be mongered to find the winding insulation conditions if the compressor is not commissioned for more than 1 year

- c. Re-grease the main motor if the compressor is not commissioned for more than 1- ½ years (18 months)
- d. Replace the AVMs if you detect any abnormal squeezing or damage in the rubber part.
- e. Check whether all the screws in the control panel are in place and tightened properly.
- f. Check the oil cooler and after-cooler for any external fin blockage and clear the blockage if necessary
- g. Ensure that all the transit brackets are removed.

### During commissioning

The servicing technician performs a series of checks on the machine and on the systems to which it connects, to ensure that it is in a condition to function safely and as recommended. The servicing technician will then explain to the operate and maintain the equipment. This procedure is referred to as the commissioning process.

The commissioning of the compressor ensures that it is installed safely.

The general operating conditions of the equipment including the cleanliness of the atmosphere, the temperature and the ventilation are checked. Technical details relating to your system such as particulars of your electrical installation are noted. The operator of the compressor is familiarized with all aspects of both its normal running and dealing with unusual situations.

Upon completion of the commissioning process, the technician will fill in the document known as the commissioning report and the warranty card provided in this manual.

During commissioning any modification suggested by the technician should be performed before the compressor is ready for regular use. Else, warranty becomes void. In case of change of operator other than the person trained, the new operator should be trained before he is dedicated

for operating the compressor.

### 5.1.10 Oil fill procedure

#### Initial oil fill procedure

Check whether your compressor comes with oil filled. This can be checked through the oil sight glass on the air oil separator. If not, follow the oil filling procedure given below.

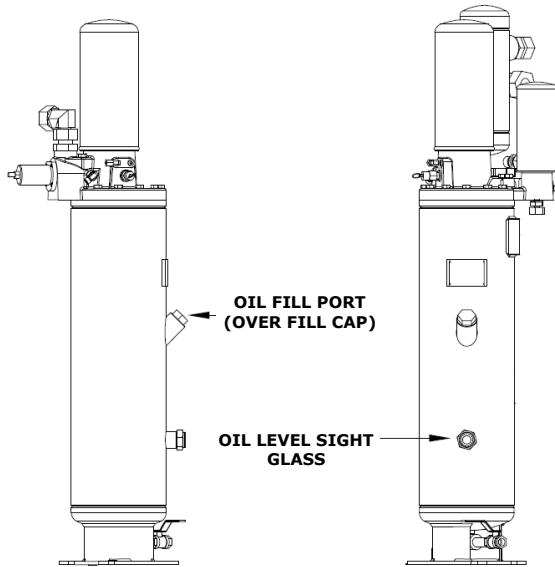

**Figure 9. Oil filling and oil sight glass location on air oil separator tank**

#### Oil level check

- The oil level should be half of the oil sight glass after fumes settle down following shutdown.
- Ensure that the oil level sight glass and eye vision are parallel while checking the oil level to avoid parallax error.

Sl. No.	Model	Volume of oil required (gallons)
1	EG 11, 15	2.9
2	EG 18, 22	3.7

**NOTE**

Refill oil in the tank if the level falls below the minimum level

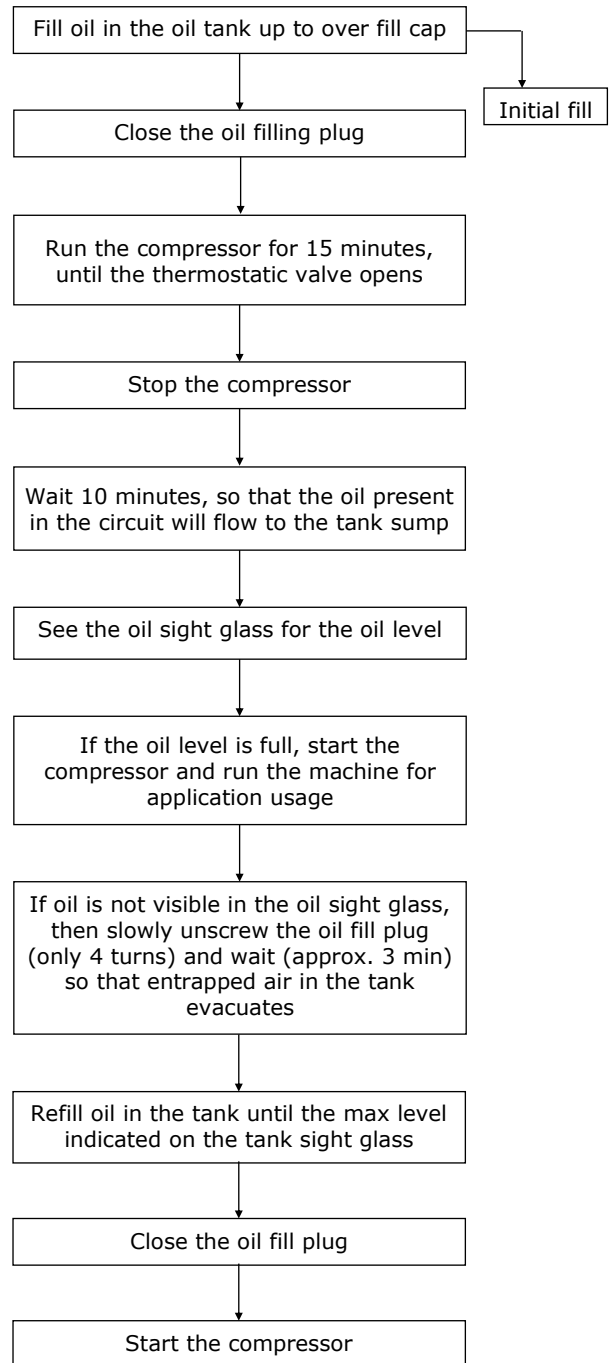

## 5.2 Preservation for long idle storage

If your compressor is going to remain unused for six months or longer, special measures must be undertaken to ensure the protection of the following components

- Airend
- Motors
- Air-oil separator tank
- Rubber hoses

### 5.2.1 Airend

To prepare the airend for 6-month storage:

- Remove the airend discharge hose/pipe coupling.
- Rotate the drive coupling three times so that the oil present inside the airend comes out through the discharge port.
- Block the discharge port completely.
- Remove the inlet rubber duct connected to the intake valve of the air filter assembly.
- Turn the intake valve flap and pour rust preventive oil (use Castrol DWX 32 or an equivalent grade) into the airend through the intake valve.
- Rotate the coupling five times by hand so that the rust preventive oil spreads all over the bearings, seals and other parts of the airend.
- Drain the rust-preventive oil by opening the discharge port plug fully.
- Refit the hose/pipe coupling on the discharge port.
- Take care to ensure that all the openings are plugged always to avoid dust entry.
- Rotate the compressor shaft once in 7 days and ensure free rotation.
- Repeat the procedure every six months.
- For more details contact ELGi office or distributor network.

### 5.2.2 Motor

To prepare the motor for 1-year storage:

- Check the insulation of the motor winding.
- Remove any moisture in the motor.
- Check junction box terminals for tightness of the wires.
- Apply grease on the motor bearings.

### 5.2.3 Air-oil separator tank

To prepare the air-oil separator for 2-year storage:

- Drain the oil from the separator tank.
- Remove the entire tank from the compressor after disconnecting it from all hoses, the tank top plate, the minimum pressure valve outlet line, and control pulse lines and control switches.
- Clean the tank using ELGi compressor clean flushing oil.

- Check the air-oil separator tank.
- Replace the oil filter element similarly.
- Flush the tank, airend with compressor oil and replace the separator element before using the compressor again.

### 5.2.4 Rubber Hoses

Test Recommendations for	
Age	Recommendations
Up to 3	Use without further testing
3 to 5 years	Use after representative samples are
5 to 8 years	Use after representative samples are subjected to proof, impulse, and burst pressure tests and cold bend and
Over 8 years	Scrap



### WARNING

Please adhere to the safety instructions provided at the section 2.3.2 : Precautions during operations

#### 5.3.1 Initial start-up checks

- Check whether the oil level in the tank is up to the specified level. If not, top up oil as per the oil fill procedure given in the maintenance section.
- Open all doors and visually check the compressor for abnormality. Make sure all connections are tight.
- Open the electrical panel door of the compressor and check that the three phases and earth cables are connected securely. (L1, L2, L3, and PE wires)
- Check the necessary earthing line in the panel/ compressor base.
- Ensure that all condensate drains are connected properly.
- For water cooled compressors, ensure that the water inlet and outlet valves are opened. Also make sure that the inlet and outlet water drain valves are closed.
- For water cooled compressors, ensure that the water quality is maintained as specified by ELGi.

#### 5.3.2 Initial start-up

Open the air outlet ball valve, turn on power, and press the start button (Green). Check whether the main motor turns clockwise (when viewed from the main motor fan side of the compressor). The correct direction of rotation is also shown on the motor. Ensure correct direction of rotation. If not, stop the compressor by pressing the stop button (Red) on the control panel. Open the isolating switch and reverse the appropriate lines.

### WARNING

Running the compressor in the wrong direction for more than 5 seconds will damage compressor parts or even cause total damage.

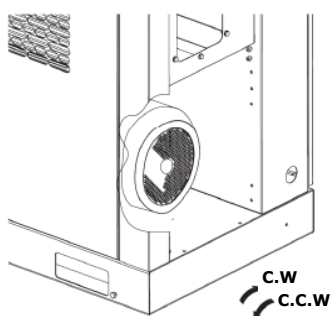

#### Gear models

- EG 11 - All pressures
- EG 15 - All pressures
- EG 18 - 150, 175
- EG 22 - 175

#### 5.3.3 Daily start checks

Before using the compressor everyday, you must prepare it by performing these tasks:

- Check whether the oil level in the tank is up to the specified level. If not, top up oil as per the oil fill procedure given in the maintenance section.
- Open all doors and visually check the compressor for abnormality. Make sure all connections are tight.
- Refer section 6.1.1 for how to perform daily maintenance activities.

#### 5.3.4 Starting

To prepare to start the system, perform these tasks:

- Open the air discharge valve.
- Turn on power.
- If all the inputs from contact switches, pressure and temperature transducers are normal, the display will indicate "READY".
- Press the "START" (green) button on the controller.
- Machines with an automatic star-delta starter will have 6 seconds changeover time from star to delta and another 10-seconds delta-to-run delay.

#### 5.3.5 During running

To ensure seamless running:

- Monitor the controller display and control panel indicators regularly when the compressor is running.
- **Graphic warning display:** This gives graphically the location of fault.

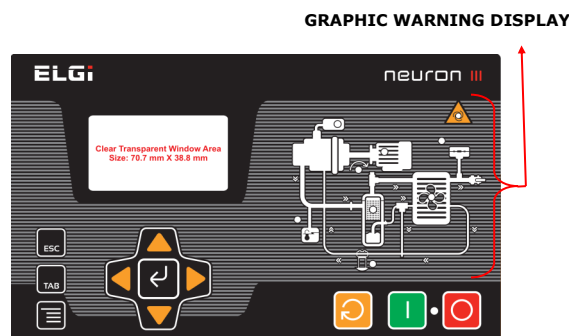

Figure 10. Human machine interface

- **Discharge temperature sensor & warning:** It is fixed on the air-oil discharge pipe. It senses the temperature of the discharge air-oil mixture. The compressor will shutdown automatically and the warning light on the controller will glow when the discharge temperature exceeds the preset value of  $110 \pm 5^\circ\text{C}$  ( $230 \pm 9^\circ\text{F}$ ).
- **Separator element warning:** Indicates that the separator element needs to be replaced. The compressor will not shutdown automatically in this situation.

- **Oil filter warning:** Indicates that the oil filter element needs to be replaced. The compressor will not shutdown automatically in this situation.
- **High discharge temperature warning:** The compressor will shutdown automatically and the warning light on the controller will glow when the discharge temperature exceeds the preset value of  $110 \pm 5^{\circ}\text{C}$  ( $230 \pm 9^{\circ}\text{F}$ ).
- **Main motor overload trip:** The compressor will shutdown when the main motor is overloaded and the corresponding warning light will glow.
- **Fan motor overload trip:** The fan motor has internal thermal overload protection, which safeguards the fan motor. If the fan motor trips discharge oil temperature will be high and the compressor will trip .
- **Reset button:** This button must be pressed before restarting the compressor after it has shutdown with a warning. The machine must be restarted only after taking necessary remedial measures.
- **Safety valve:** This valve relieves the pressure in the air -oil separator tank when it exceeds the set pressure. Refer "**Technical data**".
- **Reverse direction switch:** If the motor rotates in the wrong direction, the reverse direction switch detects and, in turn, trips off the compressor.
- After reaching the maximum cutoff pressure the pressure sensor senses the pressure and cuts off the solenoid electrical supply.

Model	Type	Cutout pressure bar (psi)
EG 11 - EG 45	Standard, Standard +VFD	Working pressure + 0.5 (7)
EG 55 - EG 160	Standard	Working pressure + 1 (15)
	Standard +VFD	Working pressure + 0.5 (7)

### 5.3.6 Stopping

- Press the stop (Red) button in the controller. The compressor will come to a halt within 10 seconds.
- In case of emergency, to stop the compressor, use the emergency stop switch. Correct the fault, rotate counterclockwise and unlock the emergency switch. Then press the reset button before the next start.
- Do not use the emergency stop switch for normal stopping.
- Isolate power to the compressor.
- Close the air discharge valve.
- For water cooled models, close the water inlet valve.
- If there is any possibility of freezing exists, drain the cooling system completely.

### 5.3.7 Changing the compressor settings

Change the compressor settings using the tactile keypad and LCD panel on the controller. (Refer to Neuron manual to learn more about the control panel and how to interpret of the message.)

Refer the VFD setting procedure manual for VFD operations.

#### **WARNING**

- *Isolate power supply before the discharge ball valve closes.*
- *Do not use the emergency stop switch for normal stopping*





<b>Contents</b>	<b>Page No.</b>
<b>6.1. Maintenance</b>	<b>6.2</b>
6.1.1 Maintenance intervals	6.2
6.1.2 Maintenance of individual components & systems	6.3
6.1.2.1 Pre filter	6.3
6.1.2.2 Air filter	6.3
6.1.2.3 Air oil Separator	6.4
6.1.2.4 Oil top up and oil changeover	6.5
6.1.2.5 Oil filter	6.5
6.1.2.6 Intake valve	6.6
6.1.2.7 Blow down valve	6.8
6.1.2.8 Minimum pressure valve	6.8
6.1.2.19 Thermal valve	6.9
6.1.2.10 Electrical motor greasing	6.9
6.1.2.11 After and oil coolers	6.9
6.1.2.12 Cooler prefilter accessory	6.9
6.1.2.13 Drive coupling	6.10
6.1.2.14 Moisture separator and auto drain valve	6.10
6.1.3 Use only genuine spare parts	6.12
<b>6.2. Troubleshooting</b>	<b>6.13</b>
<b>6.3. Decommissioning, dismantling &amp; putting out of service</b>	<b>6.18</b>
6.3.1 Waste disposal	6.18
6.3.2 Dismantling the compressor	6.18
6.3.3 Decommissioning the compressor	6.18
6.3.4 Disposal of consumables and replaced parts	6.18
<b>6.4. ELGi services</b>	<b>6.19</b>
6.4.1 ELGi customer care system (ECCS)	6.19
6.4.2 ELGi genuine spare parts	6.19
6.4.3 Air audit	6.19
<b>6.5. Appendix</b>	<b>6.21</b>
6.5.1 Conversion tables	6.21
6.5.2 Torque values	6.22
6.5.3 Service log book	6.23
<b>6.6. Disclaimers</b>	<b>6.24</b>

## 6.1.1 Maintenance intervals

Frequency	Part	Remarks
Daily	Oil level	Check
	MOS condensate	Check
	Warning / alarms	Check
	Condensate in AOS tank	Check
Weekly	Pre filter ( air intake, cooler, control panel)	Clean
	Air filter element	Clean *
2000 hours	Oil & after coolers - air cooled (External)	Check & Clean
	Oil filter	Replace
	Oil	Sampling **
	50 Hz motor - 2 pole grease	Replace
4000 hours or every year #	Pre filter ( air intake, cooler, control panel)	Replace
	Air filter element	Replace
	Oil – Air lube XD / Air lube FG	Replace
	Air-oil separator element – Air lube XD / Air lube FG	Replace
	50 Hz motor ( 4 pole ) grease	Replace
	60 Hz motor ( > 25HP ) grease	Replace
	Electrical connections	Check
	Return line sight glass / orifice / NRV	Check & Clean
	Return line strainer	Check & Clean
8000 hours or every 2 years #	Air-oil separator element - UT Synthetic	Replace
	Oil - UT Synthetic	Replace
	60 Hz motor ( ≤ 25HP ) grease	Replace
	Drive coupling element	Replace
	Pipe coupling element	Replace
	Intake valve kit	Replace
	Actuator kit	Replace
	MPV kit	Replace
	BDV kit	Replace
	Solenoid valve	Replace
	Safety valve	Replace
	MOS-ADV kit	Replace
	Control line filter-ADV kit	Check & Replace
	Nylon tubes	Replace
Oil & after coolers - water cooled (External)	Check & Clean	

#- Whichever comes first   \* - As per air filter clog indicator   \*\*- For USA region only

**Table 5. Maintenance intervals**

### NOTE

The above life time guidelines are applicable only to standard operating and regular maintenance conditions recommended in this manual. In the event of changes in the conditions, consult ELGi.

### Precautions

#### A. If the compressor is kept idle

- Isolate the power supply.
- Close the main air outlet valve.
- Drain the water from the condensate system.
- Close the inlet and outlet water valve. (applicable only for water cooled compressors)

#### B. If the compressor is kept idle for more than 6 months

- Follow the above steps.
- Refer to the section "Preservation for long idle storage".

Volume	ELGi Air Lube UT Synthetic	ELGi Air Lube FG
5 litres (1.3 gallons)	000998067	000998077
20 litres (5.3 gallons)	000998068	000998078
210 litres (55 gallons)	000998069	000998079

**Table 6. Compressor oil**

Sl. No.	Motor make	Grease
1	ELGi	ESSO Polyrex EPL
2	SIEMENS	Unirex N3 ESSO
3	WEG	MOBIL Polyrex EM

**Table 7. Electric motor grease**

**⚠ WARNING**

Disconnect all the power at the source before attempt to perform maintenance or make adjustment.

**6.1.2 Maintenance of individual components and systems**

Check all accessories independently to verify that they are functioning as required and replace their components as necessary. **After maintenance restart the compressor as mentioned in section "Operating instructions".**

**6.1.2.1 Pre filter**

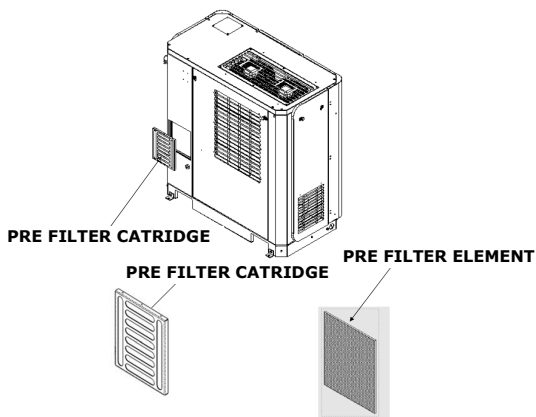

**Fig 11. Pre filter**

**Pre work**

- Switch off the compressor and disconnect power supply to the compressor.
- Close the discharge end ball valve.
- Release air oil tank pressure and allow the tank to cool for a few minutes.

**Requirements**

- Compressed air, new pre-filter element (if needed)

**Maintenance**

- Switch off the machine.
- Refer to the pre-filter cartridge removal & insert procedure.
- Hold or fix the pre-filter assembly in the cleaning area.
- Clean the pre-filter with compressed air at less than 2.5 bar.g (36.3 psi.g) from the reverse or back side of the pre filter cartridge.
- In case of major dust/dirt accumulation in the pre-filter element, wash with clean water or light detergent.
- Do not use any acidic/alkaline chemicals for cleaning.
- Repeat this process based on dust conditions or at regular periodic intervals.

**Suction pre-filter cartridge removal procedure**

**1. Slide Upward**

Hold the pre-filter between the louvers and

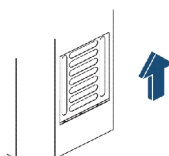

slide upwards slightly until the pre-filter bottom edge is visible

**2. Slide Downward**

When the pre-filter bottom edge is visible, slant the pre-filter forward and slide it downwards away from the compressor

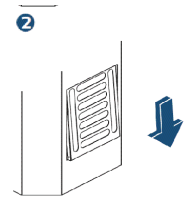

**3. Pull Forward**

When the top and bottom edges of the pre-filter are free from the compressor, move the pre-filter forward to remove completely.

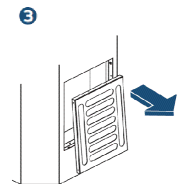

**Suction pre filter cartridge insert procedure.**

For insert sequence procedure from 3-2-1

**6.1.2.2 Air filter**

If the air filter clog indicator shows a red colour (meaning the blocked condition) then the air filter needs to be cleaned or replaced (if the stipulated life has elapsed).

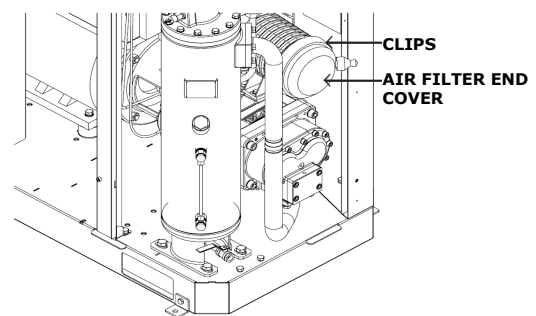

**Figure 12. Air filter**

**Pre work**

- Switch off the compressor and disconnect power supply to the compressor.
- Close the discharge end ball valve.
- Release air oil tank pressure and allow the tank to cool for a few minutes.

**Requirements**

- Compressed air, new filter element (if needed).

**Maintenance**

- Unlock the mounting clips provided on the filter housing.
- Rotate and remove the filter element carefully.
- Clean the filter using moisture free compressed air at less than 2.5 bar.g (36.3 psi.g).
- Clean from the inside to outside.
- Remove the dust ejector from the filter housing cap and clean it carefully.
- Show bright light from inner side of the filter element to inspect for damage or holes that result in leaks. Light

will emerge from the holes, indicating their locations. In case of damages replace the filter element

- Inspect all rubber sealing and their contact surfaces of the housing. Faulty rubber sealing must be replaced immediately.
- Return the dust ejector back in correct (bottom) position.
- Return the filter element back in position, assemble the filter housing cap such that the dust ejector settles in bottom position, and lock the assembly using the mounting clips.
- Inspect and tighten all air inlet connections prior to resuming operation (if necessary).
- Reset the air filter clog indicator.
- If a clean element is to be stored for later use, it must be stored in a clean container.

### 6.1.2.3 Air oil separator

#### Pre work

- Switch off the compressor and disconnect power supply to the compressor.
- Close the discharge end ball valve.
- Release air oil tank pressure and allow the tank to cool for a few minutes.

#### Requirements

- Strap wrench, new separator element, clean cloth.

#### Maintenance

##### Disassembly of the existing separator:

- Hold the separator outer shell by the removed strap wrench and rotate it counter clockwise, until it completely unscrews.
- Ensure the hex adapter stays in the separator head during disassembly.
- Once the recommended life is over, replace it with a new element.

AIR OIL SEPARATOR SHELL

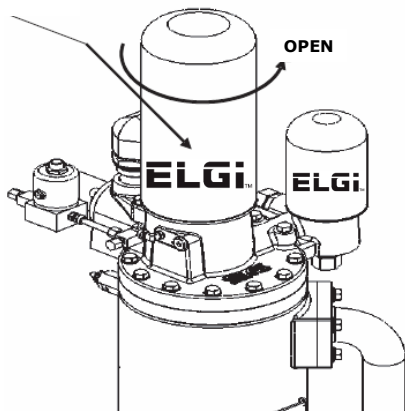

Figure 13. Air oil separator

##### Assembly of a new separator:

- Ensure the O-ring of the separator is damage free.
- Clean the O-ring-seating surface with a clean cloth.
- Apply a thin film of compressor oil on the mating surface of the O-ring.
- Return the separator to its original position and rotate it by hand clockwise.
- Ensure no oil leaks from the mating surface.
- In case of leakage, check the O-ring.
- After tightening by hand, rotate it further for one and a half times.

#### NOTE

*The air-oil separator tank is tested according to standards. Regularly have inspections performed in conformity with local regulations.*

### 6.1.2.4 Oil top up & oil change over

Proper compressor maintenance and operation is crucial for the lubricant to function properly and last till its estimated rated oil hours. The oil product shelf life is of minimum 3 years and maximum 5 years. Products should be kept properly sealed in the original container. Once the seal is broken, the above stated life span of the product is no longer applicable. Products should be stored in proper storage warehouse that is away from direct sunlight and is not exposed to weather elements like rain, typhoon and snow storms. The products should also be stored away from any heat source, high humidity and moisture areas. If drums are stacked on ground level, they should all be stacked horizontally with the bung openings arranged at the 3 and 9 o'clock position.

ELGi recommends that once the seal is broken, all products be used immediately. ELGi does not encourage reuse or recycling of any leftover fluids due to contamination hazard. ELGi will not warrant the quality of the product once the original seal is broken. Also ensure that the oils are not mixed up between brands and types.

Please refer Material Safety Data Sheet (MSDS) for oil spill handling and disposal procedures.

#### Pre work

- Switch off the compressor and disconnect power supply to the compressor.
- Close the discharge end ball valve.
- Release air oil tank pressure and allow the tank to cool for a few minutes.

#### Requirements

- New oil, flushing fluid (if needed)

**NOTE**

- The compressor is originally filled with a particular oil, if you want to change over to other types of oil, perform steps 1, 2 and 3.
- But if you want to change the oil but continue with the same kind (same brand & type) perform steps 1 and 3 only.
- Ensure that you drain at least 90% of oil capacity of the compressor; if not the residual oil can contaminate new oil.
- Ensure no oil spills on anti-vibration mount during maintenance.

**Maintenance**

**Step 1: Draining**

- Remove drain plug from the bottom of the separator tank and drain out all oil. Drain oil while the compressor is warm.
- Remove the pipe and drain plug from bottom of oil cooler. Then completely drain.
- Disconnect all oil pipe work which could trap oil and drain completely.
- Drain oil from the airend discharge pipe after dismantling it.
- Drain oil from the airend by hand rotation.

**Step 2: Flushing (Only for oil change over)**

Check the air-oil separator differential pressure. To flush clean/non-varnished machines, using:

**Mineral/PAO/PAG oils**

- Fill the compressor with the ELGi cleaner (use the same compressor oil fill volume) and run the compressor.
- After 500 hours of running, drain the cleaner as per step 1.
- Refill the compressor with new compressor oil.
- Send a sample\*\* of the compressor oil to ELGi for oil analysis after 300 hours.

\*\*: Applicable only for USA.

**NOTE**

- The cleaner is not recommended to run longer than 500 hours.
- Change the oil filter and oil separator after oil change over.

**Step 3: Filling the oil**

- Add fresh oil; fill it up to the oil fill plug. (initial fill)
- Close the oil fill plug.
- Pour oil into airend, then restart the compressor.
- Allow it to run for about 10 minutes.
- Stop the compressor.

- Unscrew the oil filling plug after 5 minutes so that residual pressure in the tank is vented out through the bleed hole in the oil fill plug.
- Refill the tank up to the oil fill plug. (second fill)
- Restart the compressor.

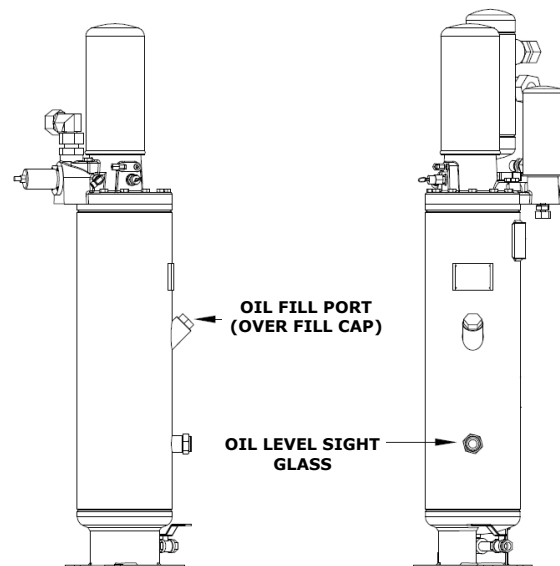

**Figure 14. Air oil separator tank- oil drain**

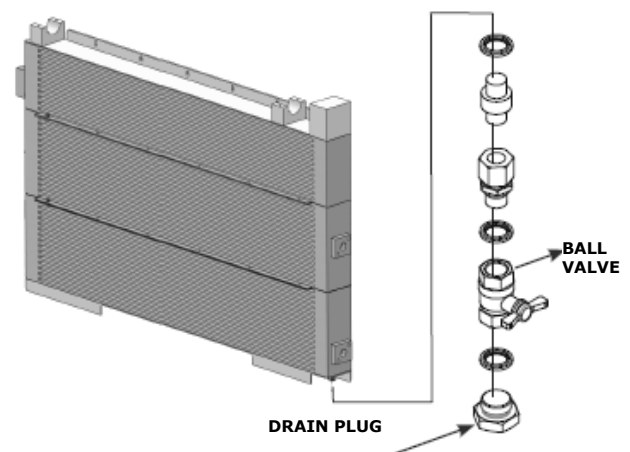

**Figure 15. Cooler oil drain**

**6.1.2.5 Oil filter**

The oil filter is fitted between the oil cooler and the airend unit. The components of the oil filter assembly are shown in the figure. This is a full flow filter with a pleated element. To service this filter, order the consumables kit (available with ELGi service personnel) The procedure for complete servicing of this filter is as follows.

**Pre work**

- Switch off the compressor and disconnect power supply to the compressor.
- Close the discharge end ball valve.
- Release air oil tank pressure and allow the tank to cool

for a few minutes.

### Requirements

- Strap wrench, new oil filter, O-ring, and clean cloth.

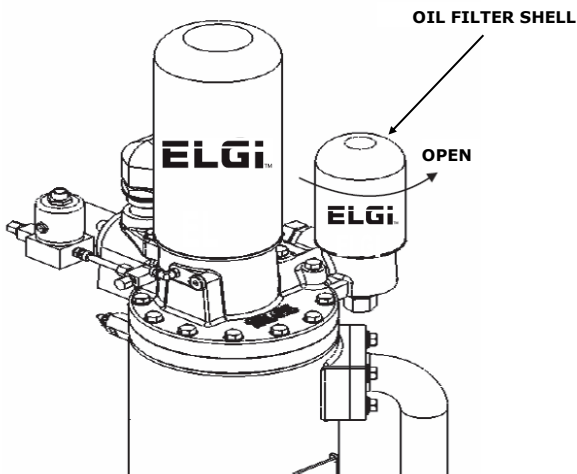

Figure 16. Oil filter

### Maintenance

#### Disassembly of the existing oil filter:

- Isolate the machine from the service line, vent separator tank pressure, and allow the tank to cool for a few minutes.
- Hold the filter shell and rotate it counter clockwise using the strap wrench.

#### Assembly of the new oil filter:

- Ensure the O-ring of the filter is damage free.
- Clean the seating surface with clean cotton.
- Apply a thin film of compressor oil on the mating surface of the O-ring.
- Return the filter to its original position and rotate it clockwise manually. After tightening, rotate it further by hand for one and a half times.
- Ensure no oil leaks from the mating surface.

### NOTE

Suspended particulate matter should be less than 150spm to achieve the specified consumable life. Guarantee becomes void if the compressor is operated above its intended pressure.

### 6.1.2.6 Intake valve

### WARNING

Valves should not be opened when pressure is applied.

### NOTE

The maintenance of following parts (valves) demands highly skilled authorized personnel. So, it is recommended that an ELGi service engineer does the maintenance.

### Pre work:

- Switch off the compressor and disconnect power supply to the compressor.
- Close the discharge end ball valve.
- Release air oil tank pressure and allow the tank to cool for a 10-minutes.

### Requirements :

- Soft cloth, grease, liquid cleaner, Allen keys, screw driver, spanner, pressure gauge, service kit (if needed).

### Procedure :

#### Function of NRV-flaps

#### Dismantling:

- The valve must be completely dismantled from the compressor. Then remove the bearing bolts (4), pin (5), and the NRV-flap..

#### Cleaning:

- Clean the interior of the housing with a liquid cleaner. Wipe any Loctite residue from threads. Seat and sealing areas must by no means be damaged.

#### Reassembly:

- Wet a bearing bolt with Loctite 242 and screw it into the thread. Install the NRV-flap or the NRV-flap and counterweight in the housing according to the drawing.
- Press the pin (4) through the bearing bores into the pre-assembled bearing bolt. Wet the second screw with Loctite 242 and screw it in. Lock both screws with 50 N-m (30.87 lb-ft).

#### Function testing:

- Check easy movement of the NRV-flap manually. It must have slight axial play and not touch the housing.

### 1. Rotary drive unit

- The valve must be completely dismantled from the compressor. (Additionally, the control discs need to be closed by using the pressure air signal as explained before)
- Turn out Tensilock screws (10) and remove the control disc (1) (with a magnet). (Drain pressurized air.).
- Remove the plastic plug (11). Turn out the MHT-nut (15) and remove the 2 rings (13 & 14) below.
- Attention: The spring (6) is pretensioned. When screwing off the cover (8), therefore, press it by hand onto the cover when turning out. Remove the sealing ring (7), piston unit (9), spring (6), rod (12), and the remaining 2 rings (16& 17).

#### Cleaning:

- Wipe any residual loctite from the rod (12). Clean the working area of the piston unit (9) with the liquid cleaner and soft cloth. Grease the screw drive of the rod (12) and piston working area with AUTOL TOP 2000.

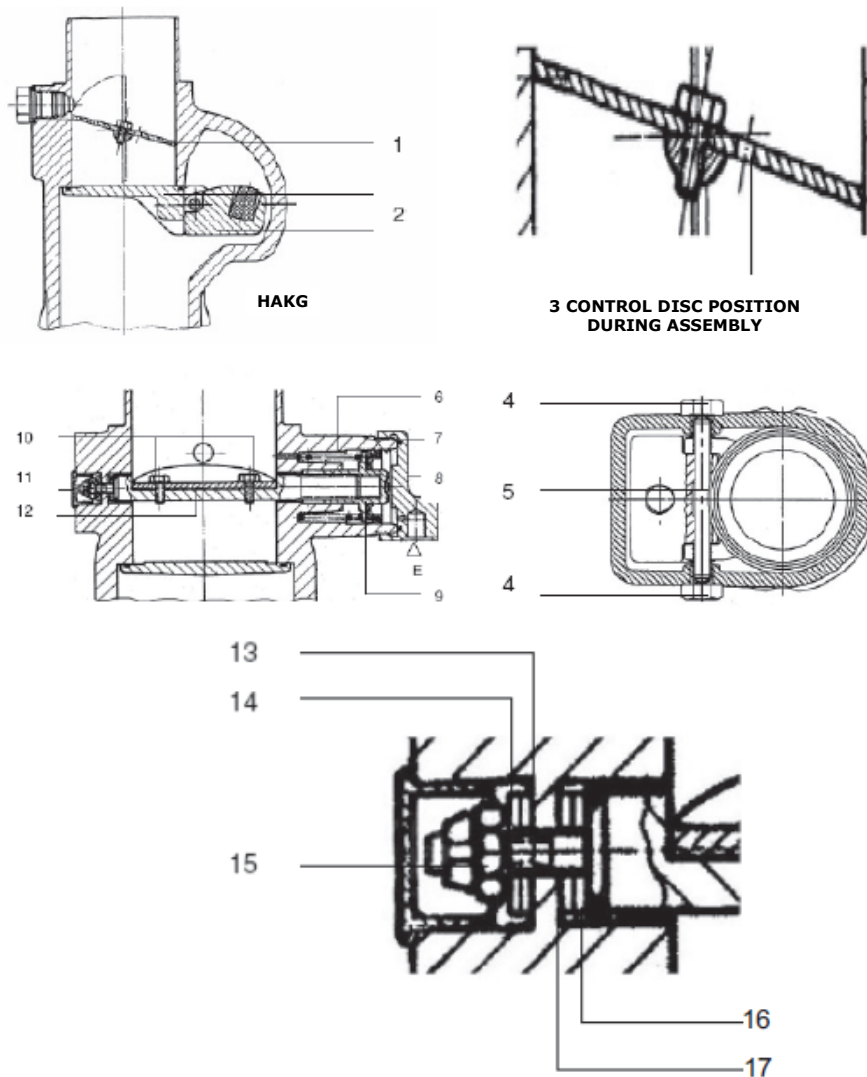

**DETAIL: ROTARY DRIVE UNIT**

**Figure 17. Intake valve**

The flattened medium part of the rod and the thread must be absolutely free of grease. Seat and sealing areas must by no means be damaged.

**Reassembly:**

- Insert two discs (16&17) into the housing according to the drawing. The sinter area of the first disc (17) (grey) must point away from the housing in the direction to the second steel disc (16). Turn the piston unit (9) on the rod (12) until it stops. Hold the rod in a way that the flattened part looks upward. Then turn the piston unit back until for the first time a guiding area is parallel with the flattened part of the rod.
- Insert the spring (6) according to the drawing into the housing against spring pressure in a way that the flattened part points to the counterweight section of the housing.
- Block the rod (12). Install two discs (13&14) according to the drawing. The sinter area of the first disc (13)

(grey) must point away from the housing in the direction to the second steel disc (14). Wet the MHT-nut (15) with Loctite 270, lock it, and loosen it again by a 1/6 turn. Insert the sealing ring (7) in the groove provided in the cover (8). Put the cover (8) on top and fix it by turning. Connection E must look downward. Loosen blocking of the rod.

- Install the control disc (1) according to the drawing. The bore for idle operation must always point to the counterweight section of the housing. Wet Tensilock bolts (9) with loctite 270 and lock them. Lock with 9 N-m (6.63 lb-ft). Install the plastic plug according to the drawing. .

**Function testing:**

- Connect to pressurized air and test smooth opening/closing for several times. Adjust by turning the MHT-nut (15) in either direction, if needed. Pay attention to Loctite. If the time is too long, clean Loctite off the nut and wet again .



**NOTE**

After completion of intake valve assembly in package, ensure to verify the performance

**6.1.2.7 Blow down valve**

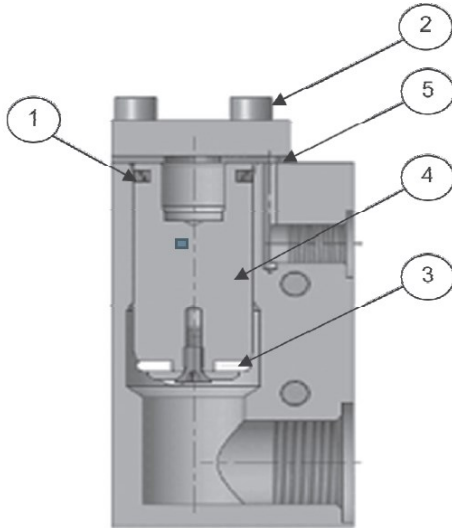

**Figure 18. Blow down valve**

**Pre work**

- Switch off the compressor and disconnect power supply to the motor.
- Close the discharge end ball valve.

**Requirements**

- Liquid cleaner.

**Maintenance**

**Complete Service and Dismantling**

- Dismantle the valve completely from the compressor.
- Unscrew locking screws (2).
- Remove the piston unit (4) along with the gasket (5)

**Cleaning**

- Work areas and sealing areas of the housing and their threads must be cleaned with the liquid cleaner and any residual Loctite removed.
- Piston work areas have to be greased by any means. Seat and sealing areas must not be damaged.
- Reassembly
- Insert the piston unit (4) into the housing.
- Assemble the gasket (5) cover plate and tighten the locking screws.

**Function testing**

- Test the valve function after each service or inspection at the running compressor.

**Inspection**

- Dismantle the valve and check the component for wear.

- Work areas and sealing areas of the housing and their threads must be cleaned with the liquid cleaner and any residual Loctite removed.
- Piston work areas have to be greased by any means. Seat and sealing areas must not be damaged.
- Reassemble the valve as described above and test its functioning.

**6.1.2.8 Minimum pressure valve**

**⚠ WARNING**

Extreme caution should be taken while removing the cap or cover from the body because of the spring.

**Pre work**

- Switch off the compressor and disconnect power supply to the compressor.
- Close the discharge end ball valve.
- Release air oil tank pressure and allow the system to cool for a few minutes.
- Release the receiver tank and downstream pressure.

**Requirements**

- New MPV kit, allen key, grease.

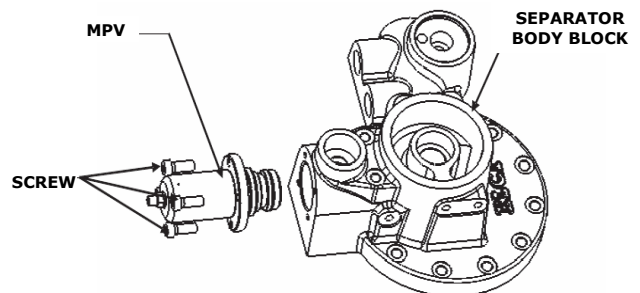

**Figure 19. Minimum pressure valve**

**Maintenance**

**MPV Replacement:**

- Isolate the machine from the service line, vent separator tank pressure and allow the system to cool for a few minutes.
- Release the receiver tank and downstream pressure.
- Unscrew the four screws.
- Remove and replace the old MPV kit with a new one.
- Grease the O-ring groove in the new MPV kit.
- Assemble the MPV kit and reinstall the spring and cap.
- Tighten the bolts.
- Adjust stud protrusion (6mm/0.236 inches) to achieve a minimum pressure of 4.5 bar.g (65 psi.g)

**6.1.2.9 Thermal valve**

**Pre work**

- Switch off the compressor and disconnect power supply



to the compressor.

- Close the discharge end ball valve.
- Release air oil tank pressure and allow the tank to cool for a few minutes.

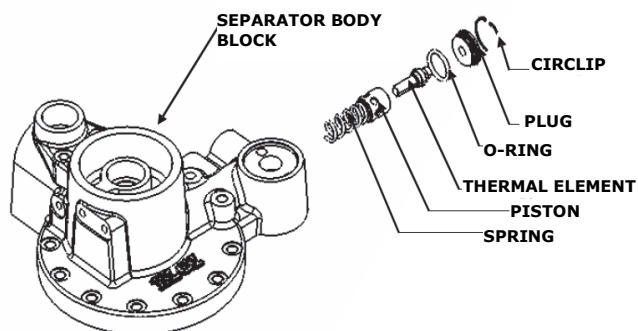

**Figure 20. Thermal valve**

#### Requirements

- Pliers, screw driver, new thermal valve element, new O-ring.

#### Procedure

##### Replacing thermal Valve

- Remove the thermal valve element from the thermal valve block body
- Inspect and clean seating area in the housing
- Replace with a new thermal valve.

### 6.1.2.10 Electric motor greasing

#### Pre work

- Switch off the compressor and disconnect power supply to the compressor.
- Close the discharge end ball valve.
- Release air oil tank pressure and allow the tank to cool for a few minutes.

#### Requirements

- Recommended grease, cleaning cloth, grease gun.

#### Procedure

- Stop the motor and lock out the switch.
- Thoroughly clean the grease inlet fitting or plug. If the motor has a plug, remove the plug and clean the inlet.
- Remove the drain plug and wipe out any hardened grease.
- Slowly pump the grease into the grease inlet until the new grease comes out of the drain plug.
- Start the motor and let it run for a minimum of one hour to expel any excess grease from the drain opening before re-installing the drain plug.
- Stop the motor and lock out the switch.
- Re-install the drain plug.

- Put the motor back in operation.

### 6.1.2.11 After and oil coolers

#### Pre work

- Switch off the compressor and disconnect power supply to the compressor.
- Close the discharge end ball valve.
- Release air oil tank pressure and allow the tank to cool for a few minutes.

#### Requirements

- Pliers, allen keys.

#### Maintenance

##### External surfaces:

- Isolate the machine from the service line
- Vent the separator tank pressure before attempting maintenance
- Open both the LH panel and cooler inspection cover
- Use compressed air below 2.5 bar/36.3 psi maximum to clean the outer surface of the cooler. Supply a jet of air in the direction opposite to cooling airflow direction
- After cleaning the outer surface of the cooler properly close the cooler with a cleaning plate and an LH panel.

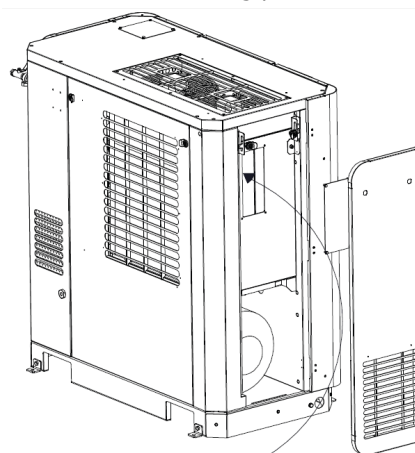

**Figure 31. Cooler external surface**

### 6.1.2.12 Cooler prefilter accessory (optional)

#### Cooler prefilter cleaning & maintenance instructions

- Switch off the machine.
- Lift upward & take out the cooler pre filter from the compressor.
- Hold or fix the prefilter assembly in the cleaning area.
- Clean the pre-filter with compressed air at less than 2.5 bar.g (36.3 psi.g) from the reverse / back side of the cooler prefilter.
- In case of major dust / dirt accumulation in the pre-filter element, wash with clean water or light detergent. Do not rinse.

- Do not use any acidic / alkaline chemicals for cleaning.
- Repeat the process based on dust conditions or regular periodic intervals.

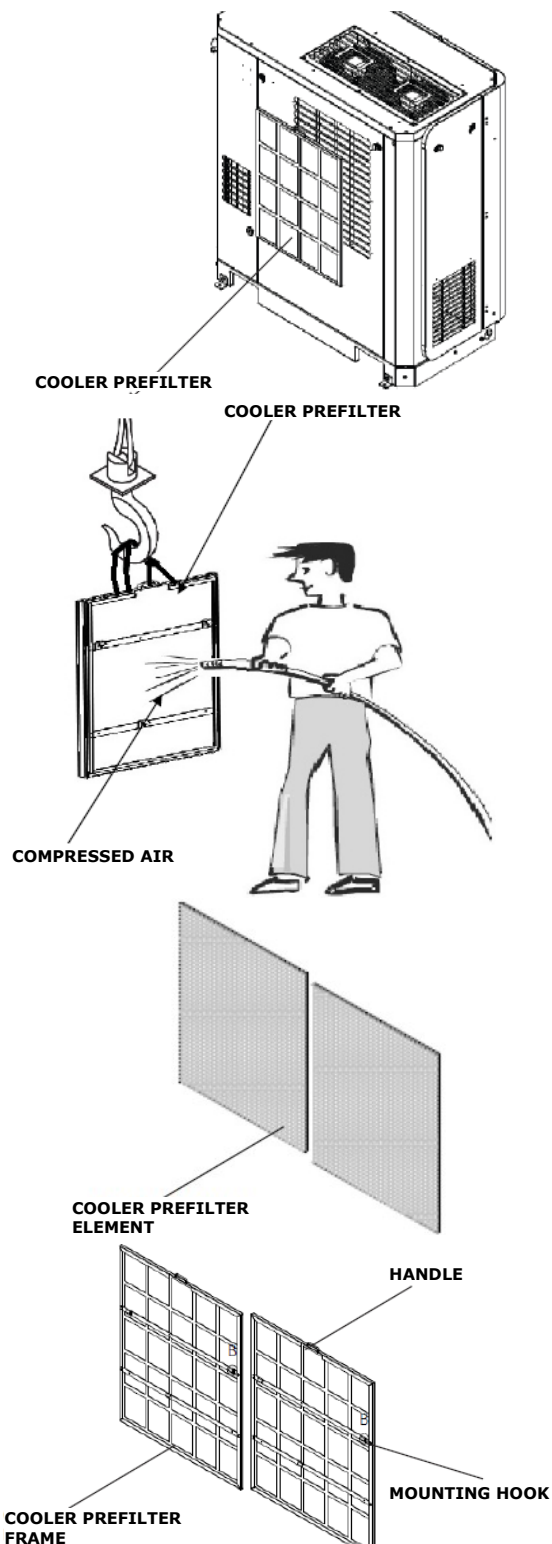

**Figure 22. Cooler prefilter accessory**

### 6.1.2.13 Drive coupling

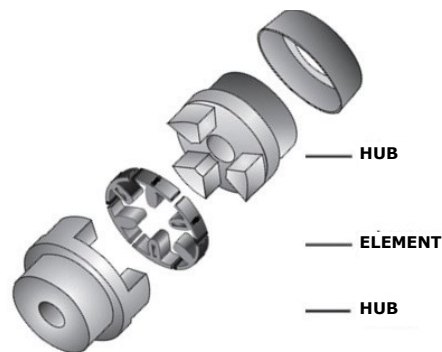

**Figure 23. Drive coupling**

#### Pre work

- Switch off the compressor and disconnect power supply to the compressor.
- Close the discharge end ball valve.
- Release air oil tank pressure and allow the tank to cool for a few minutes.

#### Requirements

- Spanners, new coupling element.

#### Maintenance

Replacing the coupling element:

- Open the cooler side panel covers
- Open the coupling guard from the adapter ring .
- Remove the three coupling screws and slide coupling element on the shaft spline to free the coupling element
- Replace the old coupling element with a new coupling element
- Tighten the coupling screws to the specified torque
- Assemble the coupling guard and cooler side panel cover
- Inspect every three months to ensure screws stay tight.

### 6.1.2.14 Moisture separator and auto drain valve

#### Pre work

- Switch off the compressor and disconnect power supply to the compressor.
- Close the discharge end ball valve.
- Release air oil tank pressure and allow the tank to cool for a few minutes.

#### Requirements

- Spanner, screw driver, player, caustic soda.

#### Maintenance

##### Dismantling

- Disconnect the pressure sensor line on top of the moisture separator

- Manually drain the condensate by using the manual discharge plug located at the bottom of the auto drain assembly.
- Remove the moisture separator from the machine
- Remove the bottom housing from the top housing.
- Remove the auto drain assembly from the bottom housing.

**Cleaning and replacement**

- Inspect the O-ring and replace it with new one in the kit, if necessary
- Clean the housing and all other inner parts
- Ensure the mating surfaces of the O-ring are clean and free from foreign particles
- The auto drain assembly is not serviceable and must be replaced with new one if not functioning

**Reassembly**

- The vortex generator cone and the cyclone arrestor need only to be tightened moderately by hand. Over-tightening may lead to failure or damage. ELGi assumes no responsibility for failure or damage resulting from such incorrect installation.
- Reassemble the auto drain assembly with the bottom housing and the bottom housing with the top housing
- Reassemble the moisture separator in the machine and connect the all pipe lines, pressure sensing line, and drain line
- Restart the machine and check for any leaks at the joints. If leaks occur, stop machine and wait for sump pressure to drop to atmospheric pressure.
- Remove the O-ring as described above, and inspect and clean it
- Ensure that the mating surfaces are clean and refit the O-ring

**WARNING**

Moisture separator may be heavy. Caution should be taken while removing it from the machine.

**NOTE**

- Avoid damaging the housing when removing or tightening the moisture separator. Do not use a pipe wrench. If necessary, use a locking strap clamp/wrench
- Install the separator in a vertical upright position, observing the correct direction of air

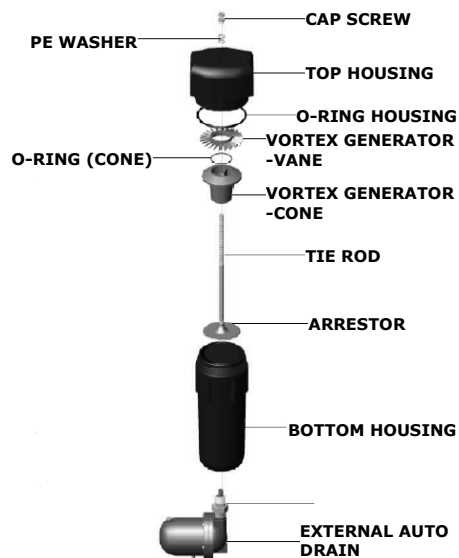
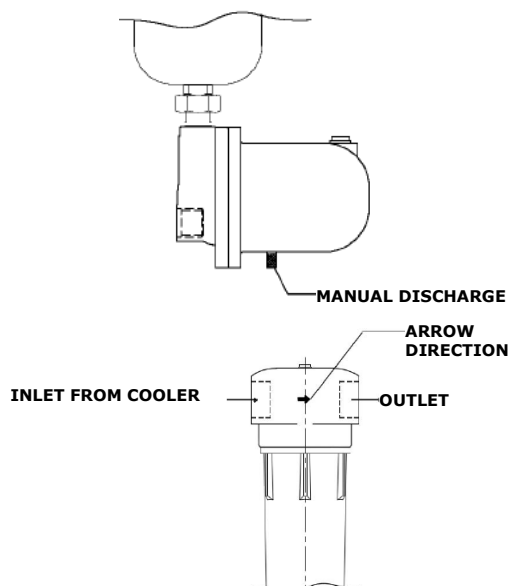

**Figure 24. Moisture separator and auto drain valve**

### 6.1.3 Use genuine spare parts

It is very important to use genuine spare parts, to ensure that your compressor work as new for its lifetime. Spurious spares may seem less expensive initially, but they severely compromise on quality. Spurious parts will prove cost-ineffective in the long run, and may even result in total damage of the machine or cause serious accidents. The table includes certain critical spurious parts. It is not an exhaustive list, and you are strongly advised to avoid all other spurious spares that this table does not cover. Be aware of the consequences of using spurious spares including but not limited to the ones described in the table.

Effect	Spurious part	Remarks
Higher power consumption	Air oil separator	Due to dense filtration media, it creates in additional pressure drop and so causes additional power consumption. Every 1 bar (14.5 psi) of pressure drop results in ~7% additional power consumption.
	Lubricant	Spurious oil loses its properties soon and may get solidified causing the rotor to malfunction.
Reduced performance	Air oil separator	This imposes 10% additional resistance for air flow and creates more pressure drop and thus additional load on motor. Inadequate separation deteriorates air quality, reduce the performance, and damages downstream components. It also results in huge oil loss (1L / 200hr).
	Oil filter	Contaminants are not filtered properly and the contaminated oil affects the critical parts of air end. Thus it reduces performance and life (33% reduction) of the air end, air oil separator etc. Contaminated oil also cause clogging and reduces the cooler performance.
	Air filter	Dust carries over to the system and causes the same problems as caused by the spurious oil filter
Safety hazard	Air oil separator	Inadequate earthing can cause a separator to collapse (25% risk). Inadequate earthing can also cause fire and destroy the entire machine.
Cost		Higher power consumption means a higher operating cost. Reduced performance leads to extra functioning and operating cost. Spurious parts will damage the other components and accelerate maintenance frequency and cost. Higher consumption of consumables like oil (due to the use of spurious parts) will result in, increased cost.



## 6.2 Troubleshooting

This guide lists the most likely indications with possible causes. For any problem, follow the diagnosis in sequential order as mentioned in the following charts. Before doing any work in the compressor, be sure that electrical supply has been cut off and the entire compressor is depressurized.

Problem	Cause	Solution (go sequentially)
<b>Compressor not starting</b>	Power supply not available	Restore incoming power supply
	Incoming voltage is below limit	(1) Correct the incoming voltage.
		(2) Ensure isolator is within 5m (16 ft) from the compressor.
		(3) Ensure sufficient power back up
		(4) Select and use the correct cable size.
	Emergency stop switch in pushed	Rotate counter clockwise direction and release
	Emergency stop switch malfunction	Clean or replace the emergency switch.
		Tighten the wires at terminals
	Isolator fuse blown.	(1) Select correct fuse rating from selection chart.
		(2) Check and correct the short circuit within the control panel.
		(3) Dedicated isolator to be provided to the compressor.
		(4) Check and correct the motor winding/ body short after
	Incoming phase-to-phase voltage imbalance of more than 5V	Correct incoming voltage.
		Adjust main incoming transformer tapping.
		Correct the power factor to less than unity.
	Incoming phase to earth voltage	Correct the incoming voltage.
	Control MCB malfunction	Replace MCB
	Control fuses inside compressor control panel blown	Check for any short circuit or loose connection.
Replace the solenoid valve / control transformer if defective.		
Replace the glass fuse (2A for Neuron, 1A for the control circuit).		
Control transformer fuse blown	Replace the control transformer if defective.	
	Replace glass fuse (0.25A for Neuron, 0.5A for the control circuit).	
No power supply to Neuron controller.	(1) Replace control transformer fuses.	
	(2) Ensure tight connection of the 24V power supply connector	
	(3) Replace control transformer (50VA).	
No display in Neuron controller	(1) Replace the control transformer (50VA).	
	(2) Replace the control fuse.	
	(3) If 24V power supply to Neuron is okay then replace with anew Neuron micro controller.	

Problem	Cause	Solution (go sequentially)
<b>High discharge oil temperature</b>	Oil level is low	(1) Check and refill oil to correct the level. (in stopped condition)
		(2) Refer diagnosis procedure for high oil carry over.
		(3) Arrest oil leaks
		(4) Ensure the correct grade of oil is used.
	Room temperature is higher than outside ambient temperature by 30°C (86°F)	Improve ventilation in compressor room
	Oil cooler clogged externally	Clean the cooler assembly / cooler pre filter mesh (if available) externally by first using a fibre brush and then blowing compressed air at 2.5 bar.g(36.3 psi.g).
		For sticky dust, remove the cooler, close all the cooler ports with dummy plugs and do a water-wash with soap oil.
		Install the cooler prefilter mesh.
	Cooling fan rotating in wrong direction.	Check and correct the wiring connection to the cooling fan.
		Replace with correct fan type.
	Check fan motor fuse	Replace the fuse if blown.
		Replace with the 2A fuse.
	Cooling fan not working.	Check and ensure the neutral connection is connected.
	Temperature sensor malfunction	Replace the sensor.
		Tighten/recrimp the connection with adaptor.
	Oil filter clogged	Replace oil filter.
		If required replace the oil (based on the condition of oil) and run the compressor.
	Thermal valve malfunctioning	Replace the thermal valve element.
	Oil injection orifice choked or improper size	Clean the oil injection orifice.
		Replace with correct size.
Air filter clogged	Clean or replace the air filter	
Separator element clogged	Check pressure drop is less than 1bar (14.5 psi).	
	Replace oil.	
	Replace separator element.	
Poor quality of oil	Replace oil.	
Oil cooler clogged internally	Check for pressure drop across the oil cooler if less than 1.5 bar (22 psi).	
	Check and clean the cooler internally with 20L of isopropyl alcohol + toluene mixture in the 1:1 ratio and circulate for 4 hours with external 1 HP pump.	
	Refit the cleaned cooler and, if required, replace oil (based on condition of the oil) and run the compressor.	

Problem	Cause	Solution (go sequentially)
<b>High oil carry over</b>	High oil level	Drain excess oil and maintain the recommended oil level.
	Oil is milky	Replace oil and maintain the recommended level.
	Scavenge return line non return valve (NRV)/ orifice clogged	1) Remove the return line NRV/orifice and clean it thoroughly.
		2) Change/clean the air filter.
	Scavenge return line tube clogged	Remove and clean the clogged scavenge return line tube.
	Scavenge return line tube gap not maintained (not applicable EG11 to EG22)	Remove the return line tube from the separator and correct it.
	The spin-on separator internal pipe thread damaged (applicable to EN series)	Replace the internal pipe.
	High discharge oil temperature (DOT)	Refer to the diagnosis procedure for high DOT.
	Improper grade of oil	Use ELGi recommended Air lube oil.
	Separator punctured/collapsed (not applicable to EG11 to EG22 units)	Replace with new separator.
	Separator element bonding ruptured (not applicable to EG11 to EG22 units)	Replace with new separator.
	Compressor runs at lower pressure than normal pressure.	1) Use suitable higher capacity compressor or match demand to compressor capacity.
2) Arrest all line leakages.		
Minimum pressure valve (MPV) opening earlier than at the specified opening pressure* 4.5 bar.g (65.26psi.g). * 3.5 bar.g ( 50.8 psi.g) for compressors with working pressure 4.5 bar.g	Replace MPV kit/assembly.	
<b>High tank pressure</b>	Neuron microcontroller pressure settings: 1) Unload pressure set value is above specification. 2) High tank pressure set value is below specification.	Check and correct the unload pressure and high tank pressure values in Neuron micro-controller
	Intake valve malfunction	1) Check and replace intake valve kit if required.
		2) Check the solenoid valve and clean or replace if required.
		3) Check and replace the actuator kit if required.
	BDV malfunction	Check/replace
	Compressor started with air outlet ball valve closed	Open the outlet ball valve.
	Solenoid valve malfunction	Check the solenoid valve and clean or replace if required.
	Neuron microcontroller malfunction	Replace the Neuron microcontroller
	Pressure transmitter malfunction	Replace the pressure transmitter
MPV stuck up (check with pressure gauge in AOS tank )	Replace the MPV kit.	
Separator element choked	Replace the separator element	

Problem	Cause	Solution (go sequentially)
<b>Loading/unloading Problem</b>	No control air supply to solenoid valve	Replace / connect
	Solenoid valve malfunctioning	1. Replace the solenoid valve assembly
		2. Clean the orifice
	No electrical supply for energising the solenoid valve	Replace the Neuron microcontroller
	Intake valve malfunctioning	Check and replace the intake valve kit.
	Blow-down valve malfunctioning	1. Clean or change BDV assembly.
		2. Clean the orifice.
	MPV malfunctioning	1. Check and change the MPV kit.
		2. Check and change the MPV assembly
	Pressure regulator (applicable only to EG 55 to EG 250) setting lower than working pressure	1. Check and reset the pressure regulator setting to working pressure+0.3 bar (4.35 psi).
		2. Change the pressure regulator assembly.
	Actuator failure (applicable only to EG 55 to EG 250)	Check and change the actuator / kit / assy.
	1. Air requirement is more than compressor capacity	1. Replace the compressor 2. Arrest all pipeline leakages.
	2. Working pressure is lower than required application pressure.	
3. Excess pressure drop in pipe line.		
Pressure transmitter malfunction	1. Tighten the lap cable	
	2. Replace the lap cable	
	3. Replace the pressure transmitter	
	4. Replace the Neuron microcontroller	
Malfunction of R04 relay (loading/ unloading relay) in Neuron microcontroller	Replace the Neuron microcontroller	
Unload mode enabled in Neuron microcontroller	Disable 'unload mode' in operator settings of the Neuron microcontroller	



Problem	Cause	Solution (go sequentially)
<b>Pressure not built up</b>	Inlet air pre-filter mat clogged	Clean/change pre-filter mat by following these steps: Switch off the machine. Squeeze and pull out the pre-filter mat from the canopy. Clean pre-filter with compressed air at less than 2.5 bar /36.3 psi Refit the filter after cleaning.
	Clogged air filter element	Clean/change air filter element.
	1. Air requirement is more than compressor capacity	1. Replace compressor 2. Arrest all pipeline leakages.
	2. Working pressure is lower than required application pressure.	
	3. Excess pressure drop in pipe line.	
	No control air supply to solenoid valve.	Replace / connect the control line tubes.
	Solenoid valve malfunctioning	1. Replace the solenoid valve assembly
		2. Clean the orifice
	No electrical control supply to solenoid valve	Replace the microcontroller
	Intake valve malfunctioning	Check and replace intake valve kit.
	Blow down valve malfunctioning	1. Check and change the BDV assembly.
		2. Clean the orifice.
	MPV malfunctioning	1. Check and change the MPV kit.
		2. Check and change the MPV assembly
Pressure regulator (applicable only to EG 55 to EG 250) setting lower than working pressure	1. Check and reset pressure regulator setting to working pressure+0.3bar (4.35 psi).	
	2. Change pressure regulator assembly.	
Actuator failure (applicable only to EG 55 to EG 250)	Check/change actuator / kit / assembly.	
Separator element choked (increase in pressure drop across separator)	Replace separator element. If required, replace the oil (based on condition of the oil) and run the compressor.	

## 6.3 Decommissioning, dismantling and putting out of service

If you do not intend to use the compressor or any of its parts, you must dismantle and putting out of service. These tasks must be carried out in compliance with the standards in force of that particular country.

### 6.3.1 Waste disposal

- Use of compressor generates waste. The residues from agricultural, industrial, crafts, commercial and service activities must be treated as waste, which needs to be disposed off properly. Deteriorated or obsolete machines are also classified as waste.
- Special attention must be given to active carbon filters as they cannot be included in urban waste. Observe the waste disposal laws in force where the compressor is used.
- It is mandatory to record loading or unloading of exhausted oils, obsolete machines and toxic harmful wastes that derive from heavy or light industry processes.
- It is especially important that exhausted oils be disposed off in compliance with the laws in the countries of use.

### 6.3.2 Dismantling the compressor

- Dismantle the compressor in accordance with all the precautions imposed by the laws in force in the country of use.
- Before dismantling, request an inspection by the relevant authorities. Disconnect the compressor from the electrical system.
- Eliminate any interfaces the compressor may have with other machines, making sure that interfaces between remaining machines are unaffected.
- Empty the air oil tank containing the lubricating oil and store in compliance with the laws in force.
- Proceed with the disassembly of the individual compressor components and group them together according to the materials they are made of: Steel, Stainless Steel, Aluminium and plastic parts.
- Then scrap the machine in compliance with the laws in force of the country of use.

### 6.3.3 Decommissioning the compressor

- Remove the foundation for the compressor.
- Unplug the power cable entry to the compressor.
- Drain the oil from the cooler and air oil tank. Dispose of it properly.
- Make sure all the compressed air is vented out through ball valves and safety devices residing in the compressor.
- Ensure that all the external supply lines have been properly disconnected from the compressor before decommissioning.

### 6.3.4 Disposal of consumables and replaced parts

- The moisture condensate separated from the compressed air contains oil particles. Disposal of condensate and filter element is to be done in accordance with the pollution control norms prevailing at the time of compressor installation or use.
- Parts of the compressor that are replaced have metal and rubber components. These may be recycled and disposed off according to pollution control regulations, respectively.
- Rubber items such as AVMs, coupling elements, and O-rings should be disposed and replaced before running again.

#### NOTE

*ELGi is not responsible for the disposal of old oil or condensate. It is the responsibility of customer to dispose of the foregoing in accordance with local environmental statutory laws.*

#### WARNING

*The compressor does not give any warnings during short operating times. If it is operated below the dew point and moisture condensate may mix with oil. This will reduce the lubricating quality of the oil and lead to damage of compressor.*



### 6.4.1 ELGi customer care system (ELGi CCS)

ELGi provides dedicated customer care and after-sales support through the ELGi customer care system (CCS), a computerized system developed in-house. The CCS aims to minimize the time taken to resolve customer complaints.

#### Service requests/complaints

The CCS toll-free telephone number 1800-425-3544 (accessible within India through BSNL and MTNL lines) takes the customer's call to our centralized customer care center in Coimbatore. Customers can register their service requirements or complaints here.

A unique tracking number is generated for each call logged by the CCS. The customer receives an automatic e-mail acknowledgement with the tracking number and details of the call for reference.

A service engineer is assigned to the call, and the date and time of the engineer's visit are communicated to the customer by e-mail. Every requirement or complaint must be resolved and closed in the CCS within a specified time limit, failing which the complaint is automatically brought to the notice of the manager. If the issue remains unresolved, it will get escalated to the managing director. The CCS ensures that not only the customer complaints are logged but they are also attended to on time, every time.

#### Enquires

A number of calls received by the CCS relate to customer queries regarding products and spare parts. The details are noted, and basic information on product specifications and usage are provided. The caller is then referred to a salesperson at the head office or the appropriate branch for follow-up.

#### The CCS database

The CCS also creates a database of customers, adding details of every new customer who calls, thereby building a large pool of installation details. These details are used to provide value-added services to improve customer satisfaction with ELGi products.

#### CCS-working hours

The ELGi CCS works for six days a week from 08:30 to 21:30 IST (Monday to Saturday).

#### Multi-lingual capability

The coordinators at the CCS are multi-lingual. They can handle calls in English and all the major regional languages of India.

**Coverage:** The CCS toll-free number 1800-425-3544 is accessible from the following areas:

- **Southern Region:** Tamil Nadu, Karnataka, Kerala, Puducherry, Andhra Pradesh, Telangana, Andaman & Nicobar Islands.
- **Western Region:** Maharashtra, Gujarat, Madhya Pradesh, Goa, Lakshadweep Islands.
- **Eastern Region:** Orissa, Chhattisgarh, Jharkhand, West Bengal, Bihar and the North-Eastern states.
- **Northern Region:** Rajasthan, Uttar Pradesh, Delhi, Haryana, Punjab, Uttaranchal, Himachal and Jammu & Kashmir.

**Contact Numbers:** You can contact CCS also with the following numbers:

**Telephone:** 0422-2589206 / 241 / 242 / 243/ 244 / 245 / 97900 21100

**Fax:** 0422-2589240

Please send the following details to the mail, thus enable us to take immediate action.

1. Name of the customer
2. Compressor model
3. Fab. number
4. Contact person name
5. Phone number
6. Nature of complaint
7. Hour meter reading

You may use the CCS by sending e-mail to: **ccs@elgi.com**

#### Customer satisfaction survey

If you have used the CCS, you may be contacted for your feedback on our after-sales support. Your response helps ELGi to improve its service.

#### International customers:

Refer contact information at the end of this manual book

### 6.4.2 ELGi genuine spare parts

When ordering spare parts, refer to the lists provided in the parts manual and identify the part number. Specify the part number and quantity, in addition to the name plate details. Global support center of ELGi ensures the supply of the quality spares on time. Ensure that you are using the genuine spare parts so that your Compressor will be working efficiently and effectively. Refer to section 6.1.3 for details on need of using genuine spares.

Please contact our After sales team for any compressor accessory requirements like VFD, Air-Dryer, etc.

### 6.4.3 Air audit

We extend our proven capabilities in energy efficiency initiatives by carrying out air audits for our customers.

ELGi conducts audits and trains end users in key energy oriented functional areas. The audit reports prepared by ELGi experts' team include recommendations on short,

medium and long term measures for energy conservation, along with financial estimates and analysis for implementation.

This air audit objective is to provide the customer:

- The framework for systematic collection of data relevant to the efficient operation of compressed air systems.
- A thorough analysis about the performance of the compressed air system, identifying potential electricity savings and to provide sound recommendations for implementation of energy efficiency initiatives.

Data analysis will be comprised of the information about different areas such as air leakages, inappropriate use of compressed air, compressed air system network, compressed air system supply including compressor internal maintenance conditions and even more.

The final report issued to the customer end will serve the purpose of assisting concise, consistent and complete presentation of the analysis, findings and recommendations arising from a compressed air system audit.

Depending on the measurement, reporting and cost requirements from the customer end, the intensity in level of audit (base level or investment level) will be decided. Also post implementation monitoring after air audit will be provided if requested from the customer end.

For further information on air audit contact ELGi.

**E-Mail:** [ccs@elgi.com](mailto:ccs@elgi.com)



### 6.5.1 Conversion tables

Description	From	To	Multiply by
Length (L)	Inches	Millimetres	25.4
	Metres	Inches	39.37
	Feet	Millimetres	304.8
	Metres	Feet	3.281
	Inches	Thou	1000
	Millimetres	Micrometres	1000
Area (A)	Square metres	Square feet	10.765
	Square feet	Square inches	144
	Square inches	Square millimetres	645.16
Volume (V)	Cubic metres	Cubic feet	35.315
	Cubic feet	Cubic inches	1728
	Cubic metres	Litres	1000
	Cubic feet	Litres	28.32
	US gallons (liq)	Litres	3.785
	Imperial gallons (liq)	Litres	4.546
Volumetric flow (Q)	Cubic feet per minute (cfm)	Cubic metres per hour (m <sup>3</sup> /h)	1.6988
	Cubic feet per minute (cfm)	lpm	28.32
	Cubic metres per hour (m <sup>3</sup> /h)	lpm	16.667
	Cubic metres per minute (m <sup>3</sup> /min)	lps	16.667
Mass (M)	Kilograms	Pounds	2.205
	Kilograms	Grams	1000
	Kilograms	Ounces	35.27
Pressure (P)	kg f/cm <sup>2</sup> g	psi g	14.223
	psi g	Pascal	6895
	bar g	kg f/cm <sup>2</sup> g	1.0197
	bar g	psi g	14.503
	psi g	kg f/cm <sup>2</sup> g	0.0703
Temperature (T)	Degree Celsius (°C)	Degree Fahrenheit (°F)	°F = 9(°C)/5 + 32
	Degree Celsius (°C)	Kelvin (K)	K = °C + 273.15
	Degree Fahrenheit (°F)	Degree Rankine (°R)	°R = °F + 460
Heat (q), Work (W), Energy (E)	ft-lb f	Joules	1.35582
	ft-lb f	Btu	0.001285
	Joules	Calories	0.2388
	Btu/h	Calories/h	252
	Kilowatts	Btu/h	3411
Power (P)	Metric horsepower	Kilowatts	0.7355
	Imperial horsepower	Kilowatts	0.7457

**Table 8: Conversion table**

## 6.5.2 Torque values

The tightening torque values for bolts and screws used in ELGi Compressors are provided in this section for reference. The tolerance for the torque values is (-) 10% from the given value.

Thread size*	Tightening torque (N-m)	Tightening torque (lb-ft)
M4	2.9	2.13
M5	5.7	4.20
M6	9.8	7.22
M8	24	17.7
M10	47	34.66
M12	81	59.73
M16	197	145.28
M20	385	283.93

**Table 9: Metric hexagonal head bolts and screws**

Thread size (inches)	Tightening torque (N-m)	Tightening torque (lb-ft)
1/4"	45	33.19
1/2"	85	62.69
3/4"	170	125.38
1"	330	243.39
1 1/4"	430	317.15
1 1/2"	510	376.15

**Table 10: BSP threads**

Thread size (inches)	Tightening torque (N-m)	Tightening torque (lb-ft)
9/16"	149	109.8875
7/8"	579	427.0125

**Table 11: UNF threads**

\* Property class of 8.8 only



Please read this document and the warranty terms accompanying the product carefully before using our product. By purchasing our product, you agree that you will assume total responsibility and risk for your use of the product. The warranty terms of the product have been provided separately.

1. ELGi is not liable for failure of the compressor ( hereinafter "compressor" or "product") to perform its obligations if such failure is as a result of Acts of God (including but not limited to fire, flood, earthquake, storm, hurricane or other natural disaster), war, invasion, act of foreign enemies, hostilities (regardless of whether war is declared), civil war, rebellion, revolution, insurrection, military or usurped power or confiscation, terrorist activities, nationalization, government sanction, blockage, embargo, labour dispute, strike, lockout or interruption or failure of electricity or telephone service and any other reasons beyond ELGi's control.
2. ELGi does not take responsibility for any damage or injury resulting from neglecting the safety instructions, warnings, cautions, precautions, or non-observance of the normal caution and care required for installation, operation, maintenance and repair of the product, even if not expressly stated, and such instances are specifically disclaimed by ELGi.
3. The entire literature including product description or any other information in this manual exclusively belongs to ELGi and is subject to copyright. No person has any right to copy, modify, distribute, transmit, display, perform, reproduce, publish, license, create derivative works, transfer or sell any information, or deal with the same in any other manner, without the knowledge and written concurrence of ELGi, violation of which would amount to infringement of rights of ELGi and would necessitate legal action.
4. The information published in this manual may include inaccuracies, or typographical errors. Changes may be periodically added to the information herein. Any changes/improvements may also be made to the products stated in this manual and ELGi is not liable if the readers are not updated with information.
5. Likewise ELGi is responsible only till the point of first sale to the ultimate customer and not thereafter and only if the product is purchased from authorized dealers of ELGi. ELGi disowns liability on account of purchase of any second hand product or purchase otherwise from unauthorized dealers. ELGi shall not be liable for any indirect, incidental, punitive, special or consequential losses or damages including any loss of profit, loss of production, loss of income or contract, loss of goodwill, expected savings or business relationships, arising out of or in any way connected with the usage of the product or information in this manual.
6. In no event ELGi shall be liable for any claims or loss having a value higher than the original purchase price of the product sold by ELGi or its network of authorised dealers.
7. These Disclaimers and the contents of this manual shall be subject to the laws of India and any disputes pertaining to this manual or anything stated therein or any product stated therein is subject to the exclusive jurisdiction of the courts in Coimbatore, Tamil Nadu, India.
8. No liability in connection with the product will accrue to ELGi,
  - If any welding or related operation involving heat is carried out in the compressor. Never weld or modify any parts including pressure vessels.
  - If any damages to the product directly or indirectly arise due to long storage (6 months) of product and subsequent corrosion of internal parts and which leads to fire or malfunctioning of the product.
  - If the compressor package and its accessories are installed in such a way to allow moisture, rain, freezing temperature or sun damage to affect the safe operation of the unit.
  - If the person who operates / maintains the compressor does not adhere to all work related safety practices and regulatory requirements.
  - If unauthorized personnel other than ELGi authorized or trained personnel carries out commissioning, installation, operation, maintenance and any repair work on the compressor.
  - If the compressor and the compressed air are used for unintended use or are misused.
  - If the compressor is operated below or in excess of its pressure and temperature limits.
  - If the compressor "ON/ OFF" switch is operated through remote control situated away from the compressor location without giving any adequate notice / alarm before starting the product .

© Copyright ELGi Equipments Limited, India 2018. All Rights Reserved.





SYMBOL	ROUGHNESS	ROUGHNESS	ROUGHNESS	ROUGHNESS	ROUGHNESS	ROUGHNESS
Δ	N1	N2	N3	N4	N5	N6
2	0.25	0.05	0.1	0.2	0.4	0.8
3	0.5	0.15	0.25	0.45	0.9	1.8
4	1.0	0.3	0.5	0.9	1.8	3.6
5	2.0	0.6	1.0	1.8	3.6	7.2
6	4.0	1.2	2.0	3.6	7.2	14.4
7	8.0	2.4	4.0	7.2	14.4	28.8
8	16.0	4.8	8.0	14.4	28.8	57.6

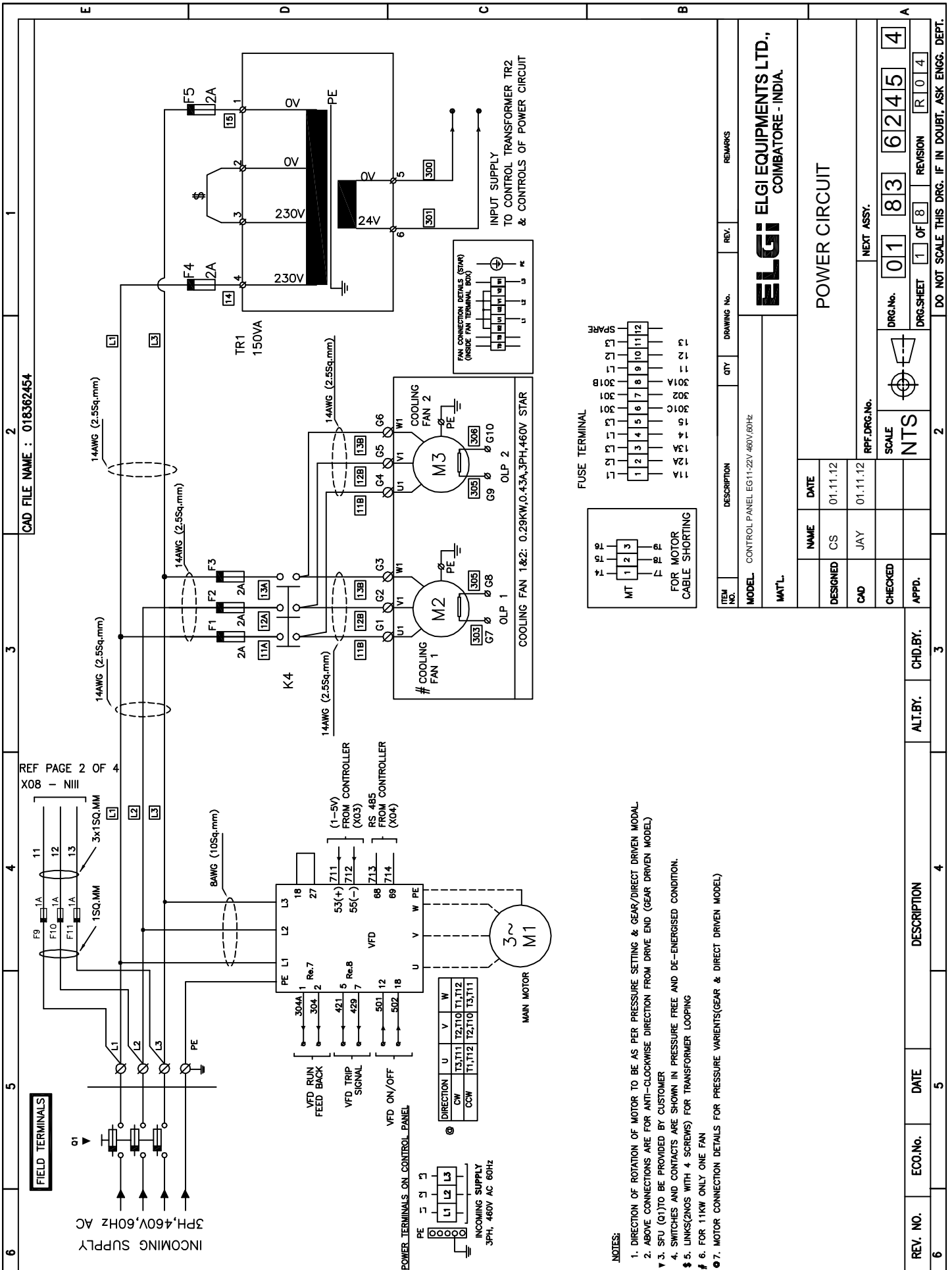

REV. NO.	ECO.No.	DATE	DESCRIPTION	ALT.BY.	CHD.BY.	APPD.	SCALE	RPF.DRG.No.	NEXT ASSY.
6					3		NTS		

**ELGI ELGI EQUIPMENTS LTD., COIMBATORE - INDIA.**

**POWER CIRCUIT**

ITEM NO.	DESCRIPTION	QTY	DRAWING No.	REV.	REMARKS
MODEL	CONTROL PANEL EG111-22V.460V.60HZ				
MAT'L					

**DESIGNED:** CS      **DATE:** 01.11.12  
**CAD:** JAY      **APPD.:** 01.11.12

**DRG.No:** 01 83 6245 4  
**DRG.SHEET:** 1 OF 8      **REVISION:** R 0 4

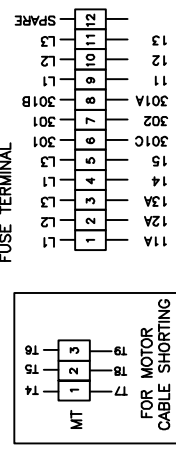

DO NOT SCALE THIS DRG. IF IN DOUBT, ASK ENGG. DEPT.

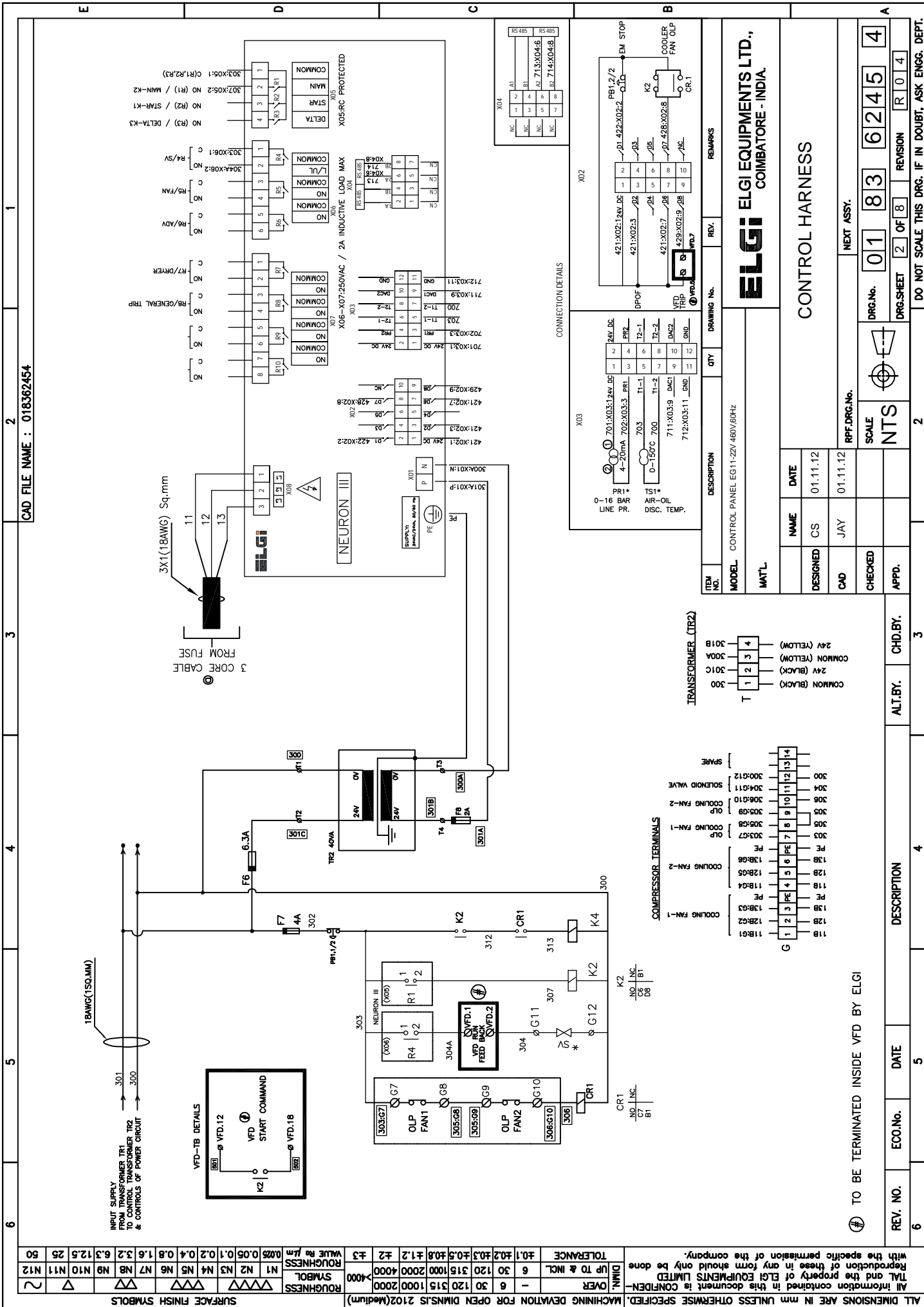

REV. NO.	ECO.No.	DATE	DESCRIPTION	ALT.BY.	CHD.BY.
6					

ITEM NO.	DESCRIPTION	QTY	DRAWING No.	REV.	REMARKS
1	CONTROL PANEL EG11-25V/460V/60HZ				
2					

REV. NO.	ECO.No.	DATE	DESCRIPTION	ALT.BY.	CHD.BY.
5					

REV. NO.	ECO.No.	DATE	DESCRIPTION	ALT.BY.	CHD.BY.
4					

REV. NO.	ECO.No.	DATE	DESCRIPTION	ALT.BY.	CHD.BY.
3					

REV. NO.	ECO.No.	DATE	DESCRIPTION	ALT.BY.	CHD.BY.
2					

REV. NO.	ECO.No.	DATE	DESCRIPTION	ALT.BY.	CHD.BY.
1					

REV. NO.	ECO.No.	DATE	DESCRIPTION	ALT.BY.	CHD.BY.
01	83	6245			

REV. NO.	ECO.No.	DATE	DESCRIPTION	ALT.BY.	CHD.BY.
01	83	6245			

REV. NO.	ECO.No.	DATE	DESCRIPTION	ALT.BY.	CHD.BY.
01	83	6245			

REV. NO.	ECO.No.	DATE	DESCRIPTION	ALT.BY.	CHD.BY.
01	83	6245			

CAD FILE NAME : 018362454

DO NOT SCALE THIS DRG. IF IN DOUBT, ASK ENGG. DEPT.

ALL DIMENSIONS ARE IN mm UNLESS OTHERWISE SPECIFIED.

TAI information contained in this document is CONFIDENTIAL and the property of ELGI EQUIPMENTS LIMITED. Reproduction of these in any form should only be done with the specific permission of the company.

SCALE NTS

DRG.No. 01 83 6245 4

DRG.SHEET 2 OF 8

REVISION R 0 4

NEXT ASSY.

CONTROL HARNESS

ELGI ELGI EQUIPMENTS LTD., COIMBATORE - INDIA.

6	5	4	3	2	1
CAD FILE NAME : 018362454					
BILL OF MATERIALS					
CODE	DESCRIPTION	MAKE	RATING	ELGI PART NO.	QTY
L1-L3	INCOMING TERMINALS	PHOENIX	RSC-6FEO WITH COVER	008932070	3
VFD	DRIVE	DANFOSS	11KW (15HP) 15KW (20HP) 18KW (25HP) 22KW (30HP)	B012000510023 B012000510024 B012000510025 B012000510019	1
K2	CONTROL CONTACTOR	SIEMENS	10A, 3RH21 31-1AB00	018362749	1
K4	FAN CONTACTOR	SIEMENS	9A, 3RT20 16-1AB01	008900130	1
CR1	CONTROL RELAY	PHOENIX	2961192	008946236	1
TR1	MULTI TAP TRANSFORMER	PLITRON	150VA 0-0-230-230V/0-24V	00893703A	1
TR2	CONTROL TRANSFORMER	BASIC ELECTRICAL	40VA,0-24/0-24V	00893703C	1
G,T	CONNECTING TERMINALS	WAGO	281-101	018362734	18
PE	CONNECTING TERMINALS (Y/G)	WAGO	281-107	018362736	2
MT	MOTOR CONNECTING TERMINALS	CONNECTWELL	CTS10U	008946220	3
F	FUSE TERMINALS WITH GLASS FUSE	WAGO	281-611	018362735	12
-	GLASS FUSE	PROTECTOR	1A, SLOW BLOW	00894641A	-
-	GLASS FUSE	PROTECTOR	2A, SLOW BLOW	00894642A	-
-	GLASS FUSE	PROTECTOR	4A, SLOW BLOW	00894644A	-
-	GLASS FUSE	PROTECTOR	6.3A, SLOW BLOW	00894646A	-
N III	NEURON CONTROLLER	ELGI	-	X0180912	1
E-STOP	EMERGENCY STOP PUSH BUTTON	TEKNIC	P2AML4	008940030	1
PE	EARTH STRIP FOR COMPONENT EARTH WITH 5mm SCREW WITH FLAT & SPRING WASHER	-	COPPER WITH TIN COATING	-	1
CONNECTER	PLC CONNECTER SET	WAGO	231-102/026-000 713-1105 713-1106 713-1104 231-204/026-000 231-206/026-000 231-203/026-000 231-108/026-000	018400109	1 SET
PS1	PRESSURE TRANSMITTER	DANOSS	-	00897902N	1
TS1	TEMPERATURE SENSOR	DANOSS	PT1000	018400078	1

ITEM NO.	DESCRIPTION	QTY	DRAWING No.	REV.	REMARKS
MODEL	CONTROL PANEL EG11-22V,460V,60HZ				
MAT'L					
DESIGNED	NAME	DATE	NEXT ASSY.		
CAD	CS	01.11.12	DRG.No.	01	83
CHECKED	JAY	01.11.12	DRG.SHEET	3	OF 8
APPD.			REVISION	R	0
					4



BILL OF MATERIALS

SCALE	NTS	RPF.DRG.No.	
CHECKED			
APPD.			
CHD.BY.			
ALT.BY.			
DESCRIPTION			
DATE			
ECO.No.			
REV. NO.			

ALL DIMENSIONS ARE IN mm UNLESS OTHERWISE SPECIFIED. MACHINING DEVIATION FOR OPEN DIMS. IS 2102(Medium) SURFACE FINISH SYMBOLS

ROUGHNESS SYMBOL	ROUGHNESS VALUE IN μm
N1	0.05
N2	0.1
N3	0.2
N4	0.4
N5	0.8
N6	1.6
N7	3.2
N8	6.3
N9	12.5
N10	25
N11	50
N12	100

DIM/ OVER TOLERANCE  
 6 30 120 315 1000 2000 4000  
 ±0.1 ±0.2 ±0.3 ±0.5 ±0.8 ±1.2 ±2 ±3  
 >4000

All information contained in this document is CONFIDENTIAL and the property of ELGI EQUIPMENTS LIMITED. Reproduction of these in any form should only be done with the specific permission of the company.

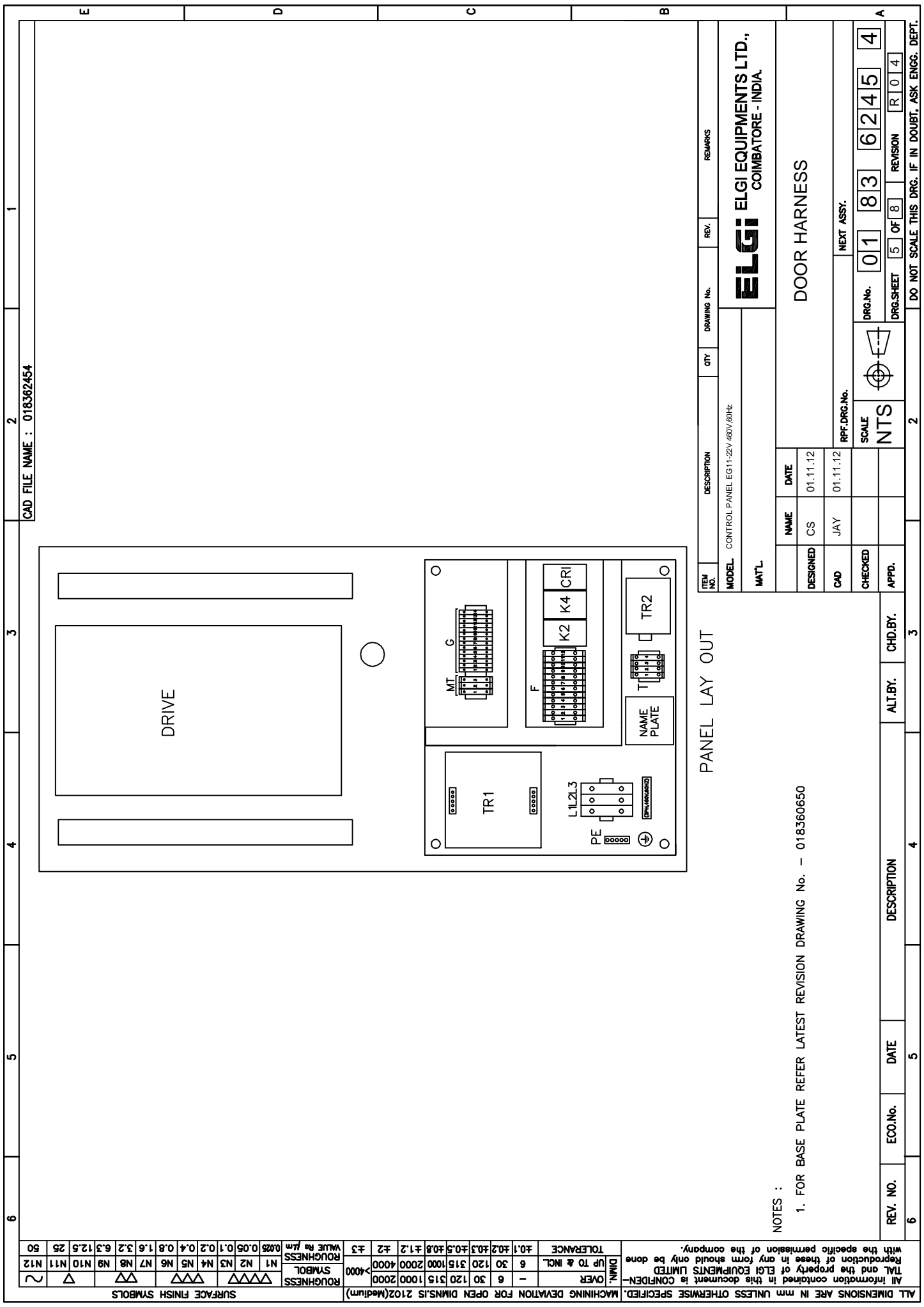

CAD FILE NAME : 018362454

PANEL LAY OUT

ITEM NO.	DESCRIPTION	QTY	DRAWING No.	REV.	REMARKS			
MODEL	CONTROL PANEL EG111-22V.460V.60HZ							
MAT'L								
DESIGNED	NAME	DATE	<b>ELGI</b> ELGI EQUIPMENTS LTD., COIMBATORE - INDIA.  DOOR HARNESS					
CAD	CS	01.11.12						
CHECKED	JAY	01.11.12						
APPD.			DRG.No.	01	83	6245	4	
			DRG.SHEET	5	OF	8	REVISION	R 0 4
			RPF.DRG.No.				NEXT ASSY.	
			SCALE	NTS				

NOTES :  
 1. FOR BASE PLATE REFER LATEST REVISION DRAWING No. - 018360650

REV. NO.	ECO.No.	DATE	DESCRIPTION	ALT.BY.	CHD.BY.
6		5			3

MACHINING DEVIATION FOR OPEN DIMS. S 2102 (Medium)		±3	±2	±1.2	±1.2	±0.8	±0.8	±0.5	±0.3	±0.2	±0.1
SURFACE FINISH SYMBOLS		>4000	2000	1000	1000	2000	4000	1000	315	120	60
ROUGHNESS SYMBOL		▽▽▽	▽▽	▽	▽	▽	▽	▽	▽	▽	▽
ROUGHNESS VALUE IN μm		0.025	0.05	0.1	0.2	0.4	0.8	1.6	3.2	6.3	12.5
TOLERANCE		OVER	-	6	30	120	315	1000	2000	4000	10000
DIM. TYP.		OVER	-	6	30	120	315	1000	2000	4000	10000
UP TO & INCL.		6	30	120	315	1000	2000	4000	10000	20000	40000
TOLERANCE		±0.1	±0.2	±0.3	±0.5	±0.8	±1.2	±2	±3	±4	±6

ALL DIMENSIONS ARE IN mm UNLESS OTHERWISE SPECIFIED.  
 Reproduction of these in any form should only be done with the specific permission of the company.  
 T&I and the property of ELGI EQUIPMENTS LIMITED  
 ALL information contained in this document is CONFIDENTIAL

