

Operator and Parts Manual

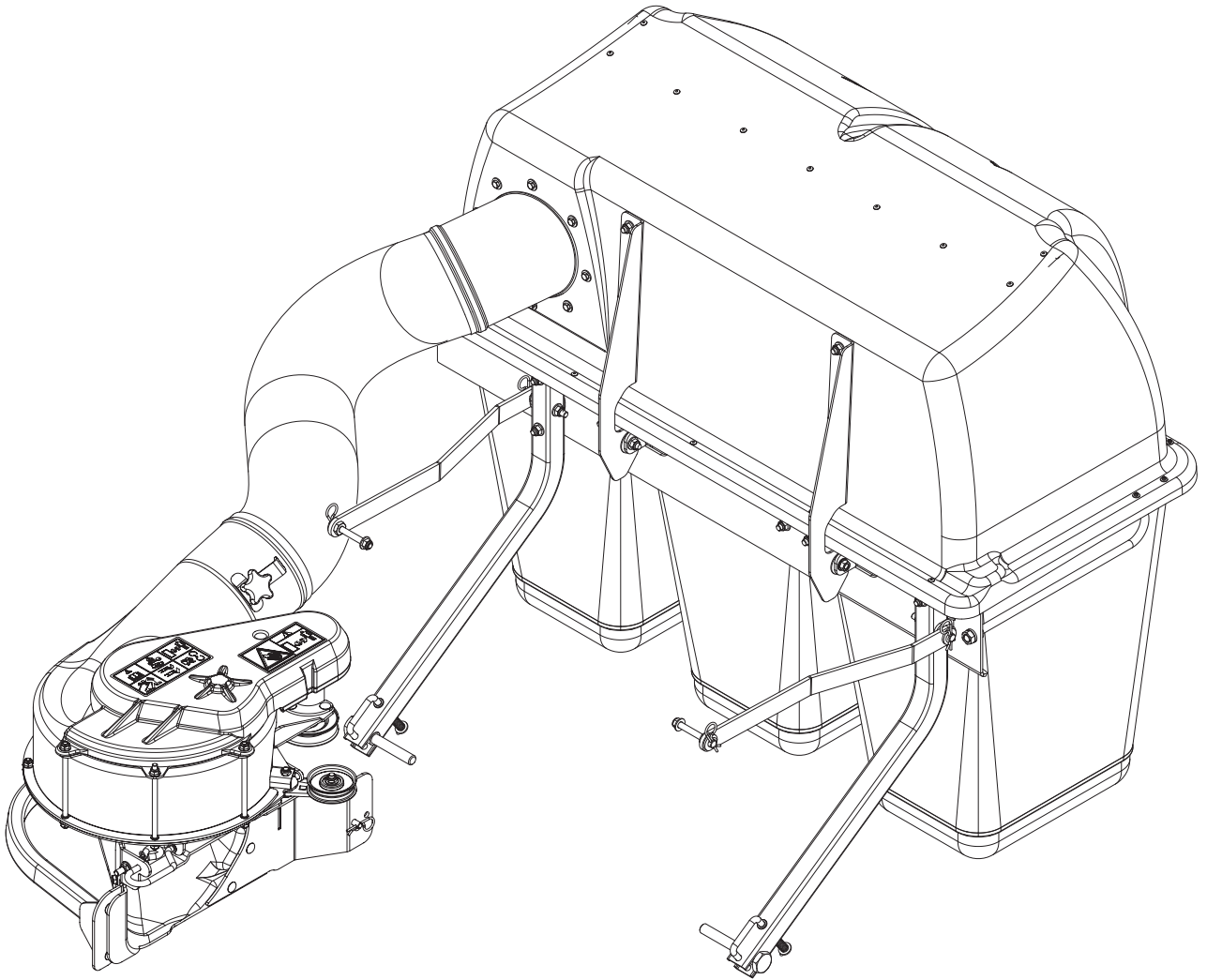

Collection System
966406901



CAUTION

BEFORE ASSEMBLING GRASS CATCHER TO MOWER

- **Set parking brake.**
- **Place motion control levers in “NEUTRAL” position.**
- **Turn ignition key “OFF” and remove key.**
- **Make sure the blades and all moving parts have completely stopped.**
- **Disconnect spark plug and place wire where it cannot come in contact with plug.**

CONTENTS

SAFETY RULES	4
GENERAL OPERATION	4
SLOPE OPERATION	4
CHILDREN.....	5
SERVICE.....	5
ASSEMBLY	6
OPERATION	11
TIPS FOR IMPROVED BAGGING.....	11
GENERAL RECOMMENDATIONS.....	11
STORAGE.....	11
REPAIR PARTS	12

CONGRATULATIONS on the purchase of a new collection system. It has been designed, engineered and manufactured to give you the best possible dependability and performance.

Should you experience any problem you cannot easily remedy, please contact your nearest authorized service center/ department. They have competent, well-trained technicians and the proper tools for service and repairs.

Please read and retain this manual. The instructions will enable you to assemble and maintain your collection system properly. Always observe the "SAFETY RULES".

KNOW YOUR BLOWER SYSTEM

READ THIS OPERATION MANUAL AND SAFETY RULES BEFORE ASSEMBLING OR OPERATING YOUR BLOWER SYSTEM. Compare the illustrations with the carton contents to familiarize yourself with the parts before starting the assembly. Study the operating instructions and safety precautions thoroughly to insure proper functioning of your Grass Catcher and to prevent injury to yourself and others. Save this manual for future reference.



WARNING!

Engine exhaust, some of its constituents, and certain vehicle components contain or emit chemicals known to the State of California to cause cancer and birth defects or other reproductive harm.



The operation of any mower can result in foreign objects thrown into the eyes, which can result in severe eye damage. ALWAYS wear safety glasses or eye shields before starting your mower and while mowing. Standard safety glasses are recommended or a wide vision safety mask for over spectacles.

SAFETY RULES



SAFE OPERATION PRACTICES FOR RIDE-ON MOWERS



DANGER!

THIS CUTTING MACHINE IS CAPABLE OF AMPUTATING HANDS AND FEET AND THROWING OBJECTS. FAILURE TO OBSERVE THE FOLLOWING SAFETY INSTRUCTIONS COULD RESULT IN SERIOUS INJURY OR DEATH.

GENERAL OPERATION

- Read, understand and follow all instructions in the manual and on the machine before starting.
- Only allow responsible adults, who are familiar with the instructions, to operate the machine.
- Clear the area of objects such as rocks, stones, toys, wire etc., which could be picked up and thrown by the blades.
- Be sure the area is clear of all people and pets before mowing. Stop the machine if anyone enters the area.
- Never carry passengers or children even with blades off.
- Do not mow in reverse unless absolutely necessary. Always look down and behind before and while backing.
- Be aware of the mower discharge direction and do not direct it towards anyone. Do not operate the mower without either the entire grass catcher or the guard in place.
- Slow down before turning.
- Never leave the machine unattended when the engine is running. Always turn off the blades, set the parking brake, stop the engine and remove the key before leaving the machine.
- Turn off blades when not mowing.
- Stop engine before removing grass catcher or unclogging chute.
- Mow only in daylight or good artificial light.
- Do not operate the machine while under the influence of alcohol or drugs.
- Watch out for traffic when operating near or crossing roadways.
- Use extra care when loading and unloading the machine onto a trailer or truck.
- Data indicates that operators, age 60 years and above, are involved in a large percentage of riding mower-related injuries. These operators should evaluate their ability to operate the riding mower safely enough to protect themselves and others from serious injury.

- If front weights are included in the collection system, **DO NOT** operate mower with the grass catcher unless the weights are installed.
- Keep machine free of grass, leaves or other debris buildup which can touch hot exhaust/engine parts and burn. Do not allow the mower deck to plow leaves or other debris which can cause buildup to occur. Clean any oil or fuel spillage before operating or storing the machine. Allow machine to cool before storage.

SLOPE OPERATION

Slopes are a major factor related to loss-of-control and tip-over accidents, which can result in severe injury or death. All slopes require extra caution. If you cannot back up the slope or if you feel uneasy on it, do not mow it.

DO

- Mow up and down slopes (10° Max.), not across.
- Remove obstacles such as rocks, tree limbs, etc.
- Watch for holes, ruts, or bumps. Uneven terrain could overturn the machine. **Tall grass can hide obstacles.**
- Use slow speed. Choose a low speed so that you will not have to stop while on the slope.
- Use extra care with grass catchers or other attachments. These can change the stability of the machine.
- Keep all movement on the slopes **slow** and **gradual**. Do not make sudden changes in speed or direction.
- Avoid starting or stopping on a slope. If tires lose traction, disengage the blades and proceed slowly **straight** down the slope.

DO NOT

- **Do not** turn on slopes unless necessary, and then, turn slowly and gradually downhill, if possible.
- **Do not** mow near drop-off, ditches, or embankments. The mower could suddenly turn over if a wheel is over the edge of a cliff or ditch, or if an edge caves in.

SAFETY RULES



SAFE OPERATION PRACTICES FOR RIDE-ON MOWERS



- **Do not** mow on wet grass. Reduced traction could cause sliding.
- **Do not** try to stabilize the machine by putting your foot on the ground.

CHILDREN

Tragic accidents can occur if the operator is not alert to the presence of children. Children are often attracted to the machine and the mowing activity. Never assume that children will remain where you last saw them.

- **NEVER allow children to operate the machine.**
- Keep children out of the mowing area and under the watchful care of another responsible adult.
- Be alert and turn off the machine if children enter the area.
- Before and when backing, look behind and **down** for small children.
- Never carry children. They may fall off and be seriously injured or interfere with safe machine operation.
- Use extra care when approaching blind corners, shrubs, trees, or other objects that may obscure vision.

SERVICE

- The operation of any mower can result in foreign objects thrown into the eyes, which can result in severe eye damage. Always wear safety glasses or eye shields while operating your mower or performing any adjustments or repairs. We recommend a wide vision safety mask over spectacles or standard safety glasses.
- Use extra care in handling gasoline and other fuels. They are flammable and vapors are explosive.
 - Use only an approved container.
 - Never remove gas cap or add fuel with the engine running.
 - Allow engine to cool before refueling.
 - Do not smoke.
 - Never refuel the machine indoors.
 - Never store the machine or fuel container inside where there is an open flame, such as a water heater.

- Never run a machine inside a closed area.
- Keep nuts and bolts, especially blade attachment bolts, tight and keep equipment in good condition.
- Never tamper with safety devices. Check regularly for proper operation.
- Keep machine free of grass, leaves, or other debris buildup. Clean oil or fuel spillage. Allow machine to cool before storing.
- Stop and inspect the equipment if you strike an object. Repair, if necessary, before restarting.
- Never make adjustments or repairs with the engine running.
- Grass catcher components are subject to wear, damage, and deterioration, which could expose moving parts or allow objects to be thrown. Frequently check components and replace with manufacturer's recommended parts, when necessary.
- Mower blades are sharp and can cut. Wrap the blade(s) or wear gloves, and use extra caution when servicing them.
- Check brake operation frequently. Adjust and service as shown in the Operator's Manual.



WARNING!

Battery posts, terminals and related accessories contain lead and lead compounds, chemicals known to the State of California to cause cancer and birth defects or other reproductive harm. Wash hands after handling.



CAUTION

In order to prevent accidental starting when setting up, transporting, adjusting or making repairs, always disconnect spark plug wire and place wire where it cannot contact spark plug.

ASSEMBLY

TOOLS REQUIRED

Wrench $\frac{5}{16}$ " (2)	Wrench $1\frac{1}{4}$ " (1)
Wrench $\frac{3}{4}$ " (1)	Wrench $\frac{9}{16}$ " (2)
Wrench $\frac{1}{2}$ " (1)	Wrench $\frac{7}{16}$ "
Breaker bar with $\frac{15}{16}$ " socket	
Screwdriver, standard (1)	
Torque wrench	
Socket $\frac{1}{2}$ "	
Ratchet with $\frac{3}{8}$ " drive, 6" extension	

NOTE: When right hand (RH) and left hand (LH) are mentioned in this manual, it means when you are seated on the mower in the operator's position.

1 INSTALLING BLOW OUT BAFFLES

NOTE: The collection system includes optional deck baffling designed to help prevent blow out when collecting in extremely dry cutting conditions. If cutting conditions are not extremely dry, baffling may not be required.

1. Remove hardware from deck's center baffle.
2. Place the left hand baffle from the kit between the deck skirt and the front edge of deck.
3. Secure the left hand baffle and the center baffle to the deck skirt with four 1" carriage bolts and nuts supplied with the kit, using a $\frac{7}{16}$ " wrench.
4. With a $\frac{1}{2}$ " wrench, install the right hand baffle on blade side of deck skirt and secure with two $\frac{1}{2}$ " carriage bolts and nuts from the kit.

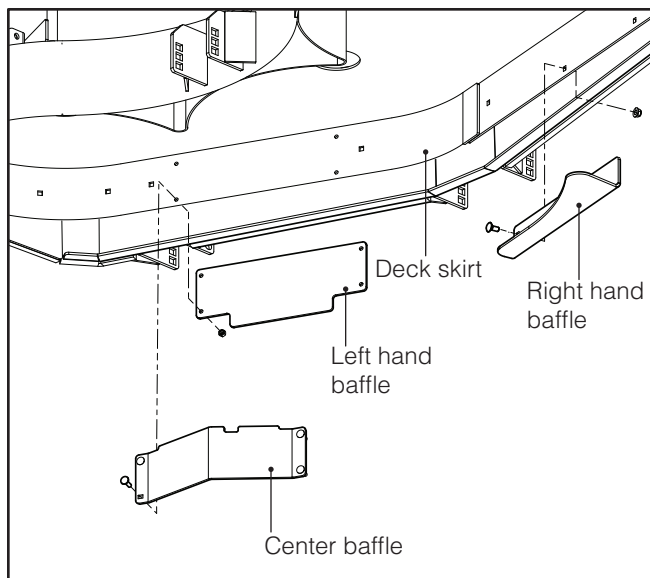

2 INSTALLING BLADES



WARNING!
Blades are sharp. Protect your hands with gloves and/or wrap blades with a heavy cloth when handling.

1. Remove the original deck blades with a breaker bar and $\frac{15}{16}$ " socket. Retain the blade bolts for reuse.
2. Install the kit blades using the existing blade bolts (torque to 90 ft./lbs.).
3. Rotate the blades by hand and check for clearance of all baffles.
4. Make sure all hardware is tight.

ASSEMBLY

3 INSTALLING DRIVE PULLEY

1. Using two $\frac{9}{16}$ " wrenches, remove the hardware and discharge chute from the deck. (Deck configuration will vary by size.)
2. Lower deck to the lowest cutting position.
3. With a $\frac{1}{2}$ " wrench, remove the hardware of the right hand (discharge side) belt cover and remove the shield from the deck.

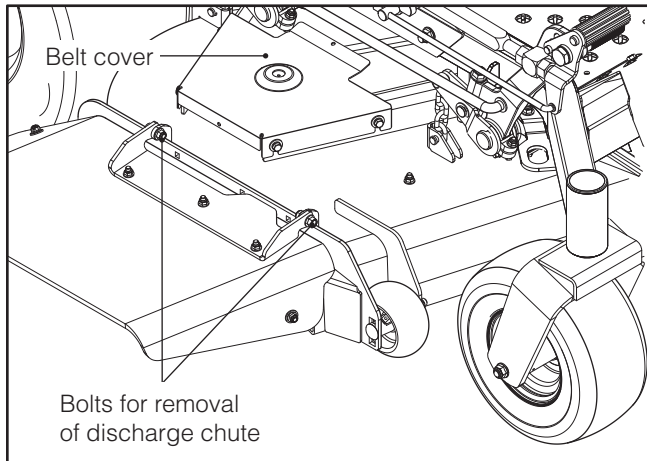

4. Relieve the tension from the deck belt and remove it from the center deck pulley. (See Operator's Manual if necessary)
5. Remove the bolts and washers securing the right hand deck pulley to the spindle with a $\frac{1}{2}$ " wrench. Do not remove the pulley.
6. Install new drive pulley on top of the current deck pulley, placing spacers in between. Use a $\frac{1}{2}$ " wrench to secure the three $2\frac{1}{2}$ " bolts and spring washers to the top of the pulley. See illustration.
7. Reinstall the deck belt.

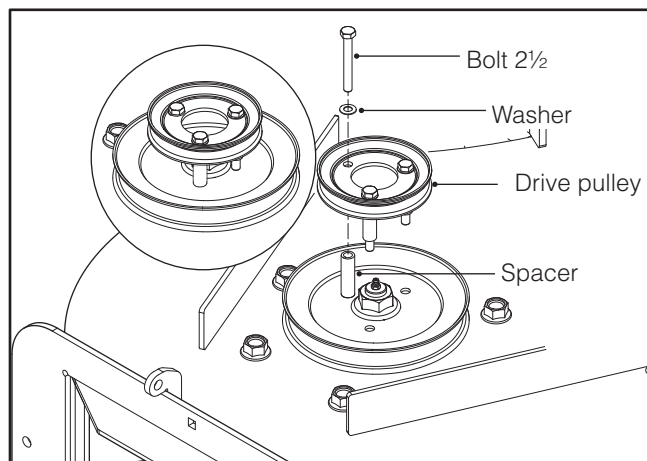

4 MOUNTING BLOWER ASSEMBLY

1. At the rear of the blower, remove the mount pin and retainer that are connected to the blower by the lanyard.

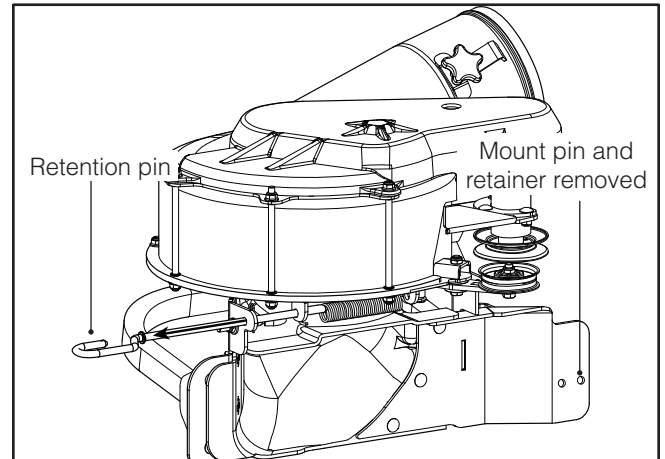

2. Slide the retention pin towards the front of the blower and set the blower on the deck. The deck's discharge mounting tabs will fit between the mount brackets on the blower.

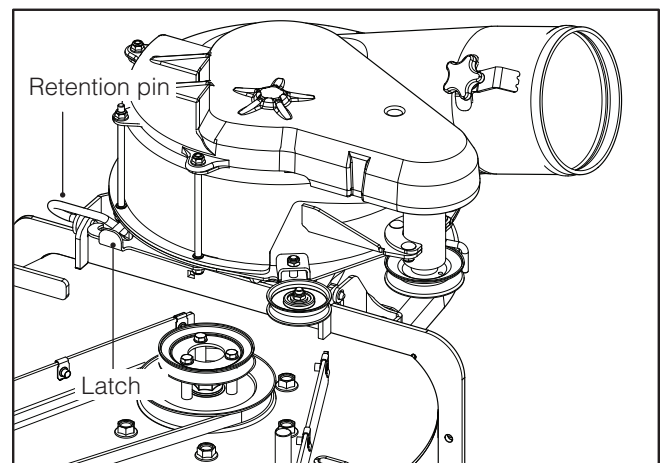

3. Slide the retention pin back towards the rear of the blower, assuring it passes through the discharge mounting tabs on the deck.
4. Rotate the latch to hook over the retention pin.
5. Place mount pin (removed in step 3) through hole in rear blower mount and deck. Secure mount pin with retainer.

ASSEMBLY

5 INSTALLING DRIVE BELT

1. Install drive belt around pulley on blower.
2. Rotate belt keeper within $\frac{1}{8}$ " of blower pulley and tighten with $\frac{1}{2}$ " wrench.
3. Rotate blower idler towards front of blower and place belt over deck pulley. Use a breaker bar in the idler opening if necessary. See illustration for correct belt routing.

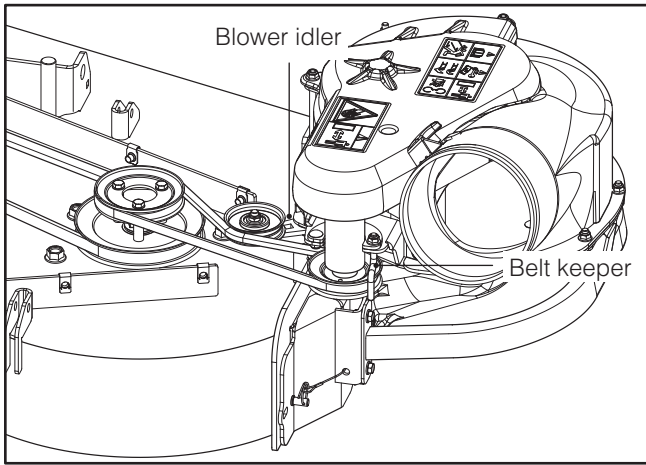

4. Set drive kit deck belt cover over deck pulleys and secure with knobs.

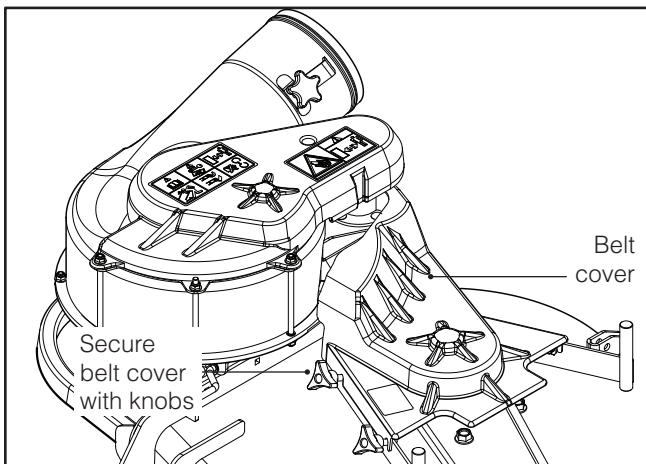

6 INSTALLING COLLECTOR

1. Using two $\frac{15}{16}$ " wrenches, remove the lower ROPS bolts on each side, retaining washer and nut for next step.

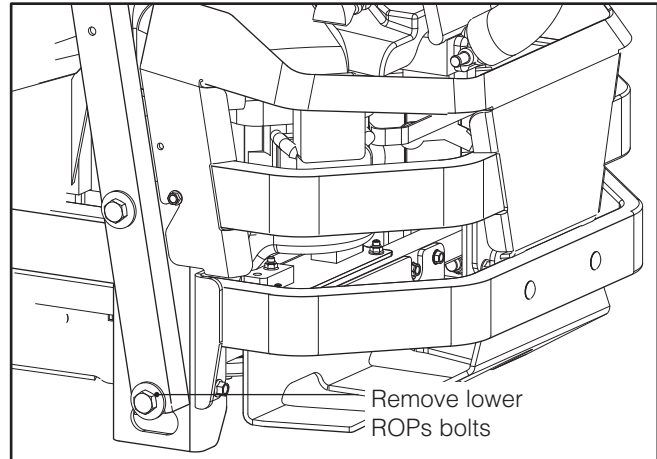

2. Install a hitch pin, washer and nut on each side where the ROPS bolt was removed. Tighten hitch pins and nuts with $\frac{15}{16}$ " and $1\frac{1}{4}$ " wrenches.
3. Install the mount pins through ROPS tube in predrilled holes approximately 18" up from bottom of ROPS tube. The pin will pass from the outside in, so the threads are on the inside of the tube. Secure each side with nuts and tighten using $\frac{3}{4}$ " and $\frac{9}{16}$ " wrenches.

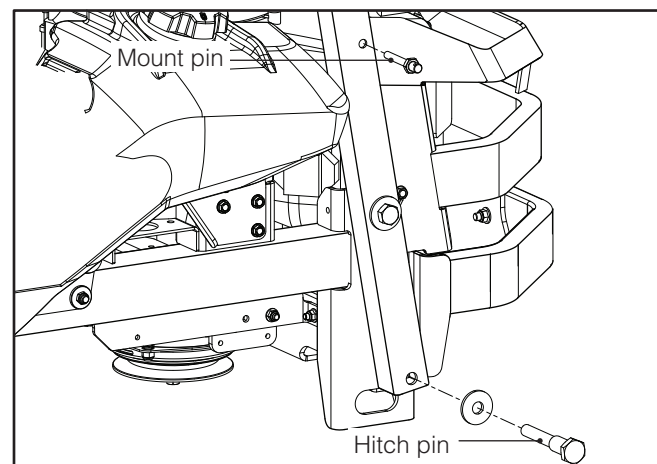

ASSEMBLY

- Attach the hitch tubes to the hitch assembly with 2¼" bolts and nuts as shown. Tighten using 9/16" and ¾" wrenches. Install pin mounts through the hitch tubes and hitch assembly and secure with nuts.

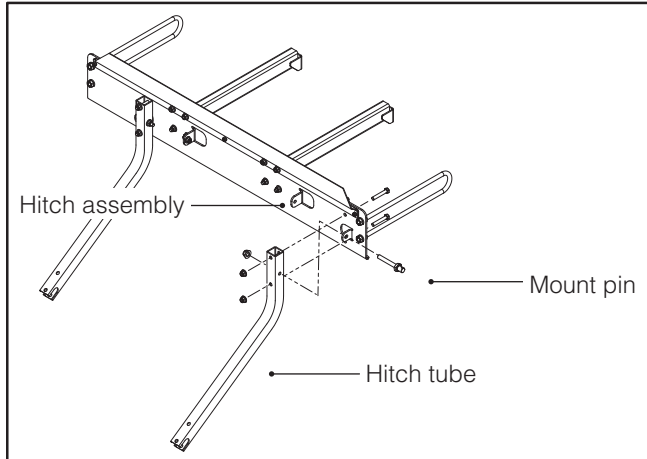

- Attach the straps to the previously installed mount pins at the hood assembly.
NOTE: the short leg of the straps attach at the cross plate end and the straps angle inward.
- Secure the straps with washers and retainers in the mount pins.

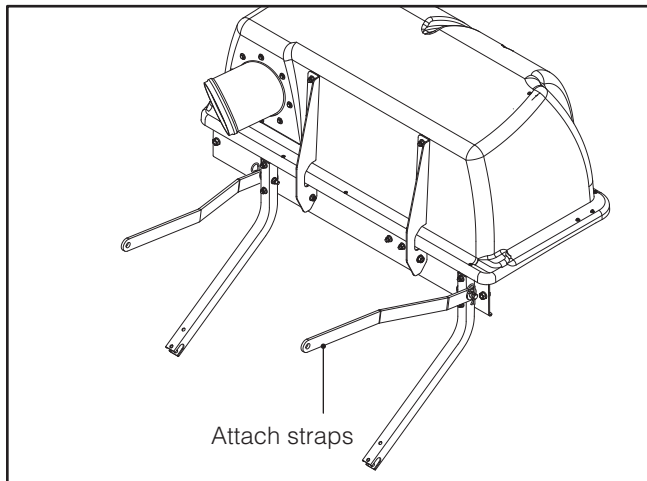

- With the hood/hitch assembly behind the mower, place the lower slotted portion of the hitch tubes over the hitch pins attached to the bottom of the ROPS.
NOTE: be sure that the retention pin hooks over the front of the hitch pins.
- Lift up on the rear of the hood and attach the free ends of the straps on the upper pins installed in the ROPS. Secure with washers and retainers.

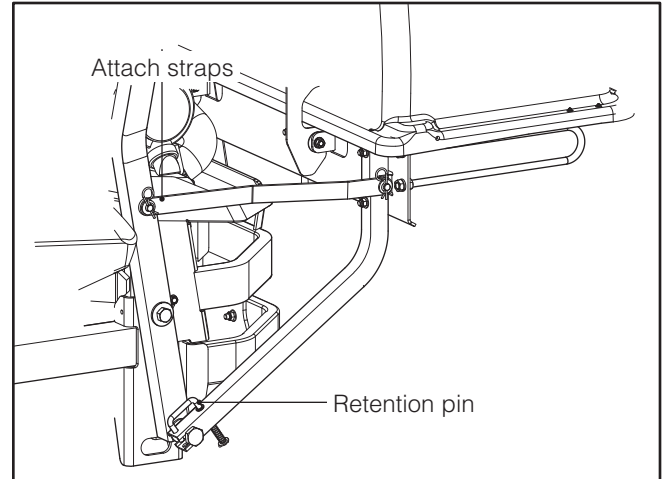

- Release the hood latches of the hood and lift hood open. If hood does not stay open, tighten hood hinge bolts slightly.
- Install bags, close and latch hood.

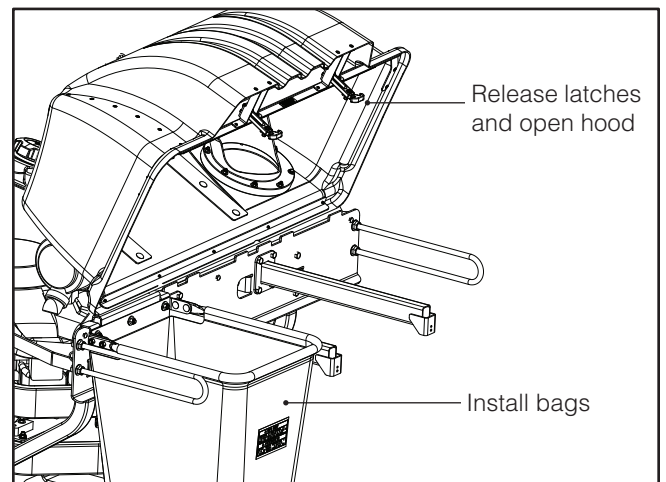

ASSEMBLY

11. Attach the hose to the hood assembly and secure with hose clamp.
12. Loosen the retention knob on the outlet end of the blower.
13. Slide hose over the blower outlet and against the base of the retention bracket.
14. Rotate the retention bracket so it catches between the ribs on the hose and tighten the knob.

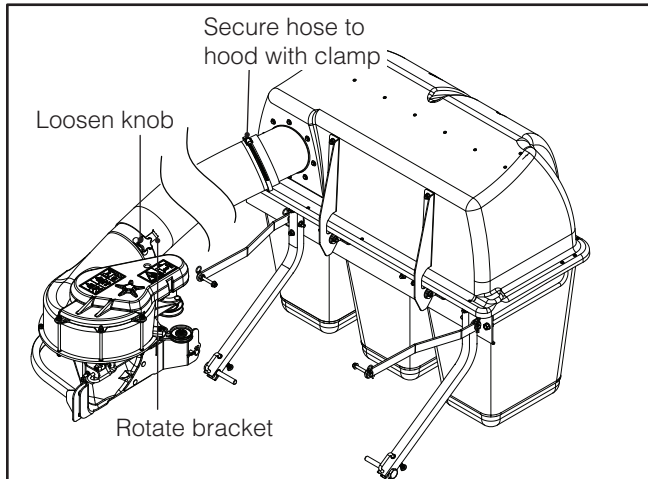

CAUTION

- **DO NOT** operate mower with grass catcher partially installed.
- **Disengage blades and stop engine before leaving mower seat to empty containers, unclogging chutes, etc.**
- **Close cover before starting.**
- **Disengage mower blades when crossing driveways or gravel surfaces and other areas where thrown objects could be a hazard.**
- **DO NOT** attempt to vacuum cans or other potentially hazardous projectiles.

OPERATION

TIPS FOR IMPROVED BAGGING

Follow the mower operation instructions in the mower operator's manual.

When operating your grass catcher on a lawn where grass and leaf bagging equipment has not been used, you are picking up thatch and debris that has accumulated for long periods of time. The amount collected and the total time of operation may be greater than you will experience with regular use of your grass catcher.

- Always run throttle at full speed when bagging.
- Select a speed low enough to give good mower cutting performance, good quality cut and good bagging performance.

NOTE: It may be necessary to overlap width of cut to suit your conditions.

- If grass is extremely tall, it should be mowed twice. The first time relatively high, the second time to desired height.
- Use left hand side of mower for trimming.
- Frequently clean the hood debris screen. (Located inside the rear of the hood). A clogged screen results in poor ventilation and may cause plugging.
- Avoid cutting wet grass or in the morning while the dew is still heavy. Grass clippings collected under these conditions tend to be sticky and adhere to the walls of the flow path causing clogging.
- If the grass catcher fails to pick up cut grass or leaves, it is an indication that clogging has occurred in the system or that the grass catcher containers are full.
 - a. Disengage blades, place motion control levers in neutral position.
 - Unlatch and raise cover.
 - Slide out containers and dispose of clippings.
 - Replace containers, close cover, and latch.
 - b. Unlatch chutes and check for clogging.
 - Remove all debris in chute.
 - Reassemble and latch chutes.

GENERAL RECOMMENDATIONS

Always observe safety rules when performing any maintenance.

- Before each use check for loose fasteners.
- Clean unit thoroughly after each use.

BLADE CARE

- For best results mower blades must be kept sharp. Replace bent or damaged blades.
- See BLADE CARE instructions in your mower operator's manual.

STORAGE

When grass catcher is to be stored for a period of time, clean it thoroughly, remove all dirt, grass, leaves, etc. Store in a clean, dry place.



CAUTION

Do not leave grass in bagger containers. Empty containers after each use and before storing. Failure to do so may result in spontaneous combustion which could develop into a fire.



CAUTION

Grass catcher components are subject to wear, damage and deterioration, which could expose moving parts or allow objects to be thrown. Frequently check components and replace with manufacturer's recommended parts, when necessary.

