

# TECHNICAL MANUAL

## **\*PC 14 SEER R-410A Package Air Conditioners with R-410A**

- Refer to Service Manual RS6300011 (Horizontal) for installation, operation, and troubleshooting information.
- All safety information must be followed as provided in the Service Manual.
- Refer to the appropriate Parts Catalog for part number information.
- Models listed on page 3.

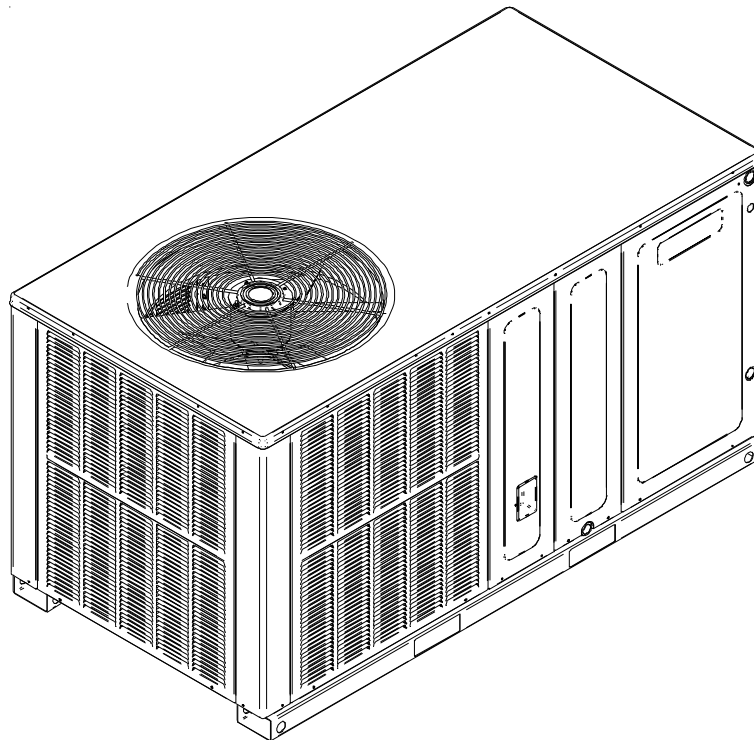

This manual is to be used by qualified, professionally trained HVAC technicians only. Goodman does not assume any responsibility for property damage or personal injury due to improper service procedures or services performed by an unqualified person.

RT6322007r10  
October 2013

# PRODUCT IDENTIFICATION

The model and manufacturing number are used for positive identification of component parts used in manufacturing. Please use these numbers when requesting service or parts information.

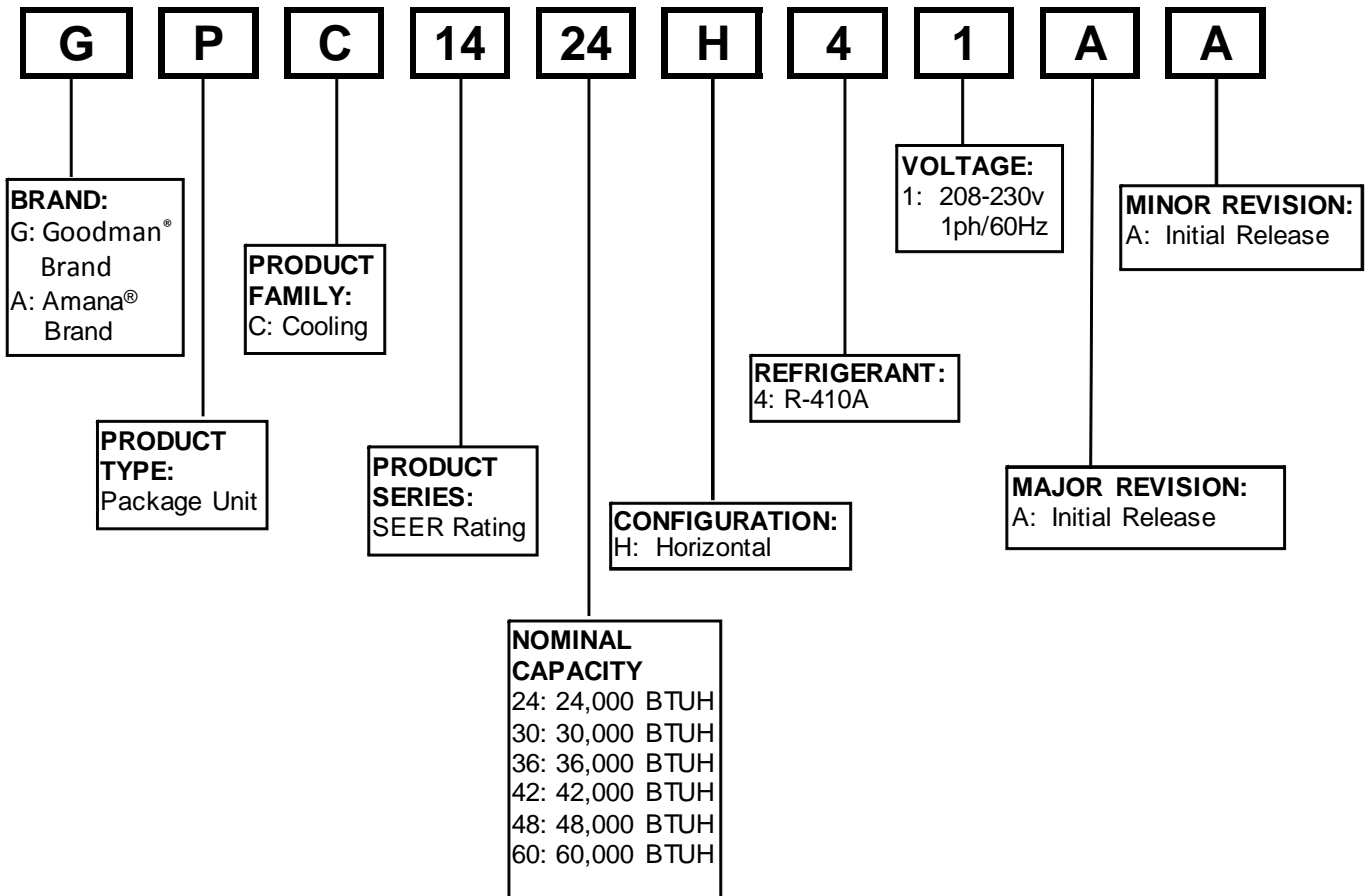

**WARNING**

**HIGH VOLTAGE!**

Disconnect ALL power before servicing or installing this unit. Multiple power sources may be present. Failure to do so may cause property damage, personal injury or death.

**WARNING**

Goodman will not be responsible for any injury or property damage arising from improper service or service procedures. If you install or perform service on this unit, you assume responsibility for any personal injury or property damage which may result. Many jurisdictions require a license to install or service heating and air conditioning equipment.

**WARNING**

Installation and repair of this unit should be performed **ONLY** by individuals meeting (at a minimum) the requirements of an "entry level technician" as specified by the Air-Conditioning, Heating, and Refrigeration Institute (AHRI). Attempting to install or repair this unit without such background may result in product damage, personal injury or death.

# PRODUCT IDENTIFICATION

The model and manufacturing number are used for positive identification of component parts used in manufacturing. Please use these numbers when requesting service or parts information.

GPC1424H41AA  
GPC1430H41AA  
GPC1436H41AA  
GPC1442H41AA  
GPC1448H41AA  
GPC1460H41AA

**5mm**  
*model specific*  
*5 mm information*  
*begins on page 29.*

 **WARNING**

The United States Environmental Protection Agency (“EPA”) has issued various regulations regarding the introduction and disposal of refrigerants introduced into this unit. Failure to follow these regulations may harm the environment and can lead to the imposition of substantial fines. These regulations may vary by jurisdiction. Should questions arise, contact your local EPA office.

 **WARNING**

Do not connect or use any device that is not design certified by Goodman for use with this unit. Serious property damage, personal injury, reduced unit performance and/or hazardous conditions may result from the use of such non-approved devices.

 **WARNING**

To prevent the risk of property damage, personal injury, or death, do not store combustible materials or use gasoline or other flammable liquids or vapors in the vicinity of this appliance.

# PRODUCT DESIGN

\*PC14 Package Cooling Units are designed for outdoor installations only in either residential or light commercial applications.

The connecting ductwork (Supply and Return) can be connected for either horizontal or vertical airflow. In the vertical application a matching Roof Curb is recommended.

A return air filter must be installed behind the return air grille(s) or provision must be made for a filter in an accessible location within the return air duct. The minimum filter area should not be less than those sizes listed in the Specification Section. Under no circumstances should the unit be operated without return air filters.

A 3/4" PVC pipe is provided for removal of condensate water from the indoor coil. In order to provide proper condensate flow, a drain trap is supplied and shipped loose inside the unit for field installation. (Do not reduce the drain line size.)

Refrigerant flow control is achieved by use of restrictor orifices. \*PC14 units use the FasTest Access Fitting System with a saddle that is either soldered to the suction and liquid lines or is fastened with a locking nut to the access fitting box (core) and then screwed into the saddle. **Do not remove the core from the saddle until the refrigerant charge has been removed. Failure to do so could result in property damage or personal injury.**

The single phase units use permanent split capacitor (PSC) design compressors. Starting components are therefore not required for these units. A low microfarad run capacitor assists the compressor to start and remains in the circuit during operation.

All \*PC14 units have EEM indoor blower motors that are energized by a 24V signal from the thermostat and are constant torque motors with very low power consumption. The EEM features an integral control module.

Air for condensing (cooling cycle) is drawn through the outdoor coil by a propeller fan, and is discharged vertically out the top of the unit. The outdoor coil is designed for .0 static. No additional restriction (ductwork) shall be applied.

Conditioned air is drawn through the filter(s), field installed, across the coil and back into the conditioned space by the indoor blower.

\*PC1424-30H41\* use Copeland Reciprocating Compressors.  
\*PC1436-60H41\* use Copeland Scroll Compressors. There are a number of design characteristics which are different from the traditional reciprocating compressor.

- Due to their design Scroll Compressors are inherently more tolerant of liquid refrigerant. **NOTE:** Even though the compressor section of a Scroll compressor is more tolerant of liquid refrigerant, continued floodback or flooded start conditions may wash oil from the bearing surfaces causing premature bearing failure.
- Scroll Compressors use white oil which is compatible with 3GS oil which may be used if additional oil is required.
- Operating pressures and amp draws may differ from standard reciprocating compressors. This information may be found in the "Cooling Performance Data" section.

## Location and Clearances

**NOTE:** To ensure proper condensate drainage, unit must be installed in a level position.

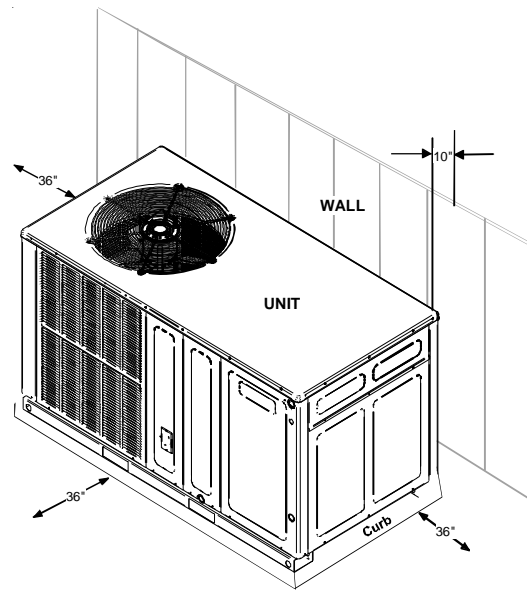

## Outside Slab Installation - Horizontal (H)

Minimum clearances are required to avoid air recirculation and keep the unit operating at peak efficiency.

# PRODUCT DESIGN

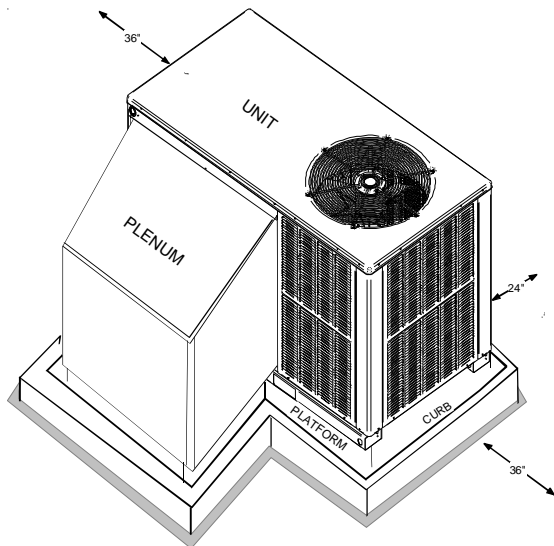

**Rooftop Installation - Horizontal (H)**

In installations where the unit is installed above ground level and not serviceable from the ground (Example: Roof Top installations), the installer must provide service platform for service person with rails or guards in accordance with local codes or ordinances or in their absence with the latest edition of the Uniform Mechanical Code Section 305.

**NOTE:** Unit can also use roof curb.

 <b>WARNING</b>
<b>TO PREVENT POSSIBLE PROPERTY DAMAGE, THE UNIT SHOULD REMAIN IN AN UPRIGHT POSITION DURING ALL RIGGING AND MOVING OPERATIONS. TO FACILITATE LIFTING AND MOVING IF A CRANE IS USED, PLACE THE UNIT IN AN ADEQUATE CABLE SLING.</b>

Refer to Roof Curb Installation Instructions for proper curb installation. Curbing must be installed in compliance with the National Roofing Contractors Association Manual.

# PRODUCT DIMENSIONS

**\*PC14[24-60]H41\*\***

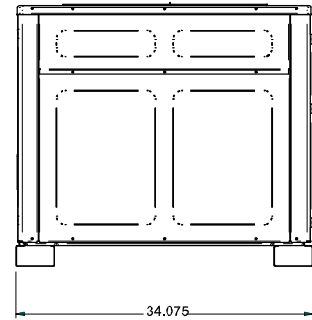
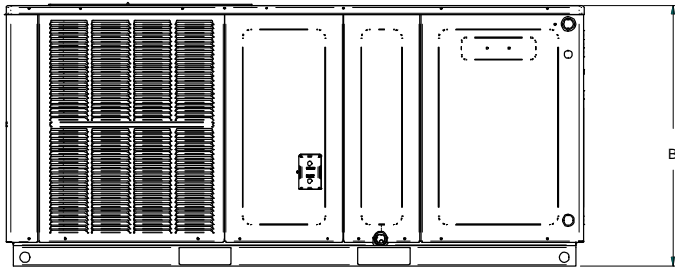
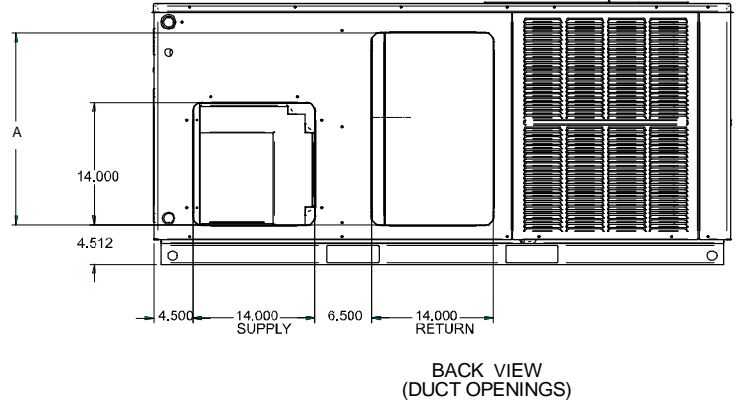
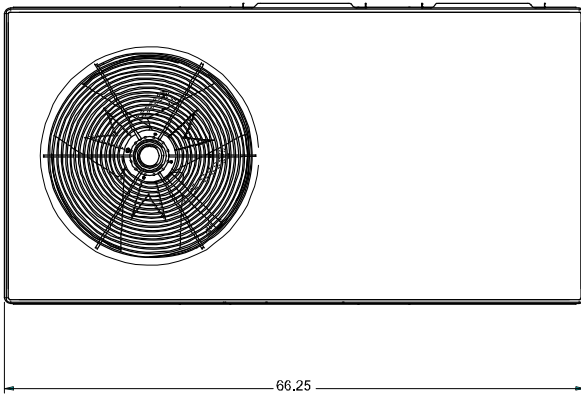

Chassis	Model	A	B
Small	*PC1424	22	30
	*PC1430	22	30
Medium	*PC1436	24	35
	*PC1442	24	35
Large	*PC1448	24	38¾
	*PC1460	24	38¾

Dimensions in inches

**HKR ELECTRICAL DATA**

Model and Heat Kit Usage	Circuit #1		Circuit #2		Actual kW & BTU at 240V
	Minimum Circuit Ampacity at 208 / 240V	Maximum Overcurrent Protection (amps) at 208 / 240V	Minimum Circuit Ampacity at 208 / 240V	Maximum Overcurrent Protection (amps) at 208 / 240V	
<b>*PC1424H41*</b>		--			--
HKR05*,C*	24 / 27	30 / 30	--	--	4.75 / 16,200
HKR08*,C*	33 / 38	40 / 40	--	--	7.0 / 23,800
HKR10*,C*	45 / 51	60 / 60	--	--	9.5 / 32,400
<b>*PC1430H41*</b>		--			--
HKR05*,C*	24 / 27	30 / 30	--	--	4.75 / 16,200
HKR08*,C*	34 / 39	40 / 40	--	--	7.0 / 23,800
HKR10*,C*	45 / 52	60 / 60	--	--	9.5 / 32,400
HKR/P15*,C*	45 / 52	60 / 60	22 / 25	30 / 30	14.25 / 48,600
<b>*PC1436H41*</b>		--			--
HKR05*,C*	24 / 27	30 / 30	--	--	4.75 / 16,200
HKR08*,C*	34 / 39	40 / 40	--	--	7.0 / 23,800
HKR10*,C*	45 / 52	60 / 60	--	--	9.5 / 32,400
HKR/P15*,C*	45 / 52	60 / 60	22 / 25	30 / 30	14.25 / 48,600
<b>*PC1442H41*</b>		--			--
HKR05*,C*	25 / 27	30 / 30	--	--	4.75 / 16,200
HKR08*,C*	34 / 39	40 / 40	--	--	7.0 / 23,800
HKR10*,C*	46 / 52	60 / 60	--	--	9.5 / 32,400
HKR/P15*,C*	46 / 52	60 / 60	22 / 25	30 / 30	14.25 / 48,600
HKR/P20*,C*	46 / 52	60 / 60	43 / 49	60 / 60	19.5 / 66,500
<b>*PC1448H41*</b>		--			--
HKR05*,C*	25 / 28	30 / 30	--	--	4.75 / 16,200
HKR08*,C*	34 / 40	40 / 40	--	--	7.0 / 23,800
HKR10*,C*	46 / 53	60 / 60	--	--	9.5 / 32,400
HKR/P15*,C*	46 / 52	60 / 60	22 / 25	30 / 30	14.25 / 48,600
HKR/P20*,C*	46 / 52	60 / 60	43 / 49	60 / 60	19.5 / 66,500
<b>*PC1460H41*</b>		--			--
HKR05*,C*	26 / 30	30 / 30	--	--	4.75 / 16,200
HKR08*,C*	36 / 40	40 / 40	--	--	7.0 / 23,800
HKR10*,C*	48 / 54	60 / 60	--	--	9.5 / 32,400
HKR/P15*,C*	48 / 54	60 / 60	22 / 25	30 / 30	14.25 / 48,600
HKR/P20*,C*	48 / 54	60 / 60	43 / 49	60 / 60	19.5 / 66,500

**IMPORTANT NOTE:** A separate power supply is required for the HKR heater kit.



**WARNING**

All wires and overcurrent protection devices are sized for use with electric heaters only and without refrigeration. If heaters are not installed with above wire size, overheating and fire could occur. See PACKAGE COOLING SPECIFICATIONS section for minimum circuit ampacity and maximum overcurrent protection during refrigeration cycle.

# ACCESSORIES

**\*PC14[24-60]H41\*\***

<b>ACCESSORIES - *PC/*PH****H UNITS</b>	
<b>Part Number</b>	<b>Description</b>
OT18-60A	Outdoor Thermostat Kit w/Lockout Stat
OT/EHR18-60	Emergency Heat Relay Kit
HKR	Electric Heat Kit
PCCP101-103	Roof Curb
PCP101-103	Downflow Plenum Kit
PCP101-103R8	Downflow Plenum Kit w/ R-8 Insulation
PCEC101-103	Downflow Economizer for GPC-(H) A/C - To Be Used With PCP101-103
PCEH101-103	Downflow Economizer for GPH-(H) Heat Pump - To Be Used With PCP101-103
PCMD101-103	Manual Damper - To Be Used With PCP101-103
PCMDM101-103	Motorized Damper - To Be Used With PCP101-103
GPHMD101-103	Manual Damper for Horizontal Applications
SQRPCH101	Square to Round Adapters 16"&14"
SQRPCH102-103	Square to Round Adapters 18"&14"
SQRPC101	Square to Round Adapter - For Use With PCCP101-103 Curb 16" Rounds
SQRPC102-103	Square to Round Adapter For Use With PCCP101-103 Curb 18" Rounds
PCFR101-103	External Horizontal Filter Rack
PCEF101-103	Elbow & Flashing w/ R-8 Liner
CDK36	Flush Mount Concentric Duct Kit
CDK36515	Flush Mount Concentric Duct Kit w/ Filter
CDK36530	Step Down Concentric Duct Kit
CDK36535	Step Down Concentric Duct Kit w/ Filter
CDK4872	Flush Mount Concentric Duct Kit
CDK4872515	Flush Mount Concentric Duct Kit w/ Filter
CDK4872530	Step Down Concentric Duct Kit
CDK4872535	Step Down Concentric Duct Kit w/ Filter
SPK30-60	Single Point Wiring Kit



# BLOWER PERFORMANCE DATA

# GPC14[24-60]H41A\*/B\*

Dry Coil Data

Model	Speed	Volts		E.S.P (In. of H <sub>2</sub> O)							
				0.1	0.2	0.3	0.4	0.5	0.6	0.7	0.8
GPC1424H41A*/B*	T1	230	CFM	934	759	755	638	581	489	-	-
			WATTS	95	77	76	73	83	90	-	-
	T2,T3	230	CFM	990	837	801	744	696	652	601	-
			WATTS	107	94	105	110	119	133	142	-
	T4, T5	230	CFM	1061	989	947	925	876	-	-	-
			WATTS	126	134	146	158	169	-	-	-
GPC1430H41A*/B*	T1	230	CFM	1022	929	894	829	797	748	695	643
			WATTS	116	114	126	134	144	156	168	173
	T2,T3	230	CFM	1103	1063	1012	962	937	-	-	-
			WATTS	142	154	165	173	185	-	-	-
	T4, T5	230	CFM	1285	1240	1202	1163	1124	1076	1046	1003
			WATTS	205	218	231	244	257	268	280	288
GPC1436H41A*/B*	T1	230	CFM	1234	1111	1071	1024	933	922	-	-
			WATTS	144	140	152	164	179	183	-	-
	T2,T3	230	CFM	1287	1232	1186	1133	1099	1053	-	-
			WATTS	162	175	187	201	213	221	-	-
	T4, T5	230	CFM	1381	1325	1277	1233	1181	1144	-	-
			WATTS	195	203	217	233	247	258	-	-
GPC1442H41A*/B*	T1	230	CFM	1272	1197	1145	1106	1055	998	947	906
			WATTS	160	168	183	191	211	220	230	243
	T2,T3	230	CFM	1357	1297	1244	1194	1147	1099	1049	1008
			WATTS	188	202	213	228	245	255	267	284
	T4, T5	230	CFM	1537	1478	1431	1386	1336	1293	1253	1208
			WATTS	244	258	274	288	303	317	329	341
GPC1448H41A*/B*	T1	230	CFM	1418	1383	1349	1312	1275	1228	1178	1141
			WATTS	242	258	273	282	299	308	320	338
	T2,T3	230	CFM	1175	1635	1645	1515	1510	1450	1430	1400
			WATTS	395	420	435	445	455	465	470	475
	T4, T5	230	CFM	1845	1790	1715	1685	1590	1580	1530	1500
			WATTS	490	505	520	535	550	560	570	575
GPC1460H41A*/B*	T1, T2, T3	230	CFM	1850	1765	1710	1625	1575	1535	1495	1435
			WATTS	360	375	380	390	400	410	420	430
	T4, T5	230	CFM	2025	1900	1840	1780	1725	1650	1620	1580
			WATTS	575	595	620	630	645	655	660	670

**NOTES:**

1. Data shown is dry coil. Wet coil pressure drop is approx.
2. 0.1" H<sub>2</sub>O, for 2 row indoor coil; 0.2" H<sub>2</sub>O, for 3 row indoor coil; and 0.3" H<sub>2</sub>O, for 4 row indoor coil.
3. Data shown does not include filter pressure drop, approx. 0.08" H<sub>2</sub>O.
4. Reduce airflow by 2% for 208V operation.

# BLOWER PERFORMANCE DATA

# GPC14[24-60]H41CA

Dry Coil Data

Model	Speed	Volts		E.S.P (In. of H <sub>2</sub> O)							
				0.1	0.2	0.3	0.4	0.5	0.6	0.7	0.8
GPC1424H41CA	T1	230	CFM	922	873	823	774	724	675	626	576
			WATTS	74	85	96	107	118	129	140	151
	T2, T3	230	CFM	922	873	823	774	724	675	626	576
			WATTS	74	85	96	107	118	129	140	151
	T4, T5	230	CFM	1069	1020	971	921	872	822	773	724
			WATTS	102	113	124	135	146	157	168	179
GPC1430H41CA	T1	230	CFM	1048	993	939	884	829	775	720	666
			WATTS	97	109	122	134	147	159	172	184
	T2, T3	230	CFM	1123	1068	1014	959	905	850	796	741
			WATTS	123	136	148	161	173	186	198	211
	T4, T5	230	CFM	1244	1189	1135	1080	1026	971	917	862
			WATTS	158	170	183	195	208	220	233	245
GPC1436H41CA	T1	230	CFM	1151	1097	1042	988	933	879	824	770
			WATTS	132	144	156	169	181	194	206	219
	T2, T3	230	CFM	1261	1215	1169	1123	1076	1030	984	937
			WATTS	131	144	157	169	182	194	207	220
	T4, T5	230	CFM	1376	1330	1284	1237	1191	1145	1099	1052
			WATTS	170	182	195	207	220	233	245	258
GPC1442H41CA	T1	230	CFM	1165	1122	1080	1037	995	953	910	868
			WATTS	118	130	142	154	166	178	190	202
	T2, T3	230	CFM	1258	1216	1173	1131	1088	1046	1004	961
			WATTS	150	162	175	187	199	211	223	235
	T4, T5	230	CFM	1511	1469	1427	1384	1342	1299	1257	1214
			WATTS	239	251	263	275	287	299	311	323
GPC1448H41CA	T1	230	CFM	1421	1367	1314	1260	1206	1152	1099	1045
			WATTS	170	182	195	208	220	233	246	258
	T2, T3	230	CFM	1696	1643	1589	1535	1481	1428	1374	1320
			WATTS	287	299	312	325	337	350	363	375
	T4, T5	230	CFM	1859	1805	1751	1698	1644	1590	1536	1483
			WATTS	356	368	381	394	406	419	432	444
GPC1460H41CA	T1	230	CFM	1507	1459	1410	1362	1314	1266	1218	1169
			WATTS	168	175	183	191	199	207	214	222
	T2, T3	230	CFM	1694	1646	1598	1549	1501	1453	1405	1357
			WATTS	296	303	311	319	327	334	342	350
	T4, T5	230	CFM	1965	1917	1869	1821	1773	1724	1676	1628
			WATTS	481	489	496	504	512	520	528	535

# BLOWER PERFORMANCE DATA

**\*PC14[24-60]H41D\***

Model	Speed	Volts		E.S.P. (In. of H <sub>2</sub> O)							
				0.1	0.2	0.3	0.4	0.5	0.6	0.7	0.8
*PC1424HD*	T1	230	CFM	922	873	823	774	724	675	626	576
			Watts	74	85	96	107	118	129	140	151
	T2 / T3	230	CFM	922	873	823	774	724	675	626	576
			Watts	74	85	96	107	118	129	140	151
	T4 / T5	230	CFM	1231	1179	1127	1074	1022	969	917	865
			Watts	168	180	193	205	218	230	243	255
*PC1430HD*	T1	230	CFM	1048	993	939	884	829	775	720	666
			Watts	97	109	122	134	147	159	172	184
	T2 / T3	230	CFM	1123	1068	1014	959	905	850	796	741
			Watts	123	136	148	161	173	186	198	211
	T4 / T5	230	CFM	1462	1409	1357	1305	1252	1200	1147	1095
			Watts	241	253	266	278	291	303	315	328
*PC1436H41D*	T1	230	CFM	1151	1097	1042	988	933	879	824	770
			Watts	132	144	156	169	181	194	206	219
	T2 / T3	230	CFM	1261	1215	1169	1123	1076	1030	984	937
			Watts	131	144	157	169	182	194	207	220
	T4 / T5	230	CFM	1577	1525	1472	1420	1367	1315	1263	1210
			Watts	277	290	302	314	327	339	352	364
*PC1442H41D*	T1	230	CFM	1165	1122	1080	1037	995	953	910	868
			Watts	118	130	142	154	166	178	190	202
	T2 / T3	230	CFM	1258	1216	1173	1131	1088	1046	1004	961
			Watts	150	162	175	187	199	211	223	235
	T4 / T5	230	CFM	1645	1602	1560	1517	1475	1433	1390	1348
			Watts	285	297	309	321	333	346	358	370
*PC1448H41D*	T1	230	CFM	1421	1367	1314	1260	1206	1152	1099	1045
			Watts	170	182	195	208	220	233	246	258
	T2 / T3	230	CFM	1696	1643	1589	1535	1481	1428	1374	1320
			Watts	287	299	312	325	337	350	363	375
	T4 / T5	230	CFM	1983	1928	1873	1818	1763	1708	1652	1597
			Watts	553	565	578	591	603	616	629	641
*PC1460H41D*	T1	230	CFM	1507	1459	1410	1362	1314	1266	1218	1169
			Watts	168	175	183	191	199	207	214	222
	T2 / T3	230	CFM	1694	1646	1598	1549	1501	1453	1405	1357
			Watts	296	303	311	319	327	334	342	350
	T4 / T5	230	CFM	1919	1870	1822	1774	1726	1678	1629	1581
			Watts	449	457	465	472	480	488	496	503

# BLOWER PERFORMANCE DATA

BTU OUTPUT vs TEMPERATURE RISE CHART

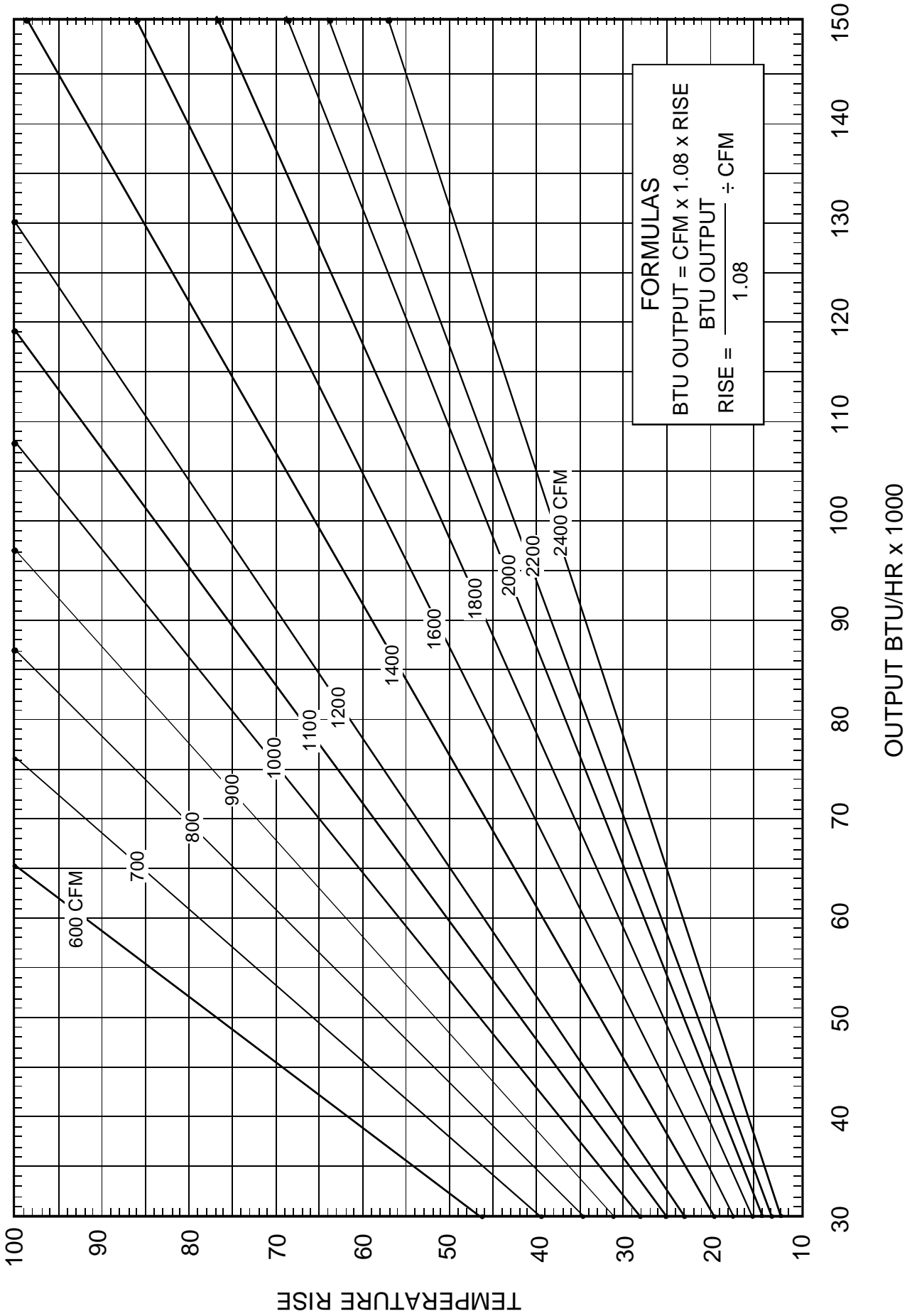

# PACKAGE COOLING SPECIFICATIONS GPC14[24-36]H41AA

		GPC1424H41AA	GPC1430H41AA	GPC1436H41AA
<b>COOLING CAPACITY</b>	COOLING CAPACITY, BTUH	24,600	28,400	35,600
	SEER / EER	14.5 / 12.1	14.0 / 12.1	14.0 / 12.0
<b>UNIT ELECTRICAL SPECIFICATION</b>	VOLTAGE (NAMEPLATE)	208-230/1/60	208-230/1/60	208-230/1/60
	AMPS (TOTAL)	10.5	13.16	20.06
	MINIMUM CIRCUIT AMPACITY	12.5	15.6	24.2
	MAXIMUM OVERCURRENT PROTECTION <sup>(1)</sup>	20	25	40
<b>COMPRESSOR</b>	TYPE	RECIP	RECIP	SCROLL
	RATED LOAD AMPS	7.9	9.8	16.7
	LOCKED ROTOR AMPS	41	55	79
<b>CONDENSER FAN MOTOR</b>	HORSEPOWER	1/6	1/4	1/4
	RPM	815	830	830
	FULL LOAD AMPS	1.1	1.5	1.5
	LOCKED ROTOR AMPS	1.7	3.0	3.0
<b>CONDENSER FAN</b>	BLADE DIAMETER (INCHES) / # OF BLADES	22 / 3	22 / 3	22 / 3
<b>CONDENSER COIL</b>	FACE AREA - SQ. FT.	13.4	13.4	13.4
	NUMBER OF ROWS	1	1	1
	FINS PER INCH	24	24	24
<b>EVAPORATOR BLOWER MOTOR</b>	HORSEPOWER - NO. OF SPEEDS	1/2 - 5	1/2 - 5	1/2 - 5
	FULL LOAD AMPS	1.5	1.86	1.86
	LOCKED ROTOR AMPS	NA	NA	NA
	MOTOR SPEED TAP - COOLING	T2	T2	T2
	RPM	1050	1050	1050
<b>EVAPORATOR BLOWER</b>	DIAMETER X WIDTH (INCHES)	10 X 8	10 X 8	10 X 8
	HI EFFICIENCY COOLING CFM	850	1,050	1,200
	5 TON NOMINAL COOLING CFM	NA	NA	NA
	FAN ONLY COOLING CFM	800	950	1,100
	MAX EXTERNAL STATIC PRESS ("w.c.)	0.5	0.5	0.5
<b>EVAPORATOR COIL</b>	FACE AREA - SQ. FT.	5.25	5.25	5.2
	NUMBER OF ROWS	3	3	3
	FINS PER INCH	16	16	14
<b>GENERAL INFORMATION</b>	FILTER SIZE - SQ. FT. *	20 x 20 x 1	20 x 25 x 1	25 x 25 x 1
	DRAIN SIZE (INCHES)	3/4"	3/4"	3/4"
	EXPANSION DEVICE	ORIFICE (0.057)	ORIFICE (0.060)	ORIFICE (0.065)
	REFRIGERANT CHARGE R-410A (Oz.)	83	78	80
	POWER SUPPLY CONDUIT KNOCKOUT SIZE (IN.)	3/4, 1, 1-1/4	3/4, 1, 1-1/4	3/4, 1, 1-1/4
	LOW VOLTAGE CONDUIT KNOCKOUT SIZE (IN.)	1/2	1/2	1/2
	SHIPPING WEIGHT LBS.	310	310	370
	OPERATING WEIGHT LBS.	300	300	360

<sup>(1)</sup> Maximum Overcurrent Protection Device: **MUST** use Time Delay Fuse or HACR type Circuit Breaker of the same size as noted.

\* Calculated external filter size based on air velocity of 300 ft/min.

Wire size should be determined in accordance with National Electrical Codes. Extensive wire runs will require larger wire sizes.

Unit specifications are subject to change without notice. **ALWAYS** refer to the units serial plate for the most up-to-date general and electrical information.

**IMPORTANT:** While this data is presented as a guide, it is important to electrically connect the unit and properly size wires and fuses/circuit breakers in accordance with the National Electrical Code and/or all local codes. Data shown is w/o electric heaters.

# PACKAGE COOLING SPECIFICATIONS      GPC14[42-60]H41AA

		GPC1442H41AA	GPC1448H41AA	GPC1460H41AA
<b>COOLING CAPACITY</b>	COOLING CAPACITY, BTUH	40,000	46,500	57,500
	SEER / EER	14.2/ 12.0	14.5 / 12.0	14.5 / 12.0
<b>UNIT ELECTRICAL SPECIFICATION</b>	VOLTAGE (NAMEPLATE)	208-230/1/60	208-230/1/60	208-230/1/60
	AMPS (TOTAL)	22.2	24.2	30.7
	MINIMUM CIRCUIT AMPACITY	26.6	29.1	37.3
	MAXIMUM OVERCURRENT PROTECTION <sup>(1)</sup>	40	45	60
<b>COMPRESSOR</b>	TYPE	SCROLL	SCROLL	SCROLL
	RATED LOAD AMPS	17.9	19.9	26.4
	LOCKED ROTOR AMPS	112	109	134
<b>CONDENSER FAN MOTOR</b>	HORSEPOWER	1/4	1/4	1/4
	RPM	1075	1075	1075
	FULL LOAD AMPS	1.4	1.4	1.4
	LOCKED ROTOR AMPS	2.9	2.9	2.9
<b>CONDENSER FAN</b>	BLADE DIAMETER (INCHES) / # OF BLADES	22 / 4	22 / 4	22 / 4
<b>CONDENSER COIL</b>	FACE AREA - SQ. FT.	17.0	19.1	19.1
	NUMBER OF ROWS	1	1	2
	FINS PER INCH	24	21	16
<b>EVAPORATOR BLOWER MOTOR</b>	HORSEPOWER - NO. OF SPEEDS	1/2 - 5	3/4 - 5	3/4 - 5
	FULL LOAD AMPS	2.9	2.9	2.9
	LOCKED ROTOR AMPS	NA	NA	NA
	MOTOR SPEED TAP - COOLING	T2	T2	T2
	RPM	1050	1050	1050
<b>EVAPORATOR BLOWER</b>	DIAMETER X WIDTH (INCHES)	10 x 8	10 x 8	11 x 8
	HI EFFICIENCY COOLING CFM	1,300	1,600	1,600
	5 TON NOMINAL COOLING CFM	NA	NA	1,800
	FAN ONLY COOLING CFM	1,200	1,400	1,600
	MAX EXTERNAL STATIC PRESS ("w.c.)	0.5	0.5	0.5
<b>EVAPORATOR COIL</b>	FACE AREA - SQ. FT.	6.2	6.2	7.0
	NUMBER OF ROWS	4	4	4
	FINS PER INCH	14	14	14
<b>GENERAL INFORMATION</b>	FILTER SIZE - SQ. FT. *	(2) 20 x 20 x 1	(2) 20 x 20 x 1	(2) 20 x 25 x 1
	DRAIN SIZE (INCHES)	3/4"	3/4"	3/4"
	EXPANSION DEVICE	ORIFICE (0.072)	ORIFICE (0.076)	ORIFICE (0.088)
	REFRIGERANT CHARGE R-410A (Oz.)	118	123	188
	POWER SUPPLY CONDUIT KNOCKOUT SIZE (IN.)	3/4, 1, 1-1/4	3/4, 1, 1-1/4	3/4, 1, 1-1/4
	LOW VOLTAGE CONDUIT KNOCKOUT SIZE (IN.)	1/2	1/2	1/2
	SHIPPING WEIGHT LBS.	370	400	400
	OPERATING WEIGHT LBS.	360	390	390

<sup>(1)</sup> Maximum Overcurrent Protection Device: **MUST** use Time Delay Fuse or HACR type Circuit Breaker of the same size as noted.

\* Calculated external filter size based on air velocity of 300 ft/min.

Wire size should be determined in accordance with National Electrical Codes. Extensive wire runs will require larger wire sizes.

Unit specifications are subject to change without notice. **ALWAYS** refer to the units serial plate for the most up-to-date general and electrical information.

**IMPORTANT:** While this data is presented as a guide, it is important to electrically connect the unit and properly size wires and fuses/circuit breakers in accordance with the National Electrical Code and/or all local codes. Data shown is w/o electric heaters.

# COOLING PERFORMANCE DATA

# GPC1424H41AA

MODEL: GPC1424H41A\*

## EXPANDED PERFORMANCE DATA

COOLING OPERATION

IDB*	Airflow	Outdoor Ambient Temperature																								
		65				75				85				95				105				115				
		59	63	67	71	59	63	67	71	59	63	67	71	59	63	67	71	59	63	67	71	59	63	67	71	
70	955	MBh	24.1	25.0	27.4	-	23.5	24.4	26.7	-	23.0	23.8	26.1	-	22.4	23.2	25.5	-	21.3	22.1	24.2	-	19.7	20.5	22.4	-
		S/T	0.74	0.62	0.43	-	0.77	0.64	0.45	-	0.79	0.66	0.46	-	0.82	0.68	0.47	-	0.85	0.71	0.49	-	0.85	0.71	0.49	-
		Delta T	17	15	11	-	17	15	11	-	17	15	11	-	18	15	12	-	17	15	11	-	16	14	11	-
		KW	1.57	1.60	1.66	-	1.70	1.73	1.79	-	1.81	1.85	1.91	-	1.91	1.95	2.02	-	1.99	2.04	2.11	-	2.06	2.11	2.19	-
		AMPS	6.6	6.8	7.0	-	7.1	7.3	7.5	-	7.7	7.9	8.1	-	8.2	8.4	8.7	-	8.7	8.9	9.2	-	9.2	9.4	9.7	-
		HI PR	233	251	265	-	262	282	298	-	298	321	338	-	339	365	386	-	382	411	434	-	422	454	479	-
		LO PR	111	118	129	-	118	125	137	-	122	130	142	-	128	137	149	-	135	143	156	-	139	148	162	-
		MBh	23.4	24.3	26.6	-	22.9	23.7	26.0	-	22.3	23.1	25.3	-	21.8	22.6	24.7	-	20.7	21.4	23.5	-	19.2	19.9	21.8	-
		S/T	0.71	0.59	0.41	-	0.73	0.61	0.42	-	0.75	0.63	0.44	-	0.78	0.65	0.45	-	0.81	0.67	0.47	-	0.81	0.68	0.47	-
		Delta T	18	16	12	-	18	16	12	-	18	16	12	-	18	16	12	-	18	16	12	-	17	15	11	-
745	860	KW	1.56	1.59	1.64	-	1.68	1.72	1.78	-	1.79	1.83	1.90	-	1.89	1.93	2.00	-	1.97	2.02	2.09	-	2.05	2.09	2.17	-
		AMPS	6.6	6.7	6.9	-	7.1	7.2	7.5	-	7.7	7.8	8.1	-	8.1	8.3	8.6	-	8.6	8.8	9.1	-	9.1	9.3	9.6	-
		HI PR	231	249	263	-	259	279	295	-	295	317	335	-	336	361	382	-	378	407	429	-	418	449	474	-
		LO PR	110	117	128	-	116	124	135	-	121	129	141	-	127	135	148	-	133	142	155	-	138	147	160	-
		MBh	21.6	22.4	24.5	-	21.1	21.9	24.0	-	20.6	21.3	23.4	-	20.1	20.8	22.8	-	19.1	19.8	21.7	-	17.7	18.3	20.1	-
		S/T	0.68	0.57	0.40	-	0.71	0.59	0.41	-	0.73	0.61	0.42	-	0.75	0.63	0.43	-	0.78	0.65	0.45	-	0.78	0.66	0.45	-
		Delta T	18	16	12	-	18	16	12	-	18	16	12	-	19	16	12	-	18	16	12	-	17	15	11	-
		KW	1.52	1.55	1.60	-	1.64	1.68	1.73	-	1.75	1.79	1.85	-	1.84	1.88	1.95	-	1.92	1.97	2.03	-	1.99	2.04	2.11	-
		AMPS	6.4	6.6	6.8	-	6.9	7.1	7.3	-	7.5	7.6	7.9	-	7.9	8.1	8.4	-	8.4	8.6	8.9	-	8.9	9.1	9.4	-
		HI PR	224	241	255	-	252	271	286	-	286	308	325	-	326	351	370	-	367	394	417	-	405	436	460	-
LO PR	107	114	124	-	113	120	131	-	117	125	136	-	123	131	143	-	129	137	150	-	134	142	155	-		
75	955	MBh	24.5	25.2	27.3	29.3	23.9	24.7	26.7	28.6	23.4	24.1	26.0	28.0	22.8	23.5	25.4	27.3	21.7	22.3	24.1	25.9	20.1	20.7	22.4	24.0
		S/T	0.84	0.76	0.57	0.37	0.88	0.78	0.59	0.38	0.90	0.80	0.61	0.39	0.93	0.83	0.63	0.40	0.96	0.86	0.65	0.42	0.97	0.87	0.66	0.42
		Delta T	20	18	15	10	20	19	15	11	20	19	15	11	20	19	15	11	20	18	15	10	19	17	14	10
		KW	1.58	1.62	1.67	1.73	1.71	1.75	1.81	1.87	1.82	1.87	1.93	2.00	1.92	1.97	2.04	2.11	2.01	2.06	2.13	2.20	2.08	2.13	2.20	2.28
		AMPS	6.7	6.8	7.1	7.3	7.2	7.4	7.6	7.9	7.8	8.0	8.2	8.5	8.3	8.5	8.7	9.1	8.8	9.0	9.3	9.6	9.3	9.5	9.8	10.2
		HI PR	236	254	268	279	265	285	301	314	301	324	342	357	343	369	389	406	386	415	438	457	426	458	484	505
		LO PR	112	120	131	139	119	126	138	147	123	131	143	153	130	138	151	160	136	145	158	168	141	150	163	174
		MBh	23.8	24.5	26.5	28.5	23.2	23.9	25.9	27.8	22.7	23.4	25.3	27.1	22.1	22.8	24.7	26.5	21.0	21.7	23.4	25.2	19.5	20.1	21.7	23.3
		S/T	0.81	0.72	0.55	0.35	0.83	0.75	0.57	0.36	0.86	0.77	0.58	0.37	0.88	0.79	0.60	0.38	0.92	0.82	0.62	0.40	0.92	0.83	0.63	0.40
		Delta T	21	19	16	11	21	19	16	11	21	19	16	11	21	19	16	11	21	19	16	11	19	18	15	10
745	850	KW	1.57	1.60	1.66	1.71	1.70	1.73	1.79	1.85	1.81	1.85	1.91	1.98	1.91	1.95	2.02	2.09	1.99	2.04	2.11	2.18	2.06	2.11	2.19	2.26
		AMPS	6.6	6.8	7.0	7.2	7.1	7.3	7.5	7.8	7.7	7.9	8.1	8.4	8.2	8.4	8.7	9.0	8.7	8.9	9.2	9.5	9.2	9.4	9.7	10.1
		HI PR	233	251	265	277	262	282	298	310	298	321	339	353	339	365	386	402	382	411	434	452	422	454	479	500
		LO PR	111	118	129	138	118	125	137	145	122	130	142	151	128	137	149	159	135	143	156	166	139	148	162	172
		MBh	22.0	22.6	24.5	26.3	21.5	22.1	23.9	25.7	20.9	21.6	23.3	25.1	20.4	21.0	22.8	24.4	19.4	20.0	21.6	23.2	18.0	18.5	20.0	21.5
		S/T	0.78	0.69	0.53	0.34	0.81	0.72	0.55	0.35	0.83	0.74	0.56	0.36	0.85	0.76	0.58	0.37	0.88	0.79	0.60	0.39	0.89	0.80	0.60	0.39
		Delta T	21	19	16	11	21	20	16	11	21	20	16	11	21	20	16	11	21	20	16	11	20	18	15	10
		KW	1.53	1.56	1.61	1.67	1.65	1.69	1.75	1.81	1.76	1.80	1.86	1.93	1.86	1.90	1.97	2.03	1.94	1.98	2.05	2.12	2.01	2.06	2.13	2.20
		AMPS	6.5	6.6	6.8	7.1	7.0	7.1	7.3	7.6	7.5	7.7	7.9	8.2	8.0	8.2	8.4	8.7	8.5	8.7	9.0	9.3	9.0	9.2	9.5	9.8
		HI PR	226	244	257	268	254	273	289	301	289	311	328	343	329	354	374	390	370	398	421	439	409	440	465	485
LO PR	108	115	125	134	114	121	133	141	119	126	138	147	125	133	145	154	131	139	152	161	135	144	157	167		

\* IDB: Entering Indoor Dry Bulb Temperature

High and low pressures are measured at the liquid and suction access fittings.

NOTE: Shaded area is ACCA (TVA) conditions

# COOLING PERFORMANCE DATA

# GPC1424H41AA

IDB*	Airflow	Outdoor Ambient Temperature																														
		65					75					85					95					105					115					
		59	63	67	71	75	59	63	67	71	75	59	63	67	71	75	59	63	67	71	75	59	63	67	71	75	59	63	67	71	75	
955	MBh	25.0	25.5	27.2	29.1	31.0	24.4	24.9	26.6	28.4	30.3	23.8	24.3	26.0	27.8	29.7	23.2	23.7	25.3	27.1	29.0	22.0	22.5	24.1	25.7	27.4	20.4	20.9	22.3	23.8	25.3	
	S/T	0.93	0.87	0.71	0.53	0.35	0.96	0.90	0.73	0.55	0.37	1.00	0.92	0.75	0.56	0.38	1.00	0.95	0.78	0.58	0.39	1.00	1.00	0.81	0.60	0.40	1.00	1.00	0.81	0.60	0.41	
	Delta T	22	21	19	15	11	23	22	19	15	11	22	22	19	15	11	22	22	19	15	11	23	22	19	15	11	20	20	17	14	11	
	KW	1.60	1.63	1.69	1.74	1.79	1.72	1.76	1.82	1.89	1.94	1.84	1.88	1.95	2.01	2.06	1.94	1.99	2.05	2.13	2.20	2.03	2.07	2.15	2.22	2.30	2.10	2.15	2.22	2.30	2.38	
	AMPS	6.8	6.9	7.1	7.4	7.7	7.3	7.4	7.7	7.9	8.2	7.9	8.0	8.3	8.6	8.9	8.4	8.6	8.8	9.1	9.4	8.9	9.1	9.4	9.7	10.0	9.4	9.6	9.9	10.3	10.7	
	HI PR	238	256	271	282	291	267	288	304	317	324	304	327	345	360	373	346	373	393	410	428	389	419	443	462	481	430	463	489	510	531	
	LO PR	114	121	132	140	148	120	128	139	148	157	125	133	145	154	163	131	139	152	162	171	137	146	159	170	180	142	151	165	176	187	
	MBh	24.2	24.8	26.4	28.3	30.2	23.7	24.2	25.8	27.6	29.5	23.1	23.6	25.2	27.0	28.9	22.5	23.0	24.6	26.3	28.2	21.4	21.9	23.4	25.0	26.8	19.8	20.3	21.6	23.1	24.8	
	S/T	0.88	0.83	0.67	0.50	0.34	0.92	0.86	0.70	0.52	0.36	0.94	0.88	0.72	0.54	0.38	0.97	0.91	0.74	0.55	0.39	1.00	0.94	0.77	0.57	0.41	1.00	0.95	0.77	0.58	0.42	
	Delta T	23	22	19	15	11	23	22	20	16	12	23	22	20	16	12	24	23	20	16	12	24	23	20	16	12	21	21	18	14	11	
KW	1.58	1.62	1.67	1.73	1.78	1.71	1.75	1.81	1.87	1.92	1.82	1.87	1.93	2.00	2.06	1.92	1.97	2.04	2.11	2.18	2.01	2.06	2.13	2.20	2.28	2.08	2.13	2.21	2.28	2.36		
AMPS	6.7	6.8	7.1	7.3	7.6	7.2	7.4	7.6	7.9	8.2	7.8	8.0	8.2	8.5	8.8	8.3	8.5	8.8	9.1	9.4	8.8	9.0	9.3	9.6	9.9	9.3	9.5	9.8	10.2	10.6		
HI PR	236	254	268	279	288	265	285	301	314	324	301	324	342	357	373	343	369	390	406	423	386	415	438	457	476	426	458	484	505	526		
LO PR	112	120	131	139	147	119	126	138	147	156	123	131	143	153	163	130	138	151	160	170	136	145	158	168	178	141	150	163	174	185		
850	MBh	22.4	22.8	24.4	26.1	27.9	21.8	22.3	23.8	25.5	27.3	21.3	21.8	23.3	24.9	26.6	20.8	21.3	22.7	24.3	26.0	19.8	20.2	21.6	23.1	24.8	18.3	18.7	20.0	21.4	23.0	
	S/T	0.85	0.80	0.65	0.49	0.34	0.88	0.83	0.67	0.50	0.35	0.91	0.85	0.69	0.52	0.37	0.93	0.88	0.71	0.53	0.38	0.97	0.91	0.74	0.55	0.40	0.98	0.92	0.75	0.56	0.41	
	Delta T	24	23	20	16	12	24	23	20	16	12	24	23	20	16	12	24	23	20	16	12	24	23	20	16	12	22	21	18	15	12	
	KW	1.54	1.58	1.63	1.68	1.73	1.67	1.70	1.76	1.82	1.88	1.78	1.82	1.88	1.94	2.00	1.87	1.92	1.98	2.05	2.12	1.96	2.00	2.07	2.14	2.21	2.03	2.07	2.15	2.22	2.30	
	AMPS	6.5	6.7	6.9	7.1	7.4	7.0	7.2	7.4	7.7	8.0	7.6	7.8	8.0	8.3	8.6	8.1	8.3	8.5	8.8	9.1	8.6	8.8	9.0	9.4	9.7	9.0	9.3	9.6	9.9	10.3	
	HI PR	229	246	260	271	280	257	276	292	304	314	292	314	332	346	361	332	358	378	394	410	374	403	425	443	461	413	445	470	490	510	
	LO PR	109	116	127	135	143	115	123	134	143	152	120	127	139	148	157	126	134	146	156	166	132	140	153	163	172	136	145	158	169	179	
	745	MBh	25.4	25.9	27.1	28.9	30.7	24.8	25.3	26.5	28.2	29.9	24.2	24.7	25.8	27.6	29.3	23.6	24.1	25.2	26.9	28.6	22.4	22.9	24.0	25.6	27.3	20.8	21.2	22.2	23.7	25.4
		S/T	0.97	0.94	0.85	0.69	0.53	1.00	0.97	0.88	0.71	0.55	1.00	1.00	0.90	0.73	0.57	1.00	1.00	0.93	0.75	0.59	1.00	1.00	0.96	0.78	0.62	1.00	1.00	0.97	0.79	0.63
		Delta T	24	23	22	19	15	24	24	22	19	15	23	24	22	19	15	23	23	23	19	15	22	22	22	19	15	20	20	21	18	15
KW		1.61	1.64	1.70	1.76	1.81	1.74	1.78	1.84	1.90	1.96	1.86	1.90	1.96	2.03	2.09	1.96	2.00	2.07	2.14	2.21	2.04	2.09	2.16	2.24	2.31	2.12	2.17	2.24	2.32	2.40	
AMPS		6.8	7.0	7.2	7.4	7.7	7.3	7.5	7.7	8.0	8.4	7.9	8.1	8.4	8.7	9.0	8.4	8.6	8.9	9.2	9.5	8.9	9.2	9.5	9.8	10.1	9.5	9.7	10.0	10.4	10.8	
HI PR		241	259	273	285	294	270	290	307	320	330	307	330	349	364	379	350	376	397	414	431	393	423	447	466	484	435	468	494	515	536	
LO PR		115	122	133	142	150	121	129	141	150	159	126	134	146	156	165	132	141	154	164	174	139	148	161	172	182	143	153	167	177	187	
85		MBh	24.6	25.1	26.3	28.1	29.9	24.1	24.5	25.7	27.4	29.1	23.5	24.0	25.1	26.8	28.5	22.9	23.4	24.5	26.1	27.8	21.8	22.2	23.3	24.8	26.5	20.2	20.6	21.5	23.0	24.7
		S/T	0.93	0.89	0.81	0.65	0.49	0.96	0.93	0.84	0.68	0.52	0.98	0.95	0.86	0.70	0.54	1.00	0.98	0.88	0.72	0.57	1.00	1.00	0.92	0.75	0.60	1.00	1.00	0.93	0.75	0.60
		Delta T	25	24	23	20	16	25	25	23	20	16	25	25	23	20	16	25	25	23	20	16	24	24	23	20	16	22	22	22	19	15
	KW	1.60	1.63	1.69	1.74	1.79	1.72	1.76	1.82	1.89	1.94	1.84	1.88	1.95	2.01	2.07	1.94	1.99	2.05	2.13	2.20	2.03	2.07	2.15	2.22	2.30	2.10	2.15	2.22	2.30	2.38	
	AMPS	6.8	6.9	7.1	7.4	7.7	7.3	7.4	7.7	7.9	8.3	7.9	8.0	8.3	8.6	8.9	8.4	8.6	8.8	9.1	9.4	8.9	9.1	9.4	9.7	10.0	9.4	9.6	9.9	10.3	10.7	
	HI PR	238	256	271	282	291	267	288	304	317	327	304	327	345	360	376	346	373	393	410	428	389	419	443	462	481	430	463	489	510	531	
	LO PR	114	121	132	140	148	120	128	139	148	157	125	133	145	154	163	131	139	152	162	171	137	146	159	170	180	142	151	165	176	187	
	745	MBh	22.7	23.2	24.3	25.9	27.5	22.2	22.6	23.7	25.3	27.0	21.7	22.1	23.2	24.7	26.4	21.2	21.6	22.6	24.1	25.8	20.1	20.5	21.5	22.9	24.6	18.6	19.0	19.9	21.2	22.9
		S/T	0.89	0.86	0.78	0.63	0.48	0.93	0.89	0.81	0.65	0.50	0.95	0.92	0.83	0.67	0.52	0.98	0.95	0.85	0.69	0.54	1.00	0.98	0.89	0.72	0.57	1.00	0.99	0.89	0.72	0.57
		Delta T	25	25	23	20	16	25	25	24	20	16	25	25	24	20	16	26	25	24	21	17	25	25	23	20	16	23	23	22	19	15
KW		1.56	1.59	1.64	1.70	1.75	1.68	1.72	1.78	1.84	1.90	1.79	1.83	1.90	1.96	2.02	1.89	1.93	2.00	2.07	2.14	1.97	2.02	2.09	2.16	2.24	2.05	2.09	2.17	2.24	2.32	
AMPS		6.6	6.7	6.9	7.2	7.5	7.1	7.2	7.5	7.7	8.1	7.7	7.8	8.1	8.4	8.8	8.1	8.3	8.6	8.9	9.3	8.6	8.8	9.1	9.4	9.7	9.1	9.3	9.6	10.0	10.4	
HI PR		231	249	263	274	283	259	279	295	307	317	295	317	335	349	364	336	361	382	398	414	378	407	429	448	467	417	449	474	495	516	
LO PR		110	117	128	136	144	116	124	135	144	153	121	129	141	150	159	127	135	148	157	166	133	142	155	165	174	138	147	160	170	180	

NOTE: Shaded area reflects AHRF rating conditions

IDB*	Airflow	Outdoor Ambient Temperature																													
		65					75					85					95					105					115				
		59	63	67	71	75	59	63	67	71	75	59	63	67	71	75	59	63	67	71</											



# COOLING PERFORMANCE DATA

# GPC1430H41AA

## EXPANDED PERFORMANCE DATA

## EXPANDED PERFORMANCE DATA

## MODEL: GPC1430H41A\*

## COOLING OPERATION

IDB*	Airflow	Outdoor Ambient Temperature																							
		65				75				85				95				105				115			
		59	63	67	71	59	63	67	71	59	63	67	71	59	63	67	71	59	63	67	71	59	63	67	71
70	MBh	27.8	28.8	31.6	-	27.2	28.2	30.9	-	26.5	27.5	30.1	-	25.9	26.8	29.4	-	24.6	25.5	27.9	-	22.8	23.6	25.9	-
	S/T	0.76	0.63	0.44	-	0.79	0.66	0.46	-	0.81	0.67	0.47	-	0.83	0.70	0.48	-	0.87	0.72	0.50	-	0.87	0.73	0.50	-
	Delta T	16	14	11	-	17	14	11	-	17	14	11	-	17	15	11	-	17	14	11	-	15	13	10	-
	KW	1.86	1.90	1.96	-	2.01	2.06	2.12	-	2.14	2.19	2.27	-	2.26	2.31	2.39	-	2.36	2.41	2.50	-	2.44	2.50	2.59	-
	AMPS	7.7	7.9	8.1	-	8.3	8.5	8.7	-	8.9	9.1	9.4	-	9.5	9.7	10.0	-	10.1	10.3	10.7	-	10.7	10.9	11.3	-
	HI PR	240	258	272	-	269	289	305	-	306	329	347	-	348	375	396	-	392	421	445	-	433	466	492	-
	LO PR	111	119	129	-	118	125	137	-	122	130	142	-	128	137	149	-	135	143	156	-	139	148	162	-
	MBh	27.0	28.0	30.7	-	26.4	27.4	30.0	-	25.8	26.7	29.3	-	25.1	26.1	28.5	-	23.9	24.7	27.1	-	22.1	22.9	25.1	-
	S/T	0.73	0.61	0.42	-	0.75	0.63	0.43	-	0.77	0.64	0.45	-	0.80	0.66	0.46	-	0.83	0.69	0.48	-	0.83	0.70	0.48	-
	Delta T	17	15	11	-	17	15	11	-	17	15	11	-	18	15	11	-	17	15	11	-	16	14	11	-
1050	KW	1.84	1.89	1.95	-	1.99	2.04	2.11	-	2.12	2.17	2.25	-	2.24	2.29	2.37	-	2.34	2.39	2.47	-	2.42	2.48	2.56	-
	AMPS	7.6	7.8	8.0	-	8.2	8.4	8.6	-	8.9	9.1	9.3	-	9.4	9.6	10.0	-	10.0	10.2	10.6	-	10.6	10.8	11.2	-
	HI PR	237	255	269	-	266	286	302	-	303	326	344	-	345	371	392	-	388	417	441	-	428	461	487	-
	LO PR	110	117	128	-	117	124	135	-	121	129	141	-	127	135	148	-	133	142	155	-	138	147	160	-
	MBh	24.9	25.8	28.3	-	24.4	25.2	27.7	-	23.8	24.6	27.0	-	23.2	24.0	26.3	-	22.0	22.8	25.0	-	20.4	21.2	23.2	-
	S/T	0.70	0.58	0.40	-	0.72	0.61	0.42	-	0.74	0.62	0.43	-	0.77	0.64	0.44	-	0.80	0.66	0.46	-	0.80	0.67	0.46	-
	Delta T	17	15	11	-	18	15	12	-	18	15	12	-	18	15	12	-	18	15	12	-	16	14	11	-
	KW	1.80	1.84	1.90	-	1.94	1.99	2.05	-	2.07	2.12	2.19	-	2.18	2.23	2.31	-	2.28	2.33	2.41	-	2.36	2.41	2.50	-
	AMPS	7.4	7.6	7.8	-	8.0	8.2	8.4	-	8.6	8.8	9.1	-	9.2	9.4	9.7	-	9.7	10.0	10.3	-	10.3	10.5	10.9	-
	HI PR	230	248	261	-	258	278	293	-	294	316	334	-	334	360	380	-	376	405	427	-	416	447	472	-
LO PR	107	114	124	-	113	120	131	-	117	125	136	-	123	131	143	-	129	138	150	-	134	142	155	-	

IDB*	Airflow	Outdoor Ambient Temperature																							
		65				75				85				95				105				115			
		59	63	67	71	59	63	67	71	59	63	67	71	59	63	67	71	59	63	67	71	59	63	67	71
75	MBh	28.3	29.1	31.5	33.9	27.6	28.5	30.8	33.1	27.0	27.8	30.1	32.3	26.3	27.1	29.3	31.5	25.0	25.8	27.9	29.9	23.2	23.9	25.8	27.7
	S/T	0.86	0.77	0.58	0.38	0.90	0.80	0.61	0.39	0.92	0.82	0.62	0.40	0.95	0.85	0.64	0.41	0.98	0.88	0.67	0.43	0.99	0.89	0.67	0.43
	Delta T	19	18	14	10	19	18	15	10	19	18	15	10	19	18	15	10	19	18	14	10	18	16	14	9
	KW	1.88	1.92	1.98	2.05	2.03	2.07	2.14	2.22	2.16	2.21	2.29	2.36	2.28	2.33	2.41	2.49	2.38	2.43	2.52	2.61	2.47	2.52	2.61	2.70
	AMPS	7.8	7.9	8.2	8.5	8.3	8.5	8.8	9.1	9.0	9.2	9.5	9.8	9.6	9.8	10.1	10.5	10.2	10.4	10.7	11.1	10.8	11.0	11.4	11.8
	HI PR	242	260	275	287	272	292	309	322	309	332	351	366	352	378	400	417	396	426	450	469	437	470	497	518
	LO PR	113	120	131	139	119	126	138	147	124	131	143	153	130	138	151	161	136	145	158	168	141	150	163	174
	MBh	27.5	28.3	30.6	32.9	26.8	27.6	29.9	32.1	26.2	27.0	29.2	31.3	25.6	26.3	28.5	30.6	24.3	25.0	27.1	29.0	22.5	23.2	25.1	26.9
	S/T	0.82	0.74	0.56	0.36	0.85	0.76	0.58	0.37	0.88	0.78	0.59	0.38	0.90	0.81	0.61	0.39	0.94	0.84	0.64	0.41	0.95	0.85	0.64	0.41
	Delta T	20	18	15	10	20	18	15	10	20	19	15	10	20	19	15	11	20	18	15	10	19	17	14	10
1050	KW	1.86	1.90	1.96	2.03	2.01	2.06	2.12	2.20	2.14	2.19	2.27	2.34	2.26	2.31	2.39	2.47	2.36	2.41	2.50	2.58	2.44	2.50	2.59	2.68
	AMPS	7.7	7.9	8.1	8.4	8.3	8.5	8.7	9.0	8.9	9.1	9.4	9.8	9.5	9.7	10.0	10.4	10.1	10.3	10.7	11.0	10.7	10.9	11.3	11.7
	HI PR	240	258	272	284	269	289	305	319	306	329	347	362	348	375	396	413	392	422	445	464	433	466	492	513
	LO PR	111	119	129	138	118	125	137	146	122	130	142	151	128	137	149	159	135	143	156	167	139	148	162	172
	MBh	25.4	26.1	28.3	30.3	24.8	25.5	27.6	29.6	24.2	24.9	26.9	28.9	23.6	24.3	26.3	28.2	22.4	23.1	25.0	26.8	20.8	21.4	23.1	24.8
	S/T	0.79	0.71	0.54	0.35	0.82	0.74	0.56	0.36	0.84	0.76	0.57	0.37	0.87	0.78	0.59	0.38	0.90	0.81	0.61	0.39	0.91	0.82	0.62	0.40
	Delta T	20	19	15	10	20	19	15	11	20	19	15	11	21	19	16	11	20	19	15	11	19	17	14	10
	KW	1.81	1.85	1.92	1.98	1.96	2.00	2.07	2.14	2.09	2.14	2.21	2.28	2.20	2.25	2.33	2.41	2.30	2.35	2.43	2.52	2.38	2.44	2.52	2.61
	AMPS	7.5	7.7	7.9	8.2	8.1	8.2	8.5	8.8	8.7	8.9	9.2	9.5	9.3	9.5	9.8	10.1	9.8	10.1	10.4	10.7	10.4	10.6	11.0	11.4
	HI PR	232	250	264	275	261	281	296	309	297	319	337	351	338	363	384	400	380	409	432	450	420	452	477	498
LO PR	108	115	126	134	114	121	133	141	119	126	138	147	125	133	145	154	131	139	152	162	135	144	157	167	

\* IDB: Entering Indoor Dry Bulb Temperature

High and low pressures are measured at the liquid and suction access fittings.

# COOLING PERFORMANCE DATA

# GPC1430H41AA

IDB*	Airflow	Outdoor Ambient Temperature																													
		65					75					85					95					105					115				
		59	63	67	71	75	59	63	67	71	75	59	63	67	71	75	59	63	67	71	75	59	63	67	71	75					
80	1180	28.8	29.4	31.4	33.6	35.8	28.1	28.7	30.7	32.8	34.9	27.5	28.1	30.0	32.1	34.2	26.8	27.4	29.3	31.3	33.3	25.5	26.0	27.8	29.7	31.6	23.6	24.1	25.7	27.5	29.3
		0.95	0.89	0.72	0.54	0.37	1.00	0.92	0.75	0.56	0.39	1.00	0.94	0.77	0.57	0.40	1.00	1.00	0.79	0.59	0.39	1.00	1.00	0.82	0.62	0.42	1.00	1.00	0.83	0.62	0.42
		21	20	18	14	10	22	21	18	14	10	21	21	18	14	10	20	21	18	14	10	20	20	18	14	10	18	19	17	13	10
		1.89	1.93	2.00	2.07	2.14	2.04	2.09	2.16	2.23	2.30	2.18	2.23	2.30	2.38	2.45	2.30	2.35	2.43	2.52	2.60	2.40	2.46	2.54	2.63	2.71	2.49	2.55	2.63	2.73	2.81
		7.8	8.0	8.2	8.5	8.8	8.4	8.6	8.9	9.2	9.5	9.1	9.3	9.6	9.9	10.2	9.7	9.9	10.2	10.6	11.0	10.3	10.5	10.8	11.2	11.6	10.9	11.1	11.5	11.9	12.3
		244	263	278	290	302	274	295	312	325	337	312	336	354	370	385	355	382	404	421	438	400	430	454	474	494	442	475	502	523	544
		114	121	132	141	149	120	128	139	149	158	125	133	145	154	162	131	139	152	162	170	137	146	160	170	179	142	151	165	176	185
		28.0	28.6	30.5	32.6	34.7	27.3	27.9	29.8	31.9	34.0	26.7	27.2	29.1	31.1	33.1	26.0	26.6	28.4	30.4	32.4	24.7	25.3	27.0	28.8	30.6	22.9	23.4	25.0	26.7	28.4
		0.90	0.85	0.69	0.52	0.35	0.94	0.88	0.72	0.53	0.35	0.96	0.90	0.73	0.55	0.37	0.99	0.93	0.76	0.57	0.39	1.00	0.97	0.79	0.59	0.41	1.00	0.97	0.79	0.59	0.41
		22	21	18	15	12	22	21	19	15	12	22	21	19	15	12	23	22	19	15	12	22	21	19	15	12	20	20	17	14	11
1050		1.88	1.92	1.98	2.05	2.12	2.03	2.07	2.14	2.22	2.29	2.16	2.21	2.29	2.36	2.43	2.28	2.33	2.41	2.49	2.56	2.38	2.43	2.52	2.61	2.69	2.47	2.52	2.61	2.70	2.78
		7.8	7.9	8.2	8.5	8.8	8.3	8.5	8.8	9.1	9.4	9.0	9.2	9.5	9.8	10.1	9.6	9.8	10.1	10.5	10.9	10.2	10.4	10.7	11.1	11.4	10.8	11.0	11.4	11.8	12.1
		242	260	275	287	299	272	292	309	322	334	309	332	351	366	381	352	379	400	417	433	396	426	450	469	487	437	470	497	518	536
		113	120	131	139	147	119	126	138	147	154	124	131	144	153	161	130	138	151	161	170	136	145	158	168	177	141	150	163	174	183
		25.8	26.4	28.2	30.1	32.0	25.2	25.8	27.5	29.4	31.3	24.6	25.1	26.9	28.7	30.5	24.0	24.5	26.2	28.0	29.8	22.8	23.3	24.9	26.6	28.3	21.1	21.6	23.1	24.7	26.3
		0.87	0.82	0.67	0.50	0.33	0.90	0.85	0.69	0.52	0.35	0.93	0.87	0.71	0.53	0.36	0.96	0.90	0.73	0.55	0.37	0.99	0.93	0.76	0.57	0.40	1.00	0.94	0.76	0.57	0.40
		22	22	19	15	12	23	22	19	15	12	23	22	19	15	12	23	22	19	15	12	23	22	19	15	12	21	21	18	14	11
		1.83	1.87	1.93	2.00	2.07	1.98	2.02	2.09	2.16	2.23	2.11	2.15	2.23	2.30	2.37	2.22	2.27	2.35	2.43	2.50	2.32	2.37	2.45	2.54	2.62	2.40	2.46	2.54	2.63	2.71
		7.6	7.7	8.0	8.2	8.4	8.1	8.3	8.6	8.9	9.2	8.8	9.0	9.3	9.6	9.9	9.3	9.6	9.9	10.2	10.5	9.9	10.1	10.5	10.8	11.1	10.5	10.7	11.1	11.5	11.8
		235	253	267	278	289	263	283	299	312	324	300	322	340	355	370	341	367	388	404	420	384	413	436	455	474	424	456	482	503	524
	109	116	127	135	143	115	123	134	143	151	120	128	139	148	156	126	134	146	156	165	132	140	153	163	172	136	145	159	169	178	

NOTE: Shaded area reflects AHRI rating conditions

IDB*	Airflow	Outdoor Ambient Temperature																													
		65					75					85					95					105					115				
		59	63	67	71	75	59	63	67	71	75	59	63	67	71	75	59	63	67	71	75	59	63	67	71	75					
85	1180	29.3	29.9	31.3	33.4	35.5	28.6	29.2	30.6	32.6	34.6	27.9	28.5	29.8	31.8	33.8	27.3	27.8	29.1	31.1	33.1	25.9	26.4	27.7	29.5	31.3	24.0	24.5	25.6	27.3	29.1
		0.99	0.96	0.87	0.70	0.53	1.00	0.99	0.90	0.73	0.56	1.00	1.00	0.92	0.75	0.58	1.00	1.00	0.95	0.77	0.59	1.00	1.00	0.99	0.80	0.62	1.00	1.00	0.99	0.81	0.63
		23	22	21	18	14	22	23	21	18	14	22	22	21	18	14	21	22	22	19	15	20	21	21	18	14	19	19	19	20	17
		1.91	1.95	2.01	2.08	2.15	2.06	2.11	2.18	2.25	2.32	2.20	2.25	2.32	2.41	2.49	2.32	2.37	2.45	2.54	2.62	2.42	2.48	2.56	2.65	2.73	2.51	2.57	2.66	2.75	2.83
		7.9	8.1	8.3	8.6	8.8	8.5	8.7	8.9	9.3	9.6	9.2	9.4	9.7	10.0	10.3	9.8	10.0	10.3	10.7	11.0	10.4	10.6	10.9	11.3	11.6	10.9	11.2	11.6	12.0	12.3
		247	266	281	293	304	277	298	315	328	340	315	339	358	373	388	359	386	408	425	440	404	434	459	478	497	446	480	507	529	551
		115	122	133	142	149	121	129	141	150	158	126	134	146	156	164	132	141	154	164	172	139	148	161	172	180	144	153	167	178	187
		28.5	29.0	30.4	32.4	34.4	27.8	28.3	29.7	31.7	33.7	27.1	27.7	29.0	30.9	32.8	26.5	27.0	28.3	30.1	31.9	25.1	25.6	26.8	28.6	30.4	23.3	23.7	24.9	26.5	28.1
		0.95	0.91	0.83	0.67	0.50	0.98	0.95	0.86	0.69	0.52	1.00	0.97	0.88	0.71	0.54	1.00	1.00	0.91	0.73	0.55	1.00	1.00	0.94	0.76	0.58	1.00	1.00	0.95	0.77	0.59
		24	23	22	19	15	24	24	22	19	15	24	24	22	19	15	23	24	22	19	15	22	22	22	19	15	20	21	21	18	14
1050		1.89	1.93	2.00	2.07	2.14	2.04	2.09	2.16	2.23	2.30	2.18	2.23	2.30	2.38	2.45	2.30	2.35	2.43	2.52	2.60	2.40	2.46	2.54	2.63	2.71	2.49	2.55	2.63	2.73	2.81
		7.8	8.0	8.2	8.5	8.8	8.4	8.6	8.9	9.2	9.5	9.1	9.3	9.6	9.9	10.2	9.7	9.9	10.2	10.6	11.0	10.3	10.5	10.8	11.2	11.5	10.9	11.1	11.5	11.9	12.2
		244	263	278	290	302	274	295	312	325	337	312	336	354	370	385	355	382	404	421	438	400	430	454	474	494	442	475	502	523	544
		114	121	132	141	149	120	128	139	149	158	125	133	145	154	162	131	139	152	162	170	137	146	160	170	179	142	151	165	176	185
		28.0	28.6	30.5	32.6	34.7	27.3	27.9	29.8	31.9	34.0	26.7	27.2	29.1	31.1	33.1	26.0	26.6	28.4	30.4	32.4	24.7	25.3	27.0	28.8	30.6	22.9	23.4	25.0	26.7	28.4
		0.90	0.85	0.69	0.52	0.35	0.94	0.88	0.72	0.53	0.35	0.96	0.90	0.73	0.55	0.37	0.99	0.93	0.76	0.57	0.39	1.00	0.97	0.79	0.59	0.41	1.00	0.97	0.79	0.59	0.41
		22	21	18	15	12	22	21	19	15	12	22	21	19	15	12	23	22	19	15	12	22	21	19	15	12	20	20	17	14	11
		1.88	1.92	1.98	2.05	2.12	2.03	2.07	2.14	2.22	2.29	2.16	2.21	2.29	2.36	2.43	2.28	2.33	2.41	2.49	2.56	2.38	2.43	2.52	2.61	2.69	2.47	2.52	2.61	2.70	2.78
		7.8	7.9	8.2	8.5	8.8	8.3	8.5	8.8	9.1	9.4	9.0	9.2	9.5	9.8	10.1	9.6	9.8	10.1	10.5	10.9	10.2	10.4	10.7	11.1	11.4	10.8	11.0	11.4	11.8	12.1
		242	260	275	287	299	272	292	309	322	334	309	332	351	366	381	352	379	400	417	433	396	426	450	469	487	437	470	497	518	536
	113	120	131	139	147	119	126	138	147	154	124	131	144	153	161	130	138	151	161	170	136	145	158	168	177	141	150	163	174	183	

# COOLING PERFORMANCE DATA

# GPC1436H41AA

MODEL: GPC1436H41A\*

EXPANDED PERFORMANCE DATA

COOLING OPERATION

IDB*	Airflow	Outdoor Ambient Temperature																							
		65				75				85				95				105				115			
		59	63	67	71	59	63	67	71	59	63	67	71	59	63	67	71	59	63	67	71	59	63	67	71
70	MBh	34.9	36.2	39.6	-	34.1	35.3	38.7	-	33.3	34.5	37.8	-	32.5	33.6	36.9	-	30.8	32.0	35.0	-	28.6	29.6	32.4	-
	S/T	0.76	0.64	0.44	-	0.79	0.66	0.46	-	0.81	0.68	0.47	-	0.84	0.70	0.48	-	0.87	0.72	0.50	-	0.87	0.73	0.51	-
	Delta T	18	16	12	-	18	16	12	-	18	16	12	-	18	16	12	-	18	16	12	-	17	15	11	-
	KW	2.33	2.38	2.45	-	2.51	2.57	2.65	-	2.67	2.73	2.82	-	2.81	2.88	2.97	-	2.93	3.00	3.10	-	3.04	3.11	3.21	-
	AMPS	10.5	10.8	11.0	-	11.3	11.5	11.8	-	12.1	12.3	12.7	-	12.8	13.1	13.4	-	13.5	13.8	14.2	-	14.2	14.5	14.9	-
	HI PR	238	256	271	-	267	288	304	-	304	327	345	-	346	372	393	-	389	419	442	-	430	463	489	-
	LO PR	107	114	125	-	114	121	132	-	118	126	137	-	124	132	144	-	130	138	151	-	134	143	156	-
	MBh	33.9	35.1	38.5	-	33.1	34.3	37.6	-	32.3	33.5	36.7	-	31.5	32.7	35.8	-	29.9	31.0	34.0	-	27.7	28.7	31.5	-
	S/T	0.73	0.61	0.42	-	0.75	0.63	0.44	-	0.77	0.64	0.45	-	0.80	0.67	0.46	-	0.83	0.69	0.48	-	0.83	0.70	0.48	-
	Delta T	19	16	12	-	19	17	13	-	19	17	13	-	19	17	13	-	19	16	12	-	18	15	12	-
1200	KW	2.31	2.36	2.43	-	2.49	2.54	2.63	-	2.65	2.71	2.80	-	2.79	2.85	2.95	-	2.91	2.97	3.07	-	3.01	3.08	3.18	-
	AMPS	10.5	10.7	11.0	-	11.2	11.4	11.7	-	12.0	12.2	12.6	-	12.7	12.9	13.3	-	13.4	13.7	14.1	-	14.1	14.4	14.8	-
	HI PR	236	254	268	-	265	285	301	-	301	324	342	-	343	369	389	-	386	415	438	-	426	458	484	-
	LO PR	106	113	124	-	112	120	131	-	117	124	136	-	123	131	143	-	129	137	149	-	133	142	155	-
	MBh	31.3	32.4	35.5	-	30.5	31.6	34.7	-	29.8	30.9	33.8	-	29.1	30.1	33.0	-	27.6	28.6	31.4	-	25.6	26.5	29.1	-
	S/T	0.70	0.58	0.41	-	0.73	0.61	0.42	-	0.74	0.62	0.43	-	0.77	0.64	0.44	-	0.80	0.67	0.46	-	0.80	0.67	0.47	-
	Delta T	19	17	13	-	19	17	13	-	19	17	13	-	20	17	13	-	19	17	13	-	18	16	12	-
	KW	2.25	2.30	2.37	-	2.43	2.48	2.56	-	2.58	2.64	2.73	-	2.72	2.78	2.87	-	2.84	2.90	3.00	-	2.94	3.00	3.10	-
	AMPS	10.2	10.4	10.7	-	10.9	11.1	11.4	-	11.7	11.9	12.3	-	12.4	12.6	13.0	-	13.1	13.3	13.7	-	13.7	14.0	14.4	-
	HI PR	229	246	260	-	257	276	292	-	292	314	332	-	332	358	378	-	374	402	425	-	413	445	470	-
LO PR	103	110	120	-	109	116	127	-	113	121	132	-	119	127	138	-	125	133	145	-	129	137	150	-	
75	MBh	35.5	36.5	39.5	42.4	34.7	35.7	38.6	41.4	33.8	34.8	37.7	40.5	33.0	34.0	36.8	39.5	31.4	32.3	34.9	37.5	29.0	29.9	32.4	34.7
	S/T	0.87	0.77	0.59	0.38	0.90	0.80	0.61	0.39	0.92	0.82	0.62	0.40	0.95	0.85	0.64	0.41	0.99	0.88	0.67	0.43	0.99	0.89	0.67	0.43
	Delta T	21	19	16	11	21	20	16	11	21	20	16	11	21	20	16	11	21	19	16	11	20	18	15	10
	KW	2.35	2.40	2.47	2.56	2.53	2.59	2.67	2.76	2.69	2.75	2.84	2.94	2.84	2.90	3.00	3.10	2.96	3.03	3.13	3.24	3.06	3.13	3.24	3.35
	AMPS	10.6	10.8	11.1	11.5	11.3	11.6	11.9	12.3	12.2	12.4	12.8	13.2	12.9	13.2	13.5	14.0	13.6	13.9	14.3	14.8	14.3	14.6	15.1	15.6
	HI PR	241	259	273	285	270	290	307	320	307	330	349	364	350	376	397	414	393	423	447	466	435	468	494	515
	LO PR	109	116	126	134	115	122	133	142	119	127	138	147	125	133	145	155	131	140	152	162	136	144	158	168
	MBh	34.4	35.5	38.4	41.2	33.6	34.6	37.5	40.2	32.8	33.8	36.6	39.3	32.0	33.0	35.7	38.3	30.4	31.3	33.9	36.4	28.2	29.0	31.4	33.7
	S/T	0.83	0.74	0.56	0.36	0.86	0.77	0.58	0.37	0.88	0.78	0.59	0.38	0.91	0.81	0.61	0.39	0.94	0.84	0.64	0.41	0.95	0.85	0.64	0.41
	Delta T	22	20	16	11	22	20	17	11	22	20	17	11	22	20	17	11	22	20	17	11	20	19	15	11
1200	KW	2.33	2.38	2.45	2.54	2.51	2.57	2.65	2.74	2.67	2.73	2.82	2.92	2.81	2.88	2.97	3.07	2.93	3.00	3.10	3.21	3.04	3.11	3.21	3.32
	AMPS	10.5	10.8	11.0	11.4	11.3	11.5	11.8	12.2	12.1	12.3	12.7	13.1	12.8	13.1	13.4	13.9	13.5	13.8	14.2	14.7	14.2	14.5	14.9	15.4
	HI PR	238	256	271	282	267	288	304	317	304	327	345	360	346	373	393	410	389	419	443	462	430	463	489	510
	LO PR	107	114	125	133	114	121	132	140	118	126	137	146	124	132	144	153	130	138	151	161	134	143	156	166
	MBh	31.8	32.7	35.4	38.0	31.1	32.0	34.6	37.1	30.3	31.2	33.8	36.3	29.6	30.4	33.0	35.4	28.1	28.9	31.3	33.6	26.0	26.8	29.0	31.1
	S/T	0.80	0.71	0.54	0.35	0.83	0.74	0.56	0.36	0.85	0.76	0.57	0.37	0.87	0.78	0.59	0.38	0.91	0.81	0.61	0.39	0.91	0.82	0.62	0.40
	Delta T	22	20	17	12	22	21	17	12	22	21	17	12	23	21	17	12	22	21	17	12	21	19	16	11
	KW	2.27	2.32	2.39	2.47	2.45	2.50	2.58	2.67	2.60	2.66	2.75	2.84	2.74	2.80	2.90	2.99	2.86	2.92	3.02	3.12	2.96	3.03	3.13	3.24
	AMPS	10.3	10.5	10.8	11.1	11.0	11.2	11.5	11.9	11.8	12.0	12.4	12.8	12.5	12.7	13.1	13.5	13.2	13.4	13.8	14.3	13.8	14.1	14.6	15.0
	HI PR	231	249	263	274	259	279	295	307	295	317	335	349	336	361	382	398	378	407	429	448	417	449	474	495
LO PR	104	111	121	129	110	117	128	136	114	122	133	142	120	128	140	149	126	134	146	156	130	139	151	161	

\* IDB: Entering Indoor Dry Bulb Temperature

High and low pressures are measured at the liquid and suction access fittings.

NOTE: Shaded area is ACCA (TVA) conditions

# COOLING PERFORMANCE DATA

# GPC1436H41AA

IDB*	Airflow	Outdoor Ambient Temperature																																																																																																																																																																																																																																																																																																																																																																																																																																																																																																																							
		65					75					85					95					105					115																																																																																																																																																																																																																																																																																																																																																																																																																																																																																														
		59	63	67	71	75	59	63	67	71	75	59	63	67	71	75	59	63	67	71	75	59	63	67	71	75	59	63	67	71	75																																																																																																																																																																																																																																																																																																																																																																																																																																																																																										
80	1349	36.1	36.9	39.4	42.1	35.3	36.0	38.5	41.2	34.4	35.2	37.6	40.2	33.6	34.3	36.7	39.2	31.9	32.6	34.8	37.2	29.6	30.2	32.3	34.5	0.95	0.89	0.72	0.54	1.00	0.92	0.75	0.56	1.00	0.95	0.77	0.58	1.00	1.00	0.80	0.59	1.00	1.00	0.83	0.62	1.00	1.00	0.83	0.62	2.3	2.2	1.9	1.6	2.4	2.3	2.0	1.6	2.3	2.3	2.0	1.6	2.2	2.2	2.0	1.6	2.2	2.2	2.0	1.6	2.0	2.1	1.8	1.5	2.37	2.42	2.50	2.58	2.55	2.61	2.69	2.78	2.72	2.78	2.87	2.97	2.86	2.93	3.02	3.13	2.98	3.05	3.15	3.26	3.09	3.16	3.27	3.38	10.7	10.9	11.2	11.6	11.4	11.7	12.0	12.4	12.3	12.5	12.9	13.3	13.0	13.3	13.6	14.1	13.7	14.0	14.4	14.9	14.4	14.7	15.2	15.7	243	261	276	288	273	293	310	323	310	334	352	368	353	380	401	419	397	428	451	471	439	472	499	520	110	117	127	136	116	123	135	143	120	128	140	149	126	135	147	156	133	141	154	164	137	146	159	170	35.1	35.8	38.3	40.9	34.2	35.0	37.4	40.0	33.4	34.2	36.5	39.0	32.6	33.3	<b>35.6</b>	<b>38.1</b>	31.0	31.7	33.8	36.2	28.7	29.3	31.3	33.5	0.91	0.85	0.69	0.52	0.94	0.88	0.72	0.54	0.96	0.90	0.73	0.55	0.99	0.93	<b>0.76</b>	<b>0.57</b>	1.00	0.97	0.79	0.59	1.00	0.97	0.79	0.59	24	23	20	16	25	24	21	16	25	24	21	16	25	24	<b>21</b>	<b>17</b>	24	23	20	16	22	22	19	15	2.35	2.40	2.48	2.56	2.53	2.59	2.67	2.76	2.69	2.75	2.84	2.94	2.84	2.90	<b>3.00</b>	<b>3.10</b>	2.96	3.03	3.13	3.24	3.06	3.13	3.24	3.35	10.6	10.8	11.1	11.5	11.3	11.6	11.9	12.3	12.2	12.4	12.8	13.2	12.9	13.2	<b>13.5</b>	<b>14.0</b>	13.6	13.9	14.3	14.8	14.3	14.6	15.1	15.6	241	259	273	285	270	290	307	320	307	330	349	364	350	376	<b>397</b>	<b>414</b>	393	423	447	466	435	468	494	515	109	116	126	134	115	122	133	142	119	127	138	147	125	133	<b>145</b>	<b>155</b>	131	140	152	162	136	144	158	168	32.4	33.1	35.3	37.8	31.6	32.3	34.5	36.9	30.9	31.5	33.7	36.0	30.1	30.8	32.9	35.1	28.6	29.2	31.2	33.4	26.5	27.1	28.9	30.9	0.87	0.82	0.67	0.50	0.90	0.85	0.69	0.52	0.93	0.87	0.71	0.53	0.96	0.90	0.73	0.55	0.99	0.93	0.76	0.57	1.00	0.94	0.77	0.57	25	24	21	16	25	24	21	17	25	24	21	17	25	24	<b>21</b>	<b>17</b>	25	24	21	17	23	22	19	15	2.29	2.34	2.41	2.49	2.47	2.52	2.60	2.69	2.63	2.68	2.77	2.87	2.77	2.83	2.92	3.02	2.88	2.95	3.05	3.15	2.99	3.05	3.16	3.26	10.4	10.6	10.9	11.2	11.1	11.3	11.6	12.0	11.9	12.1	12.5	12.9	12.6	12.8	13.2	13.6	13.3	13.6	14.0	14.4	14.0	14.3	14.7	15.2	233	251	265	277	262	282	298	310	298	320	338	353	339	365	385	402	382	411	434	452	422	454	479	500	105	112	122	130	111	118	129	138	116	123	134	143	121	129	141	150	127	135	148	157	132	140	153	163

NOTE: Shaded area reflects AHRI rating conditions

IDB*	Airflow	Outdoor Ambient Temperature																																																																																																																																																																																																																																																																																																																																																																																																																																																																																																																							
		65					75					85					95					105					115																																																																																																																																																																																																																																																																																																																																																																																																																																																																																														
		59	63	67	71	75	59	63	67	71	75	59	63	67	71	75	59	63	67	71	75	59	63	67	71	75	59	63	67	71	75																																																																																																																																																																																																																																																																																																																																																																																																																																																																																										
85	1349	36.7	37.4	39.2	41.8	35.9	36.6	38.3	40.9	35.0	35.7	37.4	39.9	34.2	34.8	36.5	38.9	32.5	33.1	34.7	37.0	30.1	30.7	32.1	34.3	1.00	0.96	0.87	0.70	1.00	1.00	0.90	0.73	1.00	1.00	0.92	0.75	1.00	1.00	0.95	0.77	1.00	1.00	0.99	0.80	1.00	1.00	0.83	0.62	25	25	23	20	24	25	23	20	24	24	23	20	23	24	24	20	22	23	23	20	21	21	22	19	2.39	2.44	2.52	2.60	2.57	2.63	2.72	2.81	2.74	2.80	2.89	2.99	2.89	2.95	3.05	3.15	3.01	3.08	3.18	3.29	3.12	3.19	3.30	3.41	10.8	11.0	11.3	11.7	11.5	11.8	12.1	12.5	12.4	12.6	13.0	13.4	13.1	13.4	13.8	14.2	13.8	14.1	14.5	15.0	14.5	14.9	15.3	15.8	245	264	279	291	275	296	313	326	313	337	356	371	357	384	405	423	401	432	456	476	443	477	504	525	111	118	129	137	117	124	136	145	122	129	141	150	128	136	148	158	134	142	155	166	138	147	161	171	35.7	36.4	38.1	40.6	34.8	35.5	37.2	39.7	34.0	34.7	36.3	38.7	33.2	33.8	35.4	37.8	31.5	32.1	33.7	35.9	29.2	29.8	31.2	33.3	0.95	0.92	0.83	0.67	0.98	0.95	0.86	0.70	1.00	0.97	0.88	0.71	1.00	1.00	0.91	0.74	1.00	1.00	0.94	0.76	1.00	1.00	0.95	0.77	26	26	24	21	26	26	24	21	26	26	24	21	25	26	25	21	24	25	24	21	22	23	23	20	2.37	2.42	2.50	2.58	2.55	2.61	2.69	2.78	2.72	2.78	2.87	2.97	2.86	2.93	3.02	3.13	2.98	3.05	3.15	3.26	3.09	3.16	3.27	3.38	10.7	10.9	11.2	11.6	11.4	11.7	12.0	12.4	12.3	12.5	12.9	13.3	13.0	13.3	13.6	14.1	13.7	14.0	14.4	14.9	14.4	14.7	15.2	15.7	243	261	276	288	273	293	310	323	310	334	352	368	353	380	401	419	397	428	451	471	439	472	499	520	110	117	127	136	116	123	135	143	120	128	140	149	126	135	147	156	133	141	154	164	137	146	159	170	32.9	33.6	35.1	37.5	32.2	32.8	34.3	36.6	31.4	32.0	33.5	35.8	30.6	31.2	32.7	34.9	29.1	29.7	31.1	33.1	26.9	27.5	28.8	30.7	0.92	0.88	0.80	0.65	0.95	0.92	0.83	0.67	0.97	0.94	0.85	0.69	1.00	0.97	0.87	0.71	1.00	1.00	0.91	0.74	1.00	1.00	0.92	0.74	26	26	24	21	27	26	25	21	27	26	25	21	27	26	25	22	25	26	25	21	24	24	23	20	2.31	2.36	2.43	2.51	2.49	2.54	2.63	2.71	2.65	2.71	2.80	2.89	2.79	2.85	2.95	3.05	2.91	2.97	3.07	3.18	3.01	3.08	3.18	3.29	10.5	10.7	11.0	11.3	11.2	11.4	11.7	12.1	12.0	12.2	12.6	13.0	12.7	12.9	13.3	13.8	13.4	13.7	14.1	14.5	14.1	14.4	14.8	15.3	236	254	268	279	264	285	301	313	301	324	342	356	343	369	389	406	385	415	438	457	426	458	484	505	106	113	124	132	112	120	131	139	117	124	136	144	123	131	142	152	129	137	149	159	133	141	154	165

\* NOTE: Shaded areas is AHRI Rating Conditions IDB: Entering Indoor Dry Bulb Temperature KW = Total system power High and low pressures are measured at the liquid and suction access fittings. AMPS: Unit amps (comp.+ evaporator + condenser fan motors)

# COOLING PERFORMANCE DATA

# GPC1442H41AA

## EXPANDED PERFORMANCE DATA

## EXPANDED PERFORMANCE DATA

## MODEL: GPC1442H41A\*

## COOLING OPERATION

IDB*	Airflow	Outdoor Ambient Temperature																													
		65					75					85					95					105					115				
		59	63	67	71	75	59	63	67	71	75	59	63	67	71	75	59	63	67	71	75	59	63	67	71	75	59	63	67	71	75
70	MBh	39.7	41.1	45.1	-	38.8	40.2	44.0	-	37.8	39.2	43.0	-	36.9	38.3	41.9	-	35.1	36.4	39.8	-	32.5	33.7	36.9	-						
	S/T	0.75	0.63	0.43	-	0.78	0.65	0.45	-	0.80	0.67	0.46	-	0.82	0.69	0.48	-	0.86	0.71	0.49	-	0.86	0.72	0.50	-						
	Delta T	19	16	12	-	19	16	12	-	19	16	12	-	19	17	13	-	19	16	12	-	18	15	12	-						
	KW	2.54	2.60	2.68	-	2.74	2.80	2.89	-	2.92	2.98	3.08	-	3.07	3.14	3.25	-	3.21	3.28	3.39	-	3.32	3.40	3.51	-						
	A/MPS	11.6	11.8	12.1	-	12.4	12.6	13.0	-	13.3	13.6	14.0	-	14.1	14.4	14.9	-	14.9	15.3	15.7	-	15.7	16.1	16.6	-						
	H/PR	236	254	268	-	265	285	301	-	301	324	342	-	343	369	390	-	386	415	439	-	426	459	485	-						
	LO PR	110	116	127	-	116	123	134	-	120	128	140	-	126	134	147	-	132	141	154	-	137	146	159	-						
	MBh	38.5	39.9	43.8	-	37.6	39.0	42.7	-	36.7	38.1	41.7	-	35.8	37.1	40.7	-	34.1	35.3	38.7	-	31.5	32.7	35.8	-						
	S/T	0.72	0.60	0.41	-	0.74	0.62	0.43	-	0.76	0.64	0.44	-	0.79	0.66	0.45	-	0.82	0.68	0.47	-	0.82	0.69	0.48	-						
	Delta T	20	17	13	-	20	17	13	-	20	17	13	-	20	17	13	-	20	17	13	-	18	16	12	-						
1300	KW	2.52	2.58	2.66	-	2.72	2.78	2.87	-	2.89	2.96	3.06	-	3.05	3.12	3.22	-	3.18	3.25	3.36	-	3.29	3.37	3.48	-						
	A/MPS	11.5	11.7	12.0	-	12.3	12.5	12.9	-	13.2	13.5	13.9	-	14.0	14.3	14.7	-	14.8	15.1	15.6	-	15.6	15.9	16.4	-						
	H/PR	234	251	266	-	262	282	298	-	298	321	339	-	340	366	386	-	382	411	434	-	422	454	480	-						
	LO PR	108	115	126	-	115	122	133	-	119	127	138	-	125	133	145	-	131	139	152	-	136	144	157	-						
	MBh	35.6	36.9	40.4	-	34.7	36.0	39.4	-	33.9	35.1	38.5	-	33.1	34.3	37.6	-	31.4	32.6	35.7	-	29.1	30.2	33.1	-						
	S/T	0.69	0.58	0.40	-	0.72	0.60	0.41	-	0.73	0.61	0.42	-	0.76	0.63	0.44	-	0.79	0.66	0.46	-	0.79	0.66	0.46	-						
	Delta T	20	17	13	-	20	17	13	-	20	17	13	-	20	18	13	-	20	17	13	-	19	16	12	-						
	KW	2.46	2.51	2.59	-	2.65	2.71	2.80	-	2.82	2.88	2.98	-	2.97	3.04	3.14	-	3.10	3.17	3.27	-	3.21	3.28	3.39	-						
	A/MPS	11.2	11.4	11.8	-	12.0	12.2	12.6	-	12.9	13.2	13.5	-	13.7	14.0	14.4	-	14.4	14.8	15.2	-	15.2	15.5	16.0	-						
	H/PR	227	244	258	-	254	274	289	-	289	311	329	-	329	355	374	-	371	399	421	-	410	441	465	-						
LO PR	105	112	122	-	111	118	129	-	115	123	134	-	121	129	141	-	127	135	148	-	131	140	153	-							

1461	MBh	40.4	41.6	45.0	48.3	39.4	40.6	43.9	47.2	38.5	39.6	42.9	46.0	37.5	38.7	41.8	44.9	35.7	36.7	39.7	42.7	33.0	34.0	36.8	39.5	
	S/T	0.85	0.76	0.58	0.37	0.88	0.79	0.60	0.39	0.91	0.81	0.61	0.40	0.94	0.84	0.63	0.41	0.97	0.87	0.66	0.42	0.98	0.88	0.66	0.43	
	Delta T	22	20	16	11	22	20	17	11	22	20	17	11	22	20	17	12	22	20	16	11	20	19	15	11	
	KW	2.56	2.62	2.70	2.79	2.77	2.83	2.92	3.02	3.02	2.94	3.01	3.11	3.21	3.10	3.17	3.28	3.39	3.23	3.31	3.42	3.54	3.35	3.43	3.54	3.66
	A/MPS	11.7	11.9	12.2	12.6	12.5	12.7	13.1	13.5	13.4	13.7	14.1	14.6	14.6	14.2	14.5	15.0	15.5	15.1	15.4	15.8	16.4	15.9	16.2	16.7	17.3
	H/PR	238	257	271	283	268	288	304	317	304	327	346	361	347	347	373	394	411	390	420	443	462	431	464	490	511
	LO PR	111	118	128	137	117	124	136	145	121	129	141	150	128	136	148	158	158	134	142	155	165	138	147	161	171
	MBh	39.2	40.3	43.7	46.9	38.3	39.4	42.7	45.8	37.4	38.5	41.6	44.7	36.5	37.5	40.6	43.6	34.6	35.7	38.6	41.4	32.1	33.0	35.7	38.4	
	S/T	0.81	0.73	0.55	0.35	0.84	0.75	0.57	0.37	0.87	0.77	0.59	0.38	0.89	0.80	0.60	0.39	0.93	0.83	0.63	0.40	0.93	0.84	0.63	0.41	
	Delta T	23	21	17	12	23	21	17	12	23	21	17	12	23	21	17	12	23	21	17	12	21	20	16	11	
75	KW	2.54	2.60	2.68	2.77	2.74	2.80	2.89	2.99	2.92	2.98	3.08	3.19	3.07	3.14	3.25	3.36	3.21	3.28	3.39	3.51	3.32	3.40	3.51	3.63	
	A/MPS	11.6	11.8	12.1	12.5	12.4	12.6	13.0	13.4	13.3	13.6	14.0	14.5	14.1	14.4	14.9	15.4	14.9	15.3	15.7	16.3	15.7	16.1	16.6	17.1	
	H/PR	236	254	268	280	265	285	301	314	301	324	342	357	343	369	390	407	386	415	439	458	427	459	485	506	
	LO PR	110	117	127	135	116	123	134	143	120	128	140	149	126	134	147	156	132	141	154	164	137	146	159	169	
	MBh	36.2	37.2	40.3	43.3	35.3	36.4	39.4	42.3	34.5	35.5	38.4	41.2	33.6	34.6	37.5	40.2	32.0	32.9	35.6	38.2	29.6	30.5	33.0	35.4	
	S/T	0.79	0.70	0.53	0.34	0.81	0.73	0.55	0.35	0.83	0.75	0.56	0.36	0.86	0.77	0.58	0.38	0.89	0.80	0.61	0.39	0.90	0.81	0.61	0.39	
	Delta T	23	21	17	12	23	21	18	12	23	21	18	12	23	22	18	12	23	21	17	12	22	20	16	11	
	KW	2.48	2.53	2.62	2.70	2.67	2.73	2.82	2.92	2.85	2.91	3.00	3.11	3.00	3.06	3.17	3.27	3.13	3.20	3.30	3.42	3.24	3.31	3.42	3.54	
	A/MPS	11.3	11.5	11.9	12.2	12.1	12.3	12.7	13.1	13.0	13.3	13.7	14.1	13.8	14.1	14.5	15.0	14.6	14.9	15.3	15.8	15.3	15.7	16.1	16.7	
	H/PR	229	246	260	271	257	277	292	305	292	314	332	346	333	358	378	394	374	403	425	444	414	445	470	490	
LO PR	106	113	123	131	112	119	130	139	117	124	135	144	123	130	142	152	128	137	149	159	133	141	154	164		

\* IDB: Entering Indoor Dry Bulb Temperature

NOTE: Shaded area is ACCA (TVA) conditions  
High and low pressures are measured at the liquid and suction access fittings.



# COOLING PERFORMANCE DATA

# GPC1442H41AA

IDB*	Airflow	Outdoor Ambient Temperature																													
		65					75					85					95					105					115				
		59	63	67	71	75	59	63	67	71	75	59	63	67	71	75	59	63	67	71	75	59	63	67	71	75	59	63	67	71	75
1461	MBh	41.1	42.0	44.8	47.9	40.1	41.0	43.8	46.8	39.2	40.0	42.8	45.7	38.2	39.0	41.7	44.6	36.3	37.1	39.6	42.4	33.6	34.4	36.7	39.2						
	S/T	0.94	0.88	0.71	0.53	0.97	0.91	0.74	0.55	1.00	0.93	0.76	0.57	1.00	0.96	0.78	0.59	1.00	1.00	0.81	0.61	1.00	1.00	0.82	0.61						
	Delta T	24	23	20	16	25	23	20	16	25	24	20	16	24	24	21	16	23	23	20	16	21	22	19	15						
	KW	2.58	2.64	2.73	2.82	2.79	2.85	2.94	3.04	2.97	3.03	3.14	3.24	3.13	3.20	3.30	3.42	3.26	3.34	3.45	3.57	3.38	3.46	3.57	3.70						
	AMPS	11.8	12.0	12.3	12.7	12.6	12.8	13.2	13.6	13.5	13.8	14.2	14.7	14.4	14.7	15.1	15.6	15.2	15.5	16.0	16.5	16.0	16.3	16.8	17.4						
	HI PR	241	259	274	285	270	291	307	320	307	331	349	364	350	377	398	415	394	424	448	467	435	468	494	516						
	LO PR	112	119	130	138	118	126	137	146	123	131	142	152	129	137	150	159	135	144	157	167	140	149	162	173						
	MBh	39.9	40.8	43.5	46.5	39.0	39.8	42.5	45.5	38.0	38.9	41.5	44.4	37.1	37.9	40.5	43.3	35.2	36.0	38.5	41.1	32.6	33.4	35.6	38.1						
	S/T	0.89	0.84	0.68	0.51	0.93	0.87	0.71	0.53	0.95	0.89	0.72	0.54	0.98	0.92	0.75	0.56	1.00	0.95	0.78	0.58	1.00	0.96	0.78	0.59						
	Delta T	25	24	21	17	25	24	21	17	26	24	21	17	26	25	22	17	25	24	21	17	23	23	20	16						
KW	2.56	2.62	2.70	2.79	2.77	2.83	2.92	3.02	2.94	3.01	3.11	3.21	3.10	3.17	3.28	3.39	3.23	3.31	3.42	3.54	3.35	3.43	3.54	3.67							
AMPS	11.7	11.9	12.2	12.6	12.5	12.7	13.1	13.5	13.4	13.7	14.1	14.6	14.2	14.5	15.0	15.5	15.1	15.4	15.8	16.4	15.9	16.2	16.7	17.3							
HI PR	238	257	271	283	268	288	304	317	304	327	346	361	347	373	394	411	390	420	443	462	431	464	490	511							
LO PR	111	118	128	137	117	124	136	145	121	129	141	150	128	136	148	158	134	142	155	165	138	147	161	171							
1300	MBh	36.8	37.6	40.2	43.0	36.0	36.7	39.3	42.0	35.1	35.9	38.3	41.0	34.2	35.0	37.4	40.0	32.5	33.2	35.5	38.0	30.1	30.8	32.9	35.2						
	S/T	0.86	0.81	0.66	0.49	0.89	0.84	0.68	0.51	0.92	0.86	0.70	0.52	0.94	0.89	0.72	0.54	0.98	0.92	0.75	0.56	0.99	0.93	0.75	0.56						
	Delta T	26	25	21	17	26	25	22	17	26	25	22	17	26	25	22	17	26	25	21	17	24	23	20	16						
	KW	2.50	2.56	2.64	2.72	2.70	2.76	2.85	2.94	2.87	2.93	3.03	3.13	3.02	3.09	3.19	3.30	3.15	3.22	3.33	3.45	3.26	3.34	3.45	3.57						
	AMPS	11.4	11.6	12.0	12.3	12.2	12.4	12.8	13.2	13.1	13.4	13.8	14.2	13.9	14.2	14.6	15.1	14.7	15.0	15.4	16.0	15.5	15.8	16.3	16.8						
	HI PR	231	249	263	274	260	279	295	308	295	318	335	350	336	362	382	398	378	407	430	448	418	450	475	495						
	LO PR	107	114	125	133	113	121	132	140	118	125	137	146	124	132	144	153	130	138	151	160	134	143	156	166						
	1139	MBh	41.8	42.6	44.6	47.6	40.8	41.6	43.6	46.5	39.9	40.6	42.5	45.4	38.9	39.6	41.5	44.3	36.9	37.6	39.4	42.1	34.2	34.9	36.5	39.0					
		S/T	0.98	0.95	0.85	0.69	1.00	0.98	0.89	0.72	1.00	1.00	0.91	0.74	1.00	1.00	0.94	0.76	1.00	1.00	0.97	0.79	1.00	1.00	0.98	0.80					
		Delta T	26	25	24	21	26	26	24	21	25	26	24	21	24	25	24	21	23	24	24	21	22	22	23	20					
KW		2.61	2.66	2.75	2.84	2.81	2.87	2.97	3.07	2.99	3.06	3.16	3.27	3.15	3.22	3.33	3.45	3.29	3.36	3.48	3.60	3.41	3.49	3.60	3.73						
AMPS		11.8	12.1	12.4	12.8	12.7	12.9	13.3	13.8	13.6	13.9	14.3	14.8	14.5	14.8	15.2	15.7	15.3	15.6	16.1	16.7	16.1	16.5	17.0	17.6						
HI PR		243	262	276	288	273	294	310	324	310	334	353	368	354	380	402	419	398	428	452	471	439	473	499	521						
LO PR		113	120	131	140	119	127	138	147	124	132	144	153	130	138	151	161	136	145	158	169	141	150	164	175						
MBh		40.6	41.4	43.3	46.2	39.6	40.4	42.3	45.1	38.7	39.4	41.3	44.1	37.7	38.5	40.3	43.0	35.9	36.6	38.3	40.8	33.2	33.9	35.5	37.8						
S/T		0.94	0.90	0.82	0.66	0.97	0.94	0.85	0.69	1.00	0.96	0.87	0.70	1.00	0.99	0.89	0.73	1.00	1.00	0.93	0.75	1.00	1.00	0.94	0.76						
Delta T		27	26	25	22	27	27	25	22	27	27	25	22	27	27	25	22	25	26	25	22	23	24	23	20						
KW	2.58	2.64	2.73	2.82	2.79	2.85	2.94	3.04	2.97	3.03	3.14	3.24	3.13	3.20	3.30	3.42	3.26	3.34	3.45	3.57	3.38	3.46	3.57	3.70							
AMPS	11.8	12.0	12.3	12.7	12.6	12.8	13.2	13.6	13.5	13.8	14.2	14.7	14.4	14.7	15.1	15.6	15.2	15.5	16.0	16.5	16.0	16.3	16.8	17.4							
HI PR	241	259	274	285	270	291	307	320	307	331	349	364	350	377	398	415	394	424	448	467	435	468	494	516							
LO PR	112	119	130	138	118	126	137	146	123	131	142	152	129	137	150	159	135	144	157	167	140	149	162	173							
85	MBh	37.5	38.2	40.0	42.7	36.6	37.3	39.1	41.7	35.7	36.4	38.1	40.7	34.8	35.5	37.2	39.7	33.1	33.7	35.3	37.7	30.7	31.3	32.7	34.9						
	S/T	0.90	0.87	0.79	0.64	0.94	0.90	0.81	0.66	0.96	0.93	0.84	0.68	0.99	0.96	0.86	0.70	1.00	0.99	0.90	0.73	1.00	1.00	0.90	0.73						
	Delta T	27	27	25	22	28	27	26	22	28	27	26	22	28	27	26	22	27	27	26	22	25	25	24	21						
	KW	2.52	2.58	2.66	2.75	2.72	2.78	2.87	2.97	2.89	2.96	3.06	3.16	3.05	3.12	3.22	3.33	3.18	3.25	3.36	3.48	3.29	3.37	3.48	3.60						
	AMPS	11.5	11.7	12.0	12.4	12.3	12.5	12.9	13.3	13.2	13.5	13.9	14.3	14.0	14.3	14.7	15.2	14.8	15.1	15.6	16.1	15.6	15.9	16.4	17.0						
	HI PR	234	251	265	277	262	282	298	311	298	321	339	353	340	365	386	402	382	411	434	453	422	454	480	500						
	LO PR	108	115	126	134	115	122	133	142	119	127	138	147	125	133	145	155	131	139	152	162	136	144	157	168						

NOTE: Shaded area reflects AHRI rating conditions

IDB*	Airflow	Outdoor Ambient Temperature																													
		65					75					85					95					105					115				
		59	63	67	71	75	59	63	67	71	75	59	63	67	71	75	59	63	67	71	75	59	63	67	71	75	59	63	67	71	75
1461	MBh	41.8	42.6	44.6	47.6	40.8	41.6	43.6	46.5	39.9	40.6	42.5	45.4	38.9	39.6	41.5	44.3	36.9	37.6	39.4	42.1	34.2	34.9	36.5	39.0						
	S/T	0.98	0.95	0.85	0.69	1.00	0.98	0.89	0.72	1.00	1.00	0.91	0.74	1.00	1.00	0.94	0.76	1.00	1.00	0.97	0.79	1.00	1.00	0.98	0.80						
	Delta T	26	25	24	21	26	26	24	21	25	26	24	21	24	25	24	21	23	24	24	21	22	22	23	20						
	KW	2.61	2.66	2.75	2.84	2.81	2.87	2.97	3.07	2.99	3.06	3.16	3.27	3.15	3.22	3.33	3.45	3.29	3.36	3.48	3.60	3.41	3.49	3.60	3.73						
	AMPS	11.8	12.1	12.4	12.8	12.7	12.9	13.3	13.8	13.6	13.9	14.3	14.8	14.5	14.8	15.2	15.7	15.3	15.6	16.1	16.7	16.1	16.5	17.0	17.6						
	HI PR	243	262	276	288	273	294	310	324	310	334	353	368	354	380	402	419	398	428	452	471	439	473	499	521						
	LO PR	113	120	131	140	119	127	138	147	124	132	144	153	130	138	151	161	136	145	158	169	141	150	164	175						
	1300	MBh	40.6	41.4	43.3	46.2	39.6	40.4	42.3	45.1	38.7	39.4	41.3	44.1	37.7	38.5	40.3	43.0	35.9	36.6	38.3	40.8	33.2	33.9	35.5	37.8					
		S/T	0.94	0.90	0.82	0.66	0.97	0.94	0.85	0.69	1.00	0.96	0.87	0.70	1.00	0.99	0.89	0.73	1.00	1.00	0.93	0.75	1.00	1.00	0.94	0.76					
		Delta T	27	26	25	22	27	27	25	22	2																				

# COOLING PERFORMANCE DATA

# GPC1448H41AA

## EXPANDED PERFORMANCE DATA

## EXPANDED PERFORMANCE DATA

## MODEL: GPC1448H41A\*

## COOLING OPERATION

IDB*	Airflow	Outdoor Ambient Temperature																																																																																																			
		65				75				85				95				105				115																																																																															
		59	63	67	71	59	63	67	71	59	63	67	71	59	63	67	71	59	63	67	71	59	63	67	71																																																																												
70	1800	MBh	45.6	47.2	51.7	-	44.5	46.1	50.5	-	43.4	45.0	49.3	-	42.4	43.9	48.1	-	40.3	41.7	45.7	-	37.3	38.7	42.4	-	S/T	0.76	0.64	0.44	-	0.79	0.66	0.46	-	0.81	0.68	0.47	-	0.84	0.70	0.48	-	0.87	0.73	0.50	-	0.88	0.73	0.51	-	Delta T	18	15	12	-	18	16	12	-	18	16	12	-	18	16	12	-	17	15	12	-	17	14	11	-																									
	KW	2.94	3.01	3.10	-	3.17	3.24	3.34	-	3.37	3.44	3.56	-	3.55	3.63	3.75	-	3.70	3.78	3.91	-	3.83	3.91	4.04	-	AMPS	12.7	13.0	13.4	-	13.7	14.0	14.4	-	14.7	15.0	15.5	-	15.6	16.0	16.5	-	16.6	16.9	17.4	-	17.5	17.9	18.4	-	HI PR	236	254	268	-	264	284	300	-	301	324	342	-	342	369	389	-	385	415	438	-	426	458	484	-	LO PR	110	117	128	-	117	124	135	-	121	129	141	-	127	135	148	-	133	142	155	-	138	147	160	-	
	1600	MBh	44.2	45.9	50.2	-	43.2	44.8	49.1	-	42.2	43.7	47.9	-	41.2	42.7	46.7	-	39.1	40.5	44.4	-	36.2	37.5	41.1	-	S/T	0.73	0.61	0.42	-	0.75	0.63	0.44	-	0.77	0.65	0.45	-	0.80	0.67	0.46	-	0.83	0.69	0.48	-	0.84	0.70	0.48	-	Delta T	18	16	12	-	19	16	12	-	19	16	12	-	19	16	12	-	17	15	11	-	17	15	11	-																									
	KW	2.92	2.98	3.08	-	3.14	3.21	3.32	-	3.34	3.42	3.53	-	3.52	3.60	3.71	-	3.67	3.75	3.87	-	3.80	3.88	4.01	-	AMPS	12.6	12.9	13.3	-	13.6	13.8	14.3	-	14.6	14.9	15.4	-	15.5	15.9	16.3	-	16.4	16.8	17.3	-	17.3	17.7	18.2	-	HI PR	233	251	265	-	262	282	297	-	298	320	338	-	339	365	385	-	381	410	433	-	421	454	479	-	LO PR	109	116	127	-	116	123	134	-	120	128	139	-	126	134	146	-	132	141	153	-	137	145	159	-	
	1400	MBh	40.8	42.3	46.4	-	39.9	41.3	45.3	-	38.9	40.4	44.2	-	38.0	39.4	43.1	-	36.1	37.4	41.0	-	33.4	34.6	38.0	-	S/T	0.70	0.59	0.41	-	0.73	0.61	0.42	-	0.75	0.62	0.43	-	0.77	0.64	0.45	-	0.80	0.67	0.46	-	0.81	0.67	0.47	-	Delta T	19	16	12	-	19	16	13	-	19	17	13	-	19	16	12	-	18	15	12	-	18	15	12	-																									
	KW	2.85	2.91	3.00	-	3.07	3.13	3.23	-	3.26	3.33	3.44	-	3.43	3.51	3.62	-	3.57	3.65	3.78	-	3.70	3.78	3.91	-	AMPS	12.3	12.6	13.0	-	13.2	13.5	13.9	-	14.2	14.5	15.0	-	15.1	15.5	15.9	-	16.0	16.4	16.9	-	16.9	17.2	17.8	-	HI PR	226	243	257	-	254	273	289	-	289	311	328	-	329	354	374	-	370	398	420	-	409	440	465	-	LO PR	106	113	123	-	112	119	130	-	116	124	135	-	122	130	142	-	128	136	149	-	133	141	154	-	
	75	1800	MBh	46.3	47.7	51.6	55.4	45.3	46.6	50.4	54.1	44.2	45.5	49.2	52.8	43.1	44.4	48.0	51.6	41.0	42.2	45.6	49.0	37.9	39.1	42.3	45.4	S/T	0.87	0.78	0.59	0.38	0.90	0.80	0.61	0.39	0.92	0.82	0.62	0.40	0.95	0.85	0.64	0.41	0.99	0.88	0.67	0.43	1.00	0.89	0.67	0.43	Delta T	21	19	15	11	21	19	16	11	21	19	16	11	21	19	16	11	21	19	16	11	19	18	15	10																								
		KW	2.97	3.03	3.13	3.23	3.20	3.27	3.37	3.48	3.40	3.47	3.59	3.71	3.58	3.66	3.78	3.90	3.73	3.81	3.94	4.07	3.86	3.95	4.08	4.22	AMPS	12.8	13.1	13.5	14.0	13.8	14.1	14.5	15.0	14.8	15.2	15.6	16.2	15.8	16.1	16.6	17.2	16.7	17.1	17.6	18.2	17.6	18.0	18.6	19.2	HI PR	238	256	270	282	267	287	303	317	304	327	345	360	346	372	393	410	389	419	442	461	430	463	489	510	LO PR	112	119	130	138	118	125	137	146	122	130	142	152	129	137	149	159	135	143	157	167	139	148	162	173
		1600	MBh	45.0	46.3	50.1	53.8	43.9	45.2	49.0	52.6	42.9	44.2	47.8	51.3	41.9	43.1	46.6	50.1	39.8	40.9	44.3	47.6	36.8	37.9	41.0	44.0	S/T	0.83	0.74	0.56	0.36	0.86	0.77	0.58	0.37	0.88	0.79	0.59	0.38	0.91	0.81	0.61	0.40	0.94	0.84	0.64	0.41	0.95	0.85	0.64	0.41	Delta T	21	20	16	11	22	20	16	11	22	20	16	11	22	20	16	11	22	20	16	11	20	18	15	10																								
		KW	2.94	3.01	3.10	3.20	3.17	3.24	3.34	3.45	3.37	3.44	3.56	3.68	3.55	3.63	3.75	3.87	3.70	3.78	3.91	4.04	3.83	3.91	4.05	4.18	AMPS	12.7	13.0	13.4	13.8	13.7	14.0	14.4	14.9	14.7	15.0	15.5	16.0	15.6	16.0	16.5	17.0	16.6	16.9	17.4	18.1	17.5	17.9	18.4	19.1	HI PR	236	254	268	279	264	285	300	313	301	324	342	356	343	369	389	406	385	415	438	457	426	458	484	505	LO PR	110	118	128	137	117	124	136	144	121	129	141	150	127	136	148	158	134	142	155	165	138	147	160	171
1400		MBh	41.5	42.8	46.3	49.7	40.6	41.8	45.2	48.5	39.6	40.8	44.1	47.4	38.6	39.8	43.0	46.2	36.7	37.8	40.9	43.9	34.0	35.0	37.9	40.7	S/T	0.80	0.71	0.54	0.35	0.83	0.74	0.56	0.36	0.85	0.76	0.57	0.37	0.87	0.78	0.59	0.38	0.91	0.81	0.61	0.40	0.92	0.82	0.62	0.40	Delta T	22	20	16	11	22	20	17	11	22	20	17	12	22	20	17	12	22	20	17	11	20	19	15	11																									
KW		2.87	2.93	3.03	3.12	3.09	3.16	3.26	3.37	3.29	3.36	3.47	3.58	3.46	3.54	3.65	3.77	3.61	3.69	3.81	3.94	3.73	3.81	3.94	4.08	AMPS	12.4	12.7	13.1	13.5	13.3	13.6	14.0	14.5	14.4	14.7	15.1	15.6	15.2	15.6	16.1	16.6	16.1	16.5	17.0	17.6	17.0	17.4	17.9	18.6	HI PR	229	246	260	271	256	276	291	304	292	314	331	346	332	358	378	394	374	402	425	443	413	444	469	489	LO PR	107	114	124	133	113	120	131	140	118	125	137	146	124	131	144	153	129	138	150	160	134	143	156	166	

\* IDB: Entering Indoor Dry Bulb Temperature

High and low pressures are measured at the liquid and suction access fittings.

NOTE: Shaded area is ACCA (TVA) conditions

# COOLING PERFORMANCE DATA

# GPC1448H41AA

MODEL: GPC1448H41A\*

EXPANDED PERFORMANCE DATA

COOLING OPERATION

IDB*	Airflow	Outdoor Ambient Temperature																													
		65					75					85					95					105					115				
		59	63	67	71	75	59	63	67	71	75	59	63	67	71	75	59	63	67	71	75	59	63	67	71	75	59	63	67	71	75
1800	MBh	47.2	48.2	51.5	55.0	58.5	46.1	47.1	50.3	53.8	57.3	45.0	46.0	49.1	52.5	56.0	43.9	44.8	47.9	51.2	54.7	41.7	42.6	45.5	48.6	51.7	38.6	39.5	42.1	45.1	48.1
	S/T	0.95	0.89	0.73	0.54	0.37	1.00	0.92	0.75	0.56	0.39	1.00	0.95	0.77	0.58	0.41	1.00	1.00	0.80	0.60	0.41	1.00	1.00	0.83	0.62	0.42	1.00	1.00	0.83	0.62	0.42
	Delta T	23	22	19	15	12	24	22	19	15	12	23	22	19	15	12	22	23	19	16	12	21	22	19	15	12	20	20	18	14	11
	KW	2.99	3.05	3.15	3.25	3.35	3.22	3.29	3.40	3.51	3.61	3.43	3.50	3.62	3.74	3.84	3.61	3.69	3.81	3.94	4.04	3.76	3.85	3.97	4.11	4.21	3.89	3.98	4.11	4.26	4.36
	AMPS	13.0	13.2	13.6	14.1	14.6	13.9	14.2	14.6	15.1	15.6	15.0	15.3	15.8	16.3	16.8	16.3	16.8	17.3	17.8	18.3	18.3	18.8	19.3	19.8	20.3	19.8	20.3	20.8	21.3	21.8
	HI PR	240	259	273	285	297	270	290	307	320	332	307	330	349	364	379	349	376	397	414	431	393	423	447	466	484	434	467	494	515	536
	LO PR	113	120	131	139	147	119	127	138	147	155	124	132	144	153	161	130	138	151	161	170	136	145	158	168	177	141	150	164	174	183
	MBh	45.8	46.8	50.0	53.4	56.8	44.7	45.7	48.8	52.2	55.6	43.7	44.6	47.7	51.0	54.4	42.6	43.5	46.5	49.7	53.0	40.5	41.3	44.2	47.2	50.2	37.5	38.3	40.9	43.7	46.5
	S/T	0.91	0.85	0.69	0.52	0.36	0.94	0.88	0.72	0.54	0.38	0.96	0.90	0.74	0.55	0.39	0.99	0.93	0.76	0.57	0.41	1.00	0.97	0.79	0.59	0.43	1.00	0.98	0.79	0.59	0.43
	Delta T	24	23	20	16	12	24	23	20	16	12	24	23	20	16	12	24	23	20	16	12	24	23	20	16	12	22	21	19	15	11
1600	KW	2.97	3.03	3.13	3.23	3.33	3.20	3.27	3.37	3.48	3.58	3.40	3.47	3.59	3.71	3.81	3.58	3.66	3.78	3.91	4.01	3.73	3.81	3.94	4.07	4.17	3.86	3.95	4.08	4.22	4.32
	AMPS	12.9	13.1	13.5	14.0	14.5	13.8	14.1	14.5	15.0	15.5	14.8	15.2	15.6	16.2	16.7	16.1	16.6	17.2	17.8	18.3	18.3	18.8	19.3	19.8	20.3	20.8	21.3	21.8	22.3	22.8
	HI PR	238	256	270	282	294	267	287	304	317	330	304	327	345	360	374	346	372	393	410	424	389	419	442	461	475	430	463	489	510	524
	LO PR	112	119	130	138	146	118	125	137	146	154	122	130	142	152	161	129	137	149	159	168	135	143	157	167	176	139	148	162	173	182
	MBh	42.3	43.2	46.1	49.3	52.5	41.3	42.2	45.1	48.2	51.4	40.3	41.2	44.0	47.0	50.0	39.3	40.2	42.9	45.9	49.0	37.3	38.2	40.8	43.6	46.4	34.6	35.4	37.8	40.4	43.0
	S/T	0.87	0.82	0.67	0.50	0.34	0.91	0.85	0.69	0.52	0.36	0.93	0.87	0.71	0.53	0.37	0.96	0.90	0.73	0.55	0.39	1.00	0.93	0.76	0.57	0.41	1.00	0.94	0.77	0.57	0.41
	Delta T	24	23	20	16	12	25	24	20	16	12	25	24	20	16	12	25	24	21	16	12	24	23	20	16	12	23	22	19	15	11
	KW	2.90	2.96	3.05	3.15	3.25	3.12	3.19	3.29	3.40	3.50	3.31	3.39	3.50	3.61	3.71	3.49	3.57	3.68	3.81	3.91	3.64	3.72	3.84	3.97	4.07	3.76	3.85	3.98	4.11	4.21
	AMPS	12.5	12.8	13.2	13.6	14.0	13.4	13.7	14.1	14.6	15.0	14.5	14.8	15.2	15.8	16.3	16.3	16.6	17.1	17.7	18.2	18.2	18.5	19.0	19.5	20.0	20.5	21.0	21.5	22.0	22.5
	HI PR	231	248	262	274	286	259	279	294	307	320	295	317	335	349	363	336	361	381	398	414	378	406	429	447	464	417	449	474	494	514
LO PR	108	115	126	134	141	114	122	133	141	149	119	126	138	147	155	125	133	145	154	162	131	139	152	162	170	135	144	157	167	176	

NOTE: Shaded area reflects AHRI rating conditions

IDB*	Airflow	Outdoor Ambient Temperature																													
		65					75					85					95					105					115				
		59	63	67	71	75	59	63	67	71	75	59	63	67	71	75	59	63	67	71	75	59	63	67	71	75	59	63	67	71	75
1800	MBh	48.0	48.9	51.2	54.7	58.1	46.9	47.8	50.0	53.4	56.8	45.8	46.6	48.8	52.1	55.5	44.6	45.5	47.7	50.8	54.0	42.4	43.2	45.3	48.3	51.3	39.3	40.0	41.9	44.7	47.5
	S/T	1.00	0.96	0.87	0.70	0.54	1.00	1.00	0.90	0.73	0.57	1.00	1.00	0.92	0.75	0.59	1.00	1.00	0.95	0.77	0.61	1.00	1.00	0.99	0.80	0.64	1.00	1.00	1.00	0.81	0.65
	Delta T	24	24	23	20	16	24	24	23	20	16	23	23	23	20	16	23	23	23	20	16	22	22	23	20	16	20	20	21	18	14
	KW	3.01	3.08	3.18	3.28	3.38	3.25	3.32	3.43	3.54	3.64	3.46	3.53	3.65	3.77	3.87	3.64	3.72	3.84	3.97	4.07	3.79	3.88	4.01	4.14	4.24	3.93	4.02	4.15	4.29	4.43
	AMPS	13.1	13.3	13.7	14.2	14.7	14.0	14.3	14.7	15.2	15.7	15.1	15.4	15.9	16.4	16.9	16.0	16.4	16.9	17.5	18.0	17.0	17.4	17.9	18.5	19.0	17.9	18.3	18.9	19.6	20.1
	HI PR	243	261	276	288	300	272	293	310	323	336	310	333	352	367	381	353	380	401	418	432	397	427	451	471	491	439	472	499	520	540
	LO PR	114	121	132	141	149	120	128	140	149	157	125	133	145	155	164	131	140	152	162	171	138	146	160	170	180	142	151	165	176	186
	MBh	46.6	47.5	49.7	53.1	56.5	45.5	46.4	48.6	51.8	55.0	44.4	45.3	47.4	50.6	53.8	43.3	44.2	46.3	49.4	52.6	41.2	42.0	44.0	46.9	50.0	38.1	38.9	40.7	43.4	46.1
	S/T	0.95	0.92	0.83	0.67	0.51	0.99	0.95	0.86	0.70	0.54	1.00	0.97	0.88	0.71	0.55	1.00	1.00	0.91	0.74	0.58	1.00	1.00	0.94	0.76	0.60	1.00	1.00	0.95	0.77	0.61
	Delta T	25	25	24	20	16	26	25	24	21	17	26	25	24	21	17	25	25	24	21	17	24	24	24	21	17	22	22	22	19	15
1600	KW	2.99	3.05	3.15	3.25	3.35	3.22	3.29	3.40	3.51	3.61	3.43	3.50	3.62	3.74	3.84	3.61	3.69	3.81	3.94	4.04	3.76	3.85	3.97	4.11	4.21	3.89	3.98	4.11	4.26	4.36
	AMPS	13.0	13.2	13.6	14.1	14.6	13.9	14.2	14.6	15.1	15.6	15.0	15.3	15.8	16.3	16.8	16.3	16.8	17.3	17.8	18.3	18.3	18.8	19.3	19.8	20.3	20.8	21.3	21.8	22.3	22.8
	HI PR	240	259	273	285	297	270	290	307	320	332	307	330	349	364	379	349	376	397	414	431	393	423	447	466	484	434	467	494	515	536
	LO PR	113	120	131	139	147	119	127	138	147	155	124	132	144	153	161	130	138	151	161	170	136	145	158	168	177	141	150	164	174	183
	MBh	43.0	43.8	45.9	49.0	52.2	42.0	42.8	44.8	47.8	50.9	41.0	41.8	43.8	46.7	50.0	40.0	40.8	42.7	45.6	49.0	38.0	38.7	40.6	43.3	46.1	35.2	35.9	37.6	40.1	42.6
	S/T	0.92	0.88	0.80	0.65	0.49	0.95	0.92	0.83	0.67	0.51	0.97	0.94	0.85	0.69	0.53	1.00	0.97	0.88	0.71	0.55	1.00	1.00	0.91	0.74	0.58	1.00	1.00	0.92	0.74	0.58
	Delta T	26	25	24	21	17	26	26	24	21	17	26	26	24	21	17	26	26	25	21	17	25	25	24	21	17	23	24	23	20	16
	KW	2.92	2.98	3.07	3.17	3.27	3.14	3.21	3.31	3.42	3.52	3.34	3.42	3.53	3.64	3.74	3.52	3.60	3.71	3.84	3.94	3.67	3.75	3.87	4.00	4.10	3.79	3.88	4.01	4.15	4.25
	AMPS	12.6	12.9	13.3	13.7	14.1	13.5	13.8	14.2	14.7	15.1	14.6	14.9	15.4	15.9	16.4	15.5	15.8	16.3	16.9	17.4	17.3	17.8	18.3	18.8	19.3	19.8	20.3	20.8	21.3	21.8
	HI PR	233	251	265	276	288	262	282	297	310	322	298	320	338	353	365	339	365	385	402	414	381	410	433	452	471	421	453	479	499	519
LO PR	109	116	127	135	143	115																									



# COOLING PERFORMANCE DATA

# GPC1460H41AA

MODEL: GPC1460H41A\*

## EXPANDED PERFORMANCE DATA

COOLING OPERATION

IDB*	Airflow	Outdoor Ambient Temperature																				
		75				85				105				115								
		59	63	67	71	59	63	67	71	59	63	67	71	59	63	67	71					
70	1800	MBh	56.3	58.4	64.0	-	53.7	55.7	61.0	-	52.4	54.3	59.5	-	49.8	51.6	56.5	-	46.1	47.8	52.4	-
	S/T	0.71	0.60	0.41	-	0.74	0.62	0.43	-	0.76	0.63	0.44	-	0.78	0.65	0.45	-	0.81	0.68	0.47	-	
	Delta T	21	18	14	-	21	18	14	-	21	18	14	-	21	18	14	-	19	17	13	-	
	KW	3.70	3.78	3.91	-	4.00	4.09	4.23	-	4.26	4.36	4.51	-	4.49	4.60	4.75	-	4.69	4.80	4.96	-	
	AMPS	15.7	16.0	16.5	-	16.9	17.2	17.8	-	18.2	18.6	19.2	-	19.4	19.9	20.5	-	20.6	21.1	21.7	-	
	HI PR	238	256	271	-	267	288	304	-	304	327	345	-	346	373	393	-	390	419	443	-	
	LO PR	108	115	125	-	114	121	132	-	118	126	137	-	124	132	144	-	130	139	151	-	
	MBh	54.7	56.7	62.1	-	53.4	55.4	60.7	-	52.2	54.1	59.2	-	50.9	52.7	57.8	-	48.3	50.1	54.9	-	
	S/T	0.68	0.57	0.39	-	0.71	0.59	0.41	-	0.72	0.60	0.42	-	0.75	0.62	0.43	-	0.78	0.65	0.45	-	
	Delta T	21	19	14	-	22	19	14	-	22	19	14	-	22	19	14	-	20	17	13	-	
1600	KW	3.67	3.75	3.88	-	3.97	4.06	4.19	-	4.23	4.32	4.47	-	4.46	4.56	4.71	-	4.65	4.76	4.92	-	
	AMPS	15.6	15.9	16.4	-	16.7	17.1	17.6	-	18.1	18.5	19.1	-	19.2	19.7	20.3	-	20.4	20.9	21.5	-	
	HI PR	236	254	268	-	265	285	301	-	301	324	342	-	343	369	390	-	386	415	438	-	
	LO PR	107	114	124	-	113	120	131	-	117	125	136	-	123	131	143	-	129	137	150	-	
	MBh	50.5	52.3	57.3	-	49.3	51.1	56.0	-	48.1	49.9	54.7	-	47.0	48.7	53.3	-	44.6	46.2	50.7	-	
	S/T	0.66	0.55	0.38	-	0.68	0.57	0.39	-	0.70	0.58	0.40	-	0.72	0.60	0.42	-	0.75	0.62	0.43	-	
	Delta T	22	19	14	-	22	19	14	-	22	19	15	-	22	19	15	-	22	19	14	-	
	KW	3.58	3.66	3.78	-	3.87	3.95	4.08	-	4.12	4.21	4.35	-	4.34	4.44	4.59	-	4.53	4.63	4.79	-	
	AMPS	15.2	15.5	16.0	-	16.3	16.7	17.2	-	17.6	18.0	18.6	-	18.7	19.2	19.8	-	19.9	20.3	21.0	-	
	HI PR	229	246	260	-	257	276	292	-	292	314	332	-	333	358	378	-	374	403	425	-	
LO PR	103	110	120	-	109	116	127	-	114	121	132	-	119	127	139	-	125	133	145	-		
1400	MBh	57.3	59.0	63.9	68.5	56.0	57.6	62.4	66.9	54.6	56.3	60.9	65.3	53.3	54.9	59.4	63.8	50.6	52.1	56.4	60.6	
	S/T	0.81	0.73	0.55	0.35	0.84	0.75	0.57	0.37	0.86	0.77	0.58	0.38	0.89	0.80	0.60	0.39	0.92	0.83	0.63	0.40	
	Delta T	24	22	18	12	24	22	18	13	24	22	18	13	24	22	18	13	24	22	18	12	
	KW	3.73	3.82	3.94	4.07	4.03	4.12	4.26	4.41	4.30	4.40	4.55	4.70	4.53	4.64	4.79	4.96	4.73	4.84	5.01	5.18	
	AMPS	15.8	16.2	16.7	17.2	17.0	17.4	17.9	18.6	18.4	18.8	19.4	20.1	19.6	20.0	20.7	21.4	20.8	21.3	21.9	22.7	
	HI PR	241	259	273	285	270	291	307	320	307	330	349	364	350	376	397	415	393	423	447	466	
	LO PR	109	116	126	135	115	122	134	142	120	127	139	148	126	134	146	155	132	140	153	163	
	MBh	55.6	57.3	62.0	66.5	54.3	55.9	60.6	65.0	53.0	54.6	59.1	63.4	51.8	53.3	57.7	61.9	49.2	50.6	54.8	58.8	
	S/T	0.77	0.69	0.52	0.34	0.80	0.72	0.54	0.35	0.82	0.74	0.56	0.36	0.85	0.76	0.58	0.37	0.88	0.79	0.60	0.38	
	Delta T	25	23	19	13	25	23	19	13	25	23	19	13	25	23	19	13	25	23	19	13	
75	1800	KW	3.70	3.79	3.91	4.04	4.00	4.09	4.23	4.37	4.26	4.36	4.51	4.66	4.49	4.60	4.75	4.92	4.69	4.80	4.96	5.14
	AMPS	15.7	16.0	16.5	17.1	16.9	17.3	17.8	18.4	18.2	18.6	19.2	19.9	19.4	19.9	20.5	21.2	20.6	21.1	21.7	22.5	
	HI PR	238	256	271	282	267	288	304	317	304	327	346	360	346	373	394	410	390	419	443	462	
	LO PR	108	115	125	133	114	121	132	141	118	126	137	146	124	132	144	154	130	139	151	161	
	MBh	51.3	52.9	57.2	61.4	50.2	51.6	55.9	60.0	49.0	50.4	54.6	58.6	47.8	49.2	53.2	57.1	45.4	46.7	50.6	54.3	
	S/T	0.75	0.67	0.51	0.33	0.77	0.69	0.52	0.34	0.79	0.71	0.54	0.35	0.82	0.73	0.55	0.36	0.85	0.76	0.58	0.37	
	Delta T	25	23	19	13	25	23	19	13	26	24	19	13	26	24	19	13	25	23	19	13	
	KW	3.61	3.69	3.81	3.94	3.90	3.99	4.12	4.26	4.15	4.25	4.39	4.54	4.38	4.48	4.63	4.79	4.57	4.67	4.83	5.00	
	AMPS	15.3	15.6	16.1	16.7	16.4	16.8	17.3	17.9	17.8	18.2	18.7	19.4	18.9	19.3	19.9	20.7	20.0	20.5	21.2	21.9	
	HI PR	231	249	263	274	259	279	295	307	295	317	335	350	336	361	382	398	378	407	429	448	
LO PR	105	111	121	129	110	118	128	137	115	122	133	142	121	128	140	149	126	134	147	156		

\* IDB: Entering Indoor Dry Bulb Temperature

High and low pressures are measured at the liquid and suction access fittings.

NOTE: Shaded area is ACCA (TVA) conditions

# COOLING PERFORMANCE DATA

# GPC1460H41AA

IDB* Airflow	Outdoor Ambient Temperature																								
	65				75				85				95				105				115				
	59	63	67	71	59	63	67	71	59	63	67	71	59	63	67	71	59	63	67	71	59	63	67	71	
1800	MBh	58.3	59.6	63.7	68.1	57.0	58.2	62.2	66.5	55.6	56.8	60.7	64.9	54.3	55.4	59.2	63.3	51.5	52.7	56.3	60.1	47.7	48.8	52.1	55.7
	S/T	0.89	0.84	0.68	0.51	0.92	0.87	0.70	0.53	0.95	0.89	0.72	0.54	1.00	0.92	0.75	0.56	1.00	0.95	0.77	0.58	1.00	0.96	0.78	0.58
	Delta T	2.7	2.5	2.2	1.8	2.7	2.6	2.2	1.8	2.8	2.6	2.2	1.8	2.8	2.6	2.2	1.8	2.6	2.6	2.2	1.8	2.4	2.4	2.1	1.7
	KW	3.77	3.85	3.98	4.11	4.07	4.16	4.30	4.45	4.34	4.43	4.58	4.74	4.57	4.68	4.84	5.00	4.77	4.88	5.05	5.23	4.95	5.06	5.24	5.42
	AMPS	16.0	16.3	16.8	17.4	17.2	17.5	18.1	18.7	18.5	19.0	19.6	20.3	19.8	20.2	20.8	21.6	21.0	21.4	22.1	22.9	22.1	22.7	23.4	24.2
	HI PR	243	262	276	288	273	294	310	323	310	334	352	368	353	380	401	419	397	428	452	471	439	473	499	520
	LO PR	110	117	128	136	116	124	135	144	121	128	140	149	127	135	147	157	133	141	154	164	137	146	160	170
	MBh	56.6	57.9	61.8	66.1	55.3	56.5	60.4	64.5	54.0	55.2	58.9	63.0	52.7	53.8	57.5	61.5	50.0	51.1	54.6	58.4	46.3	47.4	50.6	54.1
	S/T	0.85	0.80	0.65	0.48	0.88	0.83	0.67	0.50	0.90	0.85	0.69	0.52	0.93	0.87	0.71	0.53	0.97	0.91	0.74	0.55	0.98	0.91	0.74	0.56
	Delta T	2.8	2.6	2.3	1.8	2.8	2.7	2.3	1.9	2.8	2.7	2.3	1.9	2.8	2.7	2.3	1.9	2.8	2.7	2.3	1.9	2.6	2.5	2.2	1.7
1600	KW	3.73	3.82	3.94	4.08	4.03	4.13	4.26	4.41	4.30	4.40	4.55	4.70	4.53	4.64	4.80	4.96	4.73	4.84	5.01	5.18	4.90	5.02	5.19	5.37
	AMPS	15.8	16.2	16.7	17.2	17.0	17.4	17.9	18.6	18.4	18.8	19.4	20.1	19.6	20.0	20.7	21.4	20.8	21.3	21.9	22.7	21.9	22.5	23.2	24.0
	HI PR	241	259	273	285	270	291	307	320	307	331	349	364	350	376	398	415	394	423	447	466	435	468	494	515
	LO PR	109	116	126	135	115	122	134	142	120	127	139	148	126	134	146	155	132	140	153	163	136	145	158	168
	MBh	52.3	53.4	57.1	61.0	51.0	52.2	55.7	59.6	49.8	50.9	54.4	58.2	48.6	49.7	53.1	56.7	46.2	47.2	50.4	53.9	42.8	43.7	46.7	49.9
	S/T	0.82	0.77	0.63	0.47	0.85	0.80	0.65	0.48	0.87	0.82	0.66	0.50	0.90	0.84	0.69	0.51	0.93	0.87	0.71	0.53	0.94	0.88	0.72	0.54
	Delta T	2.8	2.7	2.3	1.9	2.8	2.7	2.4	1.9	2.8	2.7	2.4	1.9	2.9	2.7	2.4	1.9	2.8	2.7	2.4	1.9	2.6	2.5	2.2	1.8
	KW	3.64	3.72	3.84	3.97	3.93	4.02	4.15	4.29	4.19	4.28	4.43	4.58	4.42	4.52	4.67	4.83	4.61	4.71	4.88	5.05	4.78	4.89	5.05	5.23
	AMPS	15.4	15.8	16.2	16.8	16.6	17.0	17.5	18.1	17.9	18.3	18.9	19.6	19.1	19.5	20.1	20.8	20.2	20.7	21.3	22.1	21.4	21.9	22.6	23.4
	HI PR	233	251	265	277	262	282	298	310	298	321	339	353	339	365	386	402	382	411	434	452	422	454	479	500
LO PR	106	112	123	131	112	119	130	138	116	123	135	143	122	130	141	151	128	136	148	158	132	140	153	163	

NOTE: Shaded areas reflects AHRI rating conditions

IDB* Airflow	Outdoor Ambient Temperature																								
	65				75				85				95				105				115				
	59	63	67	71	59	63	67	71	59	63	67	71	59	63	67	71	59	63	67	71	59	63	67	71	
1800	MBh	59.3	60.5	63.3	67.6	58.0	59.1	61.9	66.0	56.6	57.7	60.4	64.4	55.2	56.3	58.9	62.9	52.4	53.5	56.0	59.7	48.6	49.5	51.9	55.3
	S/T	0.93	0.90	0.81	0.66	0.97	0.93	0.84	0.68	0.99	0.96	0.86	0.70	1.00	0.99	0.89	0.72	1.00	1.00	0.93	0.75	1.00	1.00	0.93	0.76
	Delta T	2.8	2.8	2.6	2.3	2.9	2.8	2.7	2.3	2.9	2.8	2.7	2.3	2.8	2.8	2.7	2.3	2.7	2.7	2.6	2.3	2.5	2.5	2.5	2.1
	KW	3.80	3.88	4.01	4.14	4.10	4.20	4.34	4.48	4.37	4.47	4.62	4.78	4.61	4.72	4.88	5.05	4.81	4.93	5.09	5.27	4.99	5.10	5.28	5.47
	AMPS	16.1	16.5	17.0	17.5	17.3	17.7	18.2	18.9	18.7	19.1	19.7	20.4	19.9	20.4	21.0	21.8	21.1	21.6	22.3	23.1	22.3	22.9	23.6	24.5
	HI PR	245	264	279	291	275	296	313	326	313	337	356	371	357	384	405	423	401	432	456	476	444	477	504	526
	LO PR	111	118	129	137	117	125	136	145	122	130	142	151	128	136	149	158	134	143	156	166	139	148	161	172
	MBh	57.6	58.7	61.5	65.6	56.3	57.4	60.1	64.1	54.9	56.0	58.6	62.6	53.6	54.6	57.2	61.0	50.9	51.9	54.4	58.0	47.2	48.1	50.3	53.7
	S/T	0.89	0.86	0.78	0.63	0.92	0.89	0.80	0.65	0.95	0.91	0.82	0.67	0.98	0.94	0.85	0.69	1.00	0.98	0.88	0.72	1.00	0.99	0.89	0.72
	Delta T	2.9	2.9	2.7	2.4	3.0	2.9	2.8	2.4	3.0	2.9	2.8	2.4	3.0	3.0	2.8	2.4	2.9	2.9	2.8	2.4	2.7	2.7	2.6	2.2
1600	KW	3.77	3.85	3.98	4.11	4.07	4.16	4.30	4.45	4.34	4.43	4.58	4.74	4.57	4.68	4.84	5.00	4.77	4.88	5.05	5.23	4.95	5.06	5.24	5.42
	AMPS	16.0	16.3	16.8	17.4	17.2	17.5	18.1	18.7	18.5	19.0	19.6	20.3	19.8	20.2	20.8	21.6	21.0	21.4	22.1	22.9	22.1	22.7	23.4	24.2
	HI PR	243	262	276	288	273	294	310	323	310	334	352	368	353	380	401	419	397	428	452	471	439	473	499	520
	LO PR	110	117	128	136	116	124	135	144	121	128	140	149	127	135	147	157	133	141	154	164	137	146	160	170
	MBh	53.2	54.2	56.8	60.6	51.9	52.9	55.4	59.2	50.7	51.7	54.1	57.7	49.5	50.4	52.8	56.3	47.0	47.9	50.2	53.5	43.5	44.4	46.5	49.6
	S/T	0.86	0.83	0.75	0.61	0.89	0.86	0.78	0.63	0.91	0.88	0.79	0.64	0.94	0.91	0.82	0.67	0.98	0.94	0.85	0.69	0.99	0.95	0.86	0.70
	Delta T	3.0	3.0	2.8	2.4	3.0	3.0	2.8	2.4	3.0	3.0	2.8	2.4	3.1	3.0	2.8	2.5	3.0	3.0	2.8	2.4	2.8	2.8	2.6	2.3
	KW	3.67	3.75	3.88	4.01	3.97	4.05	4.19	4.33	4.23	4.32	4.47	4.62	4.45	4.56	4.71	4.87	4.65	4.76	4.92	5.09	4.82	4.93	5.10	5.28
	AMPS	15.6	15.9	16.4	17.0	16.7	17.1	17.6	18.2	18.1	18.5	19.1	19.7	19.2	19.7	20.3	21.0	20.4	20.9	21.5	22.3	21.5	22.1	22.8	23.6
	HI PR	236	254	268	279	265	285	301	314	301	324	342	357	343	369	389	406	386	415	438	457	426	458	484	505
LO PR	107	113	124	132	113	120	131	139	117	125	136	145	123	131	143	152	129	137	150	159	133	142	155	165	

\* NOTE: Shaded areas is AHRI Rating Conditions IDB: Entering Indoor Dry Bulb Temperature KW = Total system power  
 High and low pressures are measured at the liquid and suction access fittings. AMPS: Unit amps (comp.+ evaporator + condenser fan motors)

# COOLING PERFORMANCE DATA

## PERFORMANCE TEST

All data based upon listed indoor dry bulb temperature. .00 inches external static pressure on coil of outdoor section. Indoor air cubic feet per minute (CFM) as listed in the Performance Data Sheets:

If conditions vary from this, results will change as follows:

1. As indoor dry bulb temperatures increase, a slight increase will occur in indoor air temperature drop (Delta T). Low and high side pressures and power will not change.
2. As indoor CFM decreases, a slight increase will occur in indoor temperature drop (Delta T). A slight decrease will occur in low and high side pressures and power.

A properly operating unit should be within plus or minus **3 degrees** of the typical (**Delta T**) value shown.

A properly operating unit should be within plus or minus **7 PSIG** of the **HI PR** shown.

A properly operating unit should be within plus or minus **3 PSIG** of the **LO PR** shown.

A properly operating unit should be within plus or minus **3 Amps** of the typical value shown.



# GPC 14 SEER R-410A 5mm Package Air Conditioners

GPC1424H41AB	GPC1424H41B*	GPC1424H41C*	GPC1424H41D*
GPC1430H41AB	GPC1430H41B*	GPC1430H41C*	APC1424H41D*
GPC1436H41AB	GPC1436H41B*	GPC1436H41C*	*PC1430H41D*
GPC1442H41AB	GPC1442H41B*	GPC1442H41C*	*PC1436H41D*
GPC1448H41AB	GPC1448H41B*	GPC1448H41C*	*PC1442H41D*
	GPC1460H41B*	GPC1460H41C*	*PC1448H41D*
			*PC1460H41D*

## PRODUCT DESIGN

\*PC14 Package Cooling Units are designed for outdoor installations only in either residential or light commercial applications.

The connecting ductwork (Supply and Return) can be connected for either horizontal or vertical airflow. In the vertical application a matching Roof Curb is recommended.

A return air filter must be installed behind the return air grille(s) or provision must be made for a filter in an accessible location within the return air duct. The minimum filter area should not be less than those sizes listed in the Specification Section. Under no circumstances should the unit be operated without return air filters.

A 3/4" PVC pipe is provided for removal of condensate water from the indoor coil. In order to provide proper condensate flow, a drain trap is supplied and shipped loose inside the unit for field installation. (Do not reduce the drain line size.)

Refrigerant flow control is achieved by use of restrictor orifices. \*PC14 units use the FasTest Access Fitting System with a saddle that is either soldered to the suction and liquid lines or is fastened with a locking nut to the access fitting box (core) and then screwed into the saddle. **Do not remove the core from the saddle until the refrigerant charge has been removed. Failure to do so could result in property damage or personal injury.**

The single phase units use permanent split capacitor (PSC) design compressors. Starting components are therefore not required for these units. A low microfarad run capacitor assists the compressor to start and remains in the circuit during operation.

All \*PC14 units have EEM indoor blower motors that are energized by a 24V signal from the thermostat and are constant torque motors with very low power consumption. The EEM features an integral control module.

Air for condensing (cooling cycle) is drawn through the outdoor coil by a propeller fan, and is discharged vertically out the top of the unit. The outdoor coil is designed for .0 static. No additional restriction (ductwork) shall be applied.

Conditioned air is drawn through the filter(s), field installed, across the coil and back into the conditioned space by the indoor blower.

GPC1424-60H41AB models use Copeland Scroll Compressors. There are a number of design characteristics which are different from the traditional reciprocating compressor.

- Due to their design Scroll Compressors are inherently more tolerant of liquid refrigerant. **NOTE:** Even though the compressor section of a Scroll compressor is more tolerant of liquid refrigerant, continued floodback or flooded start conditions may wash oil from the bearing surfaces causing premature bearing failure.
- Scroll Compressors use white oil which is compatible with 3GS oil which may be used if additional oil is required.
- Operating pressures and amp draws may differ from standard reciprocating compressors. This information may be found in the "Cooling Performance Data" section.

# PRODUCT DESIGN

## Location and Clearances

**NOTE:** To ensure proper condensate drainage, unit must be installed in a level position.

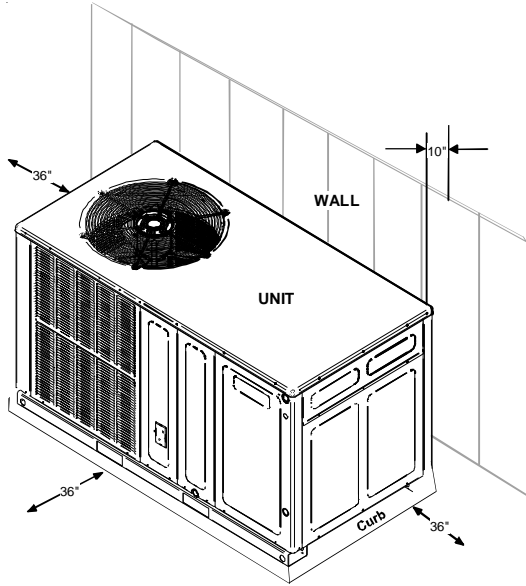

In installations where the unit is installed above ground level and not serviceable from the ground (Example: Roof Top installations), the installer must provide service platform for service person with rails or guards in accordance with local codes or ordinances or in their absence with the latest edition of the Uniform Mechanical Code Section 305.

**NOTE:** Unit can also use roof curb.

## **WARNING**

**TO PREVENT POSSIBLE PROPERTY DAMAGE, THE UNIT SHOULD REMAIN IN AN UPRIGHT POSITION DURING ALL RIGGING AND MOVING OPERATIONS. TO FACILITATE LIFTING AND MOVING IF A CRANE IS USED, PLACE THE UNIT IN AN ADEQUATE CABLE SLING.**

Refer to Roof Curb Installation Instructions for proper curb installation. Curbing must be installed in compliance with the National Roofing Contractors Association Manual.

## Outside Slab Installation - Horizontal (H)

Minimum clearances are required to avoid air recirculation and keep the unit operating at peak efficiency.

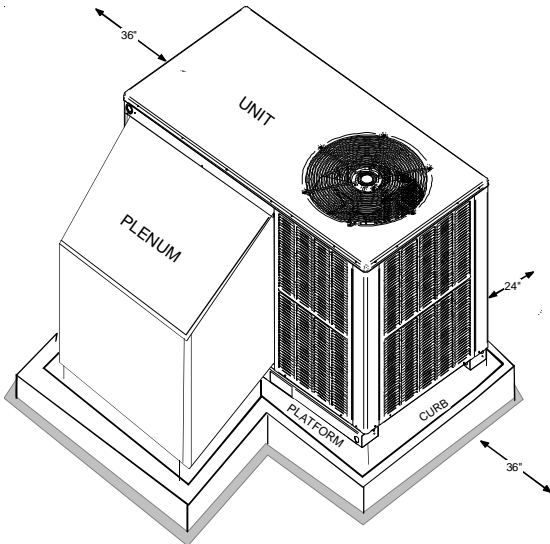

## Rooftop Installation - Horizontal (H)

# PACKAGE COOLING SPECIFICATIONS GPC14[24-36]H41AB

		GPC1424H41AB	GPC1430H41AB	GPC1436H41AB
<b>COOLING CAPACITY</b>	COOLING CAPACITY, BTUH	24,600	28,400	35,600
	SEER / EER	14.5 / 12.1	14.0 / 12.1	14.0 / 12.0
<b>UNIT ELECTRICAL SPECIFICATION</b>	VOLTAGE (NAMEPLATE)	208-230/1/60	208-230/1/60	208-230/1/60
	AMPS (TOTAL)	16.1	15.76	20.06
	MINIMUM CIRCUIT AMPACITY	19.5	19	24.2
	MAXIMUM OVERCURRENT PROTECTION <sup>(1)</sup>	30	30	40
<b>COMPRESSOR</b>	TYPE	SCROLL	SCROLL	SCROLL
	RATED LOAD AMPS	13.5	12.8	16.7
	LOCKED ROTOR AMPS	58.3	64	79
<b>CONDENSER FAN MOTOR</b>	HORSEPOWER	1/6	1/6	1/4
	RPM	815	815	830
	FULL LOAD AMPS	1.1	1.1	1.5
	LOCKED ROTOR AMPS	1.7	1.7	3.0
<b>CONDENSER FAN</b>	BLADE DIAMETER (INCHES) / # OF BLADES	22 / 2	22 / 2	22 / 3
<b>CONDENSER COIL</b>	FACE AREA - SQ. FT.	12.3	12.3	12.3
	NUMBER OF ROWS	1	1	1
	FINS PER INCH	26	26	26
<b>EVAPORATOR BLOWER MOTOR</b>	HORSEPOWER - NO. OF SPEEDS	1/2 - 5	1/2 - 5	1/2 - 5
	FULL LOAD AMPS	1.5	1.86	1.86
	LOCKED ROTOR AMPS	NA	NA	NA
	MOTOR SPEED TAP - COOLING	T2	T2	T2
	RPM	1050	1050	1050
<b>EVAPORATOR BLOWER</b>	DIAMETER X WIDTH (INCHES)	10 X 8	10 X 8	10 X 8
	HI EFFICIENCY COOLING CFM	850	1,050	1,200
	FAN ONLY COOLING CFM	800	950	1,100
	MAX EXTERNAL STATIC PRESS ("w.c.)	0.5	0.5	0.5
<b>EVAPORATOR COIL</b>	FACE AREA - SQ. FT.	5.25	5.25	5.2
	NUMBER OF ROWS	3	3	3
	FINS PER INCH	16	16	14
<b>GENERAL INFORMATION</b>	FILTER SIZE - SQ. FT. *	20 x 20 x 1	20 x 25 x 1	25 x 25 x 1
	DRAIN SIZE (INCHES)	3/4"	3/4"	3/4"
	EXPANSION DEVICE	ORIFICE (0.057)	ORIFICE (0.062)	ORIFICE (0.068)
	REFRIGERANT CHARGE R-410A (Oz.)	59	53	65
	POWER SUPPLY CONDUIT KNOCKOUT SIZE (IN.)	3/4, 1, 1-1/4	3/4, 1, 1-1/4	3/4, 1, 1-1/4
	LOW VOLTAGE CONDUIT KNOCKOUT SIZE (IN.)	1/2	1/2	1/2
	SHIPPING WEIGHT LBS.	290	290	370
	OPERATING WEIGHT LBS.	280	280	360

<sup>(1)</sup> Maximum Overcurrent Protection Device: **MUST** use Time Delay Fuse or HACR type Circuit Breaker of the same size as noted.

\* Calculated external filter size based on air velocity of 300 ft/min.

Wire size should be determined in accordance with National Electrical Codes. Extensive wire runs will require larger wire sizes.

Unit specifications are subject to change without notice. **ALWAYS** refer to the units serial plate for the most up-to-date general and electrical information.

**IMPORTANT:** While this data is presented as a guide, it is important to electrically connect the unit and properly size wires and fuses/circuit breakers in accordance with the National Electrical Code and/or all local codes. Data shown is w/o electric heaters.

# PACKAGE COOLING SPECIFICATIONS

# GPC14[42-48]H41AB

	GPC1442H41AB	GPC1448H41AB
COOLING CAPACITY, BTUH	40,000	46,500
SEER / EER	14.2 / 12.0	14.5 / 12.0
VOLTAGE (NAMEPLATE)	208-230/1/60	208-230/1/60
AMPS (TOTAL)	22.2	24.2
MINIMUM CIRCUIT AMPACITY	26.6	29.1
MAXIMUM OVERCURRENT PROTECTION <sup>(1)</sup>	40	45
TYPE	SCROLL	SCROLL
RATED LOAD AMPS	17.9	19.9
LOCKED ROTOR AMPS	112	109
HORSEPOWER	1/4	1/4
RPM	1075	1075
FULL LOAD AMPS	1.4	1.4
LOCKED ROTOR AMPS	2.9	2.9
BLADE DIAMETER (INCHES) / # OF BLADES	22 / 4	22 / 4
FACE AREA - SQ. FT.	16.0	19.5
NUMBER OF ROWS	1	1
FINS PER INCH	28	28
HORSEPOWER - NO. OF SPEEDS	1/2 - 5	3/4 - 5
FULL LOAD AMPS	2.9	2.9
LOCKED ROTOR AMPS	NA	NA
MOTOR SPEED TAP - COOLING	T2	T2
RPM	1050	1050
DIAMETER X WIDTH (INCHES)	10 x 8	10 x 8
HI EFFICIENCY COOLING CFM	1,300	1,600
5 TON NOMINAL COOLING CFM	NA	NA
FAN ONLY COOLING CFM	1,200	1,400
MAX EXTERNAL STATIC PRESS ("w.c.)	0.5	0.5
FACE AREA - SQ. FT.	6.2	6.2
NUMBER OF ROWS	4	4
FINS PER INCH	14	14
FILTER SIZE - SQ. FT. *	(2) 20 x 20 x 1	(2) 20 x 20 x 1
DRAIN SIZE (INCHES)	3/4"	3/4"
EXPANSION DEVICE	ORIFICE (0.072)	ORIFICE (0.078)
REFRIGERANT CHARGE R-410A (Oz.)	94	90
POWER SUPPLY CONDUIT KNOCKOUT SIZE (IN.)	3/4, 1, 1-1/4	3/4, 1, 1-1/4
LOW VOLTAGE CONDUIT KNOCKOUT SIZE (IN.)	1/2	1/2
SHIPPING WEIGHT LBS.	370	400
OPERATING WEIGHT LBS.	360	390

<sup>(1)</sup> Maximum Overcurrent Protection Device: **MUST** use Time Delay Fuse or HACR type Circuit Breaker of the same size as noted.

\* Calculated external filter size based on air velocity of 300 ft/min.

Wire size should be determined in accordance with National Electrical Codes. Extensive wire runs will require larger wire sizes.

Unit specifications are subject to change without notice. **ALWAYS** refer to the units serial plate for the most up-to-date general and electrical information.

**IMPORTANT:** While this data is presented as a guide, it is important to electrically connect the unit and properly size wires and fuses/circuit breakers in accordance with the National Electrical Code and/or all local codes. Data shown is w/o electric heaters.



# PACKAGE COOLING SPECIFICATIONS **GPC14[24-36]H41B\*/C\***

		<b>GPC1424H41 B*</b>	<b>GPC1424H41 C*</b>	<b>GPC1430H41 B*/C*</b>	<b>GPC1436H41 B*/C*</b>
<b>COOLING CAPACITY</b>	COOLING CAPACITY, BTUH	24,600	24,600	28,400	35,600
	SEER / EER	14.5 / 12.1	14.5 / 12.1	14.0 / 12.1	14.0 / 12.0
<b>UNIT ELECTRICAL SPECIFICATION</b>	VOLTAGE (NAMEPLATE)	208-230/1/60	208-230/1/60	208-230/1/60	208-230/1/60
	AMPS (TOTAL)	16.1	10.3	15.76	20.06
	MINIMUM CIRCUIT AMPACITY	19.5	12.2	19	24.2
	MAXIMUM OVERCURRENT PROTECTION <sup>(1)</sup>	30	15	30	40
<b>COMPRESSOR</b>	TYPE	SCROLL	ROTARY	SCROLL	SCROLL
	RATED LOAD AMPS	13.5	7.7	12.8	16.7
	LOCKED ROTOR AMPS	58.3	37	64	79
<b>CONDENSER FAN MOTOR</b>	HORSEPOWER	1/6	1/6	1/6	1/4
	RPM	815	815	815	830
	FULL LOAD AMPS	1.1	1.1	1.1	1.5
	LOCKED ROTOR AMPS	1.7	1.7	1.7	3.0
<b>CONDENSER FAN</b>	BLADE DIAMETER (INCHES) / # OF BLADES	22 / 2	22 / 2	22 / 2	22 / 3
<b>CONDENSER COIL</b>	FACE AREA - SQ. FT.	12.3	12.3	12.3	12.3
	NUMBER OF ROWS	1	1	1	1
	FINS PER INCH	26	26	26	26
<b>EVAPORATOR BLOWER MOTOR</b>	HORSEPOWER - NO. OF SPEEDS	1/2 - 5	1/2 - 5	1/2 - 5	1/2 - 5
	FULL LOAD AMPS	1.5	1.5	1.86	1.86
	LOCKED ROTOR AMPS	NA	NA	NA	NA
	MOTOR SPEED TAP - COOLING	T2	T2	T2	T2
	RPM	1050	1050	1050	1050
<b>EVAPORATOR BLOWER</b>	DIAMETER X WIDTH (INCHES)	10 X 8	10 X 8	10 X 8	10 X 8
	HI EFFICIENCY COOLING CFM	850	850	1,050	1,200
	FAN ONLY COOLING CFM	800	800	950	1,100
	MAX EXTERNAL STATIC PRESS ("w.c.)	0.5	0.5	0.5	0.5
<b>EVAPORATOR COIL</b>	FACE AREA - SQ. FT.	4.66	4.66	5.25	5.25
	NUMBER OF ROWS	3	3	3	3
	FINS PER INCH	16	16	16	14
<b>GENERAL INFORMATION</b>	FILTER SIZE - SQ. FT. *	20 x 20 x 1	20 x 20 x 1	20 x 25 x 1	25 x 25 x 1
	DRAIN SIZE (INCHES)	3/4"	3/4"	3/4"	3/4"
	EXPANSION DEVICE	ORIFICE (0.057)	ORIFICE (0.057)	ORIFICE (0.062)	ORIFICE (0.068)
	REFRIGERANT CHARGE R-410A (Oz.)	59	60	61	65
	POWER SUPPLY CONDUIT KNOCKOUT SIZE (IN.)	3/4, 1, 1-1/4	3/4, 1, 1-1/4	3/4, 1, 1-1/4	3/4, 1, 1-1/4
	LOW VOLTAGE CONDUIT KNOCKOUT SIZE (IN.)	1/2	1/2	1/2	1/2
	SHIPPING WEIGHT LBS.	310	310	315	330
	OPERATING WEIGHT LBS.	305	305	310	315

<sup>(1)</sup> Maximum Overcurrent Protection Device: **MUST** use Time Delay Fuse or HACR type Circuit Breaker of the same size as noted.

\* Calculated external filter size based on air velocity of 300 ft/min.

Wire size should be determined in accordance with National Electrical Codes. Extensive wire runs will require larger wire sizes.

Unit specifications are subject to change without notice. **ALWAYS** refer to the units serial plate for the most up-to-date general and electrical information.

**IMPORTANT:** While this data is presented as a guide, it is important to electrically connect the unit and properly size wires and fuses/circuit breakers in accordance with the National Electrical Code and/or all local codes. Data shown is w/o electric heaters.

# PACKAGE COOLING SPECIFICATIONS GPC14[42-60]H41B\*/C\*

		GPC1442H41 B*/C*	GPC1448H41 B*/C*	GPC1460H41 B*/C*
<b>COOLING CAPACITY</b>	COOLING CAPACITY, BTUH	40,000	46,500	57,500
	SEER / EER	14.0 / 12.0	14.0 / 12.0	14.0 / 12.0
<b>UNIT ELECTRICAL SPECIFICATION</b>	VOLTAGE (NAMEPLATE)	208-230/1/60	208-230/1/60	208-230/1/60
	AMPS (TOTAL)	22.2	24.2	30.7
	MINIMUM CIRCUIT AMPACITY	26.6	29.1	37.3
	MAXIMUM OVERCURRENT PROTECTION <sup>(1)</sup>	40	45	60
<b>COMPRESSOR</b>	TYPE	SCROLL	SCROLL	SCROLL
	RATED LOAD AMPS	17.9	19.9	26.4
	LOCKED ROTOR AMPS	112	109	134
<b>CONDENSER FAN MOTOR</b>	HORSEPOWER	1/4	1/4	1/4
	RPM	1075	1075	1075
	FULL LOAD AMPS	1.4	1.4	1.4
	LOCKED ROTOR AMPS	2.9	2.9	2.9
<b>CONDENSER FAN</b>	BLADE DIAMETER (INCHES) / # OF BLADES	22 / 4	22 / 4	22 / 4
<b>CONDENSER COIL</b>	FACE AREA - SQ. FT.	16.0	19.5	17
	NUMBER OF ROWS	1	1	2
	FINS PER INCH	28	28	28
<b>EVAPORATOR BLOWER MOTOR</b>	HORSEPOWER - NO. OF SPEEDS	1/2 - 5	3/4 - 5	3/4 - 5
	FULL LOAD AMPS	2.9	2.9	2.9
	LOCKED ROTOR AMPS	NA	NA	NA
	MOTOR SPEED TAP - COOLING	T2	T2	T2
	RPM	1050	1050	1050
<b>EVAPORATOR BLOWER</b>	DIAMETER X WIDTH (INCHES)	10 x 8	10 x 8	11 x 8
	HI EFFICIENCY COOLING CFM	1,300	1,600	1,700
	5 TON NOMINAL COOLING CFM	NA	NA	1,800
	FAN ONLY COOLING CFM	1,200	1,400	1,700
	MAX EXTERNAL STATIC PRESS ("w.c.)	0.5	0.5	0.5
<b>EVAPORATOR COIL</b>	FACE AREA - SQ. FT.	6.2	6.2	7.0
	NUMBER OF ROWS	4	4	4
	FINS PER INCH	14	14	14
<b>GENERAL INFORMATION</b>	FILTER SIZE - SQ. FT. *	(2) 20 x 20 x 1	(2) 20 x 20 x 1	(2) 20 x 25 x 1
	DRAIN SIZE (INCHES)	3/4"	3/4"	3/4"
	EXPANSION DEVICE	ORIFICE (0.072)	ORIFICE (0.076)	ORIFICE (0.086)
	REFRIGERANT CHARGE R-410A (Oz.)	94	90	110
	POWER SUPPLY CONDUIT KNOCKOUT SIZE (IN.)	3/4, 1, 1-1/4	3/4, 1, 1-1/4	3/4, 1, 1-1/4
	LOW VOLTAGE CONDUIT KNOCKOUT SIZE (IN.)	1/2	1/2	1/2
	SHIPPING WEIGHT LBS.	360	375	380
	OPERATING WEIGHT LBS.	355	370	375

<sup>(1)</sup> Maximum Overcurrent Protection Device: **MUST** use Time Delay Fuse or HACR type Circuit Breaker of the same size as noted.

\* Calculated external filter size based on air velocity of 300 ft/min.

Wire size should be determined in accordance with National Electrical Codes. Extensive wire runs will require larger wire sizes.

Unit specifications are subject to change without notice. **ALWAYS** refer to the units serial plate for the most up-to-date general and electrical information.

**IMPORTANT:** While this data is presented as a guide, it is important to electrically connect the unit and properly size wires and fuses/circuit breakers in accordance with the National Electrical Code and/or all local codes. Data shown is w/o electric heaters.

# PACKAGE COOLING SPECIFICATIONS

## \*PC14[24-36]H41D\*

		GPC1424H41D*	APC1424H41D*	*PC1430H41D*	*PC1436H41D*
<b>COOLING CAPACITY</b>	COOLING CAPACITY, BTUH	24,600	24,600	28,400	35,600
	SEER / EER	14.5 / 12.1	14.5 / 12.1	14.0 / 12.1	14.0 / 12.0
<b>UNIT ELECTRICAL SPECIFICATION</b>	VOLTAGE (NAMEPLATE)	208-230/1/60	208-230/1/60	208-230/1/60	208-230/1/60
	AMPS (TOTAL)	12.6	18.4	17.7	22
	MINIMUM CIRCUIT AMPACITY	15	22	21	26
	MAXIMUM OVERCURRENT PROTECTION <sup>(1)</sup>	20	35	30	40
<b>COMPRESSOR</b>	TYPE	ROTARY	SCROLL	SCROLL	SCROLL
	RATED LOAD AMPS	7.7	13.5	12.8	16.7
	LOCKED ROTOR AMPS	37	58.3	64	79
<b>CONDENSER FAN MOTOR</b>	HORSEPOWER	1/6	1/6	1/6	1/4
	RPM	815	815	815	830
	FULL LOAD AMPS	1.1	1.1	1.1	1.5
	LOCKED ROTOR AMPS	1.7	1.7	1.7	3.0
<b>CONDENSER FAN</b>	BLADE DIAMETER (INCHES) / # OF BLADES	22 / 2	22 / 2	22 / 2	22 / 3
<b>CONDENSER COIL</b>	FACE AREA - SQ. FT.	12.3	12.3	12.3	12.3
	NUMBER OF ROWS	1	1	1	1
	FINS PER INCH	26	26	26	26
<b>EVAPORATOR BLOWER MOTOR</b>	HORSEPOWER - NO. OF SPEEDS	1/2 - 5	1/2 - 5	1/2 - 5	1/2 - 5
	FULL LOAD AMPS	3.8	3.8	3.8	3.8
	LOCKED ROTOR AMPS	NA	NA	NA	NA
	MOTOR SPEED TAP - COOLING	T2	T2	T2	T2
	RPM	1050	1050	1050	1050
<b>EVAPORATOR BLOWER</b>	DIAMETER X WIDTH (INCHES)	10 X 8	10 X 8	10 X 8	10 X 8
	HI EFFICIENCY COOLING CFM	850	850	1,050	1,200
	FAN ONLY COOLING CFM	800	800	950	1,100
	MAX EXTERNAL STATIC PRESS ("w.c.)	0.8	0.8	0.8	0.8
<b>EVAPORATOR COIL</b>	FACE AREA - SQ. FT.	4.66	4.66	5.25	5.25
	NUMBER OF ROWS	3	3	3	3
	FINS PER INCH	16	16	16	14
<b>GENERAL INFORMATION</b>	FILTER SIZE - SQ. FT. *	20 x 20 x 1	20 x 20 x 1	20 x 25 x 1	25 x 25 x 1
	DRAIN SIZE (INCHES)	3/4"	3/4"	3/4"	3/4"
	EXPANSION DEVICE	ORIFICE (0.057)	ORIFICE (0.057)	ORIFICE (0.062)	ORIFICE (0.068)
	REFRIGERANT CHARGE R-410A (Oz.)	60	60	61	65
	POWER SUPPLY CONDUIT KNOCKOUT SIZE (IN.)	3/4, 1, 1-1/4	3/4, 1, 1-1/4	3/4, 1, 1-1/4	3/4, 1, 1-1/4
	LOW VOLTAGE CONDUIT KNOCKOUT SIZE (IN.)	1/2	1/2	1/2	1/2
	SHIPPING WEIGHT LBS.	310	310	315	330
	OPERATING WEIGHT LBS.	305	305	310	315

<sup>(1)</sup> Maximum Overcurrent Protection Device: **MUST** use Time Delay Fuse or HACR type Circuit Breaker of the same size as noted.

\* Calculated external filter size based on air velocity of 300 ft/min.

Wire size should be determined in accordance with National Electrical Codes. Extensive wire runs will require larger wire sizes.

Unit specifications are subject to change without notice. **ALWAYS** refer to the units serial plate for the most up-to-date general and electrical information.

**IMPORTANT:** While this data is presented as a guide, it is important to electrically connect the unit and properly size wires and fuses/circuit breakers in accordance with the National Electrical Code and/or all local codes. Data shown is w/o electric heaters.

# PACKAGE COOLING SPECIFICATIONS

**\*PC14[42-60]H41D\***

		*PC1442H41D*	*PC1448H41D*	*PC1460H41D*
<b>COOLING CAPACITY</b>	COOLING CAPACITY, BTUH	40,000	46,500	57,500
	SEER / EER	14.0 / 12.0	14.0 / 12.0	14.0 / 12.0
<b>UNIT ELECTRICAL SPECIFICATION</b>	VOLTAGE (NAMEPLATE)	208-230/1/60	208-230/1/60	208-230/1/60
	AMPS (TOTAL)	23.1	26.7	33.2
	MINIMUM CIRCUIT AMPACITY	28	32	40.0
	MAXIMUM OVERCURRENT PROTECTION <sup>(1)</sup>	45	50	60
<b>COMPRESSOR</b>	TYPE	SCROLL	SCROLL	SCROLL
	RATED LOAD AMPS	17.9	19.9	26.4
	LOCKED ROTOR AMPS	112	109	134
<b>CONDENSER FAN MOTOR</b>	HORSEPOWER	1/4	1/4	1/4
	RPM	1075	1075	1075
	FULL LOAD AMPS	1.4	1.4	1.4
	LOCKED ROTOR AMPS	2.9	2.9	2.9
<b>CONDENSER FAN</b>	BLADE DIAMETER (INCHES) / # OF BLADES	22 / 4	22 / 4	22 / 4
<b>CONDENSER COIL</b>	FACE AREA - SQ. FT.	16.0	19.5	17
	NUMBER OF ROWS	1	1	2
	FINS PER INCH	28	28	28
<b>EVAPORATOR BLOWER MOTOR</b>	HORSEPOWER - NO. OF SPEEDS	1/2 - 5	3/4 - 5	3/4 - 5
	FULL LOAD AMPS	3.8	5.4	5.4
	LOCKED ROTOR AMPS	NA	NA	NA
	MOTOR SPEED TAP - COOLING	T2	T2	T2
	RPM	1050	1050	1050
<b>EVAPORATOR BLOWER</b>	DIAMETER X WIDTH (INCHES)	10 x 8	10 x 8	11 x 8
	HI EFFICIENCY COOLING CFM	1,300	1,600	1,700
	5 TON NOMINAL COOLING CFM	NA	NA	1,800
	FAN ONLY COOLING CFM	1,200	1,400	1,700
	MAX EXTERNAL STATIC PRESS ("w.c.)	0.5 / 0.8**	0.5 / 0.8**	0.5 / 0.8**
<b>EVAPORATOR COIL</b>	FACE AREA - SQ. FT.	6.2	6.2	7.0
	NUMBER OF ROWS	4	4	4
	FINS PER INCH	14	14	14
<b>GENERAL INFORMATION</b>	FILTER SIZE - SQ. FT. *	(2) 20 x 20 x 1	(2) 20 x 20 x 1	(2) 20 x 25 x 1
	DRAIN SIZE (INCHES)	3/4"	3/4"	3/4"
	EXPANSION DEVICE	ORIFICE (0.072)	ORIFICE (0.076)	ORIFICE (0.086)
	REFRIGERANT CHARGE R-410A (Oz.)	94	90	110
	POWER SUPPLY CONDUIT KNOCKOUT SIZE (IN.)	3/4, 1, 1-1/4	3/4, 1, 1-1/4	3/4, 1, 1-1/4
	LOW VOLTAGE CONDUIT KNOCKOUT SIZE (IN.)	1/2	1/2	1/2
	SHIPPING WEIGHT LBS.	360	375	380
	OPERATING WEIGHT LBS.	355	370	375

\*\* When using a 20kW electric heater, unit is rated for 0.5 E.S.P. For all other electric heat sizes as well as units with no heater installed, the max E.S.P is 0.8.

<sup>(1)</sup> Maximum Overcurrent Protection Device: **MUST** use Time Delay Fuse or HACR type Circuit Breaker of the same size as noted.

\* Calculated external filter size based on air velocity of 300 ft/min.

Wire size should be determined in accordance with National Electrical Codes. Extensive wire runs will require larger wire sizes.

Unit specifications are subject to change without notice. **ALWAYS** refer to the units serial plate for the most up-to-date general and electrical information.

**IMPORTANT:** While this data is presented as a guide, it is important to electrically connect the unit and properly size wires and fuses/circuit breakers in accordance with the National Electrical Code and/or all local codes. Data shown is w/o electric heaters.

# COOLING PERFORMANCE DATA

\*PC1424H41AB/B\*/C\*/D\*

## MODEL: \*PC1424H41\*\* EXPANDED PERFORMANCE DATA COOLING OPERATION

Design Subcooling, 9 ± 2°F @ the liquid access fitting connection. AHRI 95 test conditions. Design Superheat 5 ± 2°F @ the compressor suction access fitting connection.

IDB* Airflow	Outdoor Ambient Temperature																								
	65				75				85				95				105				115				
	59	63	67	71	59	63	67	71	59	63	67	71	59	63	67	71	59	63	67	71	59	63	67	71	
70	MBh	24.1	25.0	27.4	-	23.5	24.4	26.7	-	23.0	23.8	26.1	-	22.4	23.2	25.5	-	21.3	22.1	24.2	-	19.7	20.5	22.4	-
	S/T	0.74	0.62	0.43	-	0.77	0.64	0.45	-	0.79	0.66	0.46	-	0.82	0.68	0.47	-	0.85	0.71	0.49	-	0.85	0.71	0.49	-
	Delta T	17	15	11	-	17	15	11	-	17	15	11	-	18	15	12	-	17	15	11	-	16	14	11	-
	KW	1.57	1.60	1.66	-	1.70	1.73	1.79	-	1.81	1.85	1.91	-	1.91	1.95	2.02	-	1.99	2.04	2.11	-	2.06	2.11	2.19	-
	AMPS	6.6	6.8	7.0	-	7.1	7.3	7.5	-	7.7	7.9	8.1	-	8.2	8.4	8.7	-	8.7	8.9	9.2	-	9.2	9.4	9.7	-
	HIPR	233	251	265	-	262	282	298	-	298	321	338	-	339	365	386	-	382	411	434	-	422	454	479	-
	LO PR	111	118	129	-	118	125	137	-	122	130	142	-	128	137	149	-	135	143	156	-	139	148	162	-
	MBh	23.4	24.3	26.6	-	22.9	23.7	26.0	-	22.3	23.1	25.3	-	21.8	22.6	24.7	-	20.7	21.4	23.5	-	19.2	19.9	21.8	-
	S/T	0.71	0.59	0.41	-	0.73	0.61	0.42	-	0.75	0.63	0.44	-	0.78	0.65	0.45	-	0.81	0.67	0.47	-	0.81	0.68	0.47	-
	Delta T	18	16	12	-	18	16	12	-	18	16	12	-	18	16	12	-	18	16	12	-	17	15	11	-
KW	1.56	1.59	1.64	-	1.68	1.72	1.78	-	1.79	1.83	1.90	-	1.89	1.93	2.00	-	1.97	2.02	2.09	-	2.05	2.09	2.17	-	
AMPS	6.6	6.7	6.9	-	7.1	7.2	7.5	-	7.7	7.8	8.1	-	8.1	8.3	8.6	-	8.6	8.8	9.1	-	9.1	9.3	9.6	-	
HIPR	231	249	263	-	259	279	295	-	295	317	335	-	336	361	382	-	378	407	429	-	418	449	474	-	
LO PR	110	117	128	-	116	124	135	-	121	129	141	-	127	135	148	-	133	142	155	-	138	147	160	-	
MBh	21.6	22.4	24.5	-	21.1	21.9	24.0	-	20.6	21.3	23.4	-	20.1	20.8	22.8	-	19.1	19.8	21.7	-	17.7	18.3	20.1	-	
S/T	0.68	0.57	0.40	-	0.71	0.59	0.41	-	0.73	0.61	0.42	-	0.75	0.63	0.43	-	0.78	0.65	0.45	-	0.78	0.66	0.45	-	
Delta T	18	16	12	-	18	16	12	-	18	16	12	-	19	16	12	-	18	16	12	-	17	15	11	-	
KW	1.52	1.55	1.60	-	1.64	1.68	1.73	-	1.75	1.79	1.85	-	1.84	1.88	1.95	-	1.92	1.97	2.03	-	1.99	2.04	2.11	-	
AMPS	6.4	6.6	6.8	-	6.9	7.1	7.3	-	7.5	7.6	7.9	-	7.9	8.1	8.4	-	8.4	8.6	8.9	-	8.9	9.1	9.4	-	
HIPR	224	241	255	-	252	271	286	-	286	308	325	-	326	351	370	-	367	394	417	-	405	436	460	-	
LO PR	107	114	124	-	113	120	131	-	117	125	136	-	123	131	143	-	129	137	150	-	134	142	155	-	
75	MBh	24.5	25.2	27.3	29.3	23.9	24.7	26.7	28.6	23.4	24.1	26.0	28.0	22.8	23.5	25.4	27.3	21.7	22.3	24.1	25.9	20.1	20.7	22.4	24.0
	S/T	0.84	0.76	0.57	0.37	0.88	0.78	0.59	0.38	0.90	0.80	0.61	0.39	0.93	0.83	0.63	0.40	0.96	0.86	0.65	0.42	0.97	0.87	0.66	0.42
	Delta T	20	18	15	10	20	19	15	11	20	19	15	11	20	19	15	11	20	18	15	10	19	17	14	10
	KW	1.58	1.62	1.67	1.73	1.71	1.75	1.81	1.87	1.82	1.87	1.93	2.00	1.92	1.97	2.04	2.11	2.01	2.06	2.13	2.20	2.08	2.13	2.20	2.28
	AMPS	6.7	6.8	7.1	7.3	7.2	7.4	7.6	7.9	7.8	8.0	8.2	8.5	8.3	8.5	8.7	9.1	8.8	9.0	9.3	9.6	9.3	9.5	9.8	10.2
	HIPR	236	254	268	279	265	285	301	314	301	324	342	357	343	369	389	406	386	415	438	457	426	458	484	505
	LO PR	112	120	131	139	119	126	138	147	123	131	143	153	130	138	151	160	136	145	158	168	141	150	163	174
	MBh	23.8	24.5	26.5	28.5	23.2	23.9	25.9	27.8	22.7	23.4	25.3	27.1	22.1	22.8	24.7	26.5	21.0	21.7	23.4	25.2	19.5	20.1	21.7	23.3
	S/T	0.81	0.72	0.55	0.35	0.83	0.75	0.57	0.36	0.86	0.77	0.58	0.37	0.88	0.79	0.60	0.38	0.92	0.82	0.62	0.40	0.92	0.83	0.63	0.40
	Delta T	21	19	16	11	21	19	16	11	21	19	16	11	21	19	16	11	21	19	16	11	19	18	15	10
KW	1.57	1.60	1.66	1.71	1.70	1.73	1.79	1.85	1.81	1.85	1.91	1.98	1.91	1.95	2.02	2.09	1.99	2.04	2.11	2.18	2.06	2.11	2.19	2.26	
AMPS	6.6	6.8	7.0	7.2	7.1	7.3	7.5	7.8	7.7	7.9	8.1	8.4	8.2	8.4	8.7	9.0	8.7	8.9	9.2	9.5	9.2	9.4	9.7	10.1	
HIPR	233	251	265	277	262	282	298	310	298	321	339	353	339	365	386	402	382	411	434	452	422	454	479	500	
LO PR	111	118	129	138	118	125	137	145	122	130	142	151	128	137	149	159	135	143	156	166	139	148	162	172	
MBh	22.0	22.6	24.5	26.3	21.5	22.1	23.9	25.7	20.9	21.6	23.3	25.1	20.4	21.0	22.8	24.4	19.4	20.0	21.6	23.2	18.0	18.5	20.0	21.5	
S/T	0.78	0.69	0.53	0.34	0.81	0.72	0.55	0.35	0.83	0.74	0.56	0.36	0.85	0.76	0.58	0.37	0.88	0.79	0.60	0.39	0.89	0.80	0.60	0.39	
Delta T	21	19	16	11	21	20	16	11	21	20	16	11	21	20	16	11	21	20	16	11	20	18	15	10	
KW	1.53	1.56	1.61	1.67	1.65	1.69	1.75	1.81	1.76	1.80	1.86	1.93	1.86	1.90	1.97	2.03	1.94	1.98	2.05	2.12	2.01	2.06	2.13	2.20	
AMPS	6.5	6.6	6.8	7.1	7.0	7.1	7.3	7.6	7.5	7.7	7.9	8.2	8.0	8.2	8.4	8.7	8.5	8.7	9.0	9.3	9.0	9.2	9.5	9.8	
HIPR	226	244	257	268	254	273	289	301	289	311	328	343	329	354	374	390	370	398	421	439	409	440	465	485	
LO PR	108	115	125	134	114	121	133	141	119	126	138	147	125	133	145	154	131	139	152	161	135	144	157	167	

\* IDB: Entering Indoor Dry Bulb Temperature

High and low pressures are measured at the liquid and suction access fittings.

NOTE: Shaded area is ACCA (TVA) conditions

**MODEL: \*PC1424H41\*\***

**EXPANDED PERFORMANCE DATA**

**COOLING OPERATION**

Design Subcooling, 9 ± 2°F @ the liquid access fitting connection AHRI 95 test conditions. Design Superheat 5 ± 2°F @ the compressor suction access fitting connection.

IDB* Airflow	Outdoor Ambient Temperature																													
	65					75					85					95					105					115				
	59	63	67	71	75	59	63	67	71	75	59	63	67	71	75	59	63	67	71	75	59	63	67	71	75	59	63	67	71	75
955	MBh	25.0	25.5	27.2	29.1	24.4	24.9	26.6	28.4	23.8	24.3	26.0	27.8	23.2	23.7	25.3	27.1	22.0	22.5	24.1	25.7	20.4	20.9	22.3	23.8					
	S/T	0.93	0.87	0.71	0.53	0.96	0.90	0.73	0.55	1.00	0.92	0.75	0.56	1.00	0.95	0.78	0.58	1.00	1.00	0.81	0.60	1.00	1.00	0.81	0.61					
	Delta T	22	21	19	15	23	22	19	15	22	22	19	15	22	22	19	15	21	20	17	15	20	20	17	14					
	KW	1.60	1.63	1.69	1.74	1.72	1.76	1.82	1.89	1.84	1.88	1.95	2.01	1.94	1.99	2.05	2.13	2.03	2.02	2.07	2.15	2.22	2.10	2.15	2.22	2.30				
	AMPS	6.8	6.9	7.1	7.4	7.3	7.4	7.7	7.9	7.9	8.0	8.3	8.6	8.4	8.6	8.8	9.1	8.9	9.1	9.4	9.7	9.4	9.6	9.9	10.3					
	HIPR	238	256	271	282	267	288	304	317	304	327	345	360	346	373	393	410	389	419	443	462	430	463	489	510					
	LO PR	114	121	132	140	120	128	139	148	125	133	145	154	131	139	152	162	137	146	159	170	142	151	165	176					
	MBh	24.2	24.8	26.4	28.3	23.7	24.2	25.8	27.6	23.1	23.6	25.2	27.0	22.5	23.0	24.6	26.3	21.4	21.9	23.4	25.0	19.8	20.3	21.6	23.1					
	S/T	0.88	0.83	0.67	0.50	0.92	0.86	0.70	0.52	0.94	0.88	0.72	0.54	0.97	0.91	0.74	0.55	1.00	0.94	0.77	0.57	1.00	0.95	0.77	0.58					
	Delta T	23	22	19	15	23	22	20	16	24	22	20	16	24	24	23	20	24	23	20	16	21	21	18	14					
KW	1.58	1.62	1.67	1.73	1.71	1.75	1.81	1.87	1.82	1.87	1.93	2.00	1.92	1.97	2.04	2.11	2.01	2.06	2.13	2.20	2.08	2.13	2.21	2.28						
AMPS	6.7	6.8	7.1	7.3	7.2	7.4	7.6	7.9	7.8	8.0	8.2	8.5	8.3	8.5	8.8	9.1	8.8	9.0	9.3	9.6	9.3	9.5	9.8	10.2						
HIPR	236	254	268	279	265	285	301	314	301	324	342	357	343	369	390	406	386	415	438	457	426	458	484	505						
LO PR	112	120	131	139	119	126	138	147	123	131	143	153	130	138	151	160	136	145	158	168	141	150	163	174						
MBh	22.4	22.8	24.4	26.1	21.8	22.3	23.8	25.5	21.3	21.8	23.3	24.9	20.8	21.3	22.7	24.3	19.8	20.2	21.6	23.1	18.3	18.7	20.0	21.4						
S/T	0.85	0.80	0.65	0.49	0.88	0.83	0.67	0.50	0.91	0.85	0.69	0.52	0.93	0.88	0.71	0.53	0.97	0.91	0.74	0.55	0.98	0.92	0.75	0.56						
Delta T	24	23	20	16	24	23	20	16	24	23	20	16	24	23	20	16	24	23	20	16	21	21	18	15						
KW	1.54	1.58	1.63	1.68	1.67	1.70	1.76	1.82	1.78	1.82	1.88	1.94	1.87	1.92	1.98	2.05	1.96	2.00	2.07	2.14	2.03	2.07	2.15	2.22						
AMPS	6.5	6.7	6.9	7.1	7.0	7.2	7.4	7.7	7.6	7.8	8.0	8.3	8.1	8.3	8.5	8.8	8.6	8.8	9.0	9.4	9.0	9.3	9.6	9.9						
HIPR	229	246	260	271	257	276	292	304	292	314	332	346	332	358	378	394	374	403	425	443	413	445	470	490						
LO PR	109	116	127	135	115	123	134	143	120	127	139	148	126	134	146	156	132	140	153	163	136	145	158	169						

NOTE: Shaded area reflects AHRI rating conditions

IDB* Airflow	Outdoor Ambient Temperature																													
	65					75					85					95					105					115				
	59	63	67	71	75	59	63	67	71	75	59	63	67	71	75	59	63	67	71	75	59	63	67	71	75	59	63	67	71	75
955	MBh	25.4	25.9	27.1	28.9	24.8	25.3	26.5	28.2	24.2	24.7	25.8	27.6	23.6	24.1	25.2	26.9	22.4	22.9	24.0	25.6	20.8	21.2	22.2	23.7					
	S/T	0.97	0.94	0.85	0.69	1.00	0.97	0.88	0.71	1.00	1.00	0.90	0.73	1.00	1.00	0.93	0.75	1.00	1.00	0.96	0.78	1.00	1.00	0.97	0.79					
	Delta T	24	23	22	19	24	24	22	19	23	24	22	19	23	23	23	19	22	22	22	19	20	20	21	18					
	KW	1.61	1.64	1.70	1.76	1.74	1.78	1.84	1.90	1.86	1.90	1.96	2.03	1.96	2.00	2.07	2.14	2.04	2.09	2.16	2.24	2.12	2.17	2.24	2.32					
	AMPS	6.8	7.0	7.2	7.4	7.3	7.5	7.7	8.0	7.9	8.1	8.4	8.7	8.4	8.6	8.9	9.2	8.9	9.2	9.5	9.8	9.5	9.7	10.0	10.4					
	HIPR	241	259	273	285	270	290	307	320	307	330	349	364	350	376	397	414	393	423	447	466	435	468	494	515					
	LO PR	115	122	133	142	121	129	141	150	126	134	146	156	132	141	154	164	139	148	161	172	143	153	167	177					
	MBh	24.6	25.1	26.3	28.1	24.1	24.5	25.7	27.4	23.5	24.0	25.1	26.8	22.9	23.4	24.5	26.1	21.8	22.2	23.3	24.8	20.2	20.6	21.5	23.0					
	S/T	0.93	0.89	0.81	0.65	0.96	0.93	0.84	0.68	0.98	0.95	0.86	0.70	1.00	0.98	0.88	0.72	1.00	1.00	0.92	0.75	1.00	1.00	0.93	0.75					
	Delta T	25	24	23	20	25	25	23	20	25	25	23	20	25	25	23	20	24	24	23	20	22	22	22	19					
KW	1.60	1.63	1.69	1.74	1.72	1.76	1.82	1.89	1.84	1.88	1.95	2.01	1.94	1.99	2.05	2.13	2.03	2.07	2.15	2.22	2.10	2.15	2.22	2.30						
AMPS	6.8	6.9	7.1	7.4	7.3	7.4	7.7	7.9	7.9	8.0	8.3	8.6	8.4	8.6	8.8	9.1	8.9	9.1	9.4	9.7	9.4	9.6	9.9	10.3						
HIPR	238	256	271	282	267	288	304	317	304	327	345	360	346	373	393	410	389	419	443	462	430	463	489	510						
LO PR	114	121	132	140	120	128	139	148	125	133	145	154	131	139	152	162	137	146	159	170	142	151	165	176						
MBh	22.7	23.2	24.3	25.9	22.2	22.6	23.7	25.3	21.7	22.1	23.2	24.7	21.2	21.6	22.6	24.1	20.1	20.5	21.5	22.9	18.6	19.0	19.9	21.2						
S/T	0.89	0.86	0.78	0.63	0.93	0.89	0.81	0.65	0.95	0.92	0.83	0.67	0.98	0.95	0.85	0.69	1.00	0.98	0.89	0.72	1.00	0.99	0.89	0.72						
Delta T	25	25	23	20	25	25	24	20	25	25	24	20	26	25	24	21	25	25	23	20	23	23	22	19						
KW	1.56	1.59	1.64	1.70	1.68	1.72	1.78	1.84	1.79	1.83	1.90	1.96	1.89	1.93	2.00	2.07	1.97	2.02	2.09	2.16	2.05	2.09	2.17	2.24						
AMPS	6.6	6.7	6.9	7.2	7.1	7.2	7.5	7.7	7.7	7.8	8.1	8.4	8.1	8.3	8.6	8.9	8.6	8.8	9.1	9.4	9.1	9.3	9.6	10.0						
HIPR	231	249	263	274	259	279	295	307	295	317	335	349	336	361	382	398	378	407	429	448	417	449	474	495						
LO PR	110	117	128	136	116	124	135	144	121	129	141	150	127	135	148	157	133	142	155	165	138	147	160	170						

\* NOTE: Shaded area is AHRI Rating Conditions

IDB: Entering Indoor Dry Bulb Temperature  
High and low pressures are measured at the liquid and suction access fittings.

KW = Total system power

AMPS: Unit amps (comp. + evaporator + condenser fan motors)

# COOLING PERFORMANCE DATA

# \*PC1430H41AB/B/C\*/D\*

## MODEL: \*PC1430H41\*\* EXPANDED PERFORMANCE DATA COOLING OPERATION

Design Subcooling, 10 ± 2 °F @ the liquid access fitting connection ARI 95 test conditions. Design Superheat 10 ± 2 °F @ the compressor suction access fitting connection.

IDB*	Airflow	Outdoor Ambient Temperature																									
		65				75				85				95				105				115					
		59	63	67	71	59	63	67	71	59	63	67	71	59	63	67	71	59	63	67	71	59	63	67	71		
70	1180	MBh	27.8	28.8	31.6	-	27.2	28.2	30.9	-	26.5	27.5	30.1	-	25.9	26.8	29.4	-	24.6	25.5	27.9	-	22.8	23.6	25.9	-	
		S/T	0.76	0.63	0.44	-	0.79	0.66	0.46	-	0.81	0.67	0.47	-	0.83	0.70	0.48	-	0.87	0.72	0.50	-	0.87	0.73	0.50	-	
	1050	Delta T	16	14	11	-	17	14	11	-	17	14	11	-	17	15	11	-	17	14	11	-	15	13	10	-	
		KW	1.86	1.90	1.96	-	2.01	2.06	2.12	-	2.14	2.19	2.27	-	2.26	2.31	2.39	-	2.36	2.41	2.50	-	2.44	2.50	2.59	-	
	920	AMPS	7.7	7.9	8.1	-	8.3	8.5	8.7	-	8.9	9.1	9.4	-	9.5	9.7	10.0	-	10.1	10.3	10.7	-	10.7	10.9	11.3	-	
		HI PR	240	258	272	-	269	289	305	-	306	329	347	-	348	375	396	-	392	421	445	-	433	466	492	-	
	75	1180	LO PR	111	119	129	-	118	125	137	-	122	130	142	-	128	137	149	-	135	143	156	-	139	148	162	-
			MBh	27.0	28.0	30.7	-	26.4	27.4	30.0	-	25.8	26.7	29.3	-	25.1	26.1	28.5	-	23.9	24.7	27.1	-	22.1	22.9	25.1	-
		1050	S/T	0.73	0.61	0.42	-	0.75	0.63	0.43	-	0.77	0.64	0.45	-	0.80	0.66	0.46	-	0.83	0.69	0.48	-	0.83	0.70	0.48	-
			Delta T	17	15	11	-	17	15	11	-	17	15	11	-	18	15	11	-	17	15	11	-	16	14	11	-
920		KW	1.84	1.89	1.95	-	1.99	2.04	2.11	-	2.12	2.17	2.25	-	2.24	2.29	2.37	-	2.34	2.39	2.47	-	2.42	2.48	2.56	-	
		AMPS	7.6	7.8	8.0	-	8.2	8.4	8.6	-	8.9	9.1	9.3	-	9.4	9.6	10.0	-	10.0	10.2	10.6	-	10.6	10.8	11.2	-	
75		1180	HI PR	237	255	269	-	266	286	302	-	303	326	344	-	345	371	392	-	388	417	441	-	428	461	487	-
			LO PR	110	117	128	-	117	124	135	-	121	129	141	-	127	135	148	-	133	142	155	-	138	147	160	-
		1050	MBh	24.9	25.8	28.3	-	24.4	25.2	27.7	-	23.8	24.6	27.0	-	23.2	24.0	26.3	-	22.0	22.8	25.0	-	20.4	21.2	23.2	-
			S/T	0.70	0.58	0.40	-	0.72	0.61	0.42	-	0.74	0.62	0.43	-	0.77	0.64	0.44	-	0.80	0.66	0.46	-	0.80	0.67	0.46	-
	920	Delta T	17	15	11	-	18	15	12	-	18	15	12	-	18	15	12	-	18	15	12	-	16	14	11	-	
		KW	1.80	1.84	1.90	-	1.94	1.99	2.05	-	2.07	2.12	2.19	-	2.18	2.23	2.31	-	2.28	2.33	2.41	-	2.36	2.41	2.50	-	
	75	1180	AMPS	7.4	7.6	7.8	-	8.0	8.2	8.4	-	8.6	8.8	9.1	-	9.2	9.4	9.7	-	9.7	10.0	10.3	-	10.3	10.5	10.9	-
			HI PR	230	248	261	-	258	278	293	-	294	316	334	-	334	360	380	-	376	405	427	-	416	447	472	-
		1050	LO PR	107	114	124	-	113	120	131	-	117	125	136	-	123	131	143	-	129	138	150	-	134	142	155	-
			MBh	28.3	29.1	31.5	33.9	27.6	28.5	30.8	33.1	27.0	27.8	30.1	32.3	26.3	27.1	29.3	31.5	25.0	25.8	27.9	29.9	23.2	23.9	25.8	27.7
920		S/T	0.86	0.77	0.58	0.38	0.90	0.80	0.61	0.39	0.92	0.82	0.62	0.40	0.95	0.85	0.64	0.41	0.98	0.88	0.67	0.43	0.99	0.89	0.67	0.43	
		Delta T	19	18	14	10	19	18	15	10	19	18	15	10	19	18	15	10	19	18	14	10	18	16	14	9	
75		1180	KW	1.88	1.92	1.98	2.05	2.03	2.07	2.14	2.22	2.16	2.21	2.29	2.36	2.28	2.33	2.41	2.49	2.38	2.43	2.52	2.61	2.47	2.52	2.61	2.70
			AMPS	7.8	7.9	8.2	8.5	8.3	8.5	8.8	9.1	9.0	9.2	9.5	9.8	9.6	9.8	10.1	10.5	10.2	10.4	10.7	11.1	10.8	11.0	11.4	11.8
		1050	HI PR	242	260	275	287	272	292	309	322	309	332	351	366	352	378	400	417	396	426	450	469	437	470	497	518
			LO PR	113	120	131	139	119	126	138	147	124	131	143	153	130	138	151	161	136	145	158	168	141	150	163	174
	920	MBh	27.5	28.3	30.6	32.9	26.8	27.6	29.9	32.1	26.2	27.0	29.2	31.3	25.6	26.3	28.5	30.6	24.3	25.0	27.1	29.0	22.5	23.2	25.1	26.9	
		S/T	0.82	0.74	0.56	0.36	0.85	0.76	0.58	0.37	0.88	0.78	0.59	0.38	0.90	0.81	0.61	0.39	0.94	0.84	0.64	0.41	0.95	0.85	0.64	0.41	
	75	1050	Delta T	20	18	15	10	20	18	15	10	20	19	15	10	20	19	15	10	20	18	15	10	19	17	14	10
			KW	1.86	1.90	1.96	2.03	2.01	2.06	2.12	2.20	2.14	2.19	2.27	2.34	2.26	2.31	2.39	2.47	2.36	2.41	2.50	2.58	2.44	2.50	2.59	2.68
		920	AMPS	7.7	7.9	8.1	8.4	8.3	8.5	8.7	9.0	8.9	9.1	9.4	9.8	9.5	9.7	10.0	10.4	10.1	10.3	10.7	11.0	10.7	10.9	11.3	11.7
			HI PR	240	258	272	284	269	289	305	319	306	329	347	362	348	375	396	413	392	422	445	464	433	466	492	513
75		LO PR	111	119	129	138	118	125	137	146	122	130	142	151	128	137	149	159	135	143	156	167	139	148	162	172	
		MBh	25.4	26.1	28.3	30.3	24.8	25.5	27.6	29.6	24.2	24.9	26.9	28.9	23.6	24.3	26.3	28.2	22.4	23.1	25.0	26.8	20.8	21.4	23.1	24.8	
75		S/T	0.79	0.71	0.54	0.35	0.82	0.74	0.56	0.36	0.84	0.76	0.57	0.37	0.87	0.78	0.59	0.38	0.90	0.81	0.61	0.39	0.91	0.82	0.62	0.40	
		Delta T	20	19	15	10	20	19	15	11	20	19	15	11	21	19	16	11	20	19	15	11	19	17	14	10	
75		KW	1.81	1.85	1.92	1.98	1.96	2.00	2.07	2.14	2.09	2.14	2.21	2.28	2.20	2.25	2.33	2.41	2.30	2.35	2.43	2.52	2.38	2.44	2.52	2.61	
		AMPS	7.5	7.7	7.9	8.2	8.1	8.2	8.5	8.8	8.7	8.9	9.2	9.5	9.3	9.5	9.8	10.1	9.8	10.1	10.4	10.7	10.4	10.6	11.0	11.4	
75	HI PR	232	250	264	275	261	281	296	309	297	319	337	351	338	363	384	400	380	409	432	450	420	452	477	498		
	LO PR	108	115	126	134	114	121	133	141	119	126	138	147	125	133	145	154	131	139	152	162	135	144	157	167		

\* IDB: Entering Indoor Dry Bulb Temperature NOTE: Shaded area is ACCA (TVA) conditions

High and low pressures are measured at the liquid and suction access fittings.



Design Subcooling, 10 ± 2 °F @ the liquid access fitting connection ARI 95 test conditions. Design Superheat 10 ± 2 °F @ the compressor suction access fitting connection.

IDB*	Airflow	Outdoor Ambient Temperature																													
		65					75					85					95					105					115				
		59	63	67	71	75	59	63	67	71	75	59	63	67	71	75	59	63	67	71	75	59	63	67	71	75	59	63	67	71	75
80	1180	MBh	28.8	29.4	31.4	33.6	28.1	28.7	30.7	32.8	27.5	28.1	30.0	32.1	26.8	27.4	29.3	31.3	25.5	26.0	27.8	29.7	23.6	24.1	25.7	27.5					
		S/T	0.95	0.89	0.72	0.54	1.00	0.92	0.75	0.56	1.00	0.94	0.77	0.57	1.00	1.00	0.79	0.59	1.00	1.00	0.82	0.62	1.00	1.00	0.83	0.62					
		Delta T	21	20	18	14	22	21	18	14	21	21	18	14	21	21	18	14	20	20	18	14	18	19	17	13					
		KW	1.89	1.93	2.00	2.07	2.04	2.09	2.16	2.23	2.18	2.23	2.30	2.38	2.30	2.35	2.43	2.52	2.40	2.46	2.54	2.63	2.49	2.55	2.63	2.73					
		AMPS	7.8	8.0	8.2	8.5	8.4	8.6	8.9	9.2	9.1	9.3	9.6	9.9	9.7	9.9	10.2	10.6	10.3	10.5	10.8	11.2	10.9	11.1	11.5	11.9					
	1050	HIPR	244	263	278	290	274	295	312	325	312	336	354	370	355	382	404	421	400	430	454	474	442	475	502	523					
		LO PR	114	121	132	141	120	128	139	149	125	133	145	154	131	139	152	162	137	146	160	170	142	151	165	176					
		MBh	28.0	28.6	30.5	32.6	27.3	27.9	29.8	31.9	26.7	27.2	29.1	31.1	26.0	26.6	28.4	30.4	24.7	25.3	27.0	28.8	22.9	23.4	25.0	26.7					
		S/T	0.90	0.85	0.69	0.52	0.94	0.88	0.72	0.53	0.96	0.90	0.73	0.55	0.99	0.93	0.76	0.57	1.00	0.97	0.79	0.59	1.00	0.97	0.79	0.59					
		Delta T	22	21	18	15	22	21	19	15	22	21	19	15	23	22	19	15	22	21	19	15	20	20	17	14					
920	KW	1.88	1.92	1.98	2.05	2.03	2.07	2.14	2.22	2.16	2.21	2.29	2.36	2.28	2.33	2.41	2.49	2.38	2.43	2.52	2.61	2.47	2.52	2.61	2.70						
	AMPS	7.8	7.9	8.2	8.5	8.3	8.5	8.8	9.1	9.0	9.2	9.5	9.8	9.6	9.8	10.1	10.5	10.2	10.4	10.7	11.1	10.8	11.0	11.4	11.8						
	HIPR	242	260	275	287	272	292	309	322	309	332	351	366	352	379	400	417	396	426	450	469	437	470	497	518						
	LO PR	113	120	131	139	119	126	138	147	124	131	144	153	130	138	151	161	136	145	158	168	141	150	163	174						
	MBh	25.8	26.4	28.2	30.1	25.2	25.8	27.5	29.4	24.6	25.1	26.9	28.7	24.0	24.5	26.2	28.0	22.8	23.3	24.9	26.6	21.1	21.6	23.1	24.7						

NOTE: Shaded area reflects AHRI rating conditions

IDB*	Airflow	Outdoor Ambient Temperature																													
		65					75					85					95					105					115				
		59	63	67	71	75	59	63	67	71	75	59	63	67	71	75	59	63	67	71	75	59	63	67	71	75	59	63	67	71	75
85	1180	MBh	29.3	29.9	31.3	33.4	28.6	29.2	30.6	32.6	27.9	28.5	29.8	31.8	27.3	27.8	29.1	31.1	25.9	26.4	27.7	29.5	24.0	24.5	25.6	27.3					
		S/T	0.99	0.96	0.87	0.70	1.00	0.99	0.90	0.73	1.00	1.00	0.92	0.75	1.00	1.00	0.95	0.77	1.00	1.00	0.99	0.80	1.00	1.00	0.99	0.81					
		Delta T	23	22	21	18	22	23	21	18	22	22	21	18	21	22	22	19	20	21	21	18	19	19	20	17					
		KW	1.91	1.95	2.01	2.08	2.06	2.11	2.18	2.25	2.20	2.25	2.32	2.41	2.32	2.37	2.45	2.54	2.42	2.48	2.56	2.65	2.51	2.57	2.66	2.75					
		AMPS	7.9	8.1	8.3	8.6	8.5	8.7	8.9	9.3	9.2	9.4	9.7	10.0	9.8	10.0	10.3	10.7	10.4	10.6	10.9	11.3	10.9	11.2	11.6	12.0					
	1050	HIPR	247	266	281	293	277	298	315	328	315	339	358	373	359	386	408	425	404	434	459	478	446	480	507	529					
		LO PR	115	122	133	142	121	129	141	150	126	134	146	156	132	141	154	164	139	148	161	172	144	153	167	178					
		MBh	28.5	29.0	30.4	32.4	27.8	28.3	29.7	31.7	27.1	27.7	29.0	30.9	26.5	27.0	28.3	30.1	25.1	25.6	26.8	28.6	23.3	23.7	24.9	26.5					
		S/T	0.95	0.91	0.83	0.67	0.98	0.95	0.86	0.69	1.00	0.97	0.88	0.71	1.00	1.00	0.91	0.73	1.00	1.00	0.94	0.76	1.00	1.00	0.95	0.77					
		Delta T	24	23	22	19	24	24	22	19	24	24	22	19	23	24	22	19	22	22	22	19	20	21	21	18					
920	KW	1.89	1.93	2.00	2.07	2.04	2.09	2.16	2.23	2.18	2.23	2.30	2.38	2.30	2.35	2.43	2.52	2.40	2.46	2.54	2.63	2.49	2.55	2.63	2.73						
	AMPS	7.8	8.0	8.2	8.5	8.4	8.6	8.9	9.2	9.1	9.3	9.6	9.9	9.7	9.9	10.2	10.6	10.3	10.5	10.8	11.2	10.9	11.1	11.5	11.9						
	HIPR	244	263	278	290	274	295	312	325	312	336	354	370	355	382	404	421	400	430	454	474	442	475	502	523						
	LO PR	114	121	132	141	120	128	139	149	125	133	145	154	131	139	152	162	137	146	160	170	142	151	165	176						
	MBh	26.3	26.8	28.0	29.9	25.7	26.1	27.4	29.2	25.0	25.5	26.7	28.5	24.4	24.9	26.1	27.8	23.2	23.7	24.8	26.4	21.5	21.9	23.0	24.5						

\* NOTE: Shaded area is AHRI Rating Conditions

IDB: Entering Indoor Dry Bulb Temperature

KW = Total system power

AMPS: Unit amps (comp. + evaporator + condenser fan motors)

High and low pressures are measured at the liquid and suction access fittings.



# COOLING PERFORMANCE DATA

\*PC1436H41AB/B\*/C\*/D\*

## MODEL: \*PC1436H41\*\* EXPANDED PERFORMANCE DATA COOLING OPERATION

Design Subcooling, 10 ±2 °F @ the liquid access fitting connection ARI 95 test conditions. Design Superheat 9 ±2 °F @ the compressor suction access fitting connection.

IDB*	Airflow	Outdoor Ambient Temperature																													
		65					75					85					95					105					115				
		59	63	67	71	75	59	63	67	71	75	59	63	67	71	75	59	63	67	71	75	59	63	67	71	75	59	63	67	71	75
70	1349	MBh	34.9	36.2	39.6	-	34.1	35.3	38.7	-	33.3	34.5	37.8	-	32.5	33.6	36.9	-	30.8	32.0	35.0	-	28.6	29.6	32.4	-					
		S/T	0.76	0.64	0.44	-	0.79	0.66	0.46	-	0.81	0.68	0.47	-	0.84	0.70	0.48	-	0.87	0.72	0.50	-	0.87	0.73	0.51	-					
		Delta T	18	16	12	-	18	16	12	-	18	16	12	-	18	16	12	-	18	16	12	-	17	15	11	-					
		KW	2.33	2.38	2.45	-	2.51	2.57	2.65	-	2.67	2.73	2.82	-	2.81	2.88	2.97	-	2.93	3.00	3.10	-	3.04	3.11	3.21	-					
		A/MPS	10.5	10.8	11.0	-	11.3	11.5	11.8	-	12.1	12.3	12.7	-	12.8	13.1	13.4	-	13.5	13.8	14.2	-	14.2	14.5	14.9	-					
	1200	HIPR	238	256	271	-	267	288	304	-	304	327	345	-	346	372	393	-	389	419	442	-	430	463	489	-					
		LO PR	107	114	125	-	114	121	132	-	118	126	137	-	124	132	144	-	130	138	151	-	134	143	156	-					
		MBh	33.9	35.1	38.5	-	33.1	34.3	37.6	-	32.3	33.5	36.7	-	31.5	32.7	35.8	-	29.9	31.0	34.0	-	27.7	28.7	31.5	-					
		S/T	0.73	0.61	0.42	-	0.75	0.63	0.44	-	0.77	0.64	0.45	-	0.80	0.67	0.46	-	0.83	0.69	0.48	-	0.83	0.70	0.48	-					
		Delta T	19	16	12	-	19	17	13	-	19	17	13	-	19	17	13	-	19	16	12	-	18	15	12	-					
1052	KW	2.31	2.36	2.43	-	2.49	2.54	2.63	-	2.65	2.71	2.80	-	2.79	2.85	2.95	-	2.91	2.97	3.07	-	3.01	3.08	3.18	-						
	A/MPS	10.5	10.7	11.0	-	11.2	11.4	11.7	-	12.0	12.2	12.6	-	12.7	12.9	13.3	-	13.4	13.7	14.1	-	14.1	14.4	14.8	-						
	HIPR	236	254	268	-	265	285	301	-	301	324	342	-	343	369	389	-	386	415	438	-	426	458	484	-						
	LO PR	106	113	124	-	112	120	131	-	117	124	136	-	123	131	143	-	129	137	149	-	133	142	155	-						
	MBh	31.3	32.4	35.5	-	30.5	31.6	34.7	-	29.8	30.9	33.8	-	29.1	30.1	33.0	-	27.6	28.6	31.4	-	25.6	26.5	29.1	-						
75	1349	S/T	0.70	0.58	0.41	-	0.73	0.61	0.42	-	0.74	0.62	0.43	-	0.77	0.64	0.44	-	0.80	0.67	0.46	-	0.80	0.67	0.47	-					
		Delta T	19	17	13	-	19	17	13	-	19	17	13	-	20	17	13	-	19	17	13	-	18	16	12	-					
		KW	2.25	2.30	2.37	-	2.43	2.48	2.56	-	2.58	2.64	2.73	-	2.72	2.78	2.87	-	2.84	2.90	3.00	-	2.94	3.00	3.10	-					
		A/MPS	10.2	10.4	10.7	-	10.9	11.1	11.4	-	11.7	11.9	12.3	-	12.4	12.6	13.0	-	13.1	13.3	13.7	-	13.7	14.0	14.4	-					
		HIPR	229	246	260	-	257	276	292	-	292	314	332	-	332	358	378	-	374	402	425	-	413	445	470	-					
	1200	LO PR	103	110	120	-	109	116	127	-	113	121	132	-	119	127	138	-	125	133	145	-	129	137	150	-					
		MBh	35.5	36.5	39.5	42.4	34.7	35.7	38.6	41.4	33.8	34.8	37.7	40.5	33.0	34.0	36.8	39.5	31.4	32.3	34.9	37.5	29.0	29.9	32.4	34.7					
		S/T	0.87	0.77	0.59	0.38	0.90	0.80	0.61	0.39	0.92	0.82	0.62	0.40	0.95	0.85	0.64	0.41	0.99	0.88	0.67	0.43	0.99	0.89	0.67	0.43					
		Delta T	21	19	16	11	21	20	16	11	21	20	16	11	21	20	16	11	21	19	16	11	20	18	15	10					
		KW	2.35	2.40	2.47	2.56	2.53	2.59	2.67	2.76	2.69	2.75	2.84	2.94	2.84	2.90	3.00	3.10	2.96	3.03	3.13	3.24	3.06	3.13	3.24	3.35					
1052	A/MPS	10.6	10.8	11.1	11.5	11.3	11.6	11.9	12.3	12.2	12.4	12.8	13.2	12.9	13.2	13.5	14.0	13.6	13.9	14.3	14.8	14.3	14.6	15.1	15.6						
	HIPR	241	259	273	285	270	290	307	320	307	330	349	364	350	376	397	414	393	423	447	466	435	468	494	515						
	LO PR	109	116	126	134	115	122	133	142	119	127	138	147	125	133	145	155	131	140	152	162	136	144	158	168						
	MBh	34.4	35.5	38.4	41.2	33.6	34.6	37.5	40.2	32.8	33.8	36.6	39.3	32.0	33.0	35.7	38.3	30.4	31.3	33.9	36.4	28.2	29.0	31.4	33.7						
	S/T	0.83	0.74	0.56	0.36	0.86	0.77	0.58	0.37	0.88	0.78	0.59	0.38	0.91	0.81	0.61	0.39	0.94	0.84	0.64	0.41	0.95	0.85	0.64	0.41						
70	1349	Delta T	22	20	16	11	22	20	17	11	22	20	17	11	22	20	17	12	22	20	17	11	20	19	15	11					
		KW	2.33	2.38	2.45	2.54	2.51	2.57	2.65	2.74	2.67	2.73	2.82	2.92	2.81	2.88	2.97	3.07	2.93	3.00	3.10	3.21	3.04	3.11	3.21	3.32					
		A/MPS	10.5	10.8	11.0	11.4	11.3	11.5	11.8	12.2	12.1	12.3	12.7	13.1	12.8	13.1	13.4	13.9	13.5	13.8	14.2	14.7	14.2	14.5	14.9	15.4					
		HIPR	238	256	271	282	267	288	304	317	304	327	345	360	346	373	393	410	389	419	443	462	430	463	489	510					
		LO PR	107	114	125	133	114	121	132	140	118	126	137	146	124	132	144	153	130	138	151	161	134	143	156	166					
	1200	MBh	31.8	32.7	35.4	38.0	31.1	32.0	34.6	37.1	30.3	31.2	33.8	36.3	29.6	30.4	33.0	35.4	28.1	28.9	31.3	33.6	26.0	26.8	29.0	31.1					
		S/T	0.80	0.71	0.54	0.35	0.83	0.74	0.56	0.36	0.85	0.76	0.57	0.37	0.87	0.78	0.59	0.38	0.91	0.81	0.61	0.39	0.91	0.82	0.62	0.40					
		Delta T	22	20	17	12	22	21	17	12	22	21	17	12	23	21	17	12	22	21	17	12	21	19	16	11					
		KW	2.27	2.32	2.39	2.47	2.45	2.50	2.58	2.67	2.60	2.66	2.75	2.84	2.74	2.80	2.90	2.99	2.86	2.92	3.02	3.12	2.96	3.03	3.13	3.24					
		A/MPS	10.3	10.5	10.8	11.1	11.0	11.2	11.5	11.9	11.8	12.0	12.4	12.8	12.5	12.7	13.1	13.5	13.2	13.4	13.8	14.3	13.8	14.1	14.6	15.0					
1052	HIPR	231	249	263	274	259	279	295	307	295	317	335	349	336	361	382	398	378	407	429	448	417	449	474	495						
	LO PR	104	111	121	129	110	117	128	136	114	122	133	142	120	128	140	149	126	134	146	156	130	139	151	161						

\* IDB: Entering Indoor Dry Bulb Temperature NOTE: Shaded area is ACCA (TV A) conditions

High and low pressures are measured at the liquid and suction access fittings.

MODEL: \*PC1436H41\*\*

EXPANDED PERFORMANCE DATA

COOLING OPERATION

Design Subcooling, 10 ±2 °F @ the liquid access fitting connection ARI 95 test conditions. Design Superheat 9 ±2 °F @ the compressor suction access fitting connection.

		65					75					85					95					105					115						
IDB*	Airflow	59	63	67	71	75	59	63	67	71	75	59	63	67	71	75	59	63	67	71	75	59	63	67	71	75	59	63	67	71	75		
80	1349	MBh	36.1	36.9	39.4	42.1	35.3	36.0	38.5	41.2	34.4	35.2	37.6	40.2	33.6	34.3	36.7	39.2	31.9	32.6	34.8	37.2	29.6	30.2	32.3	34.5	29.6	30.2	32.3	34.5	36.7		
		S/T	0.95	0.89	0.72	0.54	1.00	0.92	0.75	0.56	1.00	0.95	0.77	0.58	1.00	1.00	0.80	0.59	1.00	1.00	0.83	0.62	1.00	1.00	0.83	0.62	1.00	1.00	0.83	0.62	0.83		
	1200	Delta T	23	22	19	16	24	23	20	16	23	23	20	16	23	23	20	16	23	22	19	16	20	21	18	15	20	21	18	15	15		
		KW	2.37	2.42	2.50	2.58	2.55	2.61	2.69	2.78	2.72	2.78	2.87	2.97	2.86	2.93	3.02	3.13	2.98	3.05	3.15	3.26	3.09	3.16	3.27	3.38	3.09	3.16	3.27	3.38	3.49		
	1052	AMPS	10.7	10.9	11.2	11.6	11.4	11.7	12.0	12.4	12.3	12.5	12.9	13.3	13.0	13.3	13.6	14.1	13.7	14.0	14.4	14.9	14.4	14.7	15.2	15.7	14.4	14.7	15.2	15.7	16.8		
		HIPR	243	261	276	288	273	293	310	323	310	334	352	368	353	380	401	419	397	428	451	471	439	472	499	520	439	472	499	520	570		
	85	1349	LO PR	110	117	127	136	116	123	135	143	120	128	140	149	126	135	147	156	133	141	154	164	137	146	159	170	137	146	159	170	180	
			MBh	35.1	35.8	38.3	40.9	34.2	35.0	37.4	40.0	33.4	34.2	36.5	39.0	32.6	33.3	35.6	38.1	31.0	31.7	33.8	36.2	28.7	29.3	31.3	33.5	28.7	29.3	31.3	33.5	35.6	
		1200	S/T	0.91	0.85	0.69	0.52	0.94	0.88	0.72	0.54	0.96	0.90	0.73	0.55	0.99	0.93	0.76	0.57	1.00	0.97	0.79	0.59	1.00	0.97	0.79	0.59	1.00	0.97	0.79	0.59	0.79	
			Delta T	24	23	20	16	25	24	21	16	25	24	21	16	25	24	21	16	25	24	21	16	22	22	19	15	22	22	19	15	15	
1052		KW	2.35	2.40	2.48	2.56	2.53	2.59	2.67	2.76	2.69	2.75	2.84	2.94	2.84	2.90	3.00	3.10	2.96	3.03	3.13	3.24	3.06	3.13	3.24	3.35	3.06	3.13	3.24	3.35	3.46		
		AMPS	10.6	10.8	11.1	11.5	11.3	11.6	11.9	12.3	12.2	12.4	12.8	13.2	12.9	13.2	13.5	14.0	13.6	13.9	14.3	14.8	14.3	14.6	15.1	15.6	14.3	14.6	15.1	15.6	16.7		
85		1349	HIPR	241	259	273	285	270	290	307	320	307	330	349	364	350	376	397	414	393	423	447	466	435	468	494	515	435	468	494	515	566	
			LO PR	109	116	126	134	115	122	133	142	119	127	138	147	125	133	145	155	131	140	152	162	136	144	158	168	136	144	158	168	179	
		1200	MBh	32.4	33.1	35.3	37.8	31.6	32.3	34.5	36.9	30.9	31.5	33.7	36.0	30.1	30.8	32.9	35.1	28.6	29.2	31.2	33.4	26.5	27.1	28.9	30.9	26.5	27.1	28.9	30.9	32.0	
			S/T	0.87	0.82	0.67	0.50	0.90	0.85	0.69	0.52	0.93	0.87	0.71	0.53	0.96	0.90	0.73	0.55	0.99	0.93	0.76	0.57	1.00	0.94	0.77	0.57	1.00	0.94	0.77	0.57	0.57	
	1052	Delta T	25	24	21	16	25	24	21	17	25	24	21	17	25	24	21	17	25	24	21	17	23	22	19	15	23	22	19	15	15		
		KW	2.29	2.34	2.41	2.49	2.47	2.52	2.60	2.69	2.63	2.68	2.77	2.87	2.77	2.83	2.92	3.02	2.88	2.95	3.05	3.15	2.99	3.05	3.16	3.26	2.99	3.05	3.16	3.26	3.37		
	85	1349	AMPS	10.4	10.6	10.9	11.2	11.1	11.3	11.6	12.0	11.9	12.1	12.5	12.9	12.6	12.8	13.2	13.6	13.3	13.6	14.0	14.4	14.0	14.3	14.7	15.2	14.0	14.3	14.7	15.2	16.3	
			HIPR	233	251	265	277	262	282	298	310	298	320	338	353	339	365	385	402	382	411	434	452	422	454	479	500	422	454	479	500	551	
		1200	LO PR	105	112	122	130	111	118	129	138	116	123	134	143	121	129	141	150	127	135	148	157	132	140	153	163	132	140	153	163	174	
			MBh	36.7	37.4	39.2	41.8	35.9	36.6	38.3	40.9	35.0	35.7	37.4	39.9	34.2	34.8	36.5	38.9	32.5	33.1	34.7	37.0	30.1	30.7	32.1	34.3	30.1	30.7	32.1	34.3	35.4	
1052		S/T	1.00	0.96	0.87	0.70	1.00	1.00	0.90	0.73	1.00	1.00	0.92	0.75	1.00	1.00	0.95	0.77	1.00	1.00	0.99	0.80	1.00	1.00	0.99	0.80	1.00	1.00	0.99	0.80	0.81		
		Delta T	25	25	23	20	24	25	23	20	24	24	23	20	23	24	24	20	22	23	23	20	21	21	22	19	21	21	22	19	19		
85		1349	KW	2.39	2.44	2.52	2.60	2.57	2.63	2.72	2.81	2.74	2.80	2.89	2.99	2.89	2.95	3.05	3.15	3.01	3.08	3.18	3.29	3.12	3.19	3.30	3.41	3.12	3.19	3.30	3.41	3.52	
			AMPS	10.8	11.0	11.3	11.7	11.5	11.8	12.1	12.5	12.4	12.6	13.0	13.4	13.1	13.4	13.8	14.2	13.8	14.1	14.5	15.0	14.5	14.9	15.3	15.8	14.5	14.9	15.3	15.8	16.9	
		1200	HIPR	245	264	279	291	275	296	313	326	313	337	356	371	357	384	405	423	401	432	456	476	443	477	504	525	443	477	504	525	576	
			LO PR	111	118	129	137	117	124	136	145	122	129	141	150	128	136	148	158	134	142	155	166	138	147	161	171	138	147	161	171	182	
	1052	MBh	35.7	36.4	38.1	40.6	34.8	35.5	37.2	39.7	34.0	34.7	36.3	38.7	33.2	33.8	35.4	37.8	31.5	32.1	33.7	35.9	29.2	29.8	31.2	33.3	29.2	29.8	31.2	33.3	34.4		
		S/T	0.95	0.92	0.83	0.67	0.98	0.95	0.86	0.70	1.00	0.97	0.88	0.71	1.00	1.00	0.91	0.74	1.00	1.00	0.94	0.76	1.00	1.00	0.95	0.77	1.00	1.00	0.95	0.77	0.77		
	85	1200	Delta T	26	26	24	21	26	26	24	21	26	26	24	21	25	26	25	21	24	25	24	21	22	23	20	20	22	23	23	20	20	
			KW	2.37	2.42	2.50	2.58	2.55	2.61	2.69	2.78	2.72	2.78	2.87	2.97	2.86	2.93	3.02	3.13	2.98	3.05	3.15	3.26	3.09	3.16	3.27	3.38	3.09	3.16	3.27	3.38	3.49	
		1052	AMPS	10.7	10.9	11.2	11.6	11.4	11.7	12.0	12.4	12.3	12.5	12.9	13.3	13.0	13.3	13.6	14.1	13.7	14.0	14.4	14.9	14.4	14.7	15.2	15.7	14.4	14.7	15.2	15.7	16.8	
			HIPR	243	261	276	288	273	293	310	323	310	334	352	368	353	380	401	419	397	428	451	471	439	472	499	520	439	472	499	520	571	
85		1200	LO PR	110	117	127	136	116	123	135	143	120	128	140	149	126	135	147	156	133	141	154	164	137	146	159	170	137	146	159	170	181	
			MBh	32.9	33.6	35.1	37.5	32.2	32.8	34.3	36.6	31.4	32.0	33.5	35.8	30.6	31.2	32.7	34.9	29.1	29.7	31.1	33.1	26.9	27.5	28.8	30.7	26.9	27.5	28.8	30.7	31.8	
		1052	S/T	0.92	0.88	0.80	0.65	0.95	0.92	0.83	0.67	0.97	0.94	0.85	0.69	1.00	0.97	0.87	0.71	1.00	1.00	0.91	0.74	1.00	1.00	0.92	0.74	1.00	1.00	0.92	0.74	0.74	
			Delta T	26	26	24	21	27	26	25	21	27	26	25	21	27	26	25	22	25	26	25	22	24	24	23	20	24	24	23	20	20	
		85	1052	KW	2.31	2.36	2.43	2.51	2.49	2.54	2.63	2.71	2.65	2.71	2.80	2.89	2.79	2.85	2.95	3.05	2.91	2.97	3.07	3.18	3.01	3.08	3.18	3.29	3.01	3.08	3.18	3.29	3.40
				AMPS	10.5	10.7	11.0	11.3	11.2	11.4	11.7	12.1	12.0	12.2	12.6	13.0	12.7	12.9	13.3	13.8	13.4	13.7	14.1	14.5	14.1	14.4	14.8	15.3	14.1	14.4	14.8	15.3	16.4
	1052		HIPR	236	254	268	279	264	285	301	313	301	324	342	356	343	369	389	406	385	415	438	457	426	458	484	505	426	458	484	505	556	
			LO PR	106	113	124	132	112	120	131	139	117	124	136	144	123	131	142	152	129	137	149	159	133	141	154	165	133	141	154	165	176	

NOTE: Shaded area reflects AHR1 rating conditions

\* NOTE: Shaded areas is AHR1 Rating Conditions IDB: Entering Indoor Dry Bulb Temperature KW = Total system power

High and low pressures are measured at the liquid and suction access fittings.

AMPS: Unit amps (comp. + evaporator + condenser fan motors)

COOLING PERFORMANCE DATA

\*PC1436H41AB/B\*/C\*/D\*

# COOLING PERFORMANCE DATA

\*PC1442H41AB/B\*/C\*/D\*

## MODEL: \*PC1442H41\*\* EXPANDED PERFORMANCE DATA COOLING OPERATION

Design Subcooling, 8 ± 2 °F @ the liquid access fitting connection AHRI 95 test conditions. Design Superheat 8 ± 2 °F @ the compressor suction access fitting connection.

		Outdoor Ambient Temperature																							
		65				75				85				95				105				115			
IDB*	Airflow	59	63	67	71	59	63	67	71	59	63	67	71	59	63	67	71	59	63	67	71	59	63	67	71
70	MBh	39.7	41.1	45.1	-	38.8	40.2	44.0	-	37.8	39.2	43.0	-	36.9	38.3	41.9	-	35.1	36.4	39.8	-	32.5	33.7	36.9	-
	S/T	0.75	0.63	0.43	-	0.78	0.65	0.45	-	0.80	0.67	0.46	-	0.82	0.69	0.48	-	0.86	0.71	0.49	-	0.86	0.72	0.50	-
	Delta T	19	16	12	-	19	16	12	-	19	16	12	-	19	17	13	-	19	16	12	-	18	15	12	-
	KW	2.54	2.60	2.68	-	2.74	2.80	2.89	-	2.92	2.98	3.08	-	3.07	3.14	3.25	-	3.21	3.28	3.39	-	3.32	3.40	3.51	-
	A/MPs	11.6	11.8	12.1	-	12.4	12.6	13.0	-	13.3	13.6	14.0	-	14.1	14.4	14.9	-	14.9	15.3	15.7	-	15.7	16.1	16.6	-
	HI/PR	236	254	268	-	265	285	301	-	301	324	342	-	343	369	390	-	386	415	439	-	426	459	485	-
	LO PR	110	116	127	-	116	123	134	-	120	128	140	-	126	134	147	-	132	141	154	-	137	146	159	-
	MBh	38.5	39.9	43.8	-	37.6	39.0	42.7	-	36.7	38.1	41.7	-	35.8	37.1	40.7	-	34.1	35.3	38.7	-	31.5	32.7	35.8	-
	S/T	0.72	0.60	0.41	-	0.74	0.62	0.43	-	0.76	0.64	0.44	-	0.79	0.66	0.45	-	0.82	0.68	0.47	-	0.82	0.69	0.48	-
	Delta T	20	17	13	-	20	17	13	-	20	17	13	-	20	17	13	-	20	17	13	-	18	16	12	-
75	KW	2.52	2.58	2.66	-	2.72	2.78	2.87	-	2.89	2.96	3.06	-	3.05	3.12	3.22	-	3.18	3.25	3.36	-	3.29	3.37	3.48	-
	A/MPs	11.5	11.7	12.0	-	12.3	12.5	12.9	-	13.2	13.5	13.9	-	14.0	14.3	14.7	-	14.8	15.1	15.6	-	15.6	15.9	16.4	-
	HI/PR	234	251	266	-	262	282	298	-	298	321	339	-	340	366	386	-	382	411	434	-	422	454	480	-
	LO PR	108	115	126	-	115	122	133	-	119	127	138	-	125	133	145	-	131	139	152	-	136	144	157	-
	MBh	35.6	36.9	40.4	-	34.7	36.0	39.4	-	33.9	35.1	38.5	-	33.1	34.3	37.6	-	31.4	32.6	35.7	-	29.1	30.2	33.1	-
	S/T	0.69	0.58	0.40	-	0.72	0.60	0.41	-	0.73	0.61	0.42	-	0.76	0.63	0.44	-	0.79	0.66	0.46	-	0.79	0.66	0.46	-
	Delta T	20	17	13	-	20	17	13	-	20	17	13	-	20	18	13	-	20	17	13	-	19	16	12	-
	KW	2.46	2.51	2.59	-	2.65	2.71	2.80	-	2.82	2.88	2.98	-	2.97	3.04	3.14	-	3.10	3.17	3.27	-	3.21	3.28	3.39	-
	A/MPs	11.2	11.4	11.8	-	12.0	12.2	12.6	-	12.9	13.2	13.5	-	13.7	14.0	14.4	-	14.4	14.8	15.2	-	15.2	15.5	16.0	-
	HI/PR	227	244	258	-	254	274	289	-	289	311	329	-	329	355	374	-	371	399	421	-	410	441	465	-
LO PR	105	112	122	-	111	118	129	-	115	123	134	-	121	129	141	-	127	135	148	-	131	140	153	-	
1461	MBh	40.4	41.6	45.0	48.3	39.4	40.6	43.9	47.2	38.5	39.6	42.9	46.0	37.5	38.7	41.8	44.9	35.7	36.7	39.7	42.7	33.0	34.0	36.8	39.5
	S/T	0.85	0.76	0.58	0.37	0.88	0.79	0.60	0.39	0.91	0.81	0.61	0.40	0.94	0.84	0.63	0.41	0.97	0.87	0.66	0.42	0.98	0.88	0.66	0.43
	Delta T	22	20	16	11	22	20	17	11	22	20	17	11	22	20	17	12	22	20	16	11	20	19	15	11
	KW	2.56	2.62	2.70	2.79	2.77	2.83	2.92	3.02	2.94	3.01	3.11	3.21	3.10	3.17	3.28	3.39	3.23	3.31	3.42	3.54	3.35	3.43	3.54	3.66
	A/MPs	11.7	11.9	12.2	12.6	12.5	12.7	13.1	13.5	13.4	13.7	14.1	14.6	14.2	14.5	15.0	15.5	15.1	15.4	15.8	16.4	15.9	16.2	16.7	17.3
	HI/PR	238	257	271	283	268	288	304	317	304	327	346	361	347	373	394	411	390	420	443	462	431	464	490	511
	LO PR	111	118	128	137	117	124	136	145	121	129	141	150	128	136	148	158	134	142	155	165	138	147	161	171
	MBh	39.2	40.3	43.7	46.9	38.3	39.4	42.7	45.8	37.4	38.5	41.6	44.7	36.5	37.5	40.6	43.6	34.6	35.7	38.6	41.4	32.1	33.0	35.7	38.4
	S/T	0.81	0.73	0.55	0.35	0.84	0.75	0.57	0.37	0.87	0.77	0.59	0.38	0.89	0.80	0.60	0.39	0.93	0.83	0.63	0.40	0.93	0.84	0.63	0.41
	Delta T	23	21	17	12	23	21	17	12	23	21	17	12	23	21	17	12	23	21	17	12	21	20	16	11
1139	KW	2.54	2.60	2.68	2.77	2.74	2.80	2.89	2.99	2.92	2.98	3.08	3.19	3.07	3.14	3.25	3.36	3.21	3.28	3.39	3.51	3.32	3.40	3.51	3.63
	A/MPs	11.6	11.8	12.1	12.5	12.4	12.6	13.0	13.4	13.3	13.6	14.0	14.5	14.1	14.4	14.9	15.4	14.9	15.3	15.7	16.3	15.7	16.1	16.6	17.1
	HI/PR	236	254	268	280	265	285	301	314	301	324	342	357	343	369	390	407	386	415	439	458	427	459	485	506
	LO PR	110	117	127	135	116	123	134	143	120	128	140	149	126	134	147	156	132	141	154	164	137	146	159	169
	MBh	36.2	37.2	40.3	43.3	35.3	36.4	39.4	42.3	34.5	35.5	38.4	41.2	33.6	34.6	37.5	40.2	32.0	32.9	35.6	38.2	29.6	30.5	33.0	35.4
	S/T	0.79	0.70	0.53	0.34	0.81	0.73	0.55	0.35	0.83	0.75	0.56	0.36	0.86	0.77	0.58	0.38	0.89	0.80	0.61	0.39	0.90	0.81	0.61	0.39
	Delta T	23	21	17	12	23	21	18	12	23	21	18	12	23	22	18	12	23	21	17	12	22	20	16	11
	KW	2.48	2.53	2.62	2.70	2.67	2.73	2.82	2.92	2.85	2.91	3.00	3.11	3.00	3.06	3.17	3.27	3.13	3.20	3.30	3.42	3.24	3.31	3.42	3.54
	A/MPs	11.3	11.5	11.9	12.2	12.1	12.3	12.7	13.1	13.0	13.3	13.7	14.1	13.8	14.1	14.5	15.0	14.6	14.9	15.3	15.8	15.3	15.7	16.1	16.7
	HI/PR	229	246	260	271	257	277	292	305	292	314	332	346	333	358	378	394	374	403	425	444	414	445	470	490
LO PR	106	113	123	131	112	119	130	139	117	124	135	144	123	130	142	152	128	137	149	159	133	141	154	164	

\* IDB: Entering Indoor Dry Bulb Temperature

High and low pressures are measured at the liquid and suction access fittings.

NOTE: Shaded area is ACCA (TVA) conditions

# COOLING PERFORMANCE DATA

\*PC1442H41AB/B\*/C\*/D\*

## EXPANDED PERFORMANCE DATA

## EXPANDED PERFORMANCE DATA

## MODEL: \*PC1442H41\*\*

Design Subcooling: 8 ± 2 °F @ the liquid access fitting connection AHRI 95 test conditions. Design Superheat 8 ± 2 °F @ the compressor suction access fitting connection.

IDB*	Airflow	Outdoor Ambient Temperature																													
		65					75					85					95					105					115				
		59	63	67	71	75	59	63	67	71	75	59	63	67	71	75	59	63	67	71	75	59	63	67	71	75	59	63	67	71	75
80	1461	MBh	41.1	42.0	44.8	47.9	40.1	41.0	43.8	46.8	39.2	40.0	42.8	45.7	38.2	39.0	41.7	44.6	36.3	37.1	39.6	42.4	33.6	34.4	36.7	39.2					
		S/T	0.94	0.88	0.71	0.53	0.97	0.91	0.74	0.55	1.00	0.93	0.76	0.57	1.00	0.96	0.78	0.59	1.00	1.00	0.81	0.61	1.00	1.00	0.82	0.61					
		Delta T	24	23	20	16	25	24	20	16	24	25	24	20	16	24	24	21	16	23	23	20	16	21	22	19	15				
		KW	2.58	2.64	2.73	2.82	2.79	2.85	2.94	3.04	2.97	3.03	3.14	3.24	3.13	3.20	3.30	3.42	3.26	3.34	3.45	3.57	3.38	3.46	3.57	3.70					
		AMPS	11.8	12.0	12.3	12.7	12.6	12.8	13.2	13.6	13.5	13.8	14.2	14.7	14.4	14.7	15.1	15.6	15.2	15.5	16.0	16.5	16.0	16.3	16.8	17.4					
	1300	HIPR	241	259	274	285	270	291	307	320	307	331	349	364	350	377	398	415	394	424	448	467	435	468	494	516					
		LO PR	112	119	130	138	118	126	137	146	123	131	142	152	129	137	150	159	135	144	157	167	140	149	162	173					
		MBh	39.9	40.8	43.5	46.5	39.0	39.8	42.5	45.5	38.0	38.9	41.5	44.4	37.1	37.9	40.5	43.3	35.2	36.0	38.5	41.1	32.6	33.4	35.6	38.1					
		S/T	0.89	0.84	0.68	0.51	0.93	0.87	0.71	0.53	0.95	0.89	0.72	0.54	0.98	0.92	0.75	0.56	1.00	0.95	0.78	0.58	1.00	0.96	0.78	0.59					
		Delta T	25	24	21	17	25	24	21	17	26	24	21	17	26	25	21	17	25	24	21	17	23	23	20	16					
1139	KW	2.56	2.62	2.70	2.79	2.77	2.83	2.92	3.02	2.94	3.01	3.11	3.21	3.10	3.17	3.28	3.39	3.23	3.31	3.42	3.54	3.35	3.43	3.54	3.67						
	AMPS	11.7	11.9	12.2	12.6	12.5	12.7	13.1	13.5	13.4	13.7	14.1	14.6	14.2	14.5	15.0	15.5	15.1	15.4	15.8	16.4	15.9	16.2	16.7	17.3						
	HIPR	238	257	271	283	268	288	304	317	304	327	346	361	347	373	394	411	390	420	443	462	431	464	490	511						
	LO PR	111	118	128	137	117	124	136	145	121	129	141	150	128	136	148	158	134	142	155	165	138	147	161	171						
	MBh	36.8	37.6	40.2	43.0	36.0	36.7	39.3	42.0	35.1	35.9	38.3	41.0	34.2	35.0	37.4	40.0	32.5	33.2	35.5	38.0	30.1	30.8	32.9	35.2						
85	1461	S/T	0.86	0.81	0.66	0.49	0.89	0.84	0.68	0.51	0.92	0.86	0.70	0.52	0.94	0.89	0.72	0.54	0.98	0.92	0.75	0.56	0.99	0.93	0.75	0.56					
		Delta T	26	25	21	17	26	25	22	17	26	25	22	17	26	25	22	17	26	25	21	17	24	23	20	16					
		KW	2.50	2.56	2.64	2.72	2.70	2.76	2.85	2.94	2.87	2.93	3.03	3.13	3.02	3.09	3.19	3.30	3.15	3.22	3.33	3.45	3.26	3.34	3.45	3.57					
		AMPS	11.4	11.6	12.0	12.3	12.2	12.4	12.8	13.2	13.1	13.4	13.8	14.2	13.9	14.2	14.6	15.1	14.7	15.0	15.4	16.0	15.5	15.8	16.3	16.8					
		HIPR	231	249	263	274	260	279	295	308	295	318	335	350	336	362	382	398	378	407	430	448	418	450	475	495					
	1300	LO PR	107	114	125	133	113	121	132	140	118	125	137	146	124	132	144	153	130	138	151	160	134	143	156	166					
		MBh	41.8	42.6	44.6	47.6	40.8	41.6	43.6	46.5	39.9	40.6	42.5	45.4	38.9	39.6	41.5	44.3	36.9	37.6	39.4	42.1	34.2	34.9	36.5	39.0					
		S/T	0.98	0.95	0.85	0.69	1.00	0.98	0.89	0.72	1.00	1.00	0.91	0.74	1.00	1.00	0.94	0.76	1.00	1.00	0.97	0.79	1.00	1.00	0.98	0.80					
		Delta T	26	25	24	21	26	26	24	21	25	26	24	21	24	25	24	21	23	24	24	21	22	22	23	20					
		KW	2.61	2.66	2.75	2.84	2.81	2.87	2.97	3.07	2.99	3.06	3.16	3.27	3.15	3.22	3.33	3.45	3.29	3.36	3.48	3.60	3.41	3.49	3.60	3.73					
85	1461	AMPS	11.8	12.1	12.4	12.8	12.7	12.9	13.3	13.8	13.6	13.9	14.3	14.8	14.5	14.8	15.2	15.7	15.3	15.6	16.1	16.7	16.1	16.5	17.0	17.6					
		HIPR	243	262	276	288	273	294	310	324	310	334	353	368	354	380	402	419	398	428	452	471	439	473	499	521					
		LO PR	113	120	131	140	119	127	138	147	124	132	144	153	130	138	151	161	136	145	158	169	141	150	164	175					
		MBh	40.6	41.4	43.3	46.2	39.6	40.4	42.3	45.1	38.7	39.4	41.3	44.1	37.7	38.5	40.3	43.0	35.9	36.6	38.3	40.8	33.2	33.9	35.5	37.8					
		S/T	0.94	0.90	0.82	0.66	0.97	0.94	0.85	0.69	1.00	0.96	0.87	0.70	1.00	0.99	0.89	0.73	1.00	1.00	0.93	0.75	1.00	1.00	0.94	0.76					
	1300	Delta T	27	26	25	22	27	27	25	22	27	27	25	22	27	27	25	22	25	26	25	22	23	24	23	20					
		KW	2.58	2.64	2.73	2.82	2.79	2.85	2.94	3.04	2.97	3.03	3.14	3.24	3.13	3.20	3.30	3.42	3.26	3.34	3.45	3.57	3.38	3.46	3.57	3.70					
		AMPS	11.8	12.0	12.3	12.7	12.6	12.8	13.2	13.6	13.5	13.8	14.2	14.7	14.4	14.7	15.1	15.6	15.2	15.5	16.0	16.5	16.0	16.3	16.8	17.4					
		HIPR	241	259	274	285	270	291	307	320	307	331	349	364	350	377	398	415	394	424	448	467	435	468	494	516					
		LO PR	112	119	130	138	118	126	137	146	123	131	142	152	129	137	150	159	135	144	157	167	140	149	162	173					
1139	MBh	37.5	38.2	40.0	42.7	36.6	37.3	39.1	41.7	35.7	36.4	38.1	40.7	34.8	35.5	37.2	39.7	33.1	33.7	35.3	37.7	30.7	31.3	32.7	34.9						
	S/T	0.90	0.87	0.79	0.64	0.94	0.90	0.81	0.66	0.96	0.93	0.84	0.68	0.99	0.96	0.86	0.70	1.00	0.99	0.90	0.73	1.00	1.00	0.90	0.73						
	Delta T	27	27	25	22	28	27	26	22	28	27	26	22	28	27	26	22	27	27	26	22	25	25	24	21						
	KW	2.52	2.58	2.66	2.75	2.72	2.78	2.87	2.97	2.89	2.96	3.06	3.16	3.05	3.12	3.22	3.33	3.18	3.25	3.36	3.48	3.29	3.37	3.48	3.60						
	AMPS	11.5	11.7	12.0	12.4	12.3	12.5	12.9	13.3	13.2	13.5	13.9	14.3	14.0	14.3	14.7	15.2	14.8	15.1	15.6	16.1	15.6	15.9	16.4	17.0						
1139	HIPR	234	251	265	277	262	282	298	311	298	321	339	353	340	365	386	402	382	411	434	453	422	454	480	500						
	LO PR	108	115	126	134	115	122	133	142	119	127	138	147	125	133	145	155	131	139	152	162	136	144	157	168						

NOTE: Shaded area reflects AHRI rating conditions

IDB*	Airflow	Outdoor Ambient Temperature																													
		65					75					85					95					105					115				
		59	63	67	71	75	59	63	67	71	75	59	63	67	71	75	59	63	67	71	75	59	63	67	71	75	59	63	67	71	75
85	1461	MBh	41.8	42.6	44.6	47.6	40.8	41.6	43.6	46.5	39.9	40.6	42.5	45.4	38.9	39.6	41.5	44.3	36.9	37.6	39.4	42.1	34.2	34.9	36.5	39.0					
		S/T	0.98	0.95	0.85	0.69	1.00	0.98	0.89	0.72	1.00	1.00	0.91	0.74	1.00	1.00	0.94	0.76	1.00	1.00	0.97	0.79	1.00	1.00	0.98	0.80					
		Delta T	26	25	24	21	26	26	24	21	25	26	24	21	24	25	24	21	23	24	24	21	22	22	23	20					
		KW	2.61	2.66	2.75	2.84	2.81	2.87	2.97	3.07	2.99	3.06	3.16	3.27	3.15	3.22	3.33	3.45	3.29	3.36	3.48	3.60	3.41	3.49	3.60	3.73					
		AMPS	11.8	12.1	12.4	12.8	12.7	12.9	13.3	13.8	13.6	13.9	14.3	14.8	14.5	14.8	15.2	15.7	15.3	15.6	16.1	16.7	16.1	16.5	17.0	17.6					
	1300	HIPR	243	262	276	288	273	294	310	324	310	334	353	368	354	380	402	419	398	428	452	471	439	473	499	521					
		LO PR	113	120	131	140	119	127	138	147	124	132	144	153	130	138	151	161	136	145	158	169	141	150	164	175					
		MBh	40.6	41.4	43.3	46.2	39.6	40.4	42.3	45.1	38.7	39.4	41.3	44.1	37.7	38.5	40.3	43.0	35.9	36.6	38.3	40.8	33.2	33.9	35.5	37.8					
		S/T	0.94	0.90	0.82	0.66	0.97	0.94	0.85	0.69	1.00	0.96	0.87	0.70	1.00	0.99	0.89	0.73	1.00	1.00	0.93	0.75									

# COOLING PERFORMANCE DATA

**\*PC1448H41AB/B\*/C\*/D\***

## MODEL: \*PC1448H41\*\* EXPANDED PERFORMANCE DATA COOLING OPERATION

Design Subcooling, 10 ± 2 °F @ the liquid access fitting connection AHRI 95 test conditions. Design Superheat 10 ± 2°F @ the compressor suction access fitting connection.

		Outdoor Ambient Temperature																								
		65				75				85				95				105				115				
IDB*	Airflow	Entering Indoor Wet Bulb Temperature																								
		59	63	67	71	59	63	67	71	59	63	67	71	59	63	67	71	59	63	67	71	59	63	67	71	
70	1800	MBh	45.6	47.2	51.7	-	44.5	46.1	50.5	-	43.4	45.0	49.3	-	42.4	43.9	48.1	-	40.3	41.7	45.7	-	37.3	38.7	42.4	-
		S/T	0.76	0.64	0.44	-	0.79	0.66	0.46	-	0.81	0.68	0.47	-	0.84	0.70	0.48	-	0.87	0.73	0.50	-	0.88	0.73	0.51	-
		Delta T	18	15	12	-	18	16	12	-	18	16	12	-	18	16	12	-	18	15	12	-	17	14	11	-
		KW	2.94	3.01	3.10	-	3.17	3.24	3.34	-	3.37	3.44	3.56	-	3.55	3.63	3.75	-	3.70	3.78	3.91	-	3.83	3.91	4.04	-
		AMPS	12.7	13.0	13.4	-	13.7	14.0	14.4	-	14.7	15.0	15.5	-	15.6	16.0	16.5	-	16.6	16.9	17.4	-	17.5	17.9	18.4	-
		HI PR	236	254	268	-	264	284	300	-	301	324	342	-	342	369	389	-	385	415	438	-	426	458	484	-
	1600	LO PR	110	117	128	-	117	124	135	-	121	129	141	-	127	135	148	-	133	142	155	-	138	147	160	-
		MBh	44.2	45.9	50.2	-	43.2	44.8	49.1	-	42.2	43.7	47.9	-	41.2	42.7	46.7	-	39.1	40.5	44.4	-	36.2	37.5	41.1	-
		S/T	0.73	0.61	0.42	-	0.75	0.63	0.44	-	0.77	0.65	0.45	-	0.80	0.67	0.46	-	0.83	0.69	0.48	-	0.84	0.70	0.48	-
		Delta T	18	16	12	-	19	16	12	-	19	16	12	-	19	16	12	-	19	16	12	-	17	15	11	-
		KW	2.92	2.98	3.08	-	3.14	3.21	3.32	-	3.34	3.42	3.53	-	3.52	3.60	3.71	-	3.67	3.75	3.87	-	3.80	3.88	4.01	-
		AMPS	12.6	12.9	13.3	-	13.6	13.8	14.3	-	14.6	14.9	15.4	-	15.5	15.9	16.3	-	16.4	16.8	17.3	-	17.3	17.7	18.2	-
1400	HI PR	233	251	265	-	262	282	297	-	298	320	338	-	339	365	385	-	381	410	433	-	421	454	479	-	
	LO PR	109	116	127	-	116	123	134	-	120	128	139	-	126	134	146	-	132	141	153	-	137	145	159	-	
	MBh	40.8	42.3	46.4	-	39.9	41.3	45.3	-	38.9	40.4	44.2	-	38.0	39.4	43.1	-	36.1	37.4	41.0	-	33.4	34.6	38.0	-	
	S/T	0.70	0.59	0.41	-	0.73	0.61	0.42	-	0.75	0.62	0.43	-	0.77	0.64	0.45	-	0.80	0.67	0.46	-	0.81	0.67	0.47	-	
	Delta T	19	16	12	-	19	16	13	-	19	16	13	-	19	17	13	-	19	16	12	-	18	15	12	-	
	KW	2.85	2.91	3.00	-	3.07	3.13	3.23	-	3.26	3.33	3.44	-	3.43	3.51	3.62	-	3.57	3.65	3.78	-	3.70	3.78	3.91	-	
75	1800	AMPS	12.3	12.6	13.0	-	13.2	13.5	13.9	-	14.2	14.5	15.0	-	15.1	15.5	15.9	-	16.0	16.4	16.9	-	16.9	17.2	17.8	-
		HI PR	226	243	257	-	254	273	289	-	289	311	328	-	329	354	374	-	370	398	420	-	409	440	465	-
		LO PR	106	113	123	-	112	119	130	-	116	124	135	-	122	130	142	-	128	136	149	-	133	141	154	-
		MBh	46.3	47.7	51.6	55.4	45.3	46.6	50.4	54.1	44.2	45.5	49.2	52.8	43.1	44.4	48.0	51.6	41.0	42.2	45.6	49.0	37.9	39.1	42.3	45.4
		S/T	0.87	0.78	0.59	0.38	0.90	0.80	0.61	0.39	0.92	0.82	0.62	0.40	0.95	0.85	0.64	0.41	0.99	0.88	0.67	0.43	1.00	0.89	0.67	0.43
		Delta T	21	19	15	11	21	19	16	11	21	19	16	11	21	19	16	11	21	19	16	11	19	18	15	10
	1600	KW	2.97	3.03	3.13	3.23	3.20	3.27	3.37	3.48	3.40	3.47	3.59	3.71	3.58	3.66	3.78	3.90	3.73	3.81	3.94	4.07	3.86	3.95	4.08	4.22
		AMPS	12.8	13.1	13.5	14.0	13.8	14.1	14.5	15.0	14.8	15.2	15.6	16.2	15.8	16.1	16.6	17.2	16.7	17.1	17.6	18.2	17.6	18.0	18.6	19.2
		HI PR	238	256	270	282	267	287	303	317	304	327	345	360	346	372	393	410	389	419	442	461	430	463	489	510
		LO PR	112	119	130	138	118	125	137	146	122	130	142	152	129	137	149	159	135	143	157	167	139	148	162	173
		MBh	45.0	46.3	50.1	53.8	43.9	45.2	49.0	52.6	42.9	44.2	47.8	51.3	41.9	43.1	46.6	50.1	39.8	40.9	44.3	47.6	36.8	37.9	41.0	44.0
		S/T	0.83	0.74	0.56	0.36	0.86	0.77	0.58	0.37	0.88	0.79	0.59	0.38	0.91	0.81	0.61	0.40	0.94	0.84	0.64	0.41	0.95	0.85	0.64	0.41
1400	Delta T	21	20	16	11	22	20	16	11	22	20	16	11	22	20	16	11	22	20	16	11	20	18	15	10	
	KW	2.94	3.01	3.10	3.20	3.17	3.24	3.34	3.45	3.37	3.44	3.56	3.68	3.55	3.63	3.75	3.87	3.70	3.78	3.91	4.04	3.83	3.91	4.05	4.18	
	AMPS	12.7	13.0	13.4	13.8	13.7	14.0	14.4	14.9	14.7	15.0	15.5	16.0	15.6	16.0	16.5	17.0	16.6	16.9	17.4	18.1	17.5	17.9	18.4	19.1	
	HI PR	236	254	268	279	264	285	300	313	301	324	342	356	343	369	389	406	385	415	438	457	426	458	484	505	
	LO PR	110	118	128	137	117	124	136	144	121	129	141	150	127	136	148	158	134	142	155	165	138	147	160	171	
	MBh	41.5	42.8	46.3	49.7	40.6	41.8	45.2	48.5	39.6	40.8	44.1	47.4	38.6	39.8	43.0	46.2	36.7	37.8	40.9	43.9	34.0	35.0	37.9	40.7	
1400	S/T	0.80	0.71	0.54	0.35	0.83	0.74	0.56	0.36	0.85	0.76	0.57	0.37	0.87	0.78	0.59	0.38	0.91	0.81	0.61	0.40	0.92	0.82	0.62	0.40	
	Delta T	22	20	16	11	22	20	17	11	22	20	17	11	22	20	17	11	22	20	17	11	20	19	15	11	
	KW	2.87	2.93	3.03	3.12	3.09	3.16	3.26	3.37	3.29	3.36	3.47	3.58	3.46	3.54	3.65	3.77	3.61	3.69	3.81	3.94	3.73	3.81	3.94	4.08	
	AMPS	12.4	12.7	13.1	13.5	13.3	13.6	14.0	14.5	14.4	14.7	15.1	15.6	15.2	15.6	16.1	16.6	16.1	16.5	17.0	17.6	17.0	17.4	17.9	18.6	
	HI PR	229	246	260	271	256	276	291	304	292	314	331	346	332	358	378	394	374	402	425	443	413	444	469	489	
	LO PR	107	114	124	133	113	120	131	140	118	125	137	146	124	131	144	153	129	138	150	160	134	143	156	166	

\* IDB: Entering Indoor Dry Bulb Temperature NOTE: Shaded area is ACCA (TVA) conditions

High and low pressures are measured at the liquid and suction access fittings.



**MODEL: \*PC1448H41\*\***

**EXPANDED PERFORMANCE DATA**

**COOLING OPERATION**

Design Subcooling, 10 ± 2 °F @ the liquid access fitting connection A HRI 95 test conditions. Design Superheat 10 ± 2°F @ the compressor suction access fitting connection.

IDB*	Airflow	Outdoor Ambient Temperature																													
		65					75					85					95					105					115				
		59	63	67	71	75	59	63	67	71	75	59	63	67	71	75	59	63	67	71	75	59	63	67	71	75	59	63	67	71	75
80	1800	MBh	47.2	48.2	51.5	55.0	46.1	47.1	50.3	53.8	45.0	46.0	49.1	52.5	43.9	44.8	47.9	51.2	41.7	42.6	45.5	48.6	38.6	39.5	42.1	45.1					
		S/T	0.95	0.89	0.73	0.54	1.00	0.92	0.75	0.56	1.00	0.95	0.77	0.58	1.00	1.00	0.80	0.60	1.00	1.00	0.83	0.62	1.00	1.00	0.83	0.62					
	Delta T	23	22	19	15	24	22	19	15	23	22	19	15	22	23	23	19	16	21	22	22	19	15	20	20	18	14				
	KW	2.99	3.05	3.15	3.25	3.22	3.29	3.40	3.51	3.43	3.50	3.62	3.74	3.61	3.69	3.81	3.94	3.76	3.76	3.85	3.97	4.11	3.89	3.98	4.11	4.26					
	A/MPs	13.0	13.2	13.6	14.1	13.9	14.2	14.6	15.1	15.0	15.3	15.8	16.3	15.9	16.3	16.8	17.3	16.8	17.2	17.7	18.4	17.8	18.2	18.7	19.4						
	HI PR	240	259	273	285	270	290	307	320	307	330	349	364	349	376	397	414	393	423	447	466	434	467	494	515						
	LO PR	113	120	131	139	119	127	138	147	124	132	144	153	130	138	151	161	136	145	158	168	141	150	164	174						
	MBh	45.8	46.8	50.0	53.4	44.7	45.7	48.8	52.2	43.7	44.6	47.7	51.0	42.6	43.5	46.5	49.7	40.5	41.3	44.2	47.2	37.5	38.3	40.9	43.7						
	S/T	0.91	0.85	0.69	0.52	0.94	0.88	0.72	0.54	0.96	0.90	0.74	0.55	0.99	0.93	0.76	0.57	1.00	0.97	0.79	0.59	1.00	0.98	0.79	0.59						
	Delta T	24	23	20	16	24	23	20	16	24	23	20	16	24	24	23	20	16	23	23	20	16	22	21	19	15					
KW	2.97	3.03	3.13	3.23	3.20	3.27	3.37	3.48	3.40	3.47	3.59	3.71	3.58	3.66	3.78	3.91	3.73	3.81	3.94	4.07	3.86	3.95	4.08	4.22							
A/MPs	12.9	13.1	13.5	14.0	13.8	14.1	14.5	15.0	14.8	15.2	15.6	16.2	15.8	16.1	16.6	17.2	16.7	17.1	17.6	18.2	17.6	18.0	18.6	19.2							
HI PR	238	256	270	282	267	287	304	317	304	327	345	360	346	372	393	410	389	419	442	461	430	463	489	510							
LO PR	112	119	130	138	118	125	137	146	122	130	142	152	129	137	149	159	135	143	157	167	139	148	162	173							
MBh	42.3	43.2	46.1	49.3	41.3	42.2	45.1	48.2	40.3	41.2	44.0	47.0	39.3	40.2	42.9	45.9	37.3	38.2	40.8	43.6	34.6	35.4	37.8	40.4							
S/T	0.87	0.82	0.67	0.50	0.91	0.85	0.69	0.52	0.93	0.87	0.71	0.53	0.96	0.90	0.73	0.55	1.00	0.93	0.76	0.57	1.00	0.94	0.77	0.57							
Delta T	24	23	20	16	25	24	20	16	25	24	20	16	25	24	21	16	24	23	20	16	23	22	19	15							
KW	2.90	2.96	3.05	3.15	3.12	3.19	3.29	3.40	3.31	3.39	3.50	3.61	3.49	3.57	3.68	3.81	3.64	3.72	3.84	3.97	3.76	3.85	3.98	4.11							
A/MPs	12.5	12.8	13.2	13.6	13.4	13.7	14.1	14.6	14.5	14.8	15.2	15.8	15.4	15.7	16.2	16.8	16.3	16.6	17.1	17.7	17.2	17.5	18.1	18.7							
HI PR	231	248	262	274	259	279	294	307	295	317	335	349	336	361	381	398	378	406	429	447	417	449	474	494							
LO PR	108	115	126	134	114	122	133	141	119	126	138	147	125	133	145	154	131	139	152	162	135	144	157	167							

NOTE: Shaded area reflects A HRI rating conditions

IDB*	Airflow	Outdoor Ambient Temperature																													
		65					75					85					95					105					115				
		59	63	67	71	75	59	63	67	71	75	59	63	67	71	75	59	63	67	71	75	59	63	67	71	75	59	63	67	71	75
85	1800	MBh	48.0	48.9	51.2	54.7	46.9	47.8	50.0	53.4	45.8	46.6	48.8	52.1	44.6	45.5	47.7	50.8	42.4	43.2	45.3	48.3	39.3	40.0	41.9	44.7					
		S/T	1.00	0.96	0.87	0.70	1.00	1.00	0.90	0.73	1.00	1.00	0.92	0.75	1.00	1.00	0.95	0.77	1.00	1.00	0.99	0.80	1.00	1.00	0.95	0.81					
	Delta T	24	24	23	20	24	24	23	20	23	24	23	20	23	23	23	20	22	22	23	20	20	20	20	21	18					
	KW	3.01	3.08	3.18	3.28	3.25	3.32	3.43	3.54	3.46	3.53	3.65	3.77	3.64	3.72	3.84	3.97	3.79	3.88	4.01	4.14	3.93	4.02	4.15	4.29						
	A/MPs	13.1	13.3	13.7	14.2	14.0	14.3	14.7	15.2	15.1	15.4	15.9	16.4	16.0	16.4	16.9	17.5	17.0	17.4	17.9	18.5	17.9	18.3	18.9	19.6						
	HI PR	243	261	276	288	272	293	310	323	310	333	352	367	353	380	401	418	397	427	451	471	439	472	499	520						
	LO PR	114	121	132	141	120	128	140	149	125	133	145	155	131	140	152	162	138	146	160	170	142	151	165	176						
	MBh	46.6	47.5	49.7	53.1	45.5	46.4	48.6	51.8	44.4	45.3	47.4	50.6	43.3	44.2	46.3	49.4	41.2	42.0	44.0	46.9	38.1	38.9	40.7	43.4						
	S/T	0.95	0.92	0.83	0.67	0.99	0.95	0.86	0.70	1.00	0.97	0.88	0.71	1.00	1.00	0.91	0.74	1.00	1.00	0.94	0.76	1.00	1.00	0.95	0.77						
	Delta T	25	25	24	20	26	25	24	21	26	25	24	21	25	25	24	21	24	24	24	21	22	22	22	19						
KW	2.99	3.05	3.15	3.25	3.22	3.29	3.40	3.51	3.43	3.50	3.62	3.74	3.61	3.69	3.81	3.94	3.76	3.85	3.97	4.11	3.89	3.98	4.11	4.26							
A/MPs	13.0	13.2	13.6	14.1	13.9	14.2	14.6	15.1	15.0	15.3	15.8	16.3	15.9	16.3	16.8	17.3	16.8	17.2	17.7	18.4	17.8	18.2	18.7	19.4							
HI PR	240	259	273	285	270	290	307	320	307	330	349	364	349	376	397	414	393	423	447	466	434	467	494	515							
LO PR	113	120	131	139	119	127	138	147	124	132	144	153	130	138	151	161	136	145	158	168	141	150	164	174							
MBh	43.0	43.8	45.9	49.0	42.0	42.8	44.8	47.8	41.0	41.8	43.8	46.7	40.0	40.8	42.7	45.6	38.0	38.7	40.6	43.3	35.2	35.9	37.6	40.1							
S/T	0.92	0.88	0.80	0.65	0.95	0.92	0.83	0.67	0.97	0.94	0.85	0.69	1.00	0.97	0.88	0.71	1.00	1.00	0.91	0.74	1.00	1.00	0.92	0.74							
Delta T	26	25	24	21	26	26	24	21	26	26	24	21	26	26	25	21	25	25	24	21	23	24	23	20							
KW	2.92	2.98	3.07	3.17	3.14	3.21	3.31	3.42	3.34	3.42	3.53	3.64	3.52	3.60	3.71	3.84	3.67	3.75	3.87	4.00	3.79	3.88	4.01	4.15							
A/MPs	12.6	12.9	13.3	13.7	13.5	13.8	14.2	14.7	14.6	14.9	15.4	15.9	15.5	15.8	16.3	16.9	16.4	16.8	17.3	17.9	17.3	17.7	18.2	18.9							
HI PR	233	251	265	276	262	282	297	310	298	320	338	353	339	365	385	402	381	410	433	452	421	453	479	499							
LO PR	109	116	127	135	115	123	134	143	120	128	139	148	126	134	146	156	132	141	153	163	137	145	159	169							

\* NOTE: Shaded areas is A HRI Rating Conditions IDB: Entering Indoor Dry Bulb Temperature KW = Total system power  
High and low pressures are measured at the liquid and suction access fittings. AMPS: Unit amps (comp. + evaporator + condenser fan motors)

# COOLING PERFORMANCE DATA

**\*PC1460H41B\*/C\*/D\***

**MODEL: \*PC1460H41\*\***

## EXPANDED PERFORMANCE DATA

**COOLING OPERATION**

Design Subcooling, 6 ± 2 °F @ the liquid access fitting connection AHRI 95 test conditions. Design Superheat 9 ± 2°F @ the compressor suction access fitting connection.

IDB*	Airflow	Outdoor Ambient Temperature																													
		65					75					85					95					105					115				
		59	63	67	71	75	59	63	67	71	75	59	63	67	71	75	59	63	67	71	75	59	63	67	71	75	59	63	67	71	75
70	1800	MBh	56.3	58.4	64.0	-	55.0	57.0	62.5	-	53.7	55.7	61.0	-	52.4	54.3	59.5	-	49.8	51.6	56.5	-	46.1	47.8	52.4	-	46.1	47.8	52.4	-	
		S/T	0.71	0.60	0.41	-	0.74	0.62	0.43	-	0.76	0.63	0.44	-	0.78	0.65	0.45	-	0.81	0.68	0.47	-	0.82	0.69	0.47	-	0.82	0.69	0.47	-	
		Delta T	21	18	14	-	21	18	14	-	21	18	14	-	21	18	14	-	21	18	14	-	19	17	13	-	19	17	13	-	
		KW	3.70	3.78	3.91	-	4.00	4.09	4.23	-	4.26	4.36	4.51	-	4.49	4.60	4.75	-	4.69	4.80	4.96	-	4.86	4.97	5.14	-	4.86	4.97	5.14	-	
		AMPS	15.7	16.0	16.5	-	16.9	17.2	17.8	-	18.2	18.6	19.2	-	19.4	19.9	20.5	-	20.6	21.1	21.7	-	21.7	22.3	23.0	-	21.7	22.3	23.0	-	
		HIPR	238	256	271	-	267	288	304	-	304	327	345	-	346	373	393	-	390	419	443	-	430	463	489	-	430	463	489	-	
	1600	LO PR	108	115	125	-	114	121	132	-	118	126	137	-	124	132	144	-	130	139	151	-	135	143	156	-	135	143	156	-	
		MBh	54.7	56.7	62.1	-	53.4	55.4	60.7	-	52.2	54.1	59.2	-	50.9	52.7	57.8	-	48.3	50.1	54.9	-	44.8	46.4	50.9	-	44.8	46.4	50.9	-	
		S/T	0.68	0.57	0.39	-	0.71	0.59	0.41	-	0.72	0.60	0.42	-	0.75	0.62	0.43	-	0.78	0.65	0.45	-	0.78	0.65	0.45	-	0.78	0.65	0.45	-	
		Delta T	21	19	14	-	22	19	14	-	22	19	14	-	22	19	14	-	22	19	14	-	20	17	13	-	20	17	13	-	
		KW	3.67	3.75	3.88	-	3.97	4.06	4.19	-	4.23	4.32	4.47	-	4.46	4.56	4.71	-	4.65	4.76	4.92	-	4.82	4.93	5.10	-	4.82	4.93	5.10	-	
		AMPS	15.6	15.9	16.4	-	16.7	17.1	17.6	-	18.1	18.5	19.1	-	19.2	19.7	20.3	-	20.4	20.9	21.5	-	21.6	22.1	22.8	-	21.6	22.1	22.8	-	
1400	HIPR	236	254	268	-	265	285	301	-	301	324	342	-	343	369	390	-	386	415	438	-	426	459	484	-	426	459	484	-		
	LO PR	107	114	124	-	113	120	131	-	117	125	136	-	123	131	143	-	129	137	150	-	133	142	155	-	133	142	155	-		
	MBh	50.5	52.3	57.3	-	49.3	51.1	56.0	-	48.1	49.9	54.7	-	47.0	48.7	53.3	-	44.6	46.2	50.7	-	41.3	42.8	46.9	-	41.3	42.8	46.9	-		
	S/T	0.66	0.55	0.38	-	0.68	0.57	0.39	-	0.70	0.58	0.40	-	0.72	0.60	0.42	-	0.75	0.62	0.43	-	0.75	0.63	0.44	-	0.75	0.63	0.44	-		
	Delta T	22	19	14	-	22	19	14	-	22	19	15	-	22	19	15	-	22	19	14	-	20	18	13	-	20	18	13	-		
	KW	3.58	3.66	3.78	-	3.87	3.95	4.08	-	4.12	4.21	4.35	-	4.34	4.44	4.59	-	4.53	4.63	4.79	-	4.69	4.80	4.97	-	4.69	4.80	4.97	-		
75	1800	AMPS	15.2	15.5	16.0	-	16.3	16.7	17.2	-	17.6	18.0	18.6	-	18.7	19.2	19.8	-	19.9	20.3	21.0	-	21.0	21.5	22.2	-	21.0	21.5	22.2	-	
		HIPR	229	246	260	-	257	276	292	-	292	314	332	-	333	358	378	-	374	403	425	-	413	445	470	-	413	445	470	-	
		LO PR	103	110	120	-	109	116	127	-	114	121	132	-	119	127	139	-	125	133	145	-	129	138	150	-	129	138	150	-	
		MBh	57.3	59.0	63.9	68.5	56.0	57.6	62.4	66.9	54.6	56.3	60.9	65.3	53.3	54.9	59.4	63.8	50.6	52.1	56.4	60.6	46.9	48.3	52.3	56.1	46.9	48.3	52.3	56.1	
		S/T	0.81	0.73	0.55	0.35	0.84	0.75	0.57	0.37	0.86	0.77	0.58	0.38	0.89	0.80	0.60	0.39	0.92	0.83	0.63	0.40	0.93	0.83	0.63	0.41	0.93	0.83	0.63	0.41	
		Delta T	24	22	18	12	24	22	18	13	24	22	18	13	24	22	18	13	24	22	18	12	22	21	17	12	22	21	17	12	
	1600	KW	3.73	3.82	3.94	4.07	4.03	4.12	4.26	4.41	4.30	4.40	4.55	4.70	4.53	4.64	4.79	4.96	4.73	4.84	5.01	5.18	4.90	5.02	5.19	5.37	4.90	5.02	5.19	5.37	
		AMPS	15.8	16.2	16.7	17.2	17.0	17.4	17.9	18.6	18.4	18.8	19.4	20.1	19.6	20.0	20.7	21.4	20.8	21.3	21.9	22.7	21.9	22.5	23.2	24.0	21.9	22.5	23.2	24.0	
		HIPR	241	259	273	285	270	291	307	320	307	330	349	364	350	376	397	415	393	423	447	466	435	468	494	515	435	468	494	515	
		LO PR	109	116	126	135	115	122	134	142	120	127	139	148	126	134	146	155	132	140	153	163	136	145	158	168	136	145	158	168	
		MBh	55.6	57.3	62.0	66.5	54.3	55.9	60.6	65.0	53.0	54.6	59.1	63.4	51.8	53.3	57.7	61.9	49.2	50.6	54.8	58.8	45.5	46.9	50.8	54.5	45.5	46.9	50.8	54.5	
		S/T	0.77	0.69	0.52	0.34	0.80	0.72	0.54	0.35	0.82	0.74	0.56	0.36	0.85	0.76	0.58	0.37	0.88	0.79	0.60	0.38	0.89	0.80	0.60	0.39	0.89	0.80	0.60	0.39	
1400	Delta T	25	23	19	13	25	23	19	13	25	23	19	13	25	23	19	13	25	23	19	13	23	21	18	12	23	21	18	12		
	KW	3.70	3.79	3.91	4.04	4.00	4.09	4.23	4.37	4.26	4.36	4.51	4.66	4.49	4.60	4.75	4.92	4.69	4.80	4.96	5.14	4.86	4.97	5.14	5.32	4.86	4.97	5.14	5.32		
	AMPS	15.7	16.0	16.5	17.1	16.9	17.3	17.8	18.4	18.2	18.6	19.2	19.9	19.4	19.9	20.5	21.2	20.6	21.1	21.7	22.5	21.7	22.3	23.0	23.8	21.7	22.3	23.0	23.8		
	HIPR	238	256	271	282	267	288	304	317	304	327	346	360	346	373	394	410	390	419	443	462	430	463	489	510	430	463	489	510		
	LO PR	108	115	125	133	114	121	132	141	118	126	137	146	124	132	144	154	130	139	151	161	135	143	157	167	135	143	157	167		
	MBh	51.3	52.9	57.2	61.4	50.2	51.6	55.9	60.0	49.0	50.4	54.6	58.6	47.8	49.2	53.2	57.1	45.4	46.7	50.6	54.3	42.0	43.3	46.8	50.3	42.0	43.3	46.8	50.3		
1400	S/T	0.75	0.67	0.51	0.33	0.77	0.69	0.52	0.34	0.79	0.71	0.54	0.35	0.82	0.73	0.55	0.36	0.85	0.76	0.58	0.37	0.86	0.77	0.58	0.37	0.86	0.77	0.58	0.37		
	Delta T	25	23	19	13	25	23	19	13	26	24	19	13	26	24	19	13	25	23	19	13	24	22	18	12	24	22	18	12		
	KW	3.61	3.69	3.81	3.94	3.90	3.99	4.12	4.26	4.15	4.25	4.39	4.54	4.38	4.48	4.63	4.79	4.57	4.67	4.83	5.00	4.73	4.84	5.01	5.18	4.73	4.84	5.01	5.18		
	AMPS	15.3	15.6	16.1	16.7	16.4	16.8	17.3	17.9	17.8	18.2	18.7	19.4	18.9	19.3	19.9	20.7	20.0	20.5	21.2	21.9	21.2	21.7	22.4	23.2	21.2	21.7	22.4	23.2		
	HIPR	231	249	263	274	259	279	295	307	295	317	335	350	336	361	382	398	378	407	429	448	418	449	474	495	418	449	474	495		
	LO PR	105	111	121	129	110	118	128	137	115	122	133	142	121	128	140	149	126	134	147	156	131	139	152	162	131	139	152	162		

\*IDB: Entering Indoor Dry Bulb Temperature

High and low pressures are measured at the liquid and suction access fittings.

NOTE: Shaded area is ACCA (TVA) conditions

**MODEL: \*PC1460H41\*\***

**EXPANDED PERFORMANCE DATA**

**COOLING OPERATION**

Design Subcooling, 6 ± 2 °F @ the liquid access fitting connection AHRI 95 test conditions. Design Superheat 9 ± 2°F @ the compressor suction access fitting connection.

IDB* Airflow	Outdoor Ambient Temperature																													
	65					75					85					95					105					115				
	59	63	67	71	75	59	63	67	71	75	59	63	67	71	75	59	63	67	71	75	59	63	67	71	75	59	63	67	71	75
1800	MBh	58.3	59.6	63.7	68.1	57.0	58.2	62.2	66.5	55.6	56.8	60.7	64.9	54.3	55.4	59.2	63.3	51.5	52.7	56.3	60.1	47.7	48.8	52.1	55.7					
	S/T	0.89	0.84	0.68	0.51	0.92	0.87	0.70	0.53	0.95	0.89	0.72	0.54	1.00	0.92	0.75	0.56	1.00	0.95	0.77	0.58	1.00	0.96	0.78	0.58					
	Delta T	27	25	22	18	27	26	22	18	27	26	22	18	28	26	23	18	26	26	22	18	24	24	21	17					
	KW	3.77	3.85	3.98	4.11	4.07	4.16	4.30	4.45	4.34	4.43	4.58	4.74	4.57	4.68	4.84	5.00	4.77	4.88	5.05	5.23	4.95	5.06	5.24	5.42					
	AMPS	16.0	16.3	16.8	17.4	17.2	17.5	18.1	18.7	18.5	19.0	19.6	20.3	19.8	20.2	20.8	21.6	21.0	21.4	22.1	22.9	22.1	22.7	23.4	24.2					
	HI PR	243	262	276	288	273	294	310	323	310	334	352	368	353	380	401	419	397	428	452	471	439	473	499	520					
	LO PR	110	117	128	136	116	124	135	144	121	128	140	149	127	135	147	157	133	141	154	164	137	146	160	170					
	MBh	56.6	57.9	61.8	66.1	55.3	56.5	60.4	64.5	54.0	55.2	58.9	63.0	52.7	53.8	57.5	61.5	50.0	51.1	54.6	58.4	46.3	47.4	50.6	54.1					
	S/T	0.85	0.80	0.65	0.48	0.88	0.83	0.67	0.50	0.90	0.85	0.69	0.52	0.93	0.87	0.71	0.53	0.97	0.91	0.74	0.55	0.98	0.91	0.74	0.56					
	Delta T	28	26	23	18	28	27	23	19	28	27	23	19	28	27	24	19	28	27	23	19	26	25	22	17					
KW	3.73	3.82	3.94	4.08	4.03	4.13	4.26	4.41	4.30	4.40	4.55	4.70	4.53	4.64	4.80	4.96	4.73	4.84	5.01	5.18	4.90	5.02	5.19	5.37						
AMPS	15.8	16.2	16.7	17.2	17.0	17.4	17.9	18.6	18.4	18.8	19.4	20.1	19.6	20.0	20.7	21.4	20.8	21.3	21.9	22.7	21.9	22.5	23.2	24.0						
HI PR	241	259	273	285	270	291	307	320	307	331	349	364	350	376	398	415	394	423	447	466	435	468	494	515						
LO PR	109	116	126	135	115	122	134	142	120	127	139	148	126	134	146	155	132	140	153	163	136	145	158	168						
MBh	52.3	53.4	57.1	61.0	51.0	52.2	55.7	59.6	49.8	50.9	54.4	58.2	48.6	49.7	53.1	56.7	46.2	47.2	50.4	53.9	42.8	43.7	46.7	49.9						
S/T	0.82	0.77	0.63	0.47	0.85	0.80	0.65	0.48	0.87	0.82	0.66	0.50	0.90	0.84	0.69	0.51	0.93	0.87	0.71	0.53	0.94	0.88	0.72	0.54						
Delta T	28	27	23	19	28	27	24	19	28	27	24	19	28	27	24	19	28	27	24	19	26	25	22	18						
KW	3.64	3.72	3.84	3.97	3.93	4.02	4.15	4.29	4.19	4.28	4.43	4.58	4.42	4.52	4.67	4.83	4.61	4.71	4.88	5.05	4.78	4.89	5.05	5.23						
AMPS	15.4	15.8	16.2	16.8	16.6	17.0	17.5	18.1	17.9	18.3	18.9	19.6	19.1	19.5	20.1	20.8	20.2	20.7	21.3	22.1	21.4	21.9	22.6	23.4						
HI PR	233	251	265	277	262	282	298	310	298	321	339	353	339	365	386	402	382	411	434	452	422	454	479	500						
LO PR	106	112	123	131	112	119	130	138	116	123	135	143	122	130	141	151	128	136	148	158	132	140	153	163						

NOTE: Shaded area reflects AHRI rating conditions

IDB* Airflow	Outdoor Ambient Temperature																													
	65					75					85					95					105					115				
	59	63	67	71	75	59	63	67	71	75	59	63	67	71	75	59	63	67	71	75	59	63	67	71	75	59	63	67	71	75
1800	MBh	59.3	60.5	63.3	67.6	58.0	59.1	61.9	66.0	56.6	57.7	60.4	64.4	55.2	56.3	58.9	62.9	52.4	53.5	56.0	59.7	48.6	49.5	51.9	55.3					
	S/T	0.93	0.90	0.81	0.66	0.97	0.93	0.84	0.68	0.99	0.96	0.86	0.70	1.00	0.99	0.89	0.72	1.00	1.00	0.93	0.75	1.00	1.00	0.93	0.76					
	Delta T	28	28	26	23	29	28	27	23	29	28	27	23	28	28	27	23	27	27	26	23	25	25	25	21					
	KW	3.80	3.88	4.01	4.14	4.10	4.20	4.34	4.48	4.37	4.47	4.62	4.78	4.61	4.72	4.88	5.05	4.81	4.93	5.09	5.27	4.99	5.10	5.28	5.47					
	AMPS	16.1	16.5	17.0	17.5	17.3	17.7	18.2	18.9	18.7	19.1	19.7	20.4	19.9	20.4	21.0	21.8	21.1	21.6	22.3	23.1	22.3	22.9	23.6	24.5					
	HI PR	245	264	279	291	275	296	313	326	313	337	356	371	357	384	405	423	401	432	456	476	444	477	504	526					
	LO PR	111	118	129	137	117	125	136	145	122	130	142	151	128	136	149	158	134	143	156	166	139	148	161	172					
	MBh	57.6	58.7	61.5	65.6	56.3	57.4	60.1	64.1	54.9	56.0	58.6	62.6	53.6	54.6	57.2	61.0	50.9	51.9	54.4	58.0	47.2	48.1	50.3	53.7					
	S/T	0.89	0.86	0.78	0.63	0.92	0.89	0.80	0.65	0.95	0.91	0.82	0.67	0.98	0.94	0.85	0.69	1.00	0.98	0.88	0.72	1.00	0.99	0.89	0.72					
	Delta T	29	29	27	24	30	29	28	24	30	29	28	24	30	30	30	28	24	29	29	28	24	27	27	26	22				
KW	3.77	3.85	3.98	4.11	4.07	4.16	4.30	4.45	4.34	4.43	4.58	4.74	4.57	4.68	4.84	5.00	4.77	4.88	5.05	5.23	4.95	5.06	5.24	5.42						
AMPS	16.0	16.3	16.8	17.4	17.2	17.5	18.1	18.7	18.5	19.0	19.6	20.3	19.8	20.2	20.8	21.6	21.0	21.4	22.1	22.9	22.1	22.7	23.4	24.2						
HI PR	243	262	276	288	273	294	310	323	310	334	352	368	353	380	401	419	397	428	452	471	439	473	499	520						
LO PR	110	117	128	136	116	124	135	144	121	128	140	149	127	135	147	157	133	141	154	164	137	146	160	170						
MBh	53.2	54.2	56.8	60.6	51.9	52.9	55.4	59.2	50.7	51.7	54.1	57.7	49.5	50.4	52.8	56.3	47.0	47.9	50.2	53.5	43.5	44.4	46.5	49.6						
S/T	0.86	0.83	0.75	0.61	0.89	0.86	0.78	0.63	0.91	0.88	0.79	0.64	0.94	0.91	0.82	0.67	0.98	0.94	0.85	0.69	0.99	0.95	0.86	0.70						
Delta T	30	30	28	24	30	30	28	24	30	30	30	28	24	31	30	28	25	30	30	28	24	28	28	26	23					
KW	3.67	3.75	3.88	4.01	3.97	4.05	4.19	4.33	4.23	4.32	4.47	4.62	4.45	4.56	4.71	4.87	4.65	4.76	4.92	5.09	4.82	4.93	5.10	5.28						
AMPS	15.6	15.9	16.4	17.0	16.7	17.1	17.6	18.2	18.1	18.5	19.1	19.7	19.2	19.7	20.3	21.0	20.4	20.9	21.5	22.3	21.5	22.1	22.8	23.6						
HI PR	236	254	268	279	265	285	301	314	301	324	342	357	343	369	389	406	386	415	438	457	426	458	484	505						
LO PR	107	113	124	132	113	120	131	139	117	125	136	145	123	131	143	152	129	137	150	159	133	142	155	165						

\* NOTE: Shaded areas is AHRI Rating Conditions

IDB: Entering Indoor Dry Bulb Temperature

KW = Total system power

High and low pressures are measured at the liquid and suction access fittings.

AMPS: Unit amps (comp. + evaporator + condenser fan motors)

**COOLING PERFORMANCE DATA**

**\*PC1460H41B\*/C\*/D\***



# COOLING PERFORMANCE DATA

## PERFORMANCE TEST

All data based upon listed indoor dry bulb temperature. .00 inches external static pressure on coil of outdoor section. Indoor air cubic feet per minute (CFM) as listed in the Performance Data Sheets:

If conditions vary from this, results will change as follows:

1. As indoor dry bulb temperatures increase, a slight increase will occur in indoor air temperature drop (Delta T). Low and high side pressures and power will not change.
2. As indoor CFM decreases, a slight increase will occur in indoor temperature drop (Delta T). A slight decrease will occur in low and high side pressures and power.

A properly operating unit should be within plus or minus **3 degrees** of the typical (**Delta T**) value shown.

A properly operating unit should be within plus or minus **7 PSIG** of the **HI PR** shown.

A properly operating unit should be within plus or minus **3 PSIG** of the **LO PR** shown.

A properly operating unit should be within plus or minus **3 Amps** of the typical value shown.

# WIRING DIAGRAMS

# \*PC14[24-48]H41AB/B\*/C\*/D\*

**WARNING**  
 HIGH VOLTAGE!  
 DISCONNECT ALL POWER BEFORE SERVICING OR INSTALLING THIS UNIT. MULTIPLE POWER SOURCES MAY BE PRESENT. FAILURE TO DO SO MAY CAUSE PROPERTY DAMAGE, PERSONAL INJURY OR DEATH.

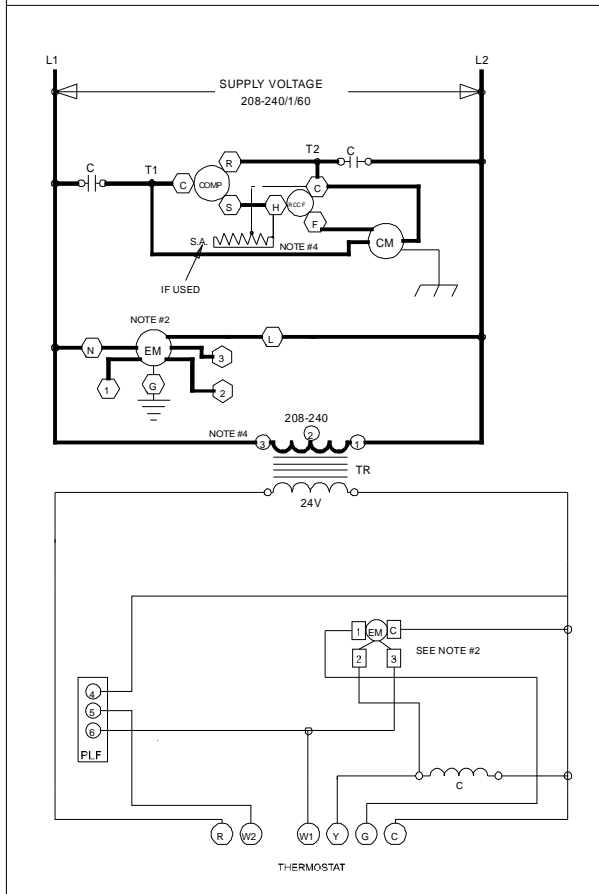
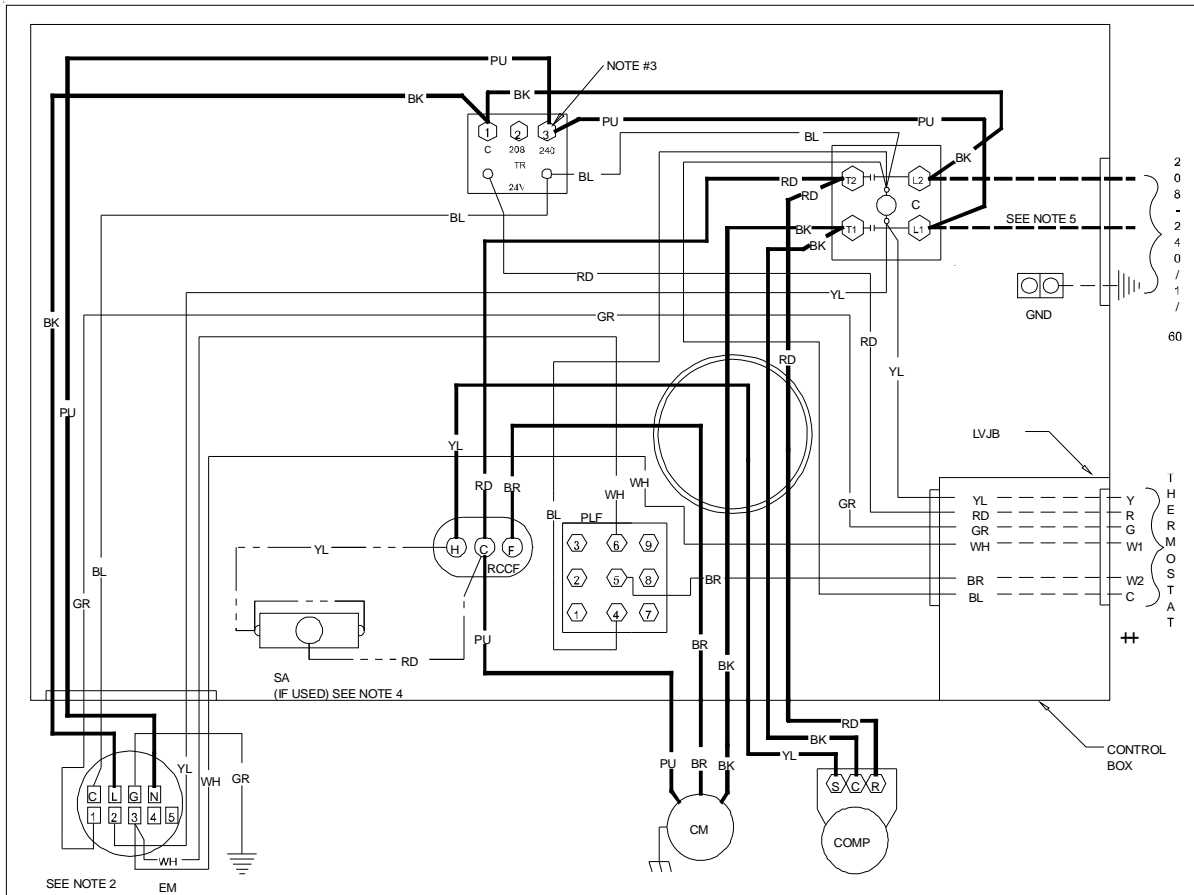

COMPONENT LEGEND		FACTORY WIRING	
C	CONTACTOR	—	LINE VOLTAGE
CM	CONDENSER MOTOR	—	LOW VOLTAGE
COMP	COMPRESSOR	—	OPTIONAL HIGH VOLTAGE
EM	EVAPORATOR MOTOR	—	FIELD WIRING
GND	EQUIPMENT GROUND	---	HIGH VOLTAGE
LVJB	LOW VOLTAGE JUNCTION BOX	---	LOW VOLTAGE
PLF	FEMALE PLUG / CONNECTOR		
RCCF	RUN CAPACITOR FOR COMPRESSOR AND FAN		
SA	START ASSIST		
TR	TRANSFORMER		

WIRE CODE	
BK	BLACK
BL	BLUE
BR	BROWN
GR	GREEN
OR	ORANGE
PU	PURPLE
RD	RED
WH	WHITE
YL	YELLOW

- NOTES:
- REPLACEMENT WIRE MUST BE SAME SIZE AND TYPE INSULATION AS ORIGINAL (AT LEAST 105°C) USE COPPER CONDUCTOR ONLY.
  - TO CHANGE EVAPORATOR MOTOR SPEED MOVE WHITE AND YELLOW LEADS FROM EM "2" AND "3" TO "4" AND "5". IF BOTH LEADS ARE ENERGIZED, THE HIGHER SPEED SETTING IS USED.
  - FOR 208 VOLT TRANSFORMER OPERATION MOVE PURPLE WIRES FROM TERMINAL 3 TO TERMINAL 2 ON TRANSFORMER.
  - START ASSIST FACTORY EQUIPPED WHEN REQUIRED
  - USE COPPER CONDUCTORS ONLY.
  - USE N.E.C. CLASS 2 WIRE

SEE UNIT RATING PLATE FOR TYPE AND SIZE OF OVER CURRENT PROTECTION

208-240/1/60 0140G00407

Wiring is subject to change. Always refer to the wiring diagram on the unit for the most up-to-date wiring.

# WIRING DIAGRAMS

**\*PC1460H41\*\***

**WARNING**  
HIGH VOLTAGE!  
DISCONNECT ALL POWER BEFORE SERVICING OR INSTALLING THIS UNIT. MULTIPLE POWER SOURCES MAY BE PRESENT. FAILURE TO DO SO MAY CAUSE PROPERTY DAMAGE, PERSONAL INJURY OR DEATH.

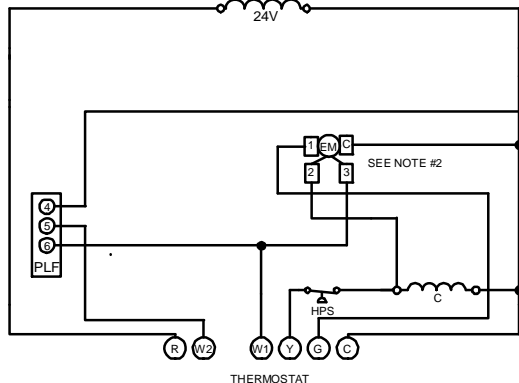
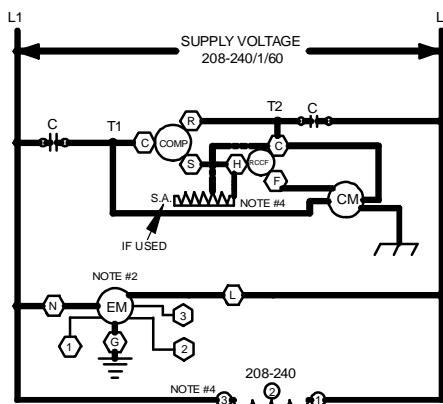
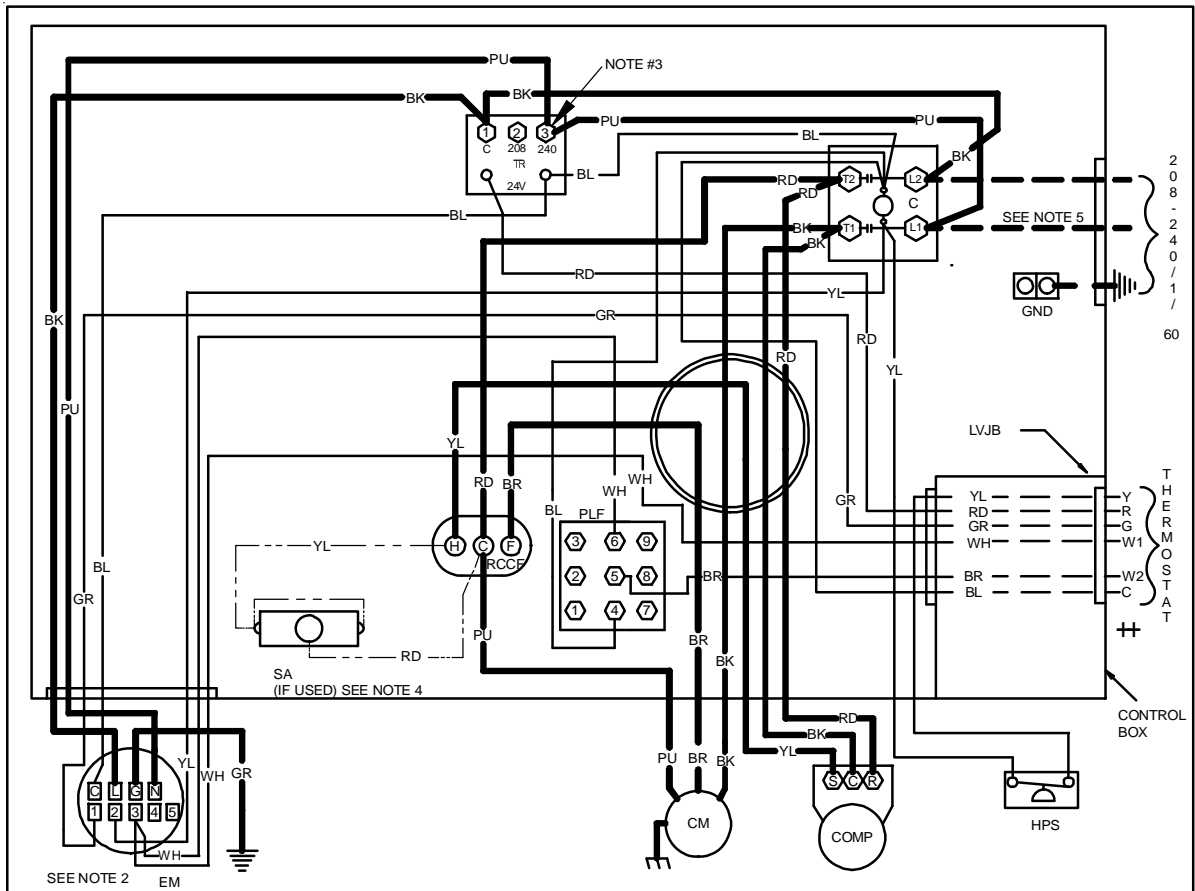

**COMPONENT LEGEND**

C CONTACTOR  
 CM CONDENSER MOTOR  
 COMP COMPRESSOR  
 EM EVAPORATOR MOTOR  
 GND EQUIPMENT GROUND  
 LVJB LOW VOLTAGE JUNCTION BOX  
 PLF FEMALE PLUG / CONNECTOR  
 RCCF RUN CAPACITOR FOR COMPRESSOR AND FAN  
 SA START ASSIST  
 TR TRANSFORMER  
 HPS HIGH PRESSURE SWITCH

**FACTORY WIRING**

— LINE VOLTAGE  
 — LOW VOLTAGE  
 - - - OPTIMAL HIGH VOLTAGE

**FIELD WIRING**

● HIGH VOLTAGE  
 - - - LOW VOLTAGE

**WIRE CODE**

BK BLACK  
 BL BLUE  
 BR BROWN  
 GR GREEN  
 OR ORANGE  
 PU PURPLE  
 RD RED  
 WH WHITE  
 YL YELLOW

**NOTES:**

- REPLACEMENT WIRE MUST BE SAME SIZE AND TYPE INSULATION AS ORIGINAL (AT LEAST 105°C) USE COPPER CONDUCTOR ONLY.
  - TO CHANGE EVAPORATOR MOTOR SPEED MOVE WHITE AND YELLOW LEADS FROM EM "2" AND "3" TO "4" AND "5". IF BOTH LEADS ARE ENERGIZED, THE HIGHER SPEED SETTING IS USED.
  - FOR 208 VOLT TRANSFORMER OPERATION MOVE PURPLE WIRES FROM TERMINAL 3 TO TERMINAL 2 ON TRANSFORMER.
  - START ASSIST FACTORY EQUIPPED WHEN REQUIRED
  - USE COPPER CONDUCTORS ONLY.
- ++ USE N.E.C. CLASS 2 WIRE

SEE UNIT RATING PLATE FOR TYPE AND SIZE OF OVER CURRENT PROTECTION

208-240/1/60 0140G00871 REV. B

Wiring is subject to change. Always refer to the wiring diagram on the unit for the most up-to-date wiring.