



COMPACT POWER RAKE Owner's Manual

CR550HC, CR550H, CR550HCEU

Accessories

Replacement Parts

<p>SLICING REEL</p> <p>A complete verticising reel for your CR. 20" wide reel for use in grasses that require vertical cutting, and for assisting in lawn overseeding projects.</p> <p>P/N 350252</p>	<p>SLICING BLADES</p> <p>A full set of twenty blades for replacement. Includes 40 new capscrews, and lock nuts for replacement installation.</p> <p>P/N 350187</p>	<p>SPACER BUMPERS</p> <p>A complete replacement set. 44 of 1/2" spacer bumpers and 4 of 1/4" spacer bumpers</p> <p>P/N 350258</p>	<p>DRIVE BELT</p> <p><i>Original Equipment drive belt for your CR.</i></p> <p>P/N 350207</p>	<p>FLAIL BLADES</p> <p>A complete replacement set. 60 of our high quality flail blades for your CR. Includes 8 new lock clips for replacement installation.</p> <p>P/N 350251</p>	<p>FLAIL SHAFTS</p> <p>A full set of four shafts for replacement. Includes 8 new lock clips for replacement installation. <i>NOTE: We recommend replacing the shafts when you replace flails.</i></p> <p>P/N 350185</p>
---	--	---	--	---	---



CR POWER RAKE Owner's Manual

ABOUT THIS MANUAL

THANK YOU for purchasing a BILLY GOAT® CR Power Rake. Your new machine has been carefully designed and manufactured to provide years of reliable and productive service. This manual provides complete operating and maintenance instructions that will help to maintain your machine in top running order. Read this manual carefully before assembling, operating, or servicing your equipment.

CONTENTS

SPECIFICATIONS/SOUND AND VIBRATION _____	3
INTENDED USE & INSTRUCTION LABELS _____	4
PACKING CHECKLIST & ASSEMBLY _____	5
OPERATION _____	6-7
MAINTENANCE _____	8-9
TROUBLESHOOTING AND WARRANTY PROCEDURE _____	9
PART ILLUSTRATION & PARTS LIST _____	10-13



CR POWER RAKE Owner's Manual

SPECIFICATIONS

	CR550H	CR550HC	CR550HCEU
Engine: HP	5.4 (4.0kW)	5.0 (3.73 kW)	5.0 (3.73 kW)
Engine: Model	X160TQX2	GC160AQHA	GC160AQHL
Engine: Type	HONDA OHC	HONDA OHC	HONDA OHC
Engine: Fuel Capacity	3.8 qt (3.6L)	2.1 qt (2.0 L)	2.1 qt (2.0 L)
Engine: Oil Capacity	0.63 qt (0.6L)	0.63 qt. (0.6 L)	0.63 qt. (0.6 L)
Total Unit Weight:	125# (56.8 kg)	125# (56.8 kg)	125# (56.8 kg)
Max. operating slope	20°	20°	20°
In accordance with 2000/14/EEC standards	99 dB(a)	99 dB(a)	99 dB(a)
Sound at operator's ear	81 dB(a)	81 dB(a)	81 dB(a)
Vibration at operator position	1.01g (9.94 m/s ²)	1.01g (9.94 m/s ²)	1.01g (9.94 m/s ²)

SOUND



99

SOUND LEVEL 81 dB(a) at Operator Position

Sound tests were conducted in accordance with 2000/14/EEC, and were performed on 2-9-2002 under the conditions listed below.

⚠ Sound power level listed is the highest value for any model covered in this manual. Please refer to serial plate on the unit for the sound power level for your model.

General Conditions:	Sunny
Temperature:	43°F (6.1°C)
Wind Speed:	10 mph (16.1 kmh)
Wind Direction:	North West
Humidity:	82.2%
Barometric Pressure:	29.72Hg (754 mm Hg)

VIBRATION DATA

VIBRATION LEVEL 1.01g (9.94m/s²)

Vibration levels at the operator's handles were measured in the vertical, lateral and longitudinal directions using calibrated vibration test equipment. Tests were performed on 5-25-2006 under the conditions listed below.

General Conditions:	Sunny
Temperature:	72.32°F (22.4°C)
Wind Speed:	3.8 mph (6.12kph)
Wind Direction:	East
Humidity:	62.2%
Barometric Pressure:	29.9Hg (101.3kpa)



CR POWER RAKE Owner's Manual

INTENDED USE

INTENDED USE

This machine is designed for removing thatch from your lawn, renovation of existing lawns, and to assist in overseeding operations. The machine should not be used for any other purpose than that stated above.

DO NOT operate if excessive vibration occurs. If excessive vibration occurs, shut engine off immediately and check for damaged or worn reel, loose pulley bolts or set screws, loose engine or lodged foreign objects. (See troubleshooting section on page 9).

INSTRUCTION LABELS

The labels shown below were installed on your BILLY GOAT® CR Power Rake. If any labels are damaged or missing, replace them before operating this equipment. Item numbers from the Illustrated Parts List and part numbers are provided for convenience in ordering replacement labels. The correct position for each label may be determined by referring to the Figure and Item numbers shown.



LABEL DANGER KEEP HANDS AND FEET AWAY
ITEM #51 P/N 400424



LABEL CLUTCH ITEM #49
P/N 830503



DANGER FLYING DEBRIS
ITEM # 48 P/N 810736



LABEL CAUTION GUARD
ITEM #52 P/N 900327

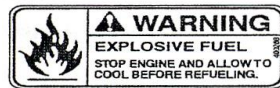

LABEL EXPLOSIVE FUEL
ITEM # 50 P/N 400268



LABEL INSTRUCTION HEIGHT ADJ.
ITEM #35 P/N 350224

ENGINE LABELS/CONTROLS

HONDA

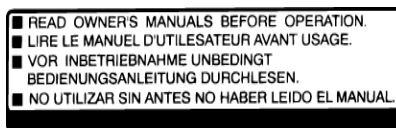
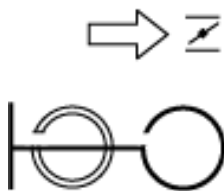

Controls CR550H

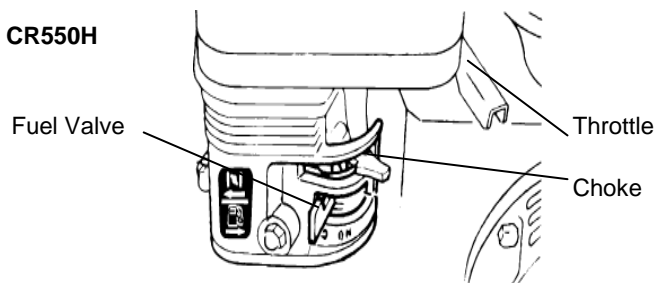



CR POWER RAKE Owner's Manual

PACKING CHECKLIST

NOTE: Items in () can be referenced in the Parts Illustration and Parts List on pages 10-11.

Your Billy Goat Power Rake is shipped from the factory in one carton, completely assembled.



READ all safety instructions before assembling unit.

TAKE CAUTION when removing the unit from the box the Handle Assembly is attached and folded over.



PUT OIL IN ENGINE BEFORE STARTING

PARTS BAG & LITERATURE ASSY

Warranty card P/N- 400972, Owner's Manual P/N-350245, Declaration of Conformity P/N-350139, General Safety and Warnings manual P/N-100295, and Literature CR Accessories 350246.

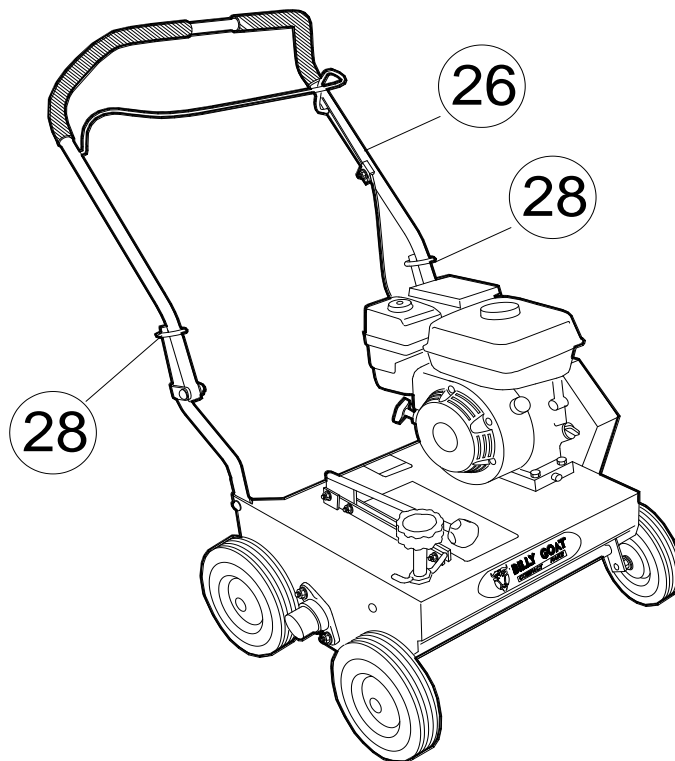

Boxing Parts Checklist

- Honda GC 5.0 OHC
- Literature Assy P/N-350243

ASSEMBLY

NOTE: Items in () can be referenced in the Parts Illustration and Parts list on pages 10-11.

1. **UNFOLD** the upper handle (item 26) and slide handle lock loops (item 28) into place to secure the upper handle to the lower.
2. **CHECK** engine oil level and fill to proper level with engine manufacturers recommended grade of oil. Move height adjust lever to down position, to level engine during checking. See engine manufacturer's instruction manual.
3. **CONNECT** spark plug wire.



CR POWER RAKE Owner's Manual

OPERATION

STARTING ENGINE

See engine manufacturer's instructions for type and amount of oil and gasoline used. Engine must be level when checking and filling oil and gasoline.

FUEL VALVE: Move fuel valve to "ON" position (when provided on engine).

STOP SWITCH: Located on the engine. "slow/stop" position.

CHOKER: Operated with choke lever on side of engine.

THROTTLE: Controlled by throttle lever on the motor.

If your unit fails to start, check the troubleshooting section on page 9 and also see the engine manual.

SLICING OPERATION

NOTE: NEVER PARK THIS UNIT ON A SLOPE OF ANY KIND. Always keep the reel in the up position when parking the unit.

BLADE POSITION & DEPTH CONTROL LEVER: The blades can be raised or lowered into the ground by height adjustment lever on the engine base. The resulting blade depth can be adjusted higher or lower. (See Fig. 1 & 2)

ADJUSTING BLADE DEPTH: The depth of the blades can be raised or lowered by rotating the knob on the top of the adjustment lever. The blades are lowered by rotating the knob counter-clockwise, and raised by rotating the knob clockwise. The relative depth of the blades can be gauged by using the depth scale located on the right front corner of the engine base. (See Fig. 3)

FOLDING HANDLE: This unit is equipped with a folding upper handle for easier storage and transportation. The handle can be folded by sliding the handle lock loops up (item 28). This releases the upper handle, allowing it to be folded over the unit.

HANDLING & TRANSPORTING: This unit requires two people to lift it. With the handle in the folded position, lift holding the lower handle and belt/shaft guard one on each side of the machine. Secure the machine in place during transport.

 Never lift the machine while the engine is running.

STORAGE:  Never store engine indoors or in enclosed poorly ventilated areas with fuel in tank, where fuel fumes may reach an open flame, spark or pilot light, as on a furnace, water heater, clothes dryer or other gas appliance. If engine is to be unused for 30 days or more, prepare as follows:

 Remove all gasoline from carburetor and fuel tank to prevent gum deposits from forming on these parts and causing possible malfunction of engine. Drain fuel outdoors, into an approved container, away from open flame. Be sure engine is cool. Do not smoke. Run engine until fuel tank is empty and engine runs out of gasoline.

RAKING OPERATION

SET DEPTH: With engine off, set the raking depth so that the blades just touch on a flat surface (i.e. driveway, or sidewalk).

ENGAGE BLADES: Pull back on the bail on the operators handle. **NOTE:** When engaging the blades in heavy load conditions, i.e. heavy thatch or very uneven turf, push down on the operators handle lifting the front wheels slightly. Engage the blades. Slowly lower the unit into the turf.

RAKE: Rake a small test area and examine the results. Thatch should be removed and deposited on top of the healthy grass. If excessive damage occurs to healthy grass, adjust the blade depth to decrease damage. Continue raking the yard, working in one direction (i.e. north-south, or east-west). **NOTE:** If a large drop in engine RPM occurs, or the unit pulls you forward and bounces during operation, the blade depth is set too low.

REMOVE THATCH: After raking, a layer of thatch will be deposited over the top of the lawn. This thatch must be removed prior to any fertilizing, seeding, or watering of the lawn. We suggest the use of a lawn vacuum or wheeled blower for collection and removal of the thatch.

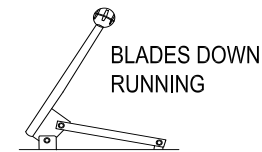
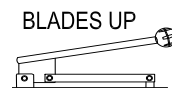

Fig. 1

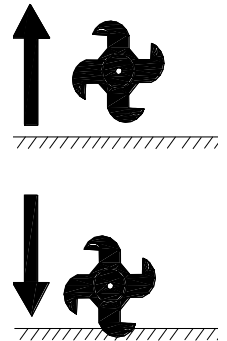

Fig. 2

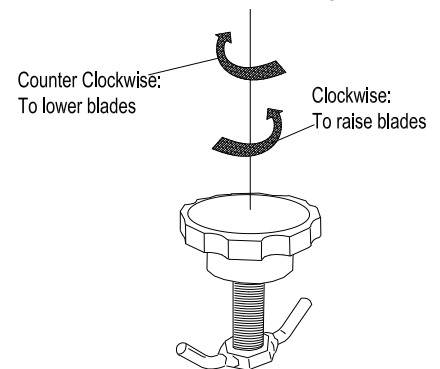

Fig. 3



CR POWER RAKE Owner's Manual

VERTI-CUTTING OPERATION

SET DEPTH: With engine off, set the raking depth so that the blades just touch on a flat surface (i.e. driveway, or sidewalk).

ENGAGE BLADES: Pull back on the bail on the operator's handle. *NOTE:* When engaging the blades in heavy load conditions (i.e. heavy thatch, or very uneven turf), push down on the operator's handle lifting the front wheels slightly. Engage the blades. Slowly lower the unit into the turf.

SLICE: Verti-cut a small test area and examine the results. Some thatch and cut stems should be removed and deposited on top of the healthy grass. Grass runners should be cut and ready for removal. If excessive damage occurs to healthy grass, adjust the blade depth to decrease damage. Continue raking the yard, working in one direction (i.e. north-south, or east-west). *NOTE:* If a large drop in engine RPM occurs, or the unit pulls you forward and bounces during operation, the blade depth is set too low.

REMOVE THATCH/STEMS: After verti-cutting, a layer of thatch and cut stems will be deposited over the top of the lawn. We suggest the use of a lawn vacuum or wheeled blower for collection and removal of the thatch/stems.

*****TIPS*****

MOW

Mow the lawn to its normal cut height.

DRY

Be sure grass is dry. Wet conditions can cause increased damage to healthy grass.

INSPECT

Check the lawn before beginning work. Remove all rocks, wire, string, or other objects that can present a hazard during work prior to starting.

IDENTIFY

Mark all fixed objects to be avoided during work, such as sprinkler heads, water valves, buried cables, or clothes line anchors, etc.

THATCH

Thatch is a dense layer of dead grass, clippings, and roots that builds up over time at the base of the lawn preventing air, water, and fertilizer from reaching the soil. This can cause shallow root development and make a lawn more susceptible to drought and disease. Thatch also provides an ideal environment for insects to hide and multiply. Periodic removal of thatch will keep your lawn in good health.

HEAVY THATCH

Lawns with an excessive amount of thatch will require multiple treatments for effective removal. Trying to remove excessive thatch (greater than 3/4"[19 mm] deep) in one treatment will damage or destroy the living part of the lawn. It is best to remove heavy thatch in seasonal treatments (i.e. spring, and fall).

CHECK

Before beginning, it is best to evaluate the condition of the lawn by cutting one or more core samples from the area to be treated. A core can be cut using a piece of pvc, or metal pipe. Hammer the pipe into the ground, remove it, push the core out of the pipe and inspect it to determine the depth of thatch in your yard.

SLOPES

Rake slopes across not up and down the slope. This is much easier and safer for the operator and is better for the lawn. Raking across will help to reduce runoff during watering and allow the sloped ground to hold more seed, fertilizer, and water. The units maximum operating slope is 35% or 19°.

DEPTH

The wide range of depth adjustment on your unit is provided to allow for blade wear. Setting the reel deeper will not produce better, or quicker results. The flail reel is intended to be set so it just touches the surface on flat ground. The slicing reel should be set even with the ground for verti-slicing work, and set to a maximum 1/2" depth for overseeding jobs. Setting the reel deeper than this will only result in premature wear on the unit (i.e. failed belt). If you desire to work the ground deeper than the above guidelines allow, it should be done gradually in multiple passes.



CR POWER RAKE Owner's Manual

MAINTENANCE

PERIODIC MAINTENANCE

NOTE: Items in () can be referenced in the Parts Illustration and Parts List on pages 10-11.

Periodic maintenance should be performed at the following intervals:

Maintenance Operation	Every Use (daily)	Every 25 Hours
Inspect for loose, worn or damaged parts		●
Check engine oil	●	
Inspect belt		●
Engine (See Engine Manual)		
Grease reel bearings		●
Inspect and clean engine air filter	●	
Oil height adjustment linkage		●

FLAIL BLADE WEAR

1. Wait for engine to cool and disconnect spark plug.
2. Close fuel valve on engine. (Honda only)
3. Lean unit back onto lower handles and secure in place.
4. Inspect blades for wear, and immediately replace any bent, or cracked blades. Measure the overall length of the blade. (See Fig. 4)
5. If blades measure less than 3.0"(76 mm) in overall length, they must be replaced. *NOTE:* We recommend replacing all the flails at once.

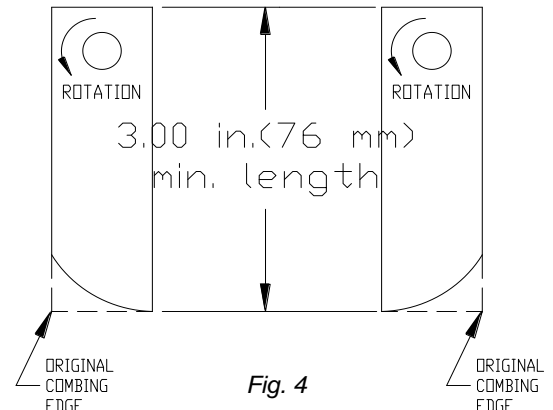

Fig. 4

SLICING BLADE WEAR

1. Wait for engine to cool and disconnect spark plug.
2. Close fuel valve on engine. (Honda only)
3. Lean unit back onto lower handles and secure in place.
4. Inspect blades for wear, and immediately replace any bent or cracked blades. Measure the overall length of the blade from the center of the attachment bolts to the tip of the worn blade.
5. If blades measure less than 3.0"(76 mm) they must be replaced. *NOTE:* We recommend replacing all the blades at once.

ROTATING FLAIL REEL END TO END

To maximize flail blade life and performance, the reel can be rotated end to end periodically to provide a fresh lead cutting edge. Takes approx. 20 min. and requires two 1/2" socket wrenches with extension bar.

1. Wait for engine to cool and disconnect spark plug.
2. Close fuel valve on engine.
3. Lean unit back onto lower handles and secure in place.
4. Remove six screws (item 65) holding the belt and shaft guards (item 21 & 22) in place. It is necessary to lower the height adjust lever to reach the locknuts on the guards. Remove the guards.
5. Remove the drive belt (item 9) by "walking" it out of the groove on the reel pulley (item 2).
6. Remove the four lock nuts (item 47) and washers (item 35) holding the bearings (item 23) to the frame of the unit.
7. The reel (item 6) is now free from the machine. Slide the reel down and out of the machine.
8. Remove the capscrew (item 58), lock washer (item 57), reel pulley (item 2), key (item 75), and reel spacer (item 10) from the end of the reel.
9. Rotate the reel end to end, and re-install these items on the opposite end of the reel.
10. Re-install the reel in reverse order of removal. Re-install the guards in reverse order of removal.



CR POWER RAKE Owner's Manual

DRIVE BELT REPLACEMENT

NOTE: Takes approx. 10 min. and requires 3/8" socket wrench with extension.

1. Wait for engine to cool and disconnect spark plug.
2. Remove six self-tapping screws (item 65) holding the belt guard (item 21 & 22) in place. Remove the guard.
3. Remove the belt (item 9) by rotating the reel pulley (item 2) and walking it out of the groove. Discard old belt
4. Install new belt using same procedure to walk the belt into the groove.
5. With new belt installed, pull bail rod back to engaged position and measure extension of idler spring. Spring should stretch 1" to 1.25" (25-32 mm) with bail engaged. Adjust clutch cable as necessary to achieve this extension.
6. Re-install the belt guard.

TROUBLESHOOTING

Problem	Possible Cause	Solution
Abnormal vibration	Damaged or missing blades. Loose handle bolts. Loose engine bolts.	Stop work immediately. Replace any damaged or missing blades. Tighten all loose nuts and bolts.
Engine stalls or labors when raking	Blades set too deep into ground.	Raise blades so that they just touch the ground on a level surface.
Engine will not start	Throttle in off position. Out of gasoline or bad, old gasoline. Spark plug wire disconnected. Gas valve off. Dirty air cleaner.	Check choke position. Check gasoline. Connect spark plug wire. Turn on gas valve. Clean or replace air cleaner. Contact a qualified service person.
Engine is locked, will not pull over	Debris locked against reel, or drive pulleys. Engine problem.	Pull spark plug wire and remove debris. Contact an engine servicing dealer for engine problems.



CR POWER RAKE Owner's Manual

CR PARTS DRAWING

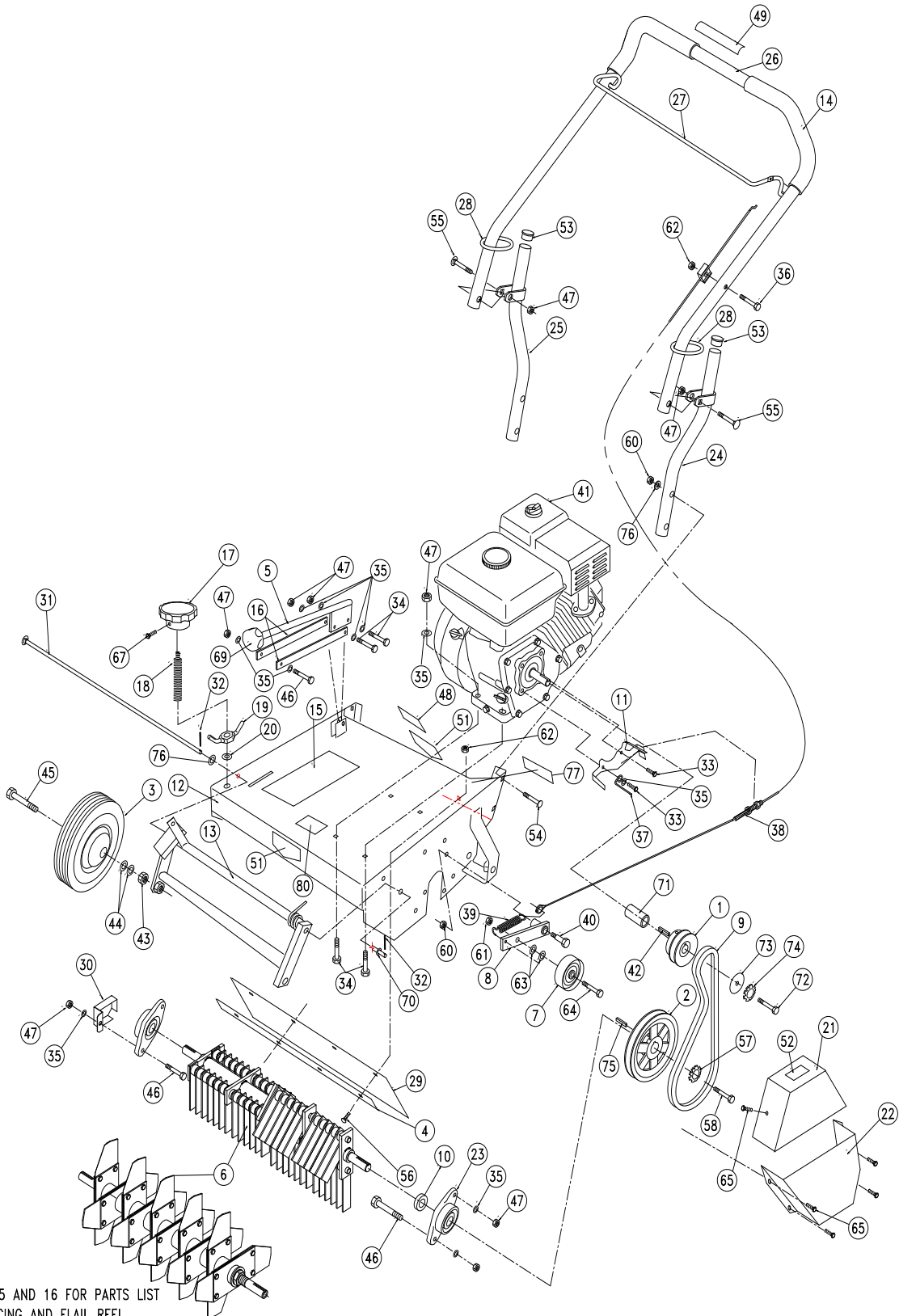

SEE PAGE 15 AND 16 FOR PARTS LIST
FOR SLICING AND FLAIL REEL



CR POWER RAKE Owner's Manual

CR PARTS LIST

item no.	PARTS LIST	CR550HC Part No.	QTY	CR550HCEU Part No.	QTY	CR550H Part No.	QTY
1	Pulley 3.0" O.D.	350101	1	350101	1	350101	1
2	Pulley 5.5" O.D. X 3/4"	350206	1	350206	1	350206	1
3	Wheel 8" Semi-Pneu White	350236	4	350236	4	350236	4
4	Bar Strap	350211	1	350211	1	350211	1
5	Rod Height Wa	350220	1	350220	1	350220	1
6	Reel Flail Assy (see page 10 & 11 for parts list and detailed dwg.)	350241-S	1	350241-S	1	350241	1
7	Pulley Idler 2.75"	350114	1	350114	1	350114	1
8	Arm Idler WA	350115	1	350115	1	350115	1
9	Belt 5L X 34"	350207	1	350207	1	350207	1
10	Spacer Reel Pulley	350118	1	350118	1	350118	1
11	Bracket Belt Finger	350208	1	350208	1	350208	1
12	Chassis WA W/ Label	350235	1	350235	1	350235	1
13	Frame Front WA	350213	1	350213	1	350213	1
14	GRIP 1" x 13"	400570	2	400570	2	400570	2
15	Label Instr. Hgt. Adj.	350224	1	350224	1	350224	1
16	Link Height Bar	350223	2	350223	2	350223	2
17	Knob Height Adj.	850154	1	850154	1	850154	1
18	STUD 3/4"-10 X 5 1/2" PLTD	810538	1	810538	1	810538	1
19	LOCKNUT ASSY	800227	1	800227	1	800227	1
20	WASHER 3/4" NYLON	800109	1	800109	1	800109	1
21	Guard Belt Top Wa	350248	1	350248	1	350248	1
22	Guard Belt Bottom Wa	350249	1	350249	1	350249	1
23	Bearing 3/4" Cast Flange	350209	2	350209	2	350209	2
24	Handle Lower LH WA	350134	1	350134	1	350134	1
25	Handle Lower RH WA	350135	1	350135	1	350135	1
26	Handle Upper PR500	350136	1	350136	1	350136	1
27	Bail Clutch WA	350137	1	350137	1	350137	1
28	Loop Folding Handle	350138	2	350138	2	350138	2
29	Deflector Rubber	350210	1	350210	1	350210	1
30	Guard Shaft CR	350250	1	350250	1	350250	1
31	PIN LIFT FRONT 3/8" X 21 3/16" Long	350212	1	350212	1	350212	1
32	PIN COTTER 1/8" X 1" Z/P	900471	1	900471	1	900471	1
33	SCREWCAP 5/16-24x3/4" GR5	8042026	2	8042026	2	8042026	2
34	SCREWCAP 5/16 - 18 x 1 1/2	8041030	6	8041030	6	8041030	6
35	WASHER 1/4" FLAT Z/P	8171002	13	8171002	13	8171002	13
36	SCREWCAP 1/4"-20X1.5"	8041008	1	8041008	1	8041008	1
37	BELT FINGER WIRE	350301	1	350301	1	350301	1
38	Cable Clutch Reel PR500	350181	1	350181	1	350181	1
39	Spring Extension	350300	1	350300	1	350300	1
40	Bolt Shoulder 1/2" X 1"	500114	1	500114	1	500114	1
41	ENGINE HONDA 5.0 HP (CR550HC), HONDA 5.5 (CR550H)	430272	1	430272	1	600115	1
	ENGINE HONDA 5.5 HP (CR550H)	600115	1	600115	1		
	ENGINE HONDA 5HP (CR550HCEU)			350426EU	1		
42	KEY 3/16" X 1"	9201078	1	9201078	1	9201078	1
43	NUT 1/2 - 13 JAM	8162005	4	8162005	4	8162005	4
44	WASHER 1/2 SAE	8172011	8	8172011	8	8172011	8
45	SCREWCAP 1/2-13 x 3" Z/P	8041102	4	8041102	4	8041102	4
46	SCREWCAP 5/16"-18X1 1/4" HCS ZP	8041029	5	8041029	5	8041029	5
47	NUT LOCK 5/16-18	8160002	13	8160002	13	8160002	13
48	LABEL DANGER THROWN OBJECT	810736	1	810736	1	810736	1
49	LABEL CLUTCH VQ	830503	1	830503	1	830503	1
51	LABEL WARNING	400424	2	400424	2	400424	2
52	LABEL DANGER GUARD	900327	1	900327	1	900327	1
53	PLUG CAP 1" RD	890132	2	890132	2	890132	2
54	BOLT CARRAIGE 3/8-16 x 1 3/4	8024061	4	8024061	4	8024061	4
55	BOLT CARRAIGE 5/16-18 x 1 3/4	8024043	2	8024043	2	8024043	2
56	SCREWCAP 1/4-20x1"	8041006	4	8041006	4	8041006	4
57	LOCK WASHER TWISTED TOOTH	400502	1	400502	1	430502	2
58	SCREWCAP 3/8-16x1" REEL ASSEMBLY	8041050	1	8041050	1	8041050	1
60	NUT LOCK 3/8-16	8160003	5	8160003	5	8160003	5
61	NUT LOCK 3/8-16 THIN	8161042	1	8161042	1	8161042	1
62	NUT LOCK 1/4-20	8160001	5	8160001	5	8160001	5
63	WASHER 5/16 FLAT CUT	8171003	2	8171003	2	8171003	2
64	SCREWCAP 3/8-16x1.5"	8041052	1	8041052	1	8041052	1
65	SCREWCAP SHEET METAL DRILL POINT 1/4X3/4	430208	6	430208	6	430208	6
67	SCREW MACH. #10-24X2"	8059143	1	8059143	1	8059143	1
69	Knob Height Adj.	430128	1	430128	1	430128	1
70	WASHER 5/16 SAE	8172009	1	8172009	1	8172009	1
71	SPACER CRANK CR HONDA	350338	1	350338	1	350338	1
72	SCREWCAP 5/16-24 x 1 1/4" GR. 8	400389	1	400389	1	400389	1
74	WASHER TWISTED TOOTH	400389	1	400389	1	400389	1
75	KEY 3/16" X 5/8"	9201072	1	9201072	1	9201072	1
76	3/8 FLAT CUT WASHER	8171004	5	8171004	5	8171004	5
77	LABEL SPARK ARRESTOR	100256	1	100256	1	100256	1



CR POWER RAKE Owner's Manual

FLAIL REEL ASSY 350241-S

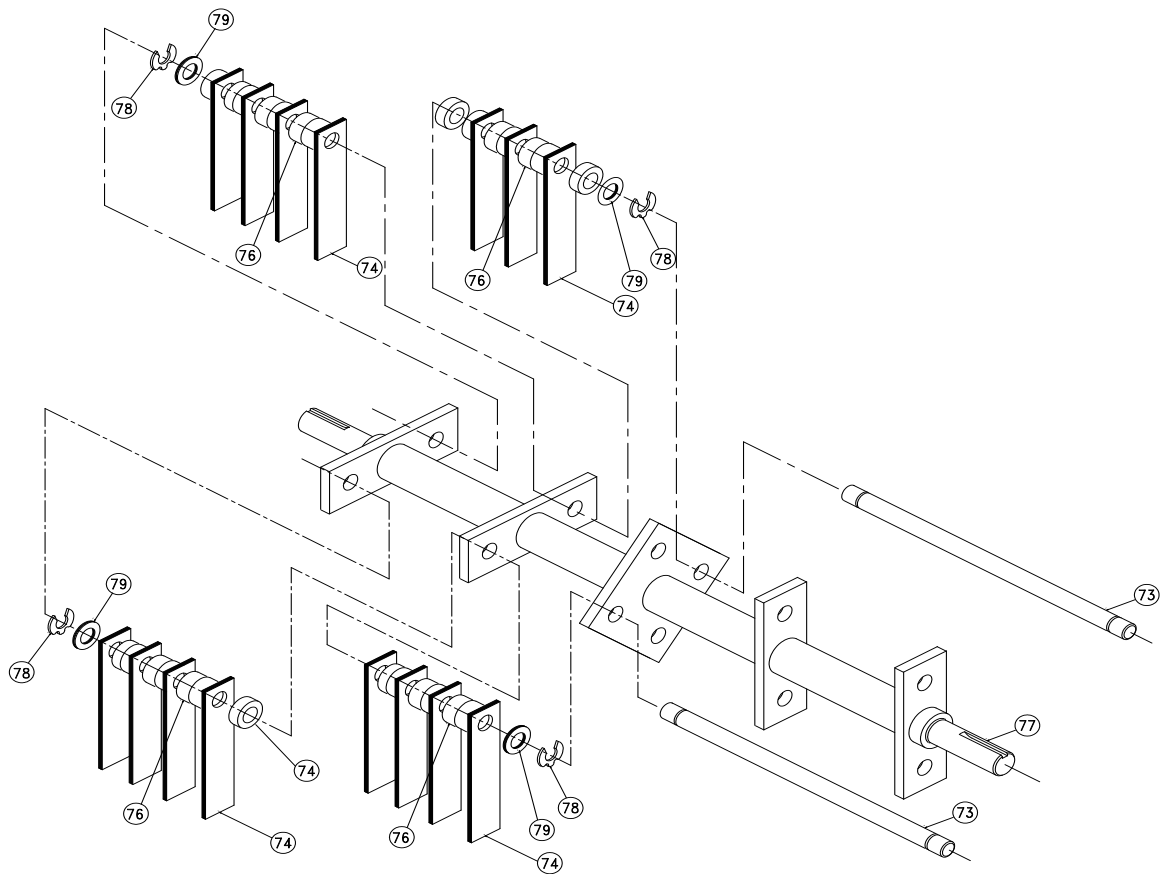

item no.	PARTS LIST	Part No.	QTY
73	SHAFT FLAIL BLADE	350141	4
74	BLADE FLAIL	350205	60
76	SPACER BUMPER 5/8" x 1/2"	350144	54
77	SHAFT WA FLAIL REEL	350145	1
78	CLIP LOCK 1/2"	350146	8
79	WASHER 1/2 SAE	8172011	8

FLAIL SHAFT KIT 350185

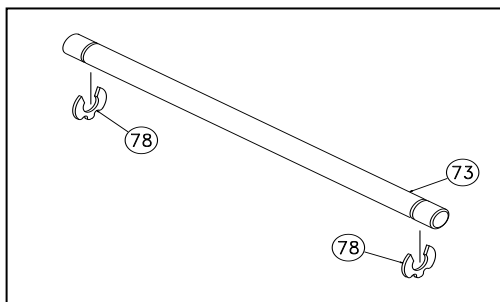

item no.	PARTS LIST	Part No.	QTY
73	SHAFT FLAIL BLADE	350141	4
78	CLIP LOCK 1/2"	350146	8

FLAIL BLADE KIT 350251

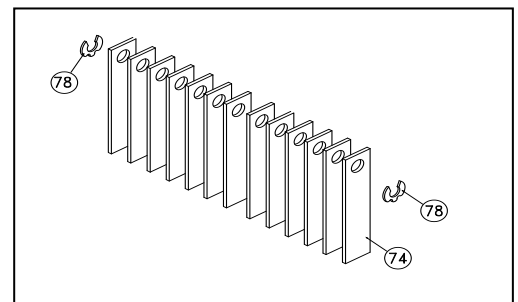

item no.	PARTS LIST	Part No.	QTY
74	BLADE FLAIL	350205	60
78	CLIP LOCK 1/2"	350146	8



CR POWER RAKE Owner's Manual

SPACER BUMPER KIT 350258

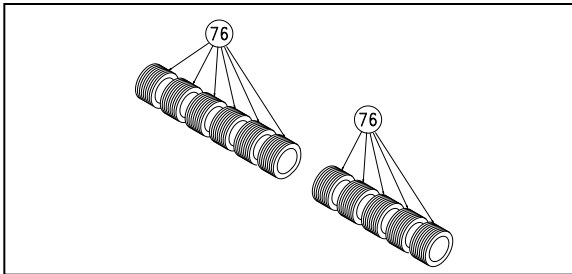

item no.	PARTS LIST	Part No.	QTY
76	SPACER BUMPER 5/8" x 1/2"	350144	54

SLICING BLADE KIT 350187

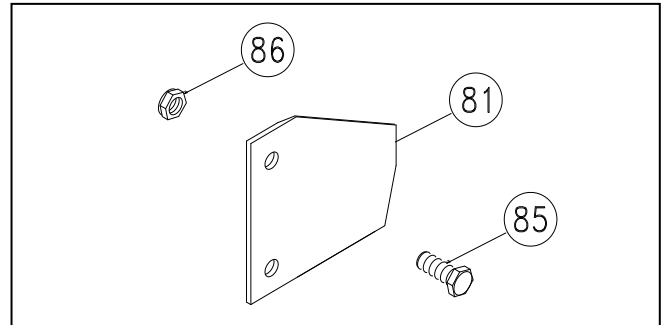

item no.	PARTS LIST	PR500 Part No.	QTY
81	BLADE SLICING REEL	350147	20
85	SCREWCAP 1/4-20 X 3/4 HCS ZP	8041004	40
86	NUT LOCK 1/4-20	8142004	40

SLICING REEL ASSY 350252

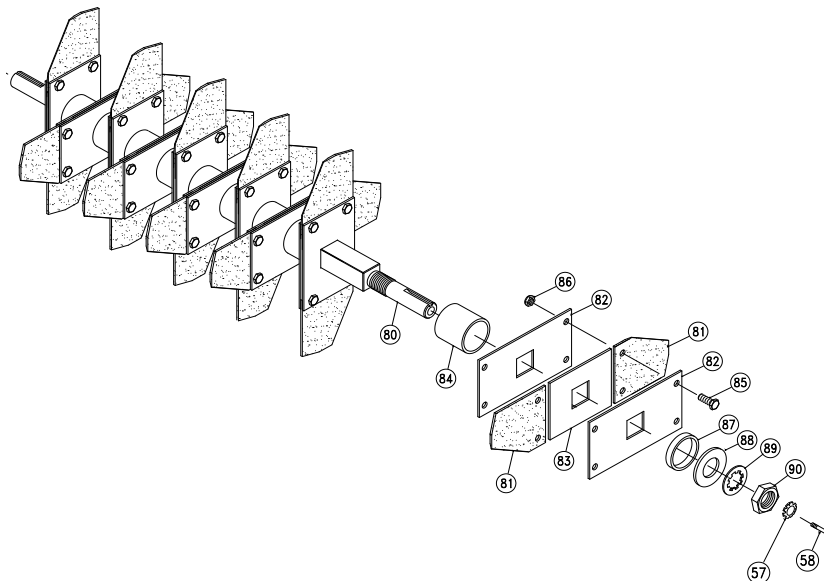

item no.	PARTS LIST	PR500 Part No.	QTY
57	LOCK WASHER 5/16 TWISTED TOOTH	430298	1
58	SCREWCAP 5/16 - 24 X 1" GR. 5	400164	1
80	SHAFT SLICING WA	350142	1
81	BLADE SLICING REEL	350147	20
82	PLATE BLADE MTG.	350253	20
83	SPACER BLADE MTG.	350254	10
84	SPACER BLADE ASSY	350150	9
85	SCREWCAP 1/4-20 X 3/4 HCS ZP	8041004	40
86	NUT LOCK 1/4-20	8142004	40
87	COLLAR SPACER	350152	1
88	WASHER 0.937 x 1.750 x 0.119	350153	1
89	WASHER LOCK 7/8 INT. TOOTH	350154	1
90	NUT JAM 7/8-14	350155	1