

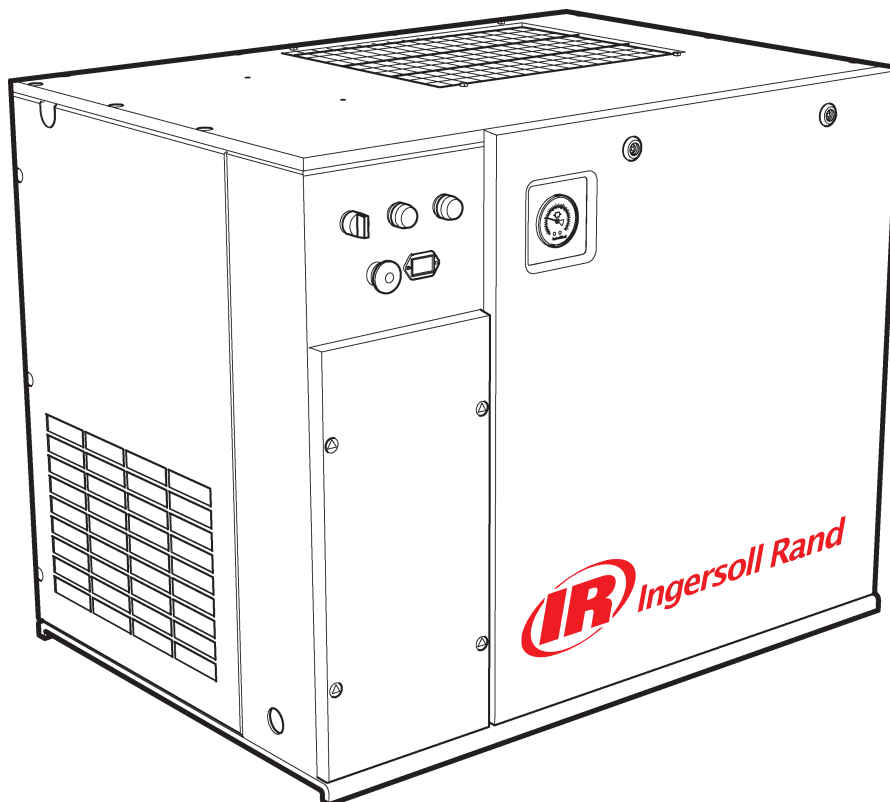

SSR UP5-4, UP5-5.5, UP5-7.5, UP5-11c
50 Hz

SSR UP6-5, UP6-7.5, UP6-10, UP6-15c
60 Hz

OPERATION AND MAINTENANCE MANUAL



This manual contains important safety information and must be made available to personnel who operate and maintain this machine.

Refer all communications to the nearest Ingersoll Rand Full Service Distributor.

C.C.N. : 80445273

REV. : A

DATE : OCTOBER 2008

AIR COMPRESSOR GROUP BONDED WARRANTY & REGISTERED START UP

Warranty

The Company warrants that the equipment manufactured by it and delivered hereunder will be free of defects in material and workmanship for a period of twelve months from the date of placing the Equipment in operation or eighteen months from the date of shipment from the factory, whichever shall first occur. The Purchaser shall be obligated to promptly report any failure to conform to this warranty, in writing to the Company in said period, whereupon the Company shall, at its option, correct such nonconformity, by suitable repair to such equipment or, furnish a replacement part F.O.B. point of shipment, provided the Purchaser has stored, installed, maintained and operated such Equipment in accordance with good industry practices and has complied with specific recommendations of the Company. Accessories or equipment furnished by the Company, but manufactured by others, shall carry whatever warranty the manufacturers have conveyed to the Company and which can be passed on to the Purchaser. The Company shall not be liable for any repairs, replacements, or adjustments to the Equipment or any costs of labor performed by the Purchaser or others without Company's prior written approval.

The effects of corrosion, erosion and normal wear and tear are specifically excluded. Performance warranties are limited to those specifically stated within the Company's proposal. Unless responsibility for meeting such performance warranties are limited to specified tests, the Company's obligation shall be to correct in the manner and for the period of time provided above.

THE COMPANY MAKES NO OTHER WARRANTY OR REPRESENTATION OF ANY KIND WHATSOEVER, EXPRESSED OR IMPLIED, EXCEPT THAT OF TITLE, AND ALL IMPLIED WARRANTIES OF MERCHANTABILITY AND FITNESS FOR A PARTICULAR PURPOSE, ARE HEREBY DISCLAIMED.

Correction by the Company of nonconformities whether patent or latent, in the manner and for the period of time provided above, shall constitute fulfillment of all liabilities of the Company for such nonconformities whether based on contract, warranty negligence, indemnity, strict liability or otherwise with respect to or arising out of such Equipment.

The purchaser shall not operate Equipment which is considered to be defective, without first notifying the Company in writing of its intention to do so. Any such use of Equipment will be at Purchaser's sole risk and liability.

Note that this is Ingersoll Rand standard warranty. Any warranty in force at the time of purchase of the compressor or negotiated as part of the purchase order may take precedence over this warranty.

Register on-line at <http://air.ingersollrand.com>

Ingersoll Rand
Industrial Air Solutions
Swan Lane
Hindley Green
Wigan WN2 4EZ

Ingersoll Rand Asia Pacific
C/O Ingersoll Rand South East Asia (Pte) Ltd.
42 Benoi Road
Singapore 629903

Ingersoll Rand
Industrial Air Solutions
P.O. Box 1840
800-D Beatty Street
Davidson, NC 28036

CONTENTS	
FOREWORD	5
DECALS.	6
ISO SYMBOLS	6
GRAPHIC FORM AND MEANING OF ISO SYMBOLS	6
ANSI SYMBOLS	8
GRAPHIC FORM AND MEANING OF ANSI SYMBOLS	8
SAFETY.	11
General Information.	11
Compressed air	11
Materials	12
Transport.	12
Electrical	12
Condensate disposal	12
GENERAL INFORMATION	13
PIPING AND INSTRUMENTATION.	13
SCHEMATIC, ELECTRICAL UP6 5–15HP FV 3PH 60Hz DOL – U.S.A.	15
SCHEMATIC, ELECTRICAL UP6 5–15HP SD 3PH 60Hz	16
SCHEMATIC, ELECTRICAL UP6 5–15HP FV 1PH 60Hz - U.S.A.	17
SCHEMATIC, ELECTRICAL UP5 5–15HP FV 3PH 50Hz DOL	18
SCHEMATIC, ELECTRICAL UP5 5–15HP SD 3PH 50Hz	19
INSTALLATION/HANDLING.	20
UNPACKING	21
UP-SERIES TANK MOUNTED (80 GAL)	22
UP-SERIES TANK MOUNTED (120 GAL)	24
UP-SERIES TANK MOUNTED (272 LITRES)	26
UP-SERIES TANK MOUNTED (500 LITRES)	28
LOCATION IN THE PLANT.	30
DISCHARGE PIPING	30
ELECTRICAL DATA	35
OPERATING INSTRUCTIONS	36
GENERAL OPERATION.	36
COMPRESSOR CONTROLS	37
AUTOMATIC START & STOP CONTROL.	37
DUAL CONTROL.	37
PRIOR TO STARTING	38
STARTING	38
NORMAL/EMERGENCY STOPPING.	38
MAINTENANCE.	39
MAINTENANCE SCHEDULE.	39
ROUTINE MAINTENANCE.	40

TOP UP COOLANT PROCEDURE	41
COOLANT CHANGE PROCEDURE	41
COOLANT FILTER CHANGE PROCEDURE	41
AIR FILTER ELEMENT CHANGE PROCEDURE	41
SEPARATOR ELEMENT CHANGE PROCEDURE	42
COOLER CLEANING PROCEDURE	42
BELT CHECKING AND ADJUSTMENT PROCEDURE	42
ELECTRIC DRAIN VALVE (OPTIONAL)	43
PRODUCT DESCRIPTION	43
OPERATION.	43
TIMER SETTINGS	43
TROUBLESHOOTING	43
MAINTENANCE	43
MOISTURE SEPARATOR MAINTENANCE	44
AIR FILTER MAINTENANCE	44
DISASSEMBLING THE UNIT.	45
REFRIGERANT LEAKS IN THE REFRIGERATION CIRCUIT	45
REFRIGERANT CHARGING	45
CHARACTERISTICS OF REFRIGERANT R134A	45
TROUBLESHOOTING.	45
MAINTENANCE	45
TROUBLE SHOOTING.	46

ABBREVIATIONS & SYMBOLS

- ####** Contact **Ingersoll Rand** for serial number
- >####** Up to Serial No.
- ####->** From Serial No.
- *** Not illustrated
- †** Option
- NR** Not required
- AR** As required
- SM** Sitemaster/Sitepack
- HA** High ambient machine
- WC** Watercooled machine
- AC** Aircooled machine
- ERS** Energy recovery system
- T.E.F.C.** Totally enclosed fan cooled motor (IP54)
- O.D.P.** Open drip proof (motor)
- ppm** parts per million

FOREWORD

The contents of this manual are considered to be proprietary and confidential to **Ingersoll Rand** and should not be reproduced without the prior written permission of **Ingersoll Rand**.

Nothing contained in this document is intended to extend any promise, warranty or representation, expressed or implied, regarding the **Ingersoll Rand** products described herein. Any such warranties or other terms and conditions of sale of products shall be in accordance with the standard terms and conditions of sale for such products, which are available upon request.

This manual contains instructions and technical data to cover routine operation and scheduled maintenance tasks by operation and maintenance staff. Major overhauls are outside the scope of this manual and should be referred to an authorised **Ingersoll Rand** service department.

The design specification of this machine has been certified as complying with E.C. directives. Any modification to any part is absolutely prohibited and would result in the CE certification and marking being rendered invalid.

All components, accessories, pipes and connectors added to the compressed air system should be:

- of good quality, procured from a reputable manufacturer and, wherever possible, be of a type approved by **Ingersoll Rand**.
- clearly rated for a pressure at least equal to the machine maximum allowable working pressure.
- compatible with the compressor lubricant/coolant.
- accompanied with instructions for safe installation, operation and maintenance.

*Details of approved equipment are available from **Ingersoll Rand** Service departments.*

The use of non-genuine spare repair parts other than those included within the **Ingersoll Rand** approved parts list may create hazardous conditions over which **Ingersoll Rand** has no control. Therefore **Ingersoll Rand** does not accept any liability for losses caused by equipment in which non-approved repair parts are installed. Standard warranty conditions may be affected.

Ingersoll Rand reserves the right to make changes and improvements to products without notice and without incurring any obligation to make such changes or add such improvements to products sold previously.

The intended uses of this machine are outlined below and examples of unapproved usage are also given, however **Ingersoll Rand** cannot anticipate every application or work situation that may arise.

IF IN DOUBT CONSULT SUPERVISION.

This machine has been designed and supplied for use only in the following specified conditions and applications:

- Compression of normal ambient air containing no known or detectable additional gases, vapours, or particles
- Operation within the ambient temperature range specified in the GENERAL INFORMATION section of this manual.

The use of the machine in any of the situation types listed in table 1:-

- a. Is not approved by **Ingersoll Rand**,
- b. May impair the safety of users and other persons, and
- c. May prejudice any claims made against **Ingersoll Rand**.

TABLE 1

Use of the machine to produce compressed air for:

- a. direct human consumption
- b. indirect human consumption, without suitable filtration and purity checks.

Use of the machine outside the ambient temperature range specified in the GENERAL INFORMATION SECTION of this manual.

Use of the machine where there is any actual or foreseeable risk of hazardous levels of flammable gases or vapours.

THIS MACHINE IS NOT INTENDED AND MUST NOT BE USED IN POTENTIALLY EXPLOSIVE ATMOSPHERES, INCLUDING SITUATIONS WHERE FLAMMABLE GASES OR VAPOURS MAY BE PRESENT.

Use of the machine fitted with non **Ingersoll Rand** approved components.

Use of the machine with safety or control components missing or disabled.

The company accepts no responsibility for errors in translation of this manual from the original English version.











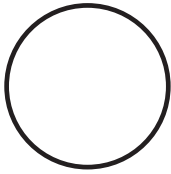
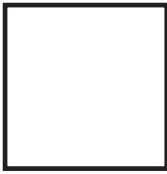



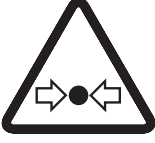

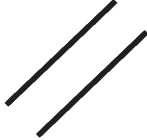

© COPYRIGHT 2008







INGERSOLL RAND

DECALS

ISO SYMBOLS

GRAPHIC FORM AND MEANING OF ISO SYMBOLS

		
Prohibition / Mandatory	Information / Instructions	Warning
 WARNING: Electrical shock risk	 WARNING – Pressurised vessel.	 WARNING – Hot surface.
 WARNING – Pressurised component or system.	 WARNING – Air/gas flow or Air discharge.	 Do not breathe the compressed air from this machine.
 Use fork lift truck from this side only.	 RESET	 Do not use fork lift truck from this side.
 Emergency Stop.	 On (power).	 Off (power).
 Read the Operation and Maintenance manual before operation or maintenance of this machine is undertaken.	 Do not operate the machine without the guard being fitted.	 Lifting point.
 ROTATION	 AIR DISCHARGE	 COOLANT FILTER

 <p>AUTOMATIC RESTART</p>	 <p>MAINTENANCE</p>	 <p>MAINTENANCE PROHIBITED</p>
 <p>COOLANT DRAIN</p>	 <p>CONDENSATE DRAIN</p>	 <p>FILTER</p>
 <p>FRAGILE</p>	 <p>KEEP DRY</p>	 <p>THIS WAY UP</p>
 <p>USE NO HOOKS</p>	 <p>NO SIDE CLAMPS</p>	 <p>HOURS</p>
 <p>Pinch point hazard. Keep hands clear.</p>	 <p>POWER</p>	 <p>INSPECT</p>
 <p>Every X months, if sooner than required by operating hours</p>	 <p>CHANGE / REPLACE</p>	 <p>CLEAN</p>
 <p>POWER INLET (AC)</p>		

ANSI SYMBOLS

GRAPHIC FORM AND MEANING OF ANSI SYMBOLS

 **DANGER**



INTAKE AIR. Can contain carbon monoxide or other contaminants. Will cause serious injury or death. **Ingersoll Rand** air compressors are not designed, intended or approved for breathing air. Compressed air should not be used for breathing air applications unless treated in accordance with all applicable codes and regulations.

 **WARNING**



HAZARDOUS VOLTAGE. Can cause serious injury or death. Disconnect power and bleed pressure from tank before servicing. Lockout/Tagout machine. Compressor must be connected to properly grounded circuit. See Grounding Instructions in manual. Do not operate compressor in wet conditions. Store indoors.



RISK OF FIRE OR EXPLOSION. Electrical arcing from compressor components can ignite flammable liquids and vapors which can result in serious injury. Never operate the compressor near flammable liquids or vapors. If used to spray flammable materials, keep compressor at least 20ft (6m) away from the spray area.



HIGH PRESSURE AIR. Rusted tanks can cause explosion and severe injury or death. Receiver under pressure. Operator should relieve tank pressure before performing maintenance. In addition to automatic drain, operate manual drain valve weekly. Manual drain valve located at bottom of the tank.



MOVING PARTS. Can cause serious injury. Do not operate with guards removed. Machine may start automatically. Disconnect power before servicing. Lockout/Tagout machine.



HOT SURFACES. Can cause serious injury. Do not touch. Allow to cool before servicing. Do not touch hot compressor or tubing.

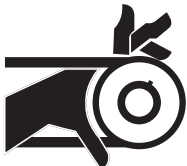

EXPOSED MOVING BELTS AND SHEAVES. Can cause severe injury or death. Do not operate without guard in place. Disconnect power before servicing. Lockout/Tagout machine.

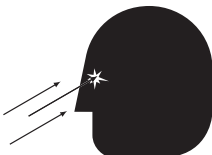

Air flow exhaust may contain flying debris. Safety protection should be worn at all times.



Pinch point hazard. Keep hands clear.

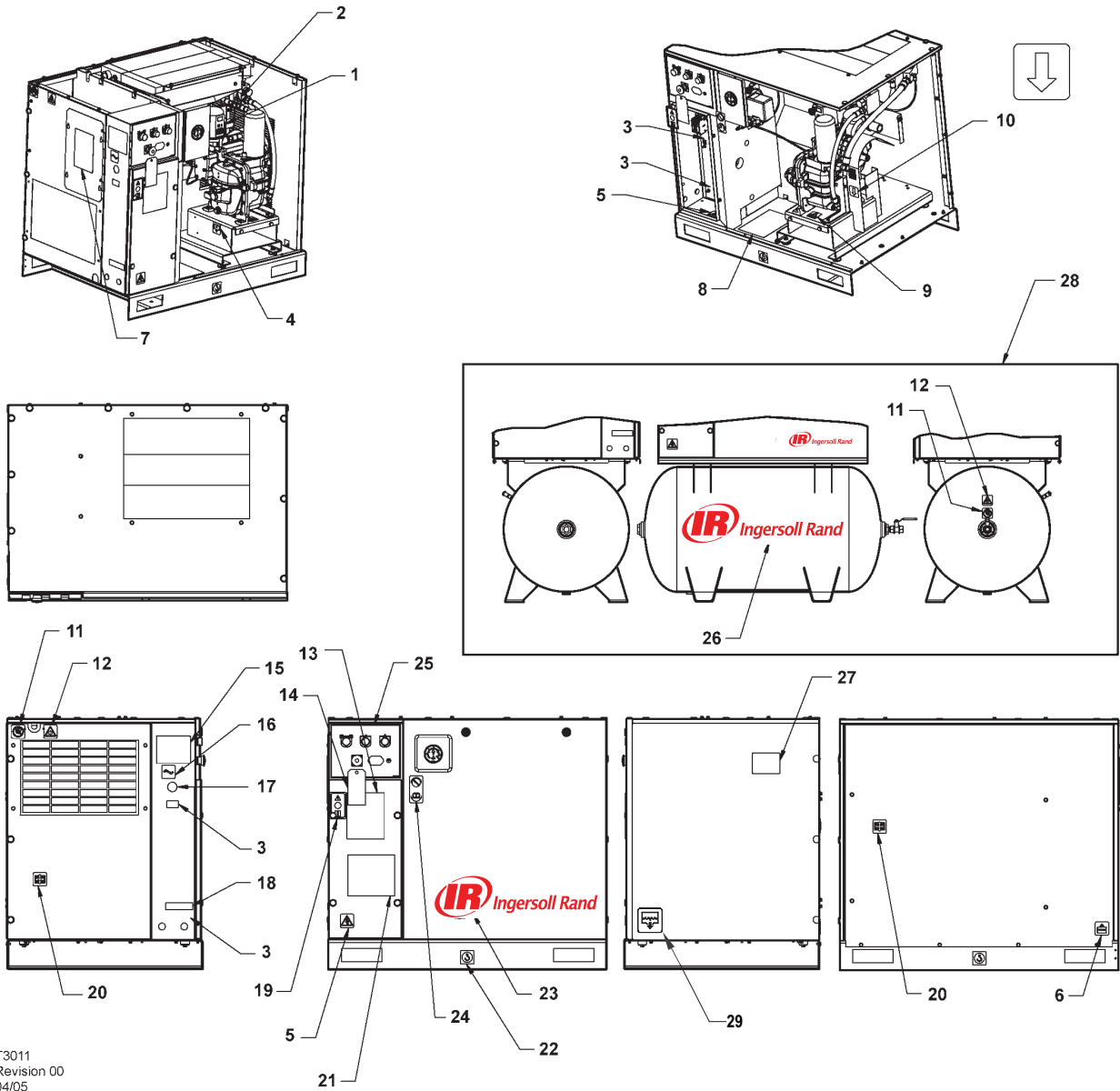

T3011
Revision 00
04/05

Item	ccn	Qty.	Description	Item	ccn	Qty.	Description
1	93166502	1	Decal, replacement element	12	92867498	1	Decal, notice air discharge Base mount only
2	92867530	1	Decal, warning hot surface	13	22547145	1	Decal, total air system Dryer packages only
3		3	Decal, voltage	14	22459200	1	Tag, rotation
4	93166460	1	Decal, coolant drain	15	SPEC	1	Specifications, compressor package
5	92960593	2	Decal, warning hazardous voltage	16	93166486	1	Decal, power inlet
6	93166478	1	Decal, condensate drain	17	22141311	1	Decal, place to cover hole
7	22530331	1	Decal, dryer bypass instruction	18	22604276	1	Decal, multiple wiring circuit Dryer packages only
8	23353196	1	Decal, maintenance parts	19	93493641	1	Decal, start up warning
9	92930585	1	Decal, pressurized vessel				
10	93165983	1	Decal, rotation direction				
11	92867407	2	Decal, do not inhale				

Contd....

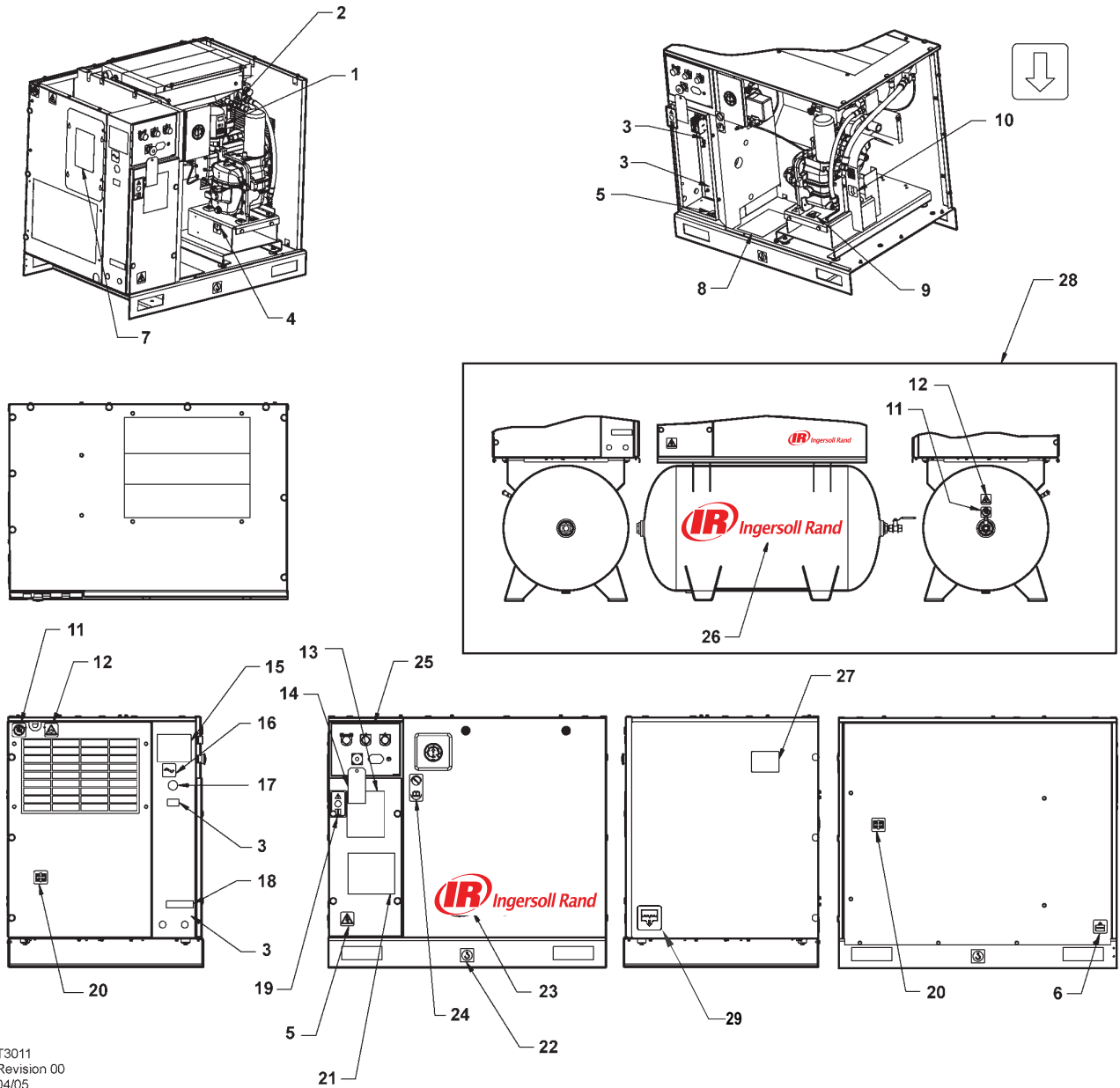

T3011
Revision 00
04/05

Item	ccn	Qty.	Description	Item	ccn	Qty.	Description
20	93165959	1	Decal, use guards when running	25	22417109	1	Decal, facia Rectangular hourmeter
21		1	Decal, wiring schematic diagram	22529291	1	Decal, facia Round hourmeter	
22	93171262	1	Decal, lift here both sides Base mount only	26	23038474	1	Decal, Ingersoll Rand logo
23	22913032	1	Decal, Ingersoll Rand logo Base mount only	27	22454060	1	Decal, belt
	22435713	1	Decal, Ingersoll Rand logo Receiver mount only	28			Tank mount option
24	92930668	1	Decal, no maintenance before referring to manual	29	54618681	1	Decal, condensate drain

SAFETY**DANGER**

Hazard that **WILL** cause **DEATH, SEVERE INJURY** or substantial property damage if ignored. Instructions must be followed precisely to avoid injury or death.

WARNING

Hazard that **CAN** cause **DEATH, SEVERE INJURY** or substantial property damage if ignored. Instructions which must be followed precisely to avoid injury or death.

CAUTION

Cautions call attention to instructions which must be followed precisely to avoid damaging the product, process or its surroundings.

NOTES

Notes are used for supplementary information.

BREATHING AIR PRECAUTION

Ingersoll Rand air compressors are not designed, intended or approved for breathing air. Compressed air should not be used for breathing air applications unless treated in accordance with all applicable codes and regulations.

GENERAL INFORMATION

Ensure that the operator reads and understands the decals and consults the manuals before maintenance or operation.

Ensure that the Operation and Maintenance manual is not removed permanently from the machine.

Ensure that maintenance personnel are adequately trained, competent and have read the Maintenance Manuals.

Do not point air nozzles or sprayers toward anyone.

Compressed air and electricity can be dangerous. Before undertaking any work on the compressor, ensure that the electrical supply has been isolated and the compressor has been relieved of all pressure.

Wear eye protection when operating or servicing compressor.

All persons positioned near to operating machinery should be equipped with hearing protection and given instructions on its use in accordance with workplace safety legislation.

Make sure that all protective covers are in place and that the canopy/doors are closed during operation.

The specification of this machine is such that the machine is not suitable for use in flammable gas risk areas.

Installation of this compressor must be in accordance with recognised electrical codes and any local Health and Safety Codes.

The use of plastic bowls on line filters can be hazardous. Their safety can be affected by either synthetic lubricants, or the additives used in mineral oils. **Ingersoll Rand** recommends that only filters with metal bowls should be used on a pressurised system.

COMPRESSED AIR

Compressed air can be dangerous if incorrectly handled. Before doing any work on the unit, ensure that all pressure is vented from the system and that the machine cannot be started accidentally.

WARNING

Imposing a normal or emergency stop on the compressor will only relieve pressure upstream of the minimum pressure valve on top of the separator tank. If maintenance work is required downstream of this valve, ensure that all pressure is relieved at the process vent point external to the compressor.

Ensure that the machine is operating at the rated pressure and that the rated pressure is known to all relevant personnel.

All air pressure equipment installed in or connected to the machine must have safe working pressure ratings of at least the machine rated pressure.

If more than one compressor is connected to one common downstream plant, effective isolation valves must be fitted and controlled by work procedures, so that one machine cannot accidentally be pressurised / over pressurised by another.

Compressed air must not be used for a direct feed to any form of breathing apparatus or mask.

The discharged air contains a very small percentage of compressor lubricant and care should be taken to ensure that downstream equipment is compatible.

If the discharged air is to be ultimately released into a confined space, adequate ventilation must be provided.

When using compressed air always use appropriate personal protective equipment.

All pressure containing parts, especially flexible hoses and their couplings, must be regularly inspected, be free from defects and be replaced according to the Manual instructions.

Compressed air can be dangerous if incorrectly handled. Before doing any work on the unit, ensure that all pressure is vented from the system and that the machine cannot be started accidentally.

Avoid bodily contact with compressed air.

All safety valves located in the separator tank must be checked periodically for correct operation.

Do not over-pressurize the receiver tank or similar vessels beyond design limits.

Do not use a receiver tank or similar vessels that fail to meet the design requirements of the compressor. Contact your distributor for assistance.

Do not drill into, weld or otherwise alter the receiver tank or similar vessels.

Before servicing the unit, vent pressure before removing the power to ensure that the gauge reads zero pressure.

MATERIALS

The following substances are used in the manufacture of this machine and may be hazardous to health if used incorrectly:

- preservative grease
- rust preventative
- compressor coolant

AVOID INGESTION, SKIN CONTACT AND INHALATION OF FUMES

TRANSPORT

When loading or transporting machines ensure that the specified lifting and tie down points are used.

Lifting equipment must be properly rated for the weight of the compressor.

Do not work on or walk under the compressor while it is suspended.

ELECTRICAL

Keep all parts of the body and any hand-held tools or other conductive objects, away from exposed live parts of the compressor electrical system. Maintain dry footing, stand on insulating surfaces and do not contact any other portion of the compressor when making adjustments or repairs to exposed live parts of the compressor electrical system.

WARNING

Any electrical connections or adjustments should only be made by a suitably qualified electrician

Close and lock all access doors when the compressor is left unattended.

Do not use extinguishers intended for Class A or Class B fires on electrical fires. Use only extinguishers suitable for class BC or class ABC fires.

Attempt repairs only in clean, dry, well lighted and ventilated areas.

Connect the compressor only to electrical systems that are compatible with its electrical characteristics and that are within it's rated capacity.

CONDENSATE DISPOSAL

As waste water regulations vary by country and region it is the responsibility of the user to establish the limitations and regulations in their particular area. **Ingersoll Rand** and its associated distributors are happy to advise and assist in these matters.

For further information, consult Material Data Sheets for ULTRA.

The above information contains data supplied in support of United Kingdom *Control of Substances Hazardous to Health (C.O.S.H.H.)* regulations.

GENERAL INFORMATION

PIPING AND INSTRUMENTATION

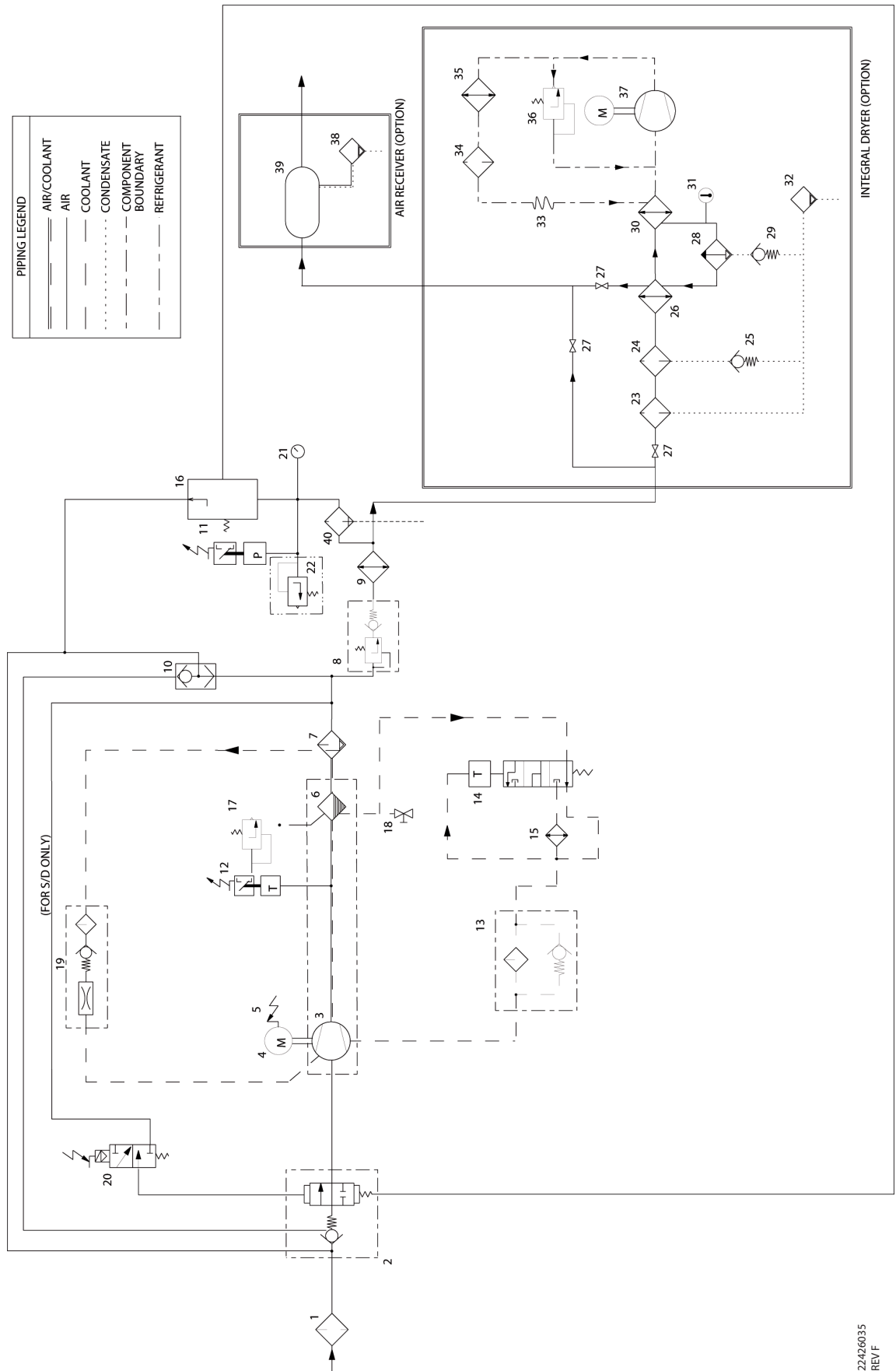

KEY

1	Filter, air	21	Gauge, pressure
2	Valve, air inlet	22	Valve, relief (sirc)
3	Air end assembly	23	Filter, general purpose air
4	Motor	24	Filter, high efficiency air
5	Relay, motor overload	25	Valve, check
6	Tank, separator - coarse	26	Recuperator
7	Tank, separator - fine	27	Valve, isolation (option)
8	Valve, minimum pressure	28	Moisture separator
9	Aftercooler	29	Valve, check
10	Valve, blowdown	30	Evaporator
11	Switch, pressure	31	Indicator, dew point
12	Switch, temperature	32	Valve, condensate
13	Filter, coolant	33	Tube, capillary
14	Thermostat	34	Filter drier, refrigerant
15	Cooler, oil	35	Condenser
16	Valve, pilot	36	Valve, hot gas bypass
17	Valve, relief	37	Compressor, refrigerant
18	Valve, drain	38	Valve, auto drain
19	Screen, scavenge	39	Receiver, air
20	Valve, solenoid	40	Filter

SCHEMATIC, ELECTRICAL UP6 5–15HP FV 3PH 60Hz DOL – U.S.A.

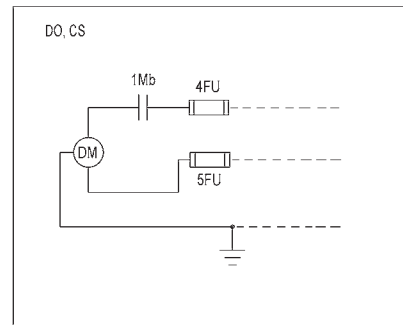
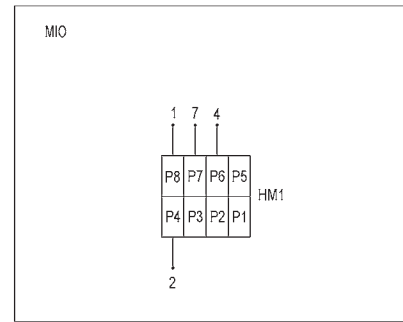
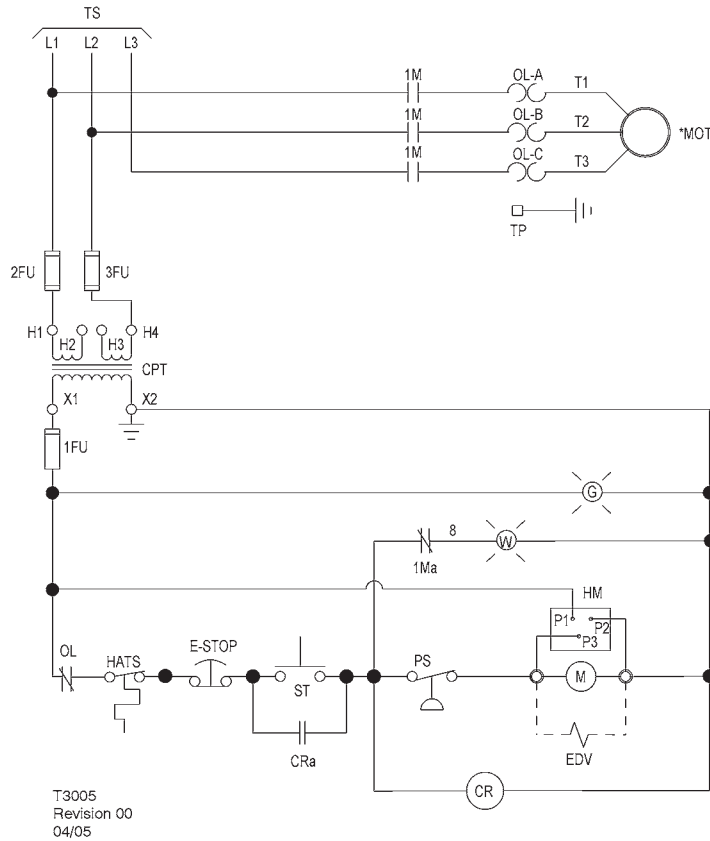

KEY

1FU,	Fuse control circuit	HATS	Switch, high air temperature
2FU, 3FU		M	Coil motor starter
4FU, 5FU	Fuse	MIO	Indicator, maintenance option (Instead of standard hourmeter)
1Ma	Contact, auxiliary starter	MOT	Motor
1Mb	Contact, auxiliary starter	OL	Overload, motor starter
CPT	Transformer, control 120/1/50–60 See transformer nameplate for wiring connection requirements	PS	Switch, pressure
CR	Relay, control	ST	Push button, start
CRa	Contact, control relay	TP	Terminal points
CS	Customer supplied 115v / 1 / 60hz	TS	To supply
DO	Dryer option	W	Standby light
DM	Motor, dryer		
EDV	Valve, electric drain 120/1/50–60		
E-STOP	Button, emergency stop		
G	Power on light		
HM	Hourmeter		
HM1	Indicator, maintenance		

NOTES

1. (*) Furnished, mounted and wired outside of control panel, if required by order.
2. Circuit shown in normal position de-energized.
3. All wiring to be marked in accordance with this schematic.
4. All wiring to be in accordance with NEC.

SCHEMATIC, ELECTRICAL UP6 5-15HP SD 3PH 60Hz

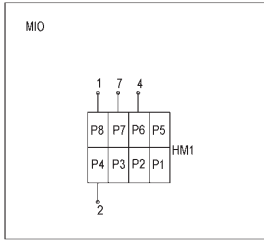
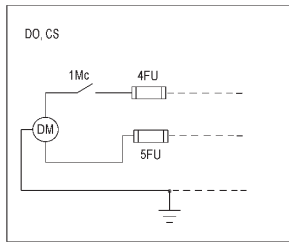
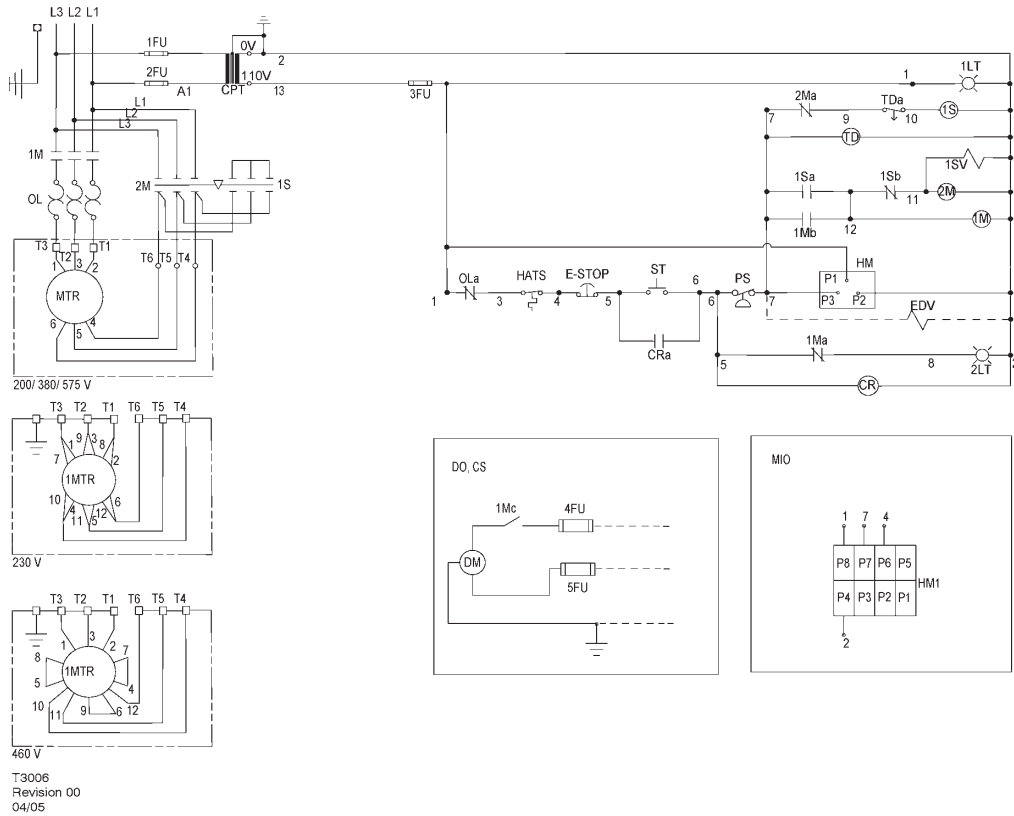

KEY

1FU, 2FU	Fuse, primary	HATS	Switch, high air temperature
3FU	Fuse, secondary	HM	Hourmeter
4FU, 5FU	Fuse, dryer	HM1	Indicator, maintenance
1LT	Light, power on indicator (green)	MIO	Indicator, maintenance option (Instead of standard hourmeter)
2LT	Light, auto restart indicator (white)	MTR	Motor, compressor
1M	Contactor, main	OL	Overload, main motor
1Ma, b, c	Contacts, auxiliary. Main contactor	OLa	Contact, main motor overload
2M	Contactor, delta	PS	Switch, pressure
2Ma, b	Contacts, auxiliary. Delta contactor	ST	Push button, start
1S	Contactor, star	TD	Relay, delta starting (10sec)
1Sa, b	Contacts, auxiliary. Star contactor	TDc	Relay, delay off, contact
1SV	Valve, solenoid (nc)		
CPT	Transformer, control		
CR	Relay, control		
CRa	Contact, control relay		
CS	Customer supplied 115v / 1 / 60hz		
DM	Motor, dryer		
DO	Dryer option		
EDV	Valve, electric drain (optional)		
E-STOP	Switch, emergency stop		

NOTES

1. (*) Furnished, mounted and wired outside of control panel, if required by order.
2. Circuit shown in normal position de-energized.
3. All wiring to be marked in accordance with this schematic.
4. All wiring to be in accordance with NEC.

SCHEMATIC, ELECTRICAL UP6 5-15HP FV 1PH 60Hz - U.S.A.

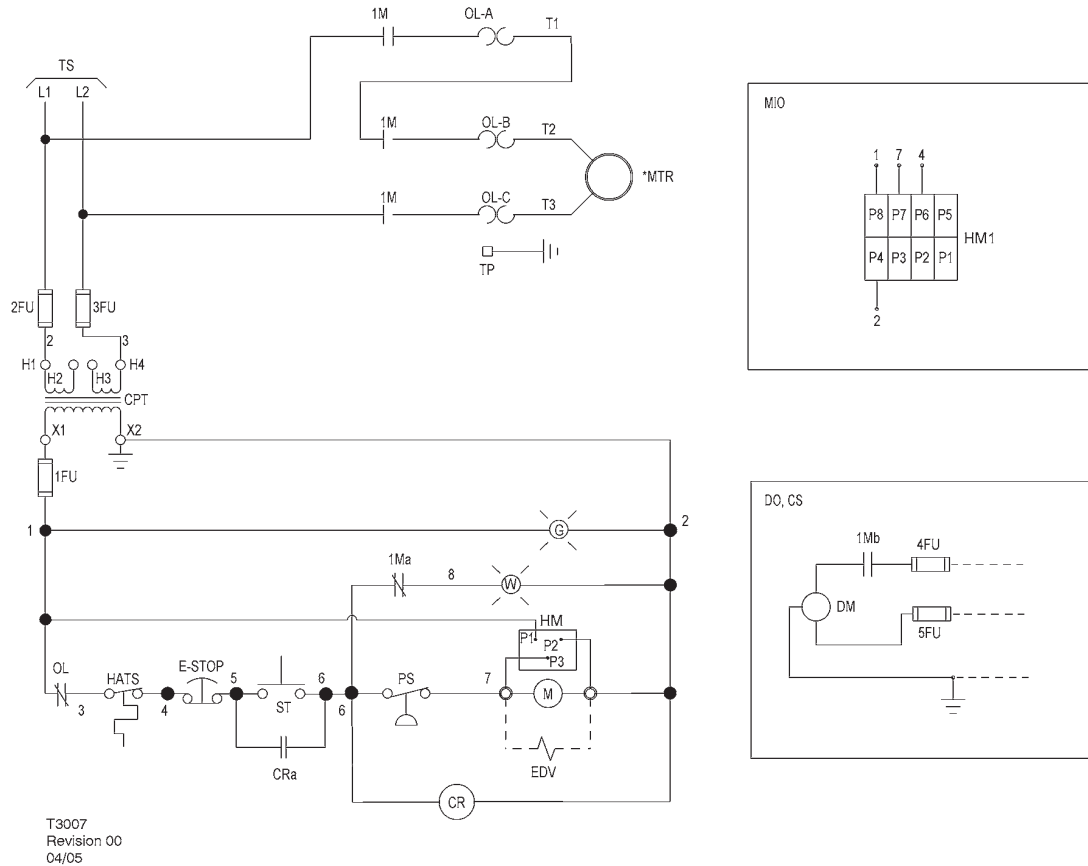

T3007
Revision 00
04/05

KEY

1FU, 2FU, 3FU	Fuse control circuit	M	Coil motor starter
4FU, 5FU	Fuse, dryer	MIO	Indicator, maintenance option (Instead of standard hourmeter)
1Ma	Contact, auxiliary starter	MTR	Motor, compressor
1Mb	Contact, auxiliary starter	OL	Overload, motor starter
CPT	Transformer, control 120/1/50-60 see Transformer nameplate for wiring Connection requirements	PS	Switch, pressure
CR	Relay, control	ST	Push button, start
CRa	Contact, control relay	TP	Terminal points
CS	Customer supplied 115v / 1 / 60hz	TS	To supply
DM	Motor, dryer	W	Standby light
DO	Dryer option		
EDV	Valve, electric drain		
E-STOP	Switch, emergency stop		
G	Power on light		
HM	Hourmeter		
HM1	Indicator, maintenance		

NOTES

1. (*) Furnished, mounted and wired outside of control panel, if required by order.
2. Circuit shown in normal position de-energized.
3. All wiring to be marked in accordance with this schematic.
4. All wiring to be in accordance with NEC.

SCHEMATIC, ELECTRICAL UP5 5–15HP FV 3PH 50Hz DOL

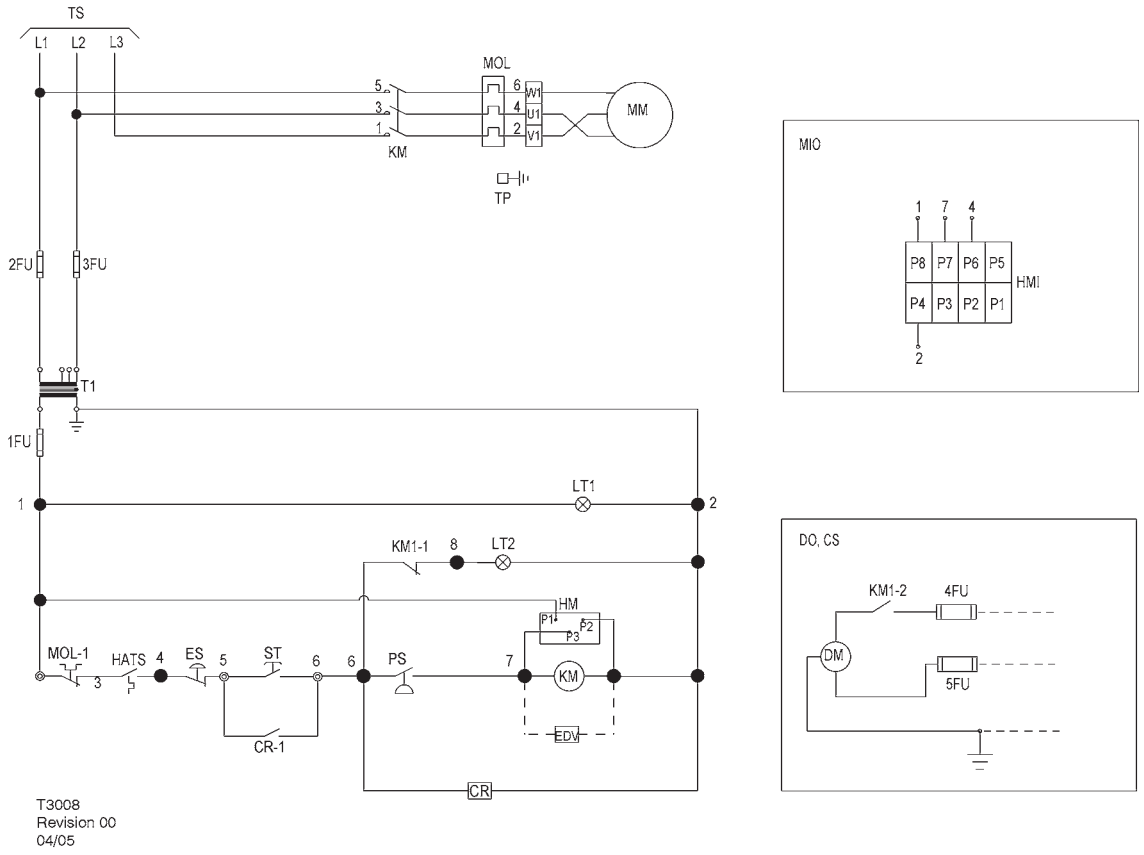

KEY

1FU	Fuse, secondary	MIO	Indicator, maintenance option (Instead of standard hourmeter)
2FU, 3FU	Fuse, primary	MM	Motor, compressor
4FU, 5FU	Fuse, dryer	MOL	Overload, main motor
CR	Relay, control	MOL-1	Contact, main motor overload
CS	Customer supplied 230v / 1 / 50hz	PS	Switch, pressure
DM	Motor, dryer	ST	Push button, start
DO	Dryer option	T1	Transformer, control
EDV	Valve, electric drain	TP	Terminal points
ES	Switch, emergency stop	TS	To supply
HATS	Switch, high air temperature		
HM	Hourmeter		
HM1	Indicator, maintenance		
KM	Contact, main		
KM-1,2	Contacts, auxiliary. Main contactor		
LT1	Light, power on indicator (green)		
LT2	Light, auto restart indicator (white)		

- NOTES**
- (*) Furnished, mounted and wired outside of control panel, if required by order.
 - Circuit shown in normal position de-energized.
 - All wiring to be marked in accordance with this schematic.
 - All wiring to be in accordance with NEC.

SCHEMATIC, ELECTRICAL UP5 5–15HP SD 3PH 50Hz

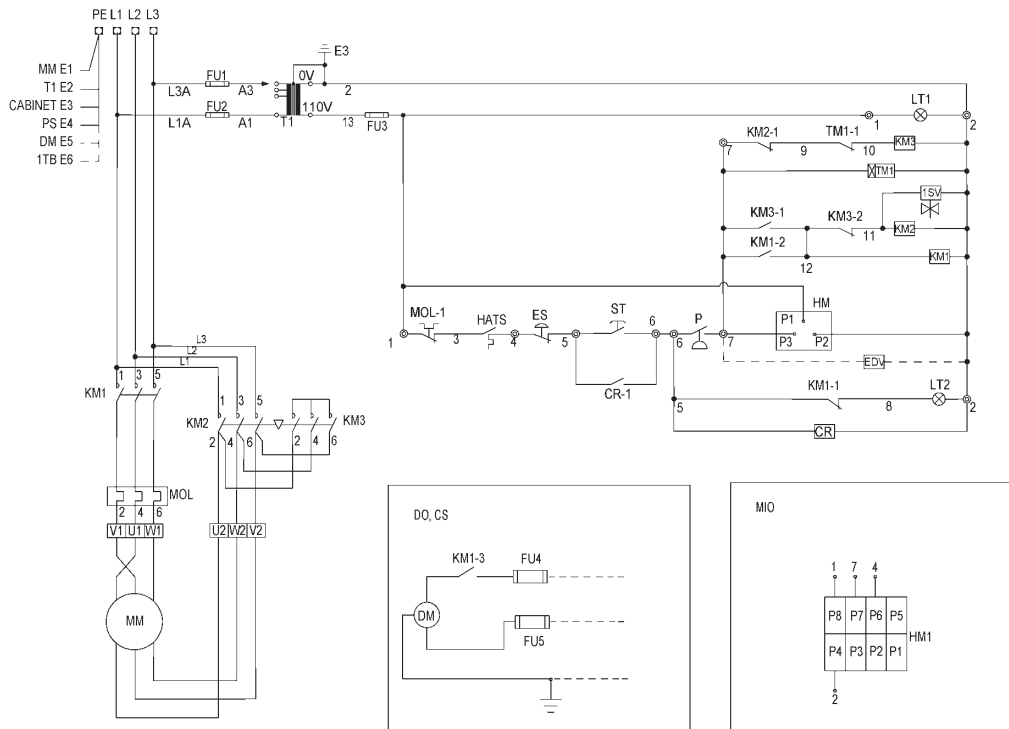

T3009
Revision 00
04/05

KEY

1SV	Valve, solenoid (nc)	KM2-1,2	Contacts, auxiliary. Delta contactor
CR	Relay, control	KM3	Contact, star
CR-1	Contact, control relay	KM3-1,2	Contacts, auxiliary. Star contactor
CS	Customer supplied 230v / 1 / 50hz	LT1	Light, power on indicator (green)
DM	Motor, dryer	LT2	Light, auto restart indicator (white)
DO	Dryer option	MIO	Indicator, maintenance option (Instead of standard hourmeter)
EDV	Valve, electric drain	MOL	Overload, main motor
HATS	Switch, high air temperature	MOL-1	Contact, main motor overload
HM	Hourmeter	ST	Push button, start
HM1	Indicator, maintenance	T1	Transformer, control
MM	Motor, compressor	TM1	Relay, delta starting (10sec)
P	Switch, pressure	TM1-1	Relay, delay off, contact
ES	Switch, emergency stop		
FU1, FU2	Fuse, primary		
FU3	Fuse, secondary		
FU4, FU5	Fuse, dryer		
KM1	Contact, main		
KM-1,2,3	Contacts, auxiliary. Main contactor		
KM2	Contact, delta		

NOTES

- (*) Furnished, mounted and wired outside of control panel, if required by order.
- Circuit shown in normal position de-energized.
- All wiring to be marked in accordance with this schematic.
- All wiring to be in accordance with NEC.

INSTALLATION/HANDLING

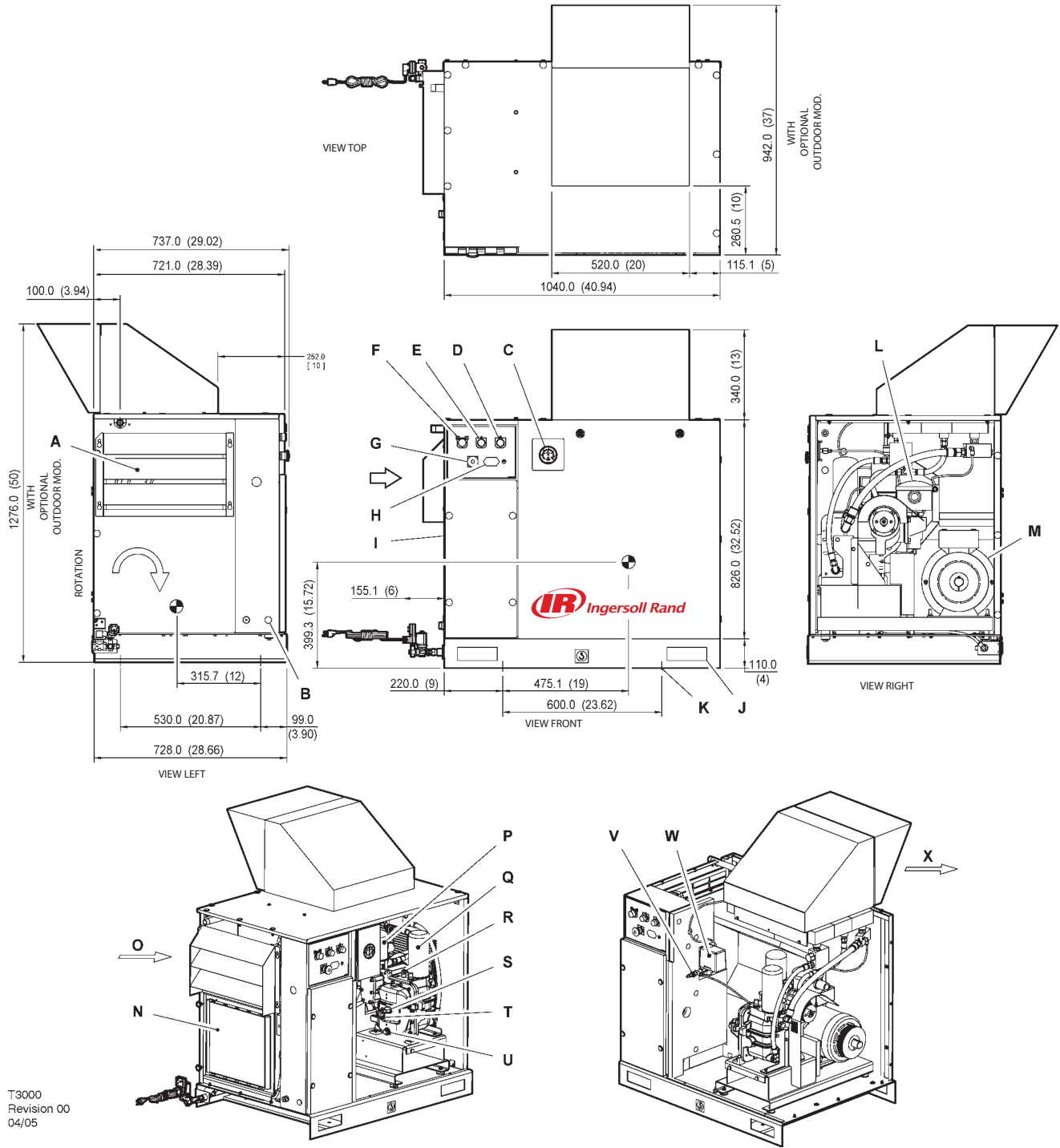

T3000
Revision 00
04/05

KEY

A	Package pre-filler	M	Motor
B	Hole, incoming power supply conduit	N	Integrated dryer (Optional)
C	Gauge, pressure	O	Compressor and cooling air intake
D	Yellow stand-by light	P	Filter, coolant
E	Green power-on light	Q	Cartridge, coolant separator
F	Green start push button	R	Valve, aircend relief
G	Emergency stop button	S	Plug, coolant filler
H	Hourmeter	T	Sight-glass
I	Starter box	U	Plug, coolant drain
J	Lifting points	V	Valve, pilot
K	Mounting holes (4 x 14.0mm [0.550"] diameter)	W	Switch, pressure
L	Filter, air inlet	X	Cooling air exhaust

NOTES

1. Foundation or floor must be level and support all mounting bolt locations equally. If necessary, shim or grout the fourth bolt location.
2. Foundation bolts should protect thru nuts a minimum of 13mm (0.50") to allow for levelling.
3. Allow a minimum clearance of 1100mm (42") on the front and 920mm (36") on the top, left right and rear of the package for proper air circulation and serviceability.
4. Approximate package weight: 298kg (655lbs).
5. External piping shall not exert any unresolved moments or forces on the unit. Use pipe size as large or larger at discharge connection.
6. There should be no plastic or pvc piping attached to this unit or used for any lines downstream.
7. Do not pipe into a common header with a reciprocating compressor, unless the reciprocating compressor utilizes a discharge pulsation damper.
8. Sizing of electrical components not supplied by **Ingersoll Rand** is the responsibility of the customer and should be done in accordance with the information on the compressor data plate and national and local electrical codes.

NOTE

All dimensions are in millimetres (inches) unless otherwise stated.

Ensure that the correct fork lift truck slots or marked lifting points are used whenever the machine is lifted or transported.

UNPACKING

The compressor will normally be delivered with a polythene cover. If a knife has to be used to remove this cover ensure that the exterior paintwork of the compressor is not damaged.

Ensure that all transport and packing materials are discarded in a manner prescribed by local codes.

**UP-SERIES
TANK MOUNTED (80 GAL)**

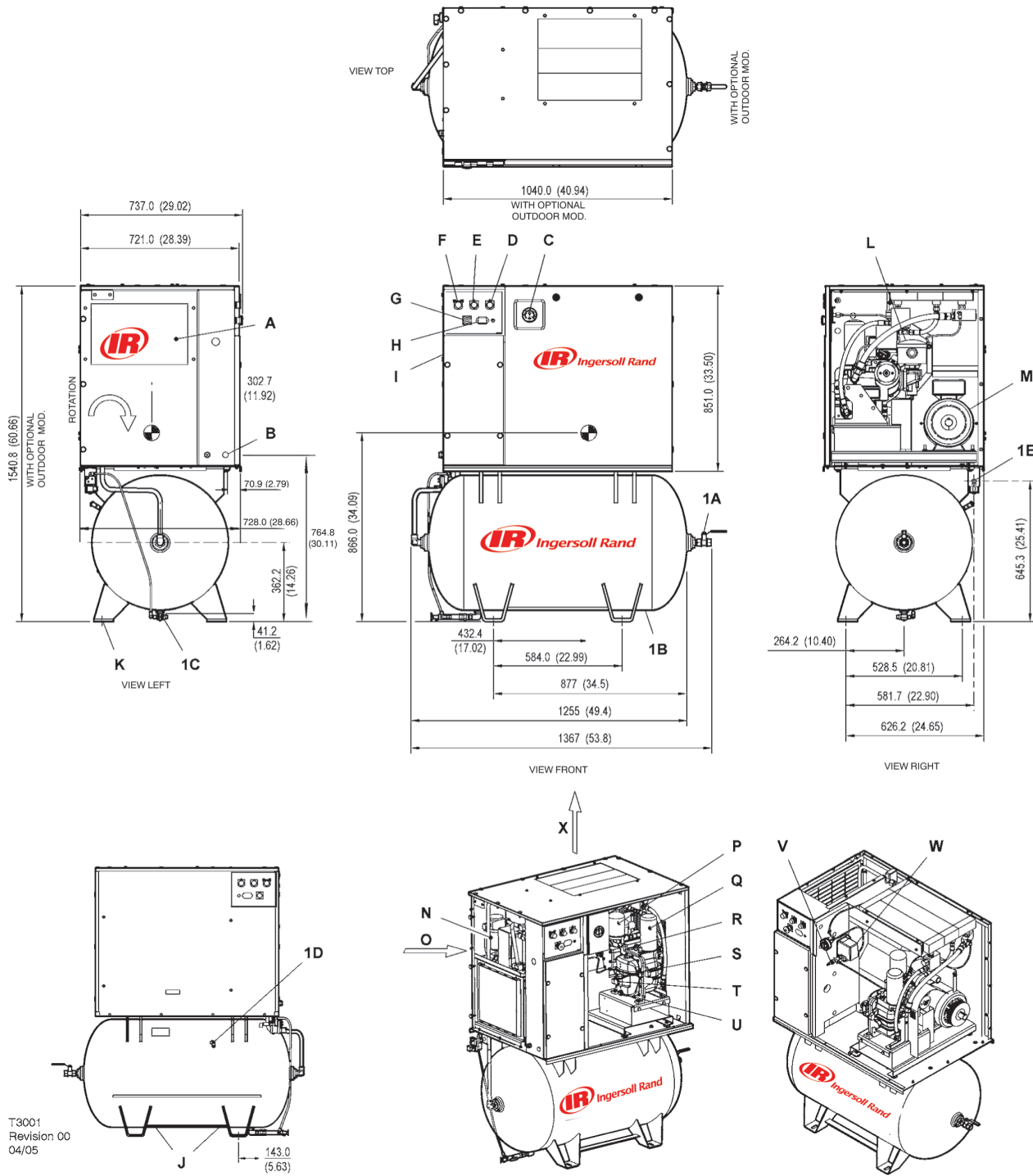

T3001
Revision 00
04/05

KEY

A	Package pre-filler	P	Filter, coolant
B	Hole, incoming power supply conduit	Q	Cartridge, coolant separator
C	Gauge, pressure	R	Valve, aircend relief
D	Yellow stand-by light	S	Plug, coolant filler
E	Green power-on light	T	Sight-glass
F	Green start push button	U	Plug, coolant drain
G	Emergency stop button	V	Valve, pilot
H	Hourmeter	W	Switch, pressure
I	Starter box	X	Cooling air exhaust
J	Lifting points	1A	Valve, ball 0.75" N.P.T.
K	Mounting holes (4 x 17.5mm [0.68"] x 44.5mm [1.75"] slots)	1B	Air receiver (Ø 620.0mm x 1168.4mm LG) (Ø 24.40" x 46.00" LG)
L	Filter, air inlet	1C	Location for manual receiver drain
M	Motor	1D	Valve, receiver relief
N	Integrated dryer (Optional)	1E	0.25" discharge port for optional electric drain valve
O	Compressor and cooling air intake		

NOTES

1. Foundation or floor must be level and support all mounting bolt locations equally. If necessary, shim or grout the fourth bolt location.
2. Foundation bolts should protect thru nuts a minimum of 13mm (0.50") to allow for levelling.
3. Allow a minimum clearance of 1100mm (42") on the front and 920mm (36") on the top, left right and rear of the package for proper air circulation and serviceability.
4. Approximate package weight: 420kg (925lbs).
5. External piping shall not exert any unresolved moments or forces on the unit. Use pipe size as large or larger at discharge connection.
6. There should be no plastic or pvc piping attached to this unit or used for any lines downstream.
7. Do not pipe into a common header with a reciprocating compressor, unless the reciprocating compressor utilizes a discharge pulsation damper.
8. Sizing of electrical components not supplied by **Ingersoll Rand** is the responsibility of the customer and should be done in accordance with the information on the compressor data plate and national and local electrical codes.

NOTE

All dimensions are in millimetres (inches) unless otherwise stated.

Ensure that the correct fork lift truck slots or marked lifting points are used whenever the machine is lifted or transported.

UNPACKING

The compressor will normally be delivered with a polythene cover. If a knife has to be used to remove this cover ensure that the exterior paintwork of the compressor is not damaged.

Ensure that all transport and packing materials are discarded in a manner prescribed by local codes.

**UP-SERIES
TANK MOUNTED (120 GAL)**

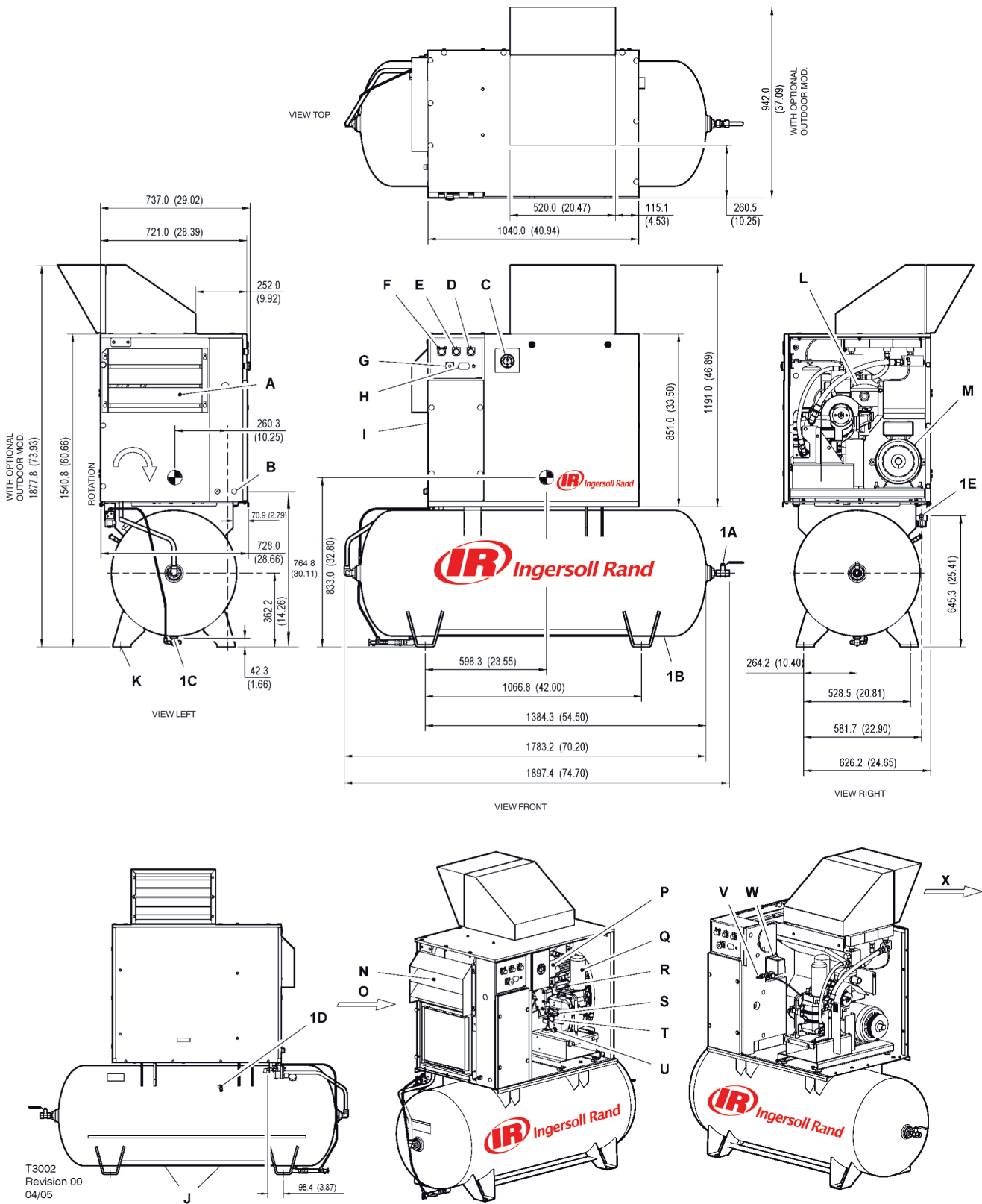

KEY

A	Package pre-filler	P	Filter, coolant
B	Hole, incoming power supply conduit	Q	Cartridge, coolant separator
C	Gauge, pressure	R	Valve, aircend relief
D	Yellow stand-by light	S	Plug, coolant filler
E	Green power-on light	T	Sight-glass
F	Green start push button	U	Plug, coolant drain
G	Emergency stop button	V	Valve, pilot
H	Hourmeter	W	Switch, pressure
I	Starter box	X	Cooling air exhaust
J	Lifting points	1A	Valve, ball 0.75" N.P.T.
K	Mounting holes (4 x 17.5mm [0.68"] x 44.5mm [1.75"] slots)	1B	Air receiver (Ø 618.0mm x 1701.0mm LG) (Ø 24.33" x 67.00" LG)
L	Filter, air inlet	1C	Location for manual receiver drain
M	Motor	1D	Valve, receiver relief
N	Integrated dryer (Optional)	1E	0.25" discharge port for optional electric drain valve
O	Compressor and cooling air intake		

NOTES

1. Foundation or floor must be level and support all mounting bolt locations equally. If necessary, shim or grout the fourth bolt location.
2. Foundation bolts should protect thru nuts a minimum of 13mm (0.50") to allow for levelling.
3. Allow a minimum clearance of 1100mm (42") on the front and 920mm (36") on the top, left right and rear of the package for proper air circulation and serviceability.
4. Approximate package weight: 430kg (946lbs).
5. External piping shall not exert any unresolved moments or forces on the unit. Use pipe size as large or larger at discharge connection.
6. There should be no plastic or pvc piping attached to this unit or used for any lines downstream.
7. Do not pipe into a common header with a reciprocating compressor, unless the reciprocating compressor utilizes a discharge pulsation damper.
8. Sizing of electrical components not supplied by **Ingersoll Rand** is the responsibility of the customer and should be done in accordance with the information on the compressor data plate and national and local electrical codes.

NOTE

All dimensions are in millimetres (inches) unless otherwise stated.

Ensure that the correct fork lift truck slots or marked lifting points are used whenever the machine is lifted or transported.

UNPACKING

The compressor will normally be delivered with a polythene cover. If a knife has to be used to remove this cover ensure that the exterior paintwork of the compressor is not damaged.

Ensure that all transport and packing materials are discarded in a manner prescribed by local codes.

**UP-SERIES
TANK MOUNTED (272 LITRES)**

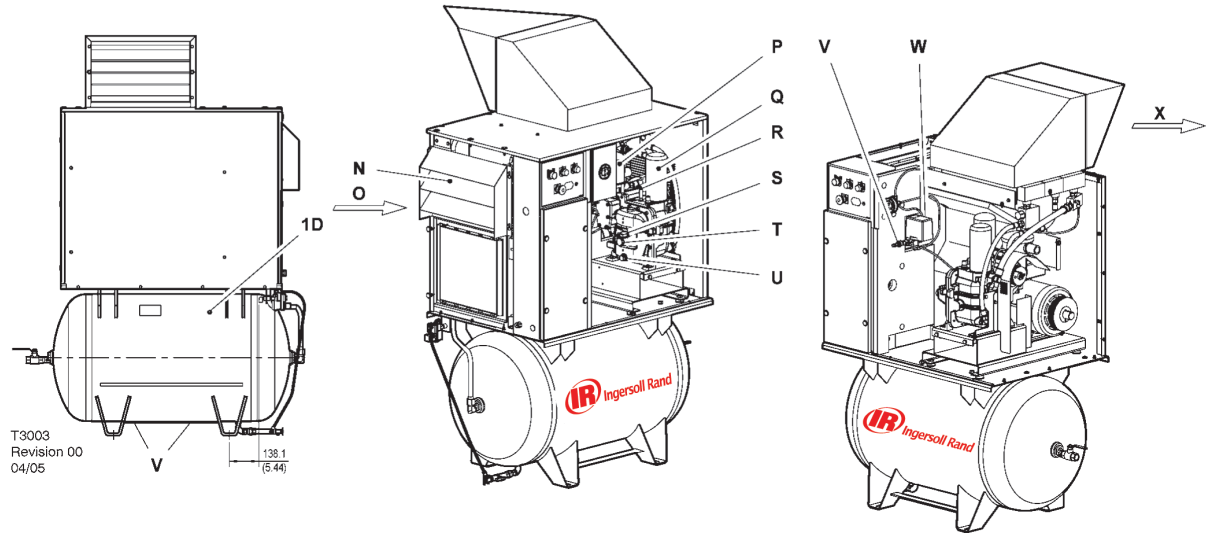
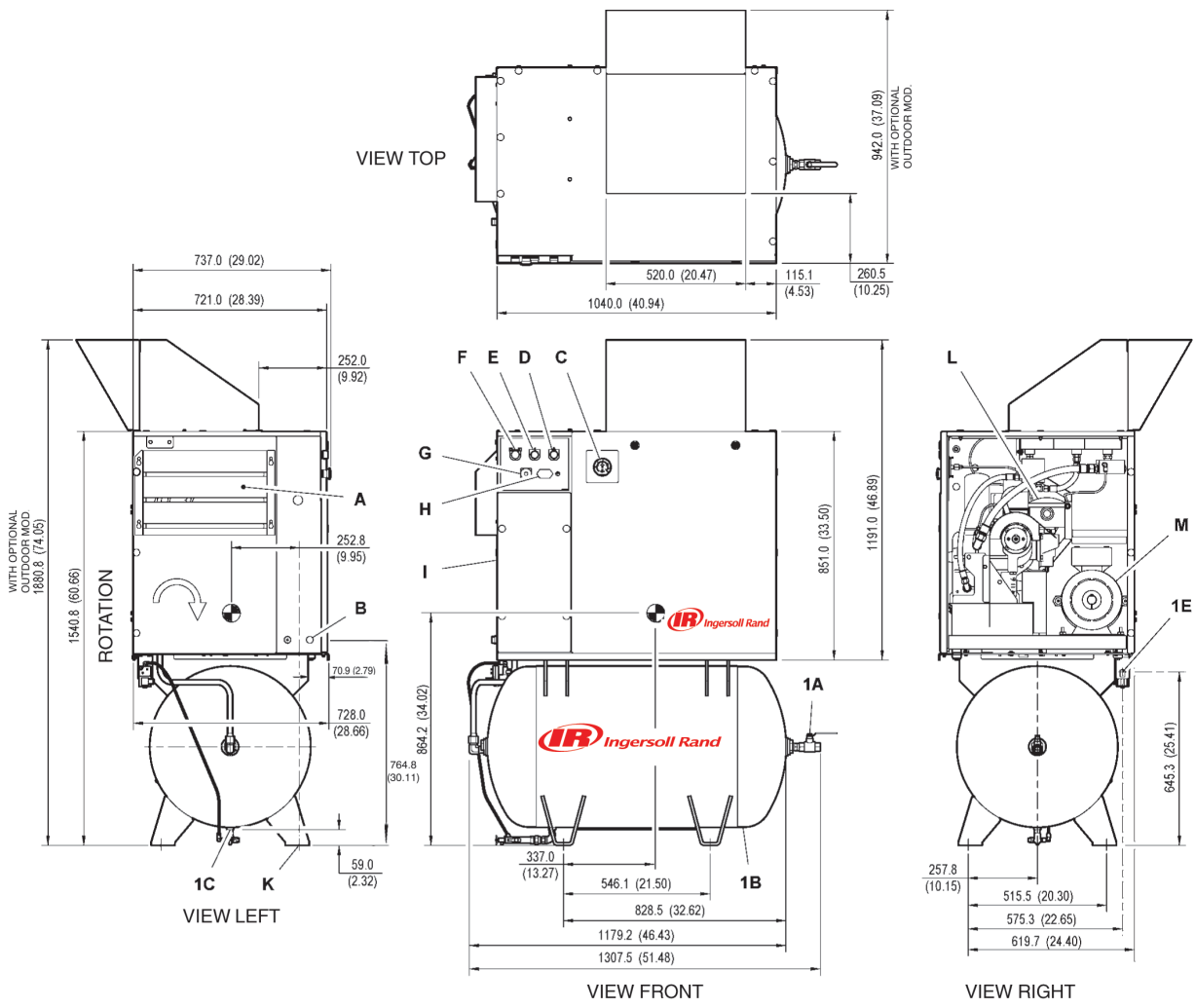

KEY

A	Package pre-filler	P	Filter, coolant
B	Hole, incoming power supply conduit	Q	Cartridge, coolant separator
C	Gauge, pressure	R	Valve, aircend relief
D	Yellow stand-by light	S	Plug, coolant filler
E	Green power-on light	T	Sight-glass
F	Green start push button	U	Plug, coolant drain
G	Emergency stop button	V	Valve, pilot
H	Hourmeter	W	Switch, pressure
I	Starter box	X	Cooling air exhaust
J	Lifting points	1A	Valve, ball 0.75" N.P.T.
K	Mounting holes (4 x 17.5mm [0.68"] x 44.5mm [1.75"] slots)	1B	Air receiver (Ø 600.0mm x 1111.0mm LG) (Ø 23.62" x 43.74" LG)
L	Filter, air inlet	1C	Location for manual receiver drain
M	Motor	1D	Valve, receiver relief
N	Integrated dryer (Optional)	1E	0.25" discharge port for optional electric drain valve
O	Compressor and cooling air intake		

NOTES

1. Foundation or floor must be level and support all mounting bolt locations equally. If necessary, shim or grout the fourth bolt location.
2. Foundation bolts should protect thru nuts a minimum of 13mm (0.50") to allow for levelling.
3. Allow a minimum clearance of 1100mm (42") on the front and 920mm (36") on the top, left right and rear of the package for proper air circulation and serviceability.
4. Approximate package weight: 400kg (880lbs).
5. External piping shall not exert any unresolved moments or forces on the unit. Use pipe size as large or larger at discharge connection.
6. There should be no plastic or pvc piping attached to this unit or used for any lines downstream.
7. Do not pipe into a common header with a reciprocating compressor, unless the reciprocating compressor utilizes a discharge pulsation damper.
8. Sizing of electrical components not supplied by **Ingersoll Rand** is the responsibility of the customer and should be done in accordance with the information on the compressor data plate and national and local electrical codes.

NOTE

All dimensions are in millimetres (inches) unless otherwise stated.

Ensure that the correct fork lift truck slots or marked lifting points are used whenever the machine is lifted or transported.

UNPACKING

The compressor will normally be delivered with a polythene cover. If a knife has to be used to remove this cover ensure that the exterior paintwork of the compressor is not damaged.

Ensure that all transport and packing materials are discarded in a manner prescribed by local codes.

**UP-SERIES
TANK MOUNTED (500 LITRES)**

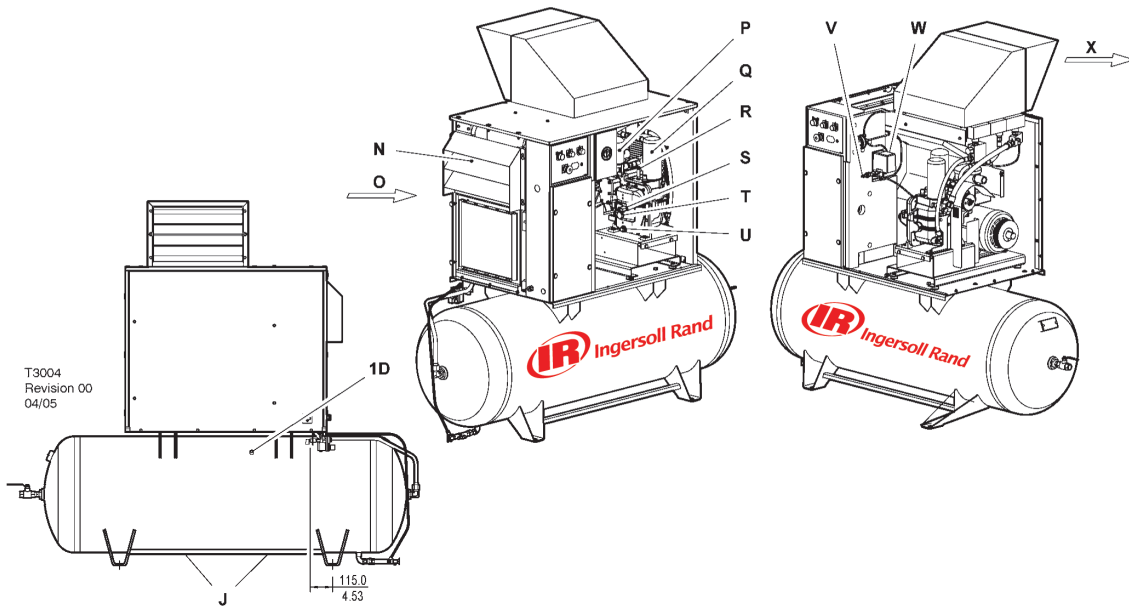
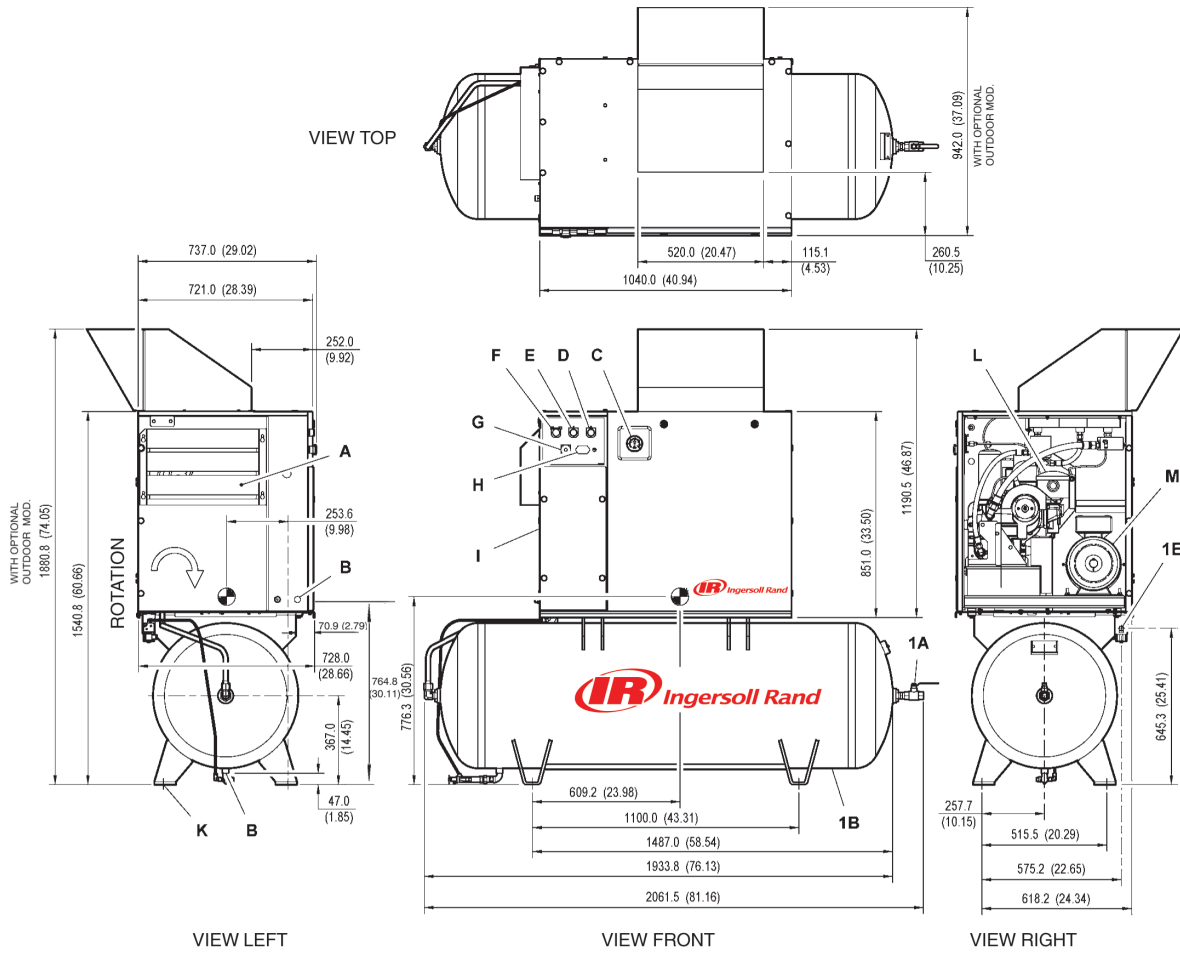

KEY

A	Package pre-filler	P	Filter, coolant
B	Hole, incoming power supply conduit	Q	Cartridge, coolant separator
C	Gauge, pressure	R	Valve, airtight relief
D	Yellow stand-by light	S	Plug, coolant filler
E	Green power-on light	T	Sight-glass
F	Green start push button	U	Plug, coolant drain
G	Emergency stop button	V	Valve, pilot
H	Hourmeter	W	Switch, pressure
I	Starter box	X	Cooling air exhaust
J	Lifting points	1A	Valve, ball 0.75" N.P.T.
K	Mounting holes (4 x 17.5mm [0.68"] x 44.5mm [1.75"] slots)	1B	Air receiver (Ø 610.0mm x 1866.0mm LG) (Ø 24.02" x 73.46" LG)
L	Filter, air inlet	1C	Location for manual receiver drain
M	Motor	1D	Valve, receiver relief
N	Integrated dryer (Optional)	1E	0.25" discharge port for optional electric drain valve
O	Compressor and cooling air intake		

NOTES

1. Foundation or floor must be level and support all mounting bolt locations equally. If necessary, shim or grout the fourth bolt location.
2. Foundation bolts should protect thru nuts a minimum of 13mm (0.50") to allow for levelling.
3. Allow a minimum clearance of 1100mm (42") on the front and 920mm (36") on the top, left right and rear of the package for proper air circulation and serviceability.
4. Approximate package weight: 455kg (1000lbs).
5. External piping shall not exert any unresolved moments or forces on the unit. Use pipe size as large or larger at discharge connection.
6. There should be no plastic or pvc piping attached to this unit or used for any lines downstream.
7. Do not pipe into a common header with a reciprocating compressor, unless the reciprocating compressor utilizes a discharge pulsation damper.
8. Sizing of electrical components not supplied by **Ingersoll Rand** is the responsibility of the customer and should be done in accordance with the information on the compressor data plate and national and local electrical codes.

NOTE

All dimensions are in millimetres (inches) unless otherwise stated.

Ensure that the correct fork lift truck slots or marked lifting points are used whenever the machine is lifted or transported.

UNPACKING

The compressor will normally be delivered with a polythene cover. If a knife has to be used to remove this cover ensure that the exterior paintwork of the compressor is not damaged.

Ensure that all transport and packing materials are discarded in a manner prescribed by local codes.

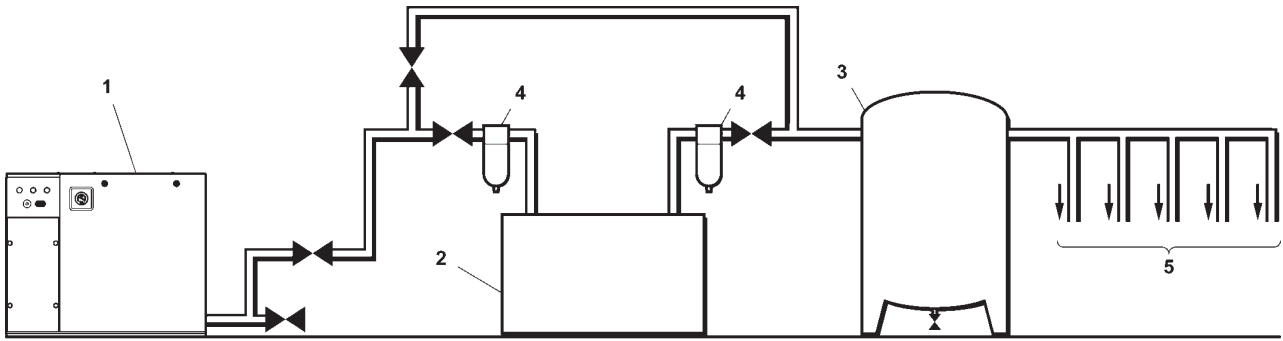

T5973
Revision 00
06/04

KEY
1. Compressor
2. Air Receiver
3. Air Dryer
4. Compressed air filters
5. System demand points

NOTE

Items [2] to [5] are optional or may be existing items of plant. Refer to your Ingersoll Rand distributor / representative for specific recommendations.

CAUTION

The use of plastic bowls on line filters and other plastic air line components can be hazardous. Their safety can be affected by either synthetic coolants or the additives used in mineral oils. Ingersoll Rand recommends that only filters with metal bowls should be used on any pressurised system.

CAUTION

The standard compressor unit is not suitable for operation in temperatures liable to cause freezing as Condensate water is liable to be produced in the after cooler and receiver where fitted.

Refer to your Ingersoll Rand distributor for further information.

LOCATION IN THE PLANT

The compressor can be installed on any level floor capable of supporting it. A dry, well ventilated area where the atmosphere is clean is recommended. A minimum of 1m (3ft) should be left all around machine for adequate service access and ventilation.

Adequate clearance needs to be allowed around and above the machine to permit safe access for specified maintenance tasks.

Ensure that the machine is positioned securely and on a stable foundation. Any risk of movement should be removed by suitable means, especially to avoid strain on any rigid discharge piping.

CAUTION

Screw type compressors [1] should not be installed in air systems with reciprocating compressors without means of isolation such as a common receiver tank. It is recommended that both types of compressor be piped to a common receiver using individual air lines.

DISCHARGE PIPING

Discharge piping should be at least as large as the discharge connection of the compressor. All piping and fittings should be suitably rated for the discharge pressure.

It is essential when installing a new compressor [1], to review the total air system. This is to ensure a safe and effective total system. One item which should be considered is liquid carryover. Installation of air dryers [3] is always good practice since properly selected and installed they can reduce any liquid carryover to zero.

It is good practice to locate an isolation valve close to the compressor and to install line filters [4].

It is a requirement for air dryers covered under AirCare that correctly sized **Ingersoll Rand** pre and afterfilters are installed.

60Hz	UP6 5			UP6 7			UP6 10			UP6 15c		
COMPRESSOR	125	150	210	125	150	210	125	150	210	125	150	210
Operating pressure PSIG (bar)	125 (8.6)	150 (10.3)	--	125 (8.6)	150 (10.3)	210 (14.5)	125 (8.6)	150 (10.3)	210 (14.5)	125 (8.6)	150 (10.3)	210 (14.5)
Factory set reload pressure PSIG (bar)	110 (7.58)	130 (8.96)	--	110 (7.58)	130 (8.96)	180 (12.41)	110 (7.58)	130 (8.96)	180 (12.41)	110 (7.58)	130 (8.96)	180 (12.41)
Flow rate CFM (m ³ /MIN)	18.5 (0.52)	16.0 (0.45)	--	28.0 (0.79)	25.0 (0.71)	17.5 (0.50)	38.0 (1.08)	34 (0.96)	24.0 (0.68)	55.0 (1.55)	50.0 (1.42)	38.0 (1.08)

Airend discharge temperature trip point.	228°F (109°C)											
Ambient operating temperature (min.) →(max.)	36°F (+2°C) → 105°F (+40°C)											

MOTOR										
Motor enclosure	ODP	TEFC	ODP	TEFC	ODP	TEFC	ODP	TEFC	ODP	TEFC
Nominal power	5HP		7.5HP		10HP		15HP			
Speed	3500 RPM									
Insulation class	F									

GENERAL DATA										
Residual coolant content	3ppm (3 mg/m ³)									
Separator vessel capacity	0.8 gallons (3 Litres)									
Coolant capacity	1.2 gallons (4.5 Litres)									
Sound pressure level to CAGI-PNEUROP	65 dB(A)		65 dB(A)		68 dB(A)		69 dB(A)			
Weight-base mount unit	295kg (650lb)									
Weight-80 gallon Receiver mounted	420kg (925lb)									
Weight-120 gallon Receiver mounted	436kg (960lb)									

CAUTION

230/460 Dual voltage machines are fitted with a decal to advise the correct voltage as connected from the factory. There is a decal fitted to the starter door describing the procedure to change the connections for the alternative voltage.

Rewiring should only be effected by a competent Electrician.

50Hz	UP5 4			UP5 5			UP5 7			UP5 11c		
COMPRESSOR	8	10	14.5	8	10	14.5	8	10	14.5	8	10	14.5
Operating pressure PSIG (bar)	115 (8)	145 (10)	210 (14.5)	115 (8)	145 (10)	210 (14.5)	115 (8)	145 (10)	210 (14.5)	115 (8)	145 (10)	210 (14.5)
Factory set reload pressure PSIG (bar)	100 (7.58)	125 (8.96)	--	100 (7.93)	125 (9.66)	180 (13.10)	100 (7.93)	125 (9.66)	180 (13.10)	100 (7.93)	125 (9.66)	180 (13.1)
Flow rate CFM (m ³ /MIN)	19.5 (0.55)	16.0 (0.45)	--	29.0 (0.82)	26.0 (0.74)	18.0 (0.51)	38.0 (1.08)	34 (0.96)	24.0 (0.68)	56.5 (1.60)	50.0 (1.92)	38.0 (8.6)

Airend discharge temperature trip point.	228°F (109°C)
Ambient operating temperature (min.) →(max.)	36°F (+2°C) → 105°F (+40°C)

MOTOR				
Motor enclosure	TEFC			
Nominal power	4KW	5.5KW	7.5KW	11KW
Speed	2900 RPM			
Insulation class	F			

GENERAL DATA				
Residual coolant content	3ppm (3 mg/m3)			
Separator vessel capacity	0.8 gallons (3 Litres)			
Coolant capacity	1.2 gallons (4.5 Litres)			
Sound pressure level to CAGI-PNEUROP	65 dB(A)	65 dB(A)	68 dB(A)	69 dB(A)
Weight-base mount unit	295kg (650lb)			
Weight-272 Litres-Receiver mounted	420kg (925lb)			
Weight-500 Litres Receiver mounted	454kg (1000lb)			

DRYER ENGINEERING DATA	60Hz	50Hz
Electrical supply	115V - 1ph - 60Hz	230V - 1ph - 50Hz
L.R.A. current (Amps)	30.0	12.6
F.L.A. current (Amps)	5.0	2.7
Total installed power (kW)	0.46	0.47
Electrical protection class (std)	NEMA 1 (IP 20)	
Factory refrigerant charge (lb/g)	0.78 lb 354 g	
Refrigeration type	134 A	

CAUTION
 230/460 Dual voltage machines are fitted with a decal to advise the correct voltage as connected from the factory. There is a decal fitted to the starter door describing the procedure to change the connections for the alternative voltage. Rewiring should only be effected by a competent Electrician.

ELECTRICAL DATA-UP6 5

Standard voltage	230V/1PH	200V	230V/3PH	460V	575V
Full load current (maximum)	23.5A	15.5A	13.5A	6.8A	5.4A
Starting current DOL (Star Delta)	-	-	-	-	-
Starting time DOL (Star Delta)	3-5 Sec (7-10 Sec)				
Starts per hour (maximum)	6				
Control voltage	120VAC				
Recommended fuse rating See note 1	40A	25A	20A	10A	8A
Recommended wire size AWG See note 2	8	10	12	14	14

ELECTRICAL DATA-UP6 7.5					
Standard voltage	230V/1PH	200V	230V/3PH	460V	575V
Full load current (maximum)	34.1A	22.7A	19.7A	9.9A	7.9A
Starting current DOL (Star Delta)	-	-	-	-	-
Starting time DOL (Star Delta)	3-5 Sec (7-10 Sec)				
Starts per hour (maximum)	6				
Control voltage	120VAC				
Recommended fuse rating See note 1	50A	35A	35A	15A	12A
Recommended wire size AWG See note 2	6	8	10	14	14

ELECTRICAL DATA-UP6 10					
Standard voltage	230V/1PH	200V	230V/3PH	460V	575V
Full load current (maximum)	-	29.8A	26.0A	13.0A	10.3A
Starting current DOL (Star Delta)	-	-	-	-	-
Starting time DOL (Star Delta)	3-5 Sec (7-10 Sec)				
Starts per hour (maximum)	6				
Control voltage	120VAC				
Recommended fuse rating See note 1	-	50A	45A	20A	15A
Recommended wire size AWG See note 2	-	8	8	12	14

ELECTRICAL DATA-UP6 15c					
Standard voltage	230V/1PH	200V	230V/3PH	460V	575V
Full load current (maximum)	-	43.2A	37.6A	18.8A	15.1A
Starting current DOL (Star Delta)	-	-	-	-	-
Starting time DOL (Star Delta)	3-5 Sec (7-10 Sec)				
Starts per hour (maximum)	6				
Control voltage	120VAC				
Recommended fuse rating See note 1	-	75A	65A	30A	25A
Recommended wire size AWG See note 2	-	4	6	10	10

1. If a circuit breaker is selected it should only be a magnetic trip type, set above the anticipated starting current of the machine, but below the maximum prospective fault current for the circuit. The circuit breaker or fuseable disconnect must be capable of breaking the prospective fault current at its terminals.

2. PVC/PVC Type Calculated using the following conditions:

- i) PVC insulated cable, armoured, copper conductors.
- ii) Cable clipped to a wall, in free air.
- iii) Ambient temperature of 40°C (104°F) and relative humidity of 40%.
- iv) 20m (65ft) cable run.
- v) Volt drop limited to -10% during starting, -4% during normal running.
- vi) Protected by the circuit breaker listed above.

ELECTRICAL DATA-UP5 4		
Standard voltage	380V	400V
Full load current (maximum)	8.9A	8.5A
Starting current DOL (Star Delta)	66	63
Starting time DOL (Star Delta)	3-5 Sec (7-10 Sec)	
Starts per hour (maximum)	6	
Control voltage	120VAC	
Recommended fuse rating See note 1	16A	16A
Recommended wire size See note 2	4 mm ² Cu	4 mm ² Cu

ELECTRICAL DATA-UP5 5.5		
Standard voltage	380V	400V
Full load current (maximum)	11.8A	11.2A
Starting current DOL (Star Delta)	100	95
Starting time DOL (Star Delta)	3-5 Sec (7-10 Sec)	
Starts per hour (maximum)	6	
Control voltage	120VAC	
Recommended fuse rating See note 1	16A	16A
Recommended wire size See note 2	4 mm ² Cu	4 mm ² Cu

ELECTRICAL DATA-UP5 7.5		
Standard voltage	380V	400V
Full load current (maximum)	16.9A	15.6A
Starting current DOL (Star Delta)	121 (94)	114 (52)
Starting time DOL (Star Delta)	3-5 Sec (7-10 Sec)	
Starts per hour (maximum)	6	
Control voltage	120VAC	
Recommended fuse rating See note 1	20A	20A
Recommended wire size See note 2	4 mm ² Cu	4 mm ² Cu

ELECTRICAL DATA-UP5 11c		
Standard voltage	380V	400V
Full load current (maximum)	23.0A	21.9A
Starting current DOL (Star Delta)	(79)	(75)
Starting time DOL (Star Delta)	3-5 Sec (7-10 Sec)	
Starts per hour (maximum)	6	
Control voltage	120VAC	
Recommended fuse rating See note 1	32A	32A
Recommended wire size See note 2	6 mm ² Cu	6 mm ² Cu

1. If a circuit breaker is selected it should only be a magnetic trip type, set above the anticipated starting current of the machine, but below the maximum prospective fault current for the circuit. The circuit breaker or fuseable disconnect must be capable of breaking the prospective fault current at its terminals.

2. PVC/PVC Type Calculated using the following conditions:

- i) PVC insulated cable, armoured, copper conductors.

- ii) Cable clipped to a wall, in free air.
- iii) Ambient temperature of 40°C (104°F) and relative humidity of 40%.
- iv) 20m (65ft) cable run.
- v) Volt drop limited to -10% during starting, -4% during normal running.
- vi) Protected by the circuit breaker listed above.

If there are any deviations from the above, or special regulations apply, the installation must be planned by a competent, qualified engineer.

NOTE

All data applies to standard product only.

ELECTRICAL DATA

An independent electrical isolator or disconnect should be installed adjacent to the compressor.

Feeder cables/wires should be sized by the customer/ electrical contractor to ensure that the circuit is balanced and not overloaded by other electrical equipment. The length of wiring from a suitable electrical feed point is critical as voltage drops may impair the performance of the compressor.

Feeder cables / wires connections to isolator or disconnect should be tight and clean.

The applied voltage must be compatible with the motor and compressor data plate ratings.

The control circuit transformer has different voltage tapings. Ensure that these are set for the specific applied voltage prior to starting.

CAUTION

Never test the insulation resistance of any part of the machines electrical circuits, including the motor without completely disconnecting the electronic controller (where fitted).

CAUTION

Ensure that the motor rotates in the correct direction as indicated by direction arrows.

OPERATING INSTRUCTIONS

GENERAL OPERATION

The compressor is an electric motor driven, single stage screw compressor, complete with accessories piped, wired and base plate mounted. It is a totally self contained air compressor package.

The standard compressor is designed to operate in an ambient range of 35.6°F - 104°F (2°C to 40°C). The maximum temperature is applicable up to a maximum elevation of 3280ft (1000m) above sea level. Above this altitude significant reduction in maximum allowable ambient temperature is required.

Compression in the screw type air compressor is created by the meshing of two (male & female) helical rotors.

The air/coolant mixture discharges from the compressor into the separation system. This system removes all but a few PPM of the coolant from the discharge air. The coolant is returned to the cooling system and the air passes through the aftercooler and out of the compressor.

Cooling air is moved through the coolers by the cooling fan and discharged from the machine.

CAUTION

Cooling air is drawn in at the rear of the machine package passing through the filter and cooler before being discharged from the top of the machine. Care should be taken to avoid blocking the airflow, or causing any restriction in excess of the maximum backpressure allowed for ducting.

Do not direct the airflow at face or eyes.

By cooling the discharge air, much of the water vapour naturally contained in the air is condensed and may be drained from the downstream piping and equipment.

The coolant system consists of a sump, cooler, thermostatic valve and a filter. When the unit is operating, the coolant is pressurized and forced to the compressor bearings.

The compressor load control system is automatic **on-off line**. This allows the compressor to maintain a set discharge line pressure by varying output capacity to match the system demand. The unit is provided with an automatic stop and restart system for use in plants where the air demand varies sufficiently to allow a compressor to shut down and save power. Significant system volume will assist this and is recommended.

When the compressor is equipped with the optional dryer, the dryer will cycle on and off with the compressor.

WARNING

When the unit stops running as the result of low air demand, it may restart and return to load at any time.

Safety of operation is provided as the compressor will shut down if excessive temperatures or electrical overload conditions should occur.

CAUTION

This unit is not designed or intended to operate when contaminated with silicone. Lubricants, greases or other items containing silicone should not be used on this unit.

CAUTION

LOW DEMAND APPLICATIONS
During periods of low demand, the compressor may not reach its normal operating temperature. Sustained operation at low demand can result in the build up of condensate in the coolant. If this situation occurs, the lubricating characteristics of the coolant can be impaired which may lead to damage of the compressor.

THE COMPRESSOR SHOULD BE ALLOWED AMPLE LOADED RUNNING TIME OF AT LEAST 10 MINUTES PER HOUR DURING NORMAL DAILY USE.

COMPRESSOR CONTROLS

Direct online starting:

The compressor is equipped for Automatic Start & Stop Control. When the receiver tank pressure reaches the factory pre-set maximum pressure, the pressure switch stops the unit. When the receiver tank pressure drops below the factory pre-set minimum. The pressure switch resets and restarts the unit.

The pressure switch cover can be removed by unscrewing the two screws holding the cover.

Pressure switch adjustment:

The compressor package will cut-in and cut-out at factory preset pressure settings. Adjust the pressure switch only if absolutely necessary.

Adjustments are to be carried out only when the switch is mounted, under pressure and voltage-free.

WARNING

High voltage is present at the pressure switch contacts when the power supply is connected. Disconnect, lock and tag main power supply before making adjustments.

WARNING

Do not adjust the pressure switch to exceed the maximum discharge pressure of the unit.

NOTE

When replacing the pressure switch cover, ensure the selector knob on the cover and the lever on the switch are both in the "OFF" position.

NOTE

When the compressor is equipped with the optional dryer and filters, the pressure switch differential should be increased 10psi to account for the added pressure drop of the filters and dryer.

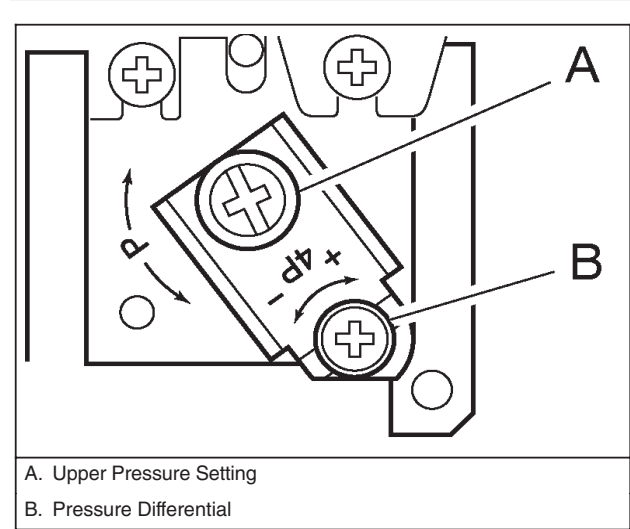

AUTOMATIC START & STOP CONTROL

NOTE

Automatic Start & Stop Control is intended for use when the motor will start no more than 6 times per hour.

When the receiver tank pressure reaches the factory pre-set maximum pressure, the pressure switch stops the unit. When the receiver tank pressure drops below the factory pre-set minimum, the pressure switch resets and restarts the unit.

DUAL CONTROL

Select either automatic start and stop control or constant speed control by adjusting the knob on the auxiliary valve. For automatic start and stop control, turn the knob on the auxiliary valve fully clockwise to disable the auxiliary valve. The pressure switch will then start and stop the unit.

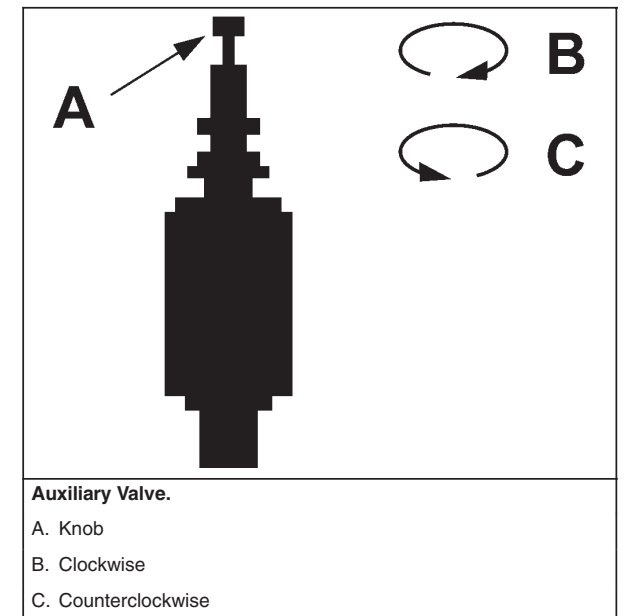

Select constant speed control if the unit restarts in less than 10 minute intervals or runs more than 40 minutes per hour. Turn the knob fully counterclockwise to run the unit continually.

NOTE

The auxillary valve is factory pre-set at 5 psig (0,3 bar) lower than the factory pressure switch setting.

CAUTION

Running unloaded with no air demand, will cause the unit to be shutoff by the pressure switch.

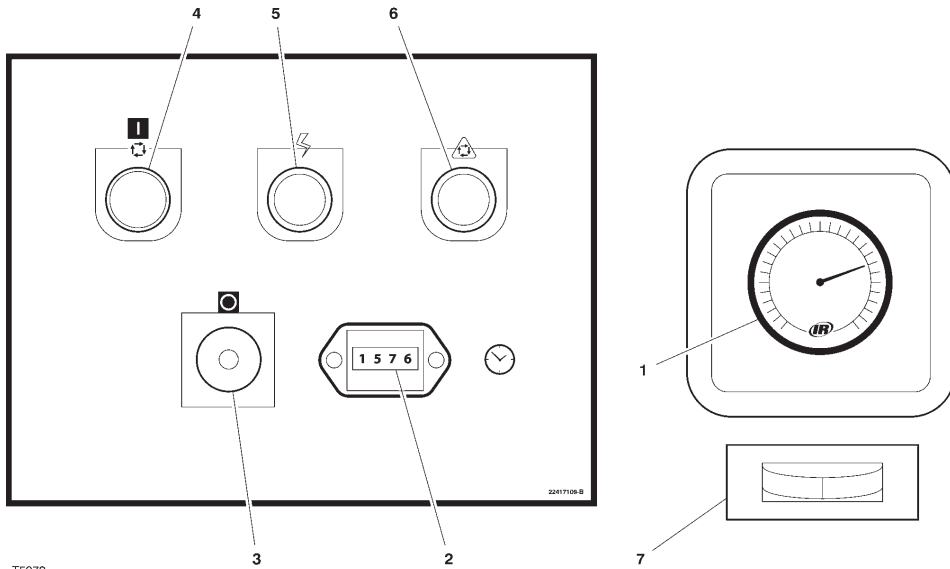

1. PRESSURE GAUGE

Indicates the system pressure.

WARNING

DO NOT operate the compressor at discharge pressures exceeding the maximum operating pressure.

2. HOURMETER

Records the total running time of the compressor.

3. STOP BUTTON / EMERGENCY STOP

When depressed will stop the compressor immediately. The 'Power on' indicator will remain illuminated. The STOP button must be released before the compressor can be restarted.

4. ON PUSH BUTTON SWITCH

When depressed will cause the unit to start and run in a loaded condition if there is a demand for air. If there is no demand, the machine will stop automatically.

5. POWER ON INDICATOR LIGHT (Green)

Indicates the presence of control voltage.

6. STOPPED/AUTO RESTART INDICATOR LIGHT (Amber)

Will illuminate when the machine has shut-down due to low air demand. The machine will restart and load automatically as soon as the demand for air returns.

7. DEW POINT INDICATOR (Dryer Option)

Green indicates good dew point. Red indicates dew point above 50°F (10°C) Blue indicates freezing.

PRIOR TO STARTING

1. Make visual check of the machine, ensure that all guards secure and that nothing is obstructing the proper ventilation of, or free access to the machine.
2. Check coolant level. Add if necessary.
3. Make sure air discharge valve is open.
4. Turn on electrical isolator or disconnect. The **Power on** (5) indicator will light, indicating that line and control voltages are available.
5. Check direction of rotation at initial start or following interruption in power supply.

WARNING

Make sure that all protective covers are in place.

Cooling air flow exhaust may contain flying debris. Safety protection should be worn at all times to avoid injury.

STARTING

1. Press the START button. The compressor will start and then load automatically.

NORMAL/EMERGENCY STOPPING

1. Press STOP button (3) and the compressor will stop immediately.
2. Turn off electrical isolator or disconnect.

CAUTION

After shutdown never allow unit to stand idle with pressure in receiver/separator system.

MAINTENANCE

MAINTENANCE SCHEDULE

UP Series Maintenance Schedule	
PERIOD	MAINTENANCE
Each 24 hours operation	Check the coolant level and replenish if necessary.
Visual check of machine for any leaks, dust build up or unusual noise or vibration	Report immediately, contact Ingersoll Rand authorized distributor for assistance if in doubt.
When compressor is receiver mounted	Drain air receiver of condensate, or check that automatic drain is operating.
Visual check condition of package pre-filter	Blow clean if needed.
First 150 hours	Change the coolant filter.
Each month or 100 hours	Remove and clean package pre-filter, replace if needed Check the cooler(s) for build up of foreign matter. Clean if necessary by blowing out with air or by pressure washing.
Each year or 2000 hours	Check the operation of the high temperature protection switch (109°C).
	Replace elements in IRGP and IRHE filters.
	Change the coolant filter.
	Check scavenge screen for blockage, clean if required.
	Change the separator element.
	Change the Air Filter element.
	Take coolant sample for fluid analysis.
	Change the package pre-filter.
	Check Drive Belts.
1 year external and 6 years internal pressure vessel inspection. Frequency may be otherwise defined by local or national legislation.	<i>Separator vessel and air receiver when fitted.</i> Fully inspect all external surfaces, and fittings. Report any excessive corrosion, mechanical or impact damage, leakage or other deterioration.
Every two years or 8000 hours	Change drive belts.
	Replace the <i>Ultra</i> at whichever interval occurs first.
	Check and replace all items included within 2000 hour service.
	Fit the following reconditioning parts as appropriate: Solenoid valves Inlet valve kit Minimum Pressure valve kit Thermostatic Valve Kit
Every 4 years or 16000 hours	Replace all hoses.
	Check motors with grease fittings and grease per motor data tag
	Fit replacement electrical contactor tips.
	Motors without grease fittings - Replace sealed bearings

ROUTINE MAINTENANCE

This section refers to the various components which require periodic maintenance and replacement.

It should be noted that the intervals between service requirement may be significantly reduced as a consequence of poor operating environment. This would include effects of atmospheric contamination and extremes of temperature.

The *SERVICE/MAINTENANCE CHART* indicates the various components' descriptions and the intervals when maintenance has to take place. Oil capacities, etc., can be found in the *GENERAL INFORMATION* section of this manual.

Compressed air can be dangerous if incorrectly handled. Before doing any work on the unit, ensure that all pressure is vented from the system and that the machine cannot be started accidentally.

CAUTION

Before beginning any work on the compressor, open, lock and tag the main electrical disconnect and close the isolation valve on the compressor discharge. Vent pressure from the unit by slowly unscrewing the coolant fill cap one turn. Unscrewing the fill cap opens a vent hole, drilled in the cap, allowing pressure to release to atmosphere. Do not remove the fill cap until all pressure has vented from the unit. Also vent piping by slightly opening the drain valve. When opening the drain valve or the coolant fill cap, stand clear of the valve discharge and wear appropriate eye protection.

Ensure that maintenance personnel are properly trained, competent and have read the Maintenance Manuals.

Prior to attempting any maintenance work, ensure that:-

- all air pressure is fully discharged and isolated from the system. If the automatic blowdown valve is used for this purpose, then allow enough time for it to complete the operation.
- the machine cannot be started accidentally or otherwise.
- all residual electrical power sources (mains and battery) are isolated.

Prior to opening or removing panels or covers to work inside a machine, ensure that:-

- anyone entering the machine is aware of the reduced level of protection and the additional hazards, including hot surfaces and intermittently moving parts.
- the machine cannot be started accidentally or otherwise.

Prior to attempting any maintenance work on a running machine, ensure that:-

DANGER

Only properly trained and competent persons should undertake any maintenance tasks with the compressor running or with electrical power connected.

- the work carried out is limited to only those tasks which require the machine to run.
- the work carried out with safety protection devices disabled or removed is limited to only those tasks which require the machine to be running with safety protection devices disabled or removed.
- all hazards present are known (e.g. pressurised components, electrically live components, removed panels, covers and guards, extreme temperatures, inflow and outflow of air, intermittently moving parts, safety valve discharge etc.).
- appropriate personal protective equipment is worn.
- loose clothing, jewellery, long hair etc. is made safe.
- warning signs indicating that *Maintenance Work is in Progress* are posted in a position that can be clearly seen.

Upon completion of maintenance tasks and prior to returning the machine into service, ensure that:-

- the machine is suitably tested.
- all guards and safety protection devices are refitted and correctly working.
- all panels are replaced, canopy and doors closed.
- hazardous materials are effectively contained and disposed of in a manner compliant with local or National environmental protection codes.

WARNING

Do not under any circumstances open any drain valve or remove components from the compressor without first ensuring that the compressor is FULLY SHUT- DOWN, power isolated and all air pressure relieved from the system.

TOP UP COOLANT PROCEDURE

1. Slowly remove fill cap.
2. Pour coolant into spout until spout almost overflows.
3. Replace and tighten oil fill cap.
4. Start unit for about 10 seconds (until coolant drains out the bottom of the sight glass).
5. Slowly remove fill cap.
6. Re-fill into spout until spout almost overflows.
7. Replace and tighten oil fill cap.
8. Run unit.

NOTE

Coolant level is correct when a unit is showing coolant in bottom half of sight glass when up to operating temperature (ten minutes running loaded).

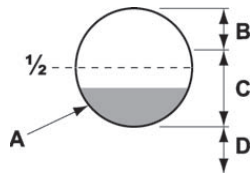

- A. Correct at operating temperature
- B. Too much
- C. OK
- D. Too little

Repeat this procedure to get coolant to proper level when up to operating temperature. When the unit is shut down, coolant will usually fill up sight glass. Do not adjust level based on level at shutdown. Proper level is always set for a running unit at operating temperature.

CAUTION

Ensure that SSR ULTRA is used. Failure to do so will void manufacturers warranty.

COOLANT CHANGE PROCEDURE

It is better to drain the coolant immediately after the compressor has been operating as the liquid will drain more easily and any contaminant will still be in suspension.

1. Stop the machine, electrically isolate and vent all trapped pressure.
2. Place a suitable container close to the drain valve.
3. Slowly remove fill cap.
4. Remove plug from drain valve.
5. Open the drain valve and drain coolant into container.
6. Close the drain valve.
7. Replace plug in drain valve.
8. Refill the machine following the "top up coolant" procedure above. After initial fill, to purge any airlocks, the machine should be run for a few minutes cycling between load and no load, before checking that the level is correct.
9. Replace and tighten oil fill cap.

COOLANT FILTER CHANGE PROCEDURE

1. Stop the machine, electrically isolate and vent all trapped pressure.
2. Loosen filter with the correct tool.
3. Remove the filter from the housing.
4. Place the old filter in a sealed bag and dispose of in a safe way.
5. Clean the mating face of the housing taking care to avoid any particles entering the machine.
6. Remove the new **Ingersoll Rand** replacement filter from its protective package.
7. Apply a small amount of lubricant to the filter seal.
8. Screw the new filter down until the seal makes contact with the housing, then hand tighten a further half turn.
9. Start the compressor and check for leaks.

AIR FILTER ELEMENT CHANGE PROCEDURE

1. Stop the machine, electrically isolate and vent all trapped pressure.
2. Unscrew the retaining cap and withdraw the old element.
3. Fit the new element.
4. Replace the retaining cap.

SEPARATOR ELEMENT CHANGE PROCEDURE

1. Stop the machine, electrically isolate and vent all trapped pressure.
2. Loosen separator element with the correct tool.
3. Remove the element from the housing; place it in a sealed bag and dispose of it safely.
4. Clean the mating face of the housing.
5. Remove the new **Ingersoll Rand** replacement element from its protective package.
6. Apply a small amount of lubricant to the element seal.
7. Screw the new element down until the seal makes contact with the housing, then hand tighten a further half turn.
8. Start the compressor and check for leaks.

CAUTION

This unit is not designed or intended to operate when contaminated with silicone. Lubricants, greases or other items containing silicone should not be used on this unit.

COOLER CLEANING PROCEDURE

1. Stop the machine, electrically isolate and vent all trapped pressure.
2. Remove the top cover to obtain access to the cooler.

3. Clean the cooler.
4. Rebuild in reverse order.

BELT CHECKING AND ADJUSTMENT PROCEDURE

Check belt tension occasionally, especially if looseness is suspected. A quick check to determine if adjustment is proper may be made by observing the slack side of the belt for a slight bow when the unit is in operation. If a slight bow is evident, the belt is usually adjusted satisfactorily.

A belt tension measurement device can be used to determine the tension of the belt.

Belt tensioning can be achieved by loosening the airend anchor screws, a belt tensioning bolt is provided to aid in moving the airend.

Follow the procedures outlined below to correctly set and measure belt tension.

1. Lay a straight edge across the top outer surface of the belt drive from pulley to sheave.
2. At the center of the span, perpendicular to the belt, apply pressure to the outer surface of the belt with a tension gauge. Force the belt to the deflection indicated in the table below, and compare the reading on the tension gauge to the figures shown.

BELT TENSION

	5hp/4kw *		7.5hp/5.5kw *		10hp/7.5kw *		15hp/11kw **	
	New	Used	New	Used	New	Used	New	Used
60hz								
125 psig	75 Lb (34 Kg)	62 Lb (28 Kg)	110 Lb (50 Kg)	90 Lb (41 Kg)	110 Lb (50 Kg)	90 Lb (41 Kg)	140 Lb (64 Kg)	120 Lb (54 Kg)
150 psig	75 Lb (34 Kg)	62 Lb (28 Kg)	90 Lb (41 Kg)	75 Lb (34 Kg)	110 Lb (50 Kg)	90 Lb (41 Kg)	140 Lb (64 Kg)	120 Lb (54 Kg)
210 psig	75 Lb (34 Kg)	62 Lb (28 Kg)	90 Lb (41 Kg)	75 Lb (34 Kg)	110 Lb (50 Kg)	90 Lb (41 Kg)	150 Lb (68 Kg)	125 Lb (57 Kg)
50hz								
8 bar	85 Lb (39 Kg)	70 Lb (32 Kg)	85 Lb (39 Kg)	70 Lb (32 Kg)	110 Lb (50 Kg)	90 Lb (41 Kg)	140 Lb (64 Kg)	120 Lb (54 Kg)
10 bar	90 Lb (41 Kg)	75 Lb (34 Kg)	85 Lb (39 Kg)	70 Lb (32 Kg)	120 Lb (54 Kg)	100 Lb (45 Kg)	140 Lb (64 Kg)	120 Lb (54 Kg)
14.5 bar	90 Lb (41 Kg)	75 Lb (34 Kg)	100 Lb (45 Kg)	80 Lb (36 Kg)	120 Lb (54 Kg)	100 Lb (45 Kg)	150 Lb (68 Kg)	125 Lb (57 Kg)

* "Kriket I" gauge or equal

** "Kriket II" gauge or equal

Ensure the pulley and sheave are properly aligned and the motor anchor screws are adequately retightened prior to restarting the compressor.

CAUTION

Improper pulley/sheave alignment and belt tension can result in motor overload, excessive vibration, and premature belt and/or bearing failure.
To prevent these problems from occurring, ensure the pulley and sheave are aligned and belt tension is satisfactory after installing new belts or tensioning existing belts.

ELECTRIC DRAIN VALVE (OPTIONAL)

PRODUCT DESCRIPTION

The Electric Drain Valve removes condensed water and oil from the air receiver tank. Additional drains may be installed throughout your compressed air system, including aftercoolers, filters, drip legs and dryers.

The Electric Drain Valve operates on a timer which can be set to automatically drain the air receiver tank at operator-determined intervals.

Key features include:

- 100% continuous duty
- NEMA 4 enclosure
- Adjustable time on (0.5 - 10 seconds)
- Adjustable time off (0.5 - 45 minutes)
- Stainless steel operator
- LED to indicate electrical power is on
- LED to indicate valve is open
- Manual override

OPERATION

1. Open the strainer ball valve.

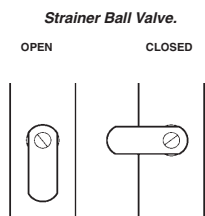

2. Set the "time off" and "time on" knobs. See **TIMER SETTINGS** (below) for an explanation of the settings.
3. During compressor operation, check for air leaks.

TIMER SETTINGS

The "time off" setting determines the interval between

cycles from 30 seconds to 45 minutes. The "time on" setting determines the actual time the compressor drains condensate.

The timer's cycle rate and drain opening time should be adjusted to open just long enough to discharge the condensate. The timer is properly set when it opens and discharges condensate and then vents air for approximately one second before closing. Adjustments may be made depending on many factors, including humidity and duty cycle.

TROUBLESHOOTING

TROUBLE	CAUSE	ACTION
Valve will not close.	Debris in solenoid valve prevents diaphragm from seating.	Remove solenoid valve, disassemble, clean and reassemble.
	Short in electrical component.	Check and replace power cord or timer as needed.
Timer will not activate	No electrical supply.	Apply power.
	Timer malfunction	Replace timer.
	Clogged port.	Clean valve.
	Solenoid valve malfunction.	Replace solenoid valve.
	Clogged strainer.	Clean strainer.

MAINTENANCE

Periodically clean the screen inside the valve to keep the drain functioning at maximum capacity. To do this, perform the following steps:

1. Close the strainer ball valve completely to isolate it from the air receiver tank.
2. Press the TEST button on the timer to vent the pressure remaining in the valve. Repeat until all pressure is removed.

CAUTION

High pressure air can cause injury from flying debris. Ensure the strainer ball valve is completely closed and pressure is released from the valve prior to cleaning.

3. Remove the plug from the strainer with a suitable wrench. If you hear air escaping from the cleaning port, STOP IMMEDIATELY and repeat steps 1 and 2.
4. Remove the stainless steel filter screen and clean it. Remove any debris that may be in the strainer body before replacing the filter screen.
5. Replace plug and tighten with wrench.
6. When putting the Electric Drain Valve back into service, press the TEST button to confirm proper function.

Before accessing live electrical parts, disconnect the power supply to the dryer using disconnect switch or disconnect the cable connections.

Preventive maintenance

For optimum performance from your dryer, follow the periodic maintenance schedule described below.

WEEKLY	CONDENSATE DRAINS Verify that the condensate drains are operating correctly.
EVERY 4 MONTHS	CONDENSER Remove any dust from the condenser fins. COMPRESSOR Make sure compressor power consumption complies with data plate specifications.
YEARLY	CONDENSATE DRAINS Completely disassemble the drains and clean all their components. AIR FILTER Replace air filter element.

MOISTURE SEPARATOR MAINTENANCE

The moisture separator will operate indefinitely under normal working conditions, however at some time it may be necessary to replace the seals should the housing leak.

1. Isolate the housing from the air supply.
2. Fully depressurize in drain bowl as appropriate.
3. Unscrew bowl and remove. If pressure has not been completely released from the housing, air will escape from the warning hole giving an audible alarm. Screw back bowl and repeat instruction 2 before attempting again. Should resistance to unscrewing be experienced, provision is made for a 'C' spanner to fit onto the ribs of the bowl.
4. Check condition of bowl seal and replace if necessary. Clean screw threads.
5. Refit bowl with 'O' ring seal.
6. Repressurize and check for leaks. If leaks occur they will most probably be from the bowl 'O' ring. Depressurize housing and remove 'O' ring as stated above and inspect and clean. Ensure that mating surfaces are clean and then refit 'O' ring and repressurize.

AIR FILTER MAINTENANCE

In order to ensure optimum compressed air quality the filter element should be replaced as follows. (Used filter elements must be disposed of in accordance with local regulations.)

Use only genuine **Ingersoll Rand** replacement elements.

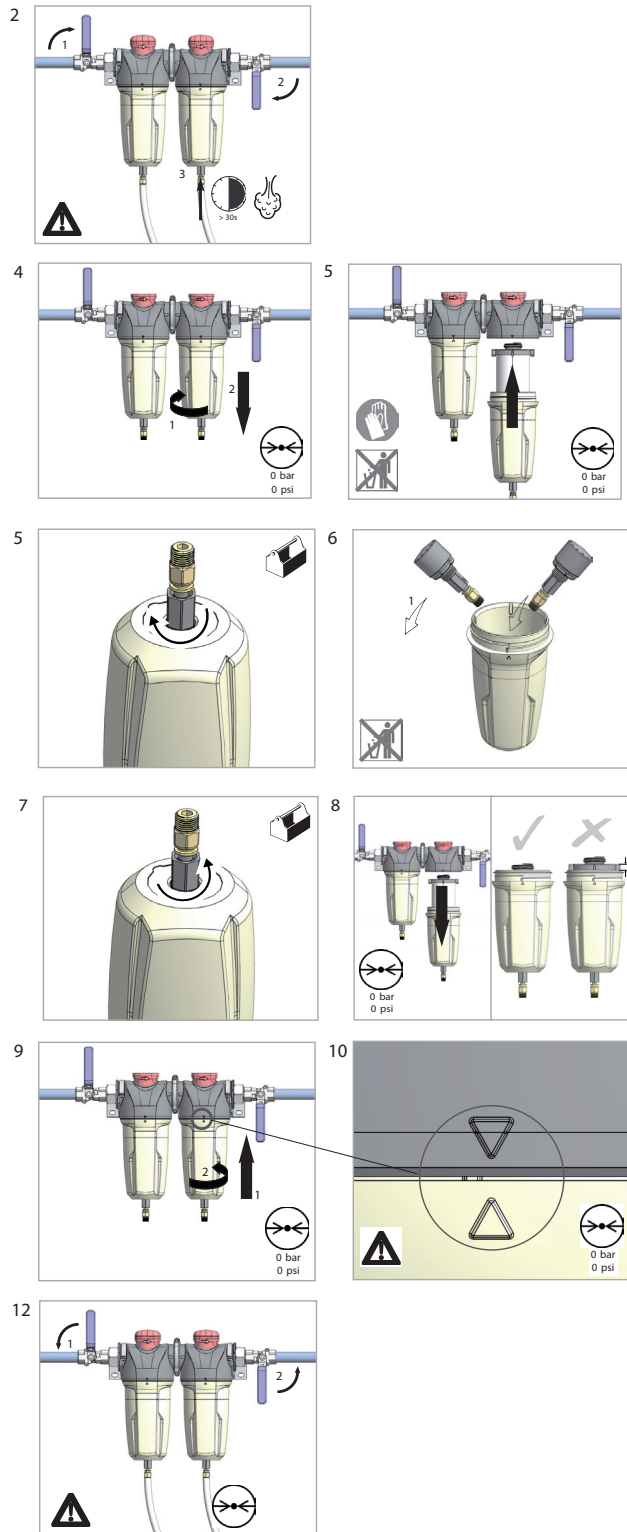

DISASSEMBLING THE UNIT

The unit has been designed and constructed to guarantee continuous operation.

The long service life of some components such as the fan and compressor depends on good maintenance.

The unit must only be disassembled by a refrigerant specialist.

Refrigerant liquid and lubricating oil inside the refrigeration circuit must be recovered in compliance with current norms in the country where the machine is installed.

RECYCLING DISASSEMBLY	
Frame and panels	Steel / epoxy resin polyester
Heat exchanger (cooler)	Stainless steel
Pipes	Copper
Insulation	Gum synthetic
Compressor	Steel / copper / aluminium / oil
Condenser	Aluminium
Refrigerant	R134a
Valve	Steel

REFRIGERANT LEAKS IN THE REFRIGERATION CIRCUIT

The unit is despatched in perfect working order, already charged.

Refrigerant leaks may be identified by tripping of the refrigeration overload protector.

IF A LEAK IS DETECTED IN THE REFRIGERANT CIRCUIT, SEEK TECHNICAL ASSISTANCE.

REFRIGERANT CHARGING

THIS OPERATION MUST ONLY BE PERFORMED BY A REFRIGERANT SPECIALIST.

WHEN REPAIRING THE REFRIGERANT CIRCUIT, COLLECT ALL THE REFRIGERANT IN A CONTAINER AND DISPOSE OF IT IN THE APPROPRIATE MANNER.

CHARACTERISTICS OF REFRIGERANT R134A

In normal temperature and pressure conditions the above refrigerant is a colorless, class A1/A1 gas with TVL value of 1000 ppm (ASHRAE classification).

If a refrigerant leak occurs, thoroughly air the room before commencing work.

TROUBLESHOOTING

TROUBLE	CAUSE	ACTION
Solenoid condensate valve will not close.	Debris in solenoid valve prevents diaphragm from seating.	Remove solenoid valve, disassemble, clean and reassemble.
	Short in electrical component.	Check and replace power cord or timer as needed.
Drain timer will not operate.	No electrical supply.	Apply power.
	Timer malfunction	Replace timer.
	Clogged port.	Clean valve.
	Solenoid valve malfunction.	Replace solenoid valve.
	Clogged strainer.	Clean strainer.

MAINTENANCE

Periodically clean the screen inside the valve to keep the drain functioning at maximum capacity. To do this, perform the following steps:

1. Close the strainer ball valve completely to isolate it from the air receiver tank.
2. Press the TEST button on the timer to vent the pressure remaining in the valve. Repeat until all pressure is removed.

CAUTION

High pressure air can cause injury from flying debris. Ensure the strainer ball valve is completely closed and pressure is released from the valve prior to cleaning.

3. Remove the plug from the strainer with a suitable wrench. If you hear air escaping from the cleaning port, STOP IMMEDIATELY and repeat steps 1 and 2.
4. Remove the stainless steel filter screen and clean it. Remove any debris that may be in the strainer body before replacing the filter screen.
5. Replace plug and tighten with wrench.
6. When putting the Electric Drain Valve back into service, press the TEST button to confirm proper function.

TROUBLE SHOOTING

PROBLEM	CAUSE	REMEDY
Compressor fails to start	Mains power or Control voltage not available.	<ul style="list-style-type: none"> § Check incoming power supply. § Check the control circuit fuse. § Check the transformer secondary windings for the control voltage.
	Defective Star / Delta timer.	§ Change Star / Delta timer.
Machine shuts down periodically	High airend temperature.	Top up coolant.
	Motor overload.	§ Set overload to correct value and switch to manual reset.
	Line voltage variation.	§ Ensure voltage does not drop below 10% on start up and 6% running.
High current draw	Compressor operating above rated pressure.	Set pressure to correct rating for machine.
	Separator cartridge contaminated.	Change air filter, and separator element.
	Low voltage.	§ Ensure voltage does not drop below 10% on start up and 6% running.
	Unbalanced voltage.	Correct incoming supply voltage.
	Damaged airend.	† Change Airend.
Low current draw	Air filter contaminated.	Change air filter.
	Compressor operating unloaded.	Set pressure to correct rating for machine.
	High voltage.	Reduce site voltage to correct operating voltage.
	Defective inlet valve.	† Fit inlet valve service kit.
High discharge pressure	Defective or incorrect pressure switch setting.	Replace or set pressure to correct rating for machine.
	Blowdown valve defective.	† Fit blowdown solenoid service kit.
	Inlet valve malfunction.	† Fit inlet valve service kit.
Low system air pressure	Separator cartridge contaminated.	Fit new Separator element.
	Incorrect pressure transducer setting	Set pressure to correct rating for machine.
	Minimum pressure valve malfunction.	† Fit Minimum pressure valve service kit.
	Blowdown valve defective.	† Fit blowdown solenoid service kit.
	Drive belt slipping.	Fit new belt.
	Air system leaks.	† Fix leaks.
	Inlet valve malfunction.	† Fit inlet valve service kit.
	System demand exceeds compressor delivery.	Reduce demand or install additional compressor.
	Compressed air filters contaminated.	Replace air filter elements.
High dewpoint	Refrigeration compressor not supplied power.	Check incoming power supply.
		Check the dryer protection fuse.
		Check auxiliary contact on main motor contactor.
	Condensate system malfunction.	Check operation of drain valve.
		Check operation of condensate check valves.
Condenser dirty.	Clean condenser and replace panel filter element.	
Ice formation in dryer	Low evaporator pressure.	Check hot gas valve setting.

PROBLEM	CAUSE	REMEDY
Compressor trips due to over temperature	Compressor operating above rated pressure.	Set pressure to correct rating for machine.
	Package pre-filter blocked.	Clean / replace package pre-filter.
	Cooler blocked.	Clean cooler.
	Missing or incorrectly fitted enclosure panels	Ensure that all enclosure panels are correctly fitted.
	Low coolant level.	Top up coolant and check for leaks.
	High ambient temperature.	Re-site compressor.
	Restricted cooling air flow.	Ensure correct air flow to compressor.
Excessive coolant consumption	Separator element leak.	Fit new Separator element.
	Blocked separator element drain.	† Remove fittings and clean.
	Compressor operating below rated pressure.	Set pressure to correct rating for machine.
	Coolant system leak.	† Fix leaks.
Excessive noise level	Air system leaks.	† Fix leaks.
	Airend defective.	† Change Airend.
	Belts Slipping.	Replace belt and tensioner.
	Motor defective.	† Replace motor.
	Loose components.	† Retighten loose items.
Shaft seal leaking	Defective shaft seal.	† Fit Airend shaft seal kit.
Pressure relief valve opens	Defective switch or incorrect pressure switch setting.	Replace or set pressure to correct rating for machine.
	Minimum pressure valve malfunction.	† Fit Minimum pressure valve service kit.
	Blowdown valve defective.	† Fit blowdown solenoid service kit.
	Inlet valve malfunction.	† Fit inlet valve service kit.
	Pressure relief valve defective.	Check the setting of the pressure relief valve and the rated pressure.
Black residue on belt guard/cooler box	Drive belt slipping.	Replace belt and tensioner.
	Pulleys misaligned.	Re-align pulleys.
	Worn pulleys.	† Replace pulleys and belt.
Safety valve blows when compressor goes on load	Minimum pressure valve stuck closed.	Strip minimum pressure valve, examine and repair if necessary.
	Safety valve faulty	Check the setting of the safety valve and the rated pressure.

NOTES:

- § Must be carried out by a competent electrician.
- † This work is recommended to be carried out only by an **Ingersoll Rand** authorized service technician.

CAUTION

LOW DEMAND APPLICATIONS

During periods of low demand, the compressor may not reach its normal operating temperature. Sustained operation at low demand can result in the build up of condensate in the coolant. If this situation occurs, the lubricating characteristics of the coolant can be impaired which may lead to damage of the compressor.

THE COMPRESSOR SHOULD BE ALLOWED AMPLE LOADED RUNNING TIME OF ATLEAST 10 MINUTES PER HOUR DURING NORMAL DAILY USE.

LOOK WHAT INGERSOLL RAND CAN DO FOR YOU!



Efficient Field Service

We maintain a highly trained staff of technicians to service your equipment for preventive maintenance, or to assist you should emergencies ever occur.



Complete Repair Service

Our trained technicians will repair or overhaul your equipment to factory specifications, using only genuine **Ingersoll Rand** parts.



Special Engineering Service

We can help you identify and solve your problems by evaluating your needs and recommending the proper equipment to give your maximum efficiency.



Spare Parts

By stocking genuine **Ingersoll Rand** spare parts, we can help you avoid costly delays or substituting inferior parts. Using genuine **Ingersoll Rand** parts on your **Ingersoll Rand** equipment will help to keep even older equipment running in good-as-new condition.



Complete Stock of Equipment

We carry a complete line of **Ingersoll Rand** equipment and accessories designed to meet any compressed air application. We are backed by **Ingersoll Rand's** prompt factory shipment to ensure you on-time delivery.

A SUBSTITUTE IS NOT A REPLACEMENT!

Ensure you get peak performance and longevity out of your **Ingersoll Rand** product by insisting on genuine **Ingersoll Rand** replacement parts and maintenance kits. Not only are the replacement parts made to precise dimensions and OEM-specified metallurgy, but each part is backed by the **Ingersoll Rand** warranty. Your local Customer Center, Distributor, or direct **Ingersoll Rand** salesperson will work with you to ensure you get the parts you need to do the job right. Equip your machines with only the best **Ingersoll Rand** genuine parts.

NOTE: THE USE OF REPAIR PARTS OTHER THAN THOSE INCLUDED WITHIN THE INGERSOLL RAND COMPANY APPROVED PARTS LIST MAY CREATE UNSAFE CONDITIONS OR MECHANICAL FAILURES OVER WHICH INGERSOLL RAND COMPANY HAS NO CONTROL. INGERSOLL RAND COMPANY SHALL BEAR NO RESPONSIBILITY FOR EQUIPMENT ON WHICH NON-APPROVED REPAIR PARTS ARE INSTALLED.

The manufacturer reserves the right to make changes or add improvements without notice and without incurring any obligation to make such changes to products previously sold.