

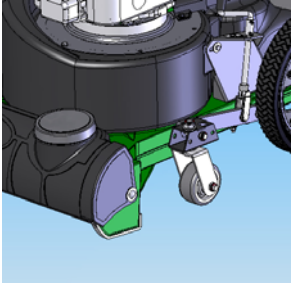

**BILLY GOAT[®] MV650SPH and MV600SPE
Self-Propelled Vacuum Owner's Manual**

Accessories

Caster Kit	Hose Kit	Bag Liner Kit	Felt Bag Kit
Use on hard surface for maneuverability.	For vacuuming hard to reach areas.	To collect leaves, thatch, and grass.	Use on all dusty conditions.
			
P/N 840129	P/N 840116	P/N 840134	P/N 840194

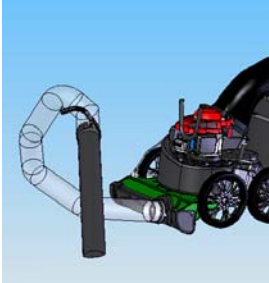

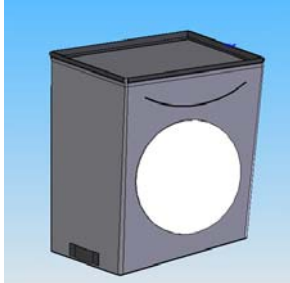
CONTENTS

Specifications and Sound/Vibration 3
Instruction Labels 4
Assembly Instructions 5-8
Operation 9-13
Maintenance and Troubleshooting 14-18
Illustrated Parts List 19-26

Go to <http://www.billygoat.com> for French-Canadian translations of the product manuals.
Visitez <http://www.billygoat.com> pour la version canadienne-française des manuels de produits



MV 650 SERIES SPECIFICATIONS

	MV650SPH	MV600SPE
Engine Type	Honda GSV190AA1A	Briggs and Stratton 122MO70110F1
Horsepower	6.5 (4.85 kW)	6.25 (4.66 kW)
Fuel Capacity	1.6 qt (1.5 L)	1qt (.9L)
Oil Capacity	0.58 qt (0.54L)	0.63 qt (0.59L)
Unit Weight	179 lbs (81.2 kg)	179 lbs (81.2 kg)
Shipping Weight	208 lbs (94.3 kg)	208 lbs (94.3 kg)
Overall Dimensions	28" Wide x 62.5" Long x 45.5" High	28" Wide x 62.5" Long x 45.5" High
Maximum Operating Slope	20°	20°
In compliance with 2000/14/EEC standards	103 dB(a) at 3320 rpm	103 dB(a) at 3320 rpm
Sound at operators ear	83 dB(a) at 3320 rpm	83 dB(a) at 3320 rpm

SOUND DATA



SOUND LEVEL 103 Dba at Operator Position

Sound tests were conducted in accordance with 2000/14/EC as well as ISO11094, and were performed on 5-17-2005 under the conditions listed below.

NOTE

Sound power level listed is the highest value for any model covered in this manual. Please refer to serial plate on the unit for the sound power level for your model.

General Conditions:	Sunny
Temperature:	66.2°F (19°C)
Wind Speed:	8.5 mph (13.7kph)
Wind Direction:	South Southwest
Humidity:	59%
Barometric Pressure:	29.9" Hg (101.35kPa)

VIBRATION DATA

VIBRATION LEVEL 1.43g(14.00m/s²)



Vibration levels at the operator's handles were measured in the vertical, lateral and longitudinal directions using calibrated vibration test equipment. Tests were performed on 5-24-2006 under the conditions listed below.

General Conditions:	Sunny
Temperature:	73.7°F (23.2°C)
Wind Speed:	8.05 mph (3.6m/s)
Wind Direction:	South
Humidity:	83.5%
Barometric Pressure:	29.91" Hg (101.31 kPa)



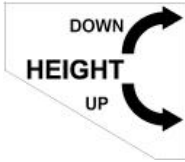

INSTRUCTION LABELS

The labels shown below were installed on your BILLY GOAT® MV Vacuum. If any labels are damaged or missing, replace them before operating this equipment. Item numbers from the Illustrated Parts List and part numbers are provided for convenience in ordering replacement labels. The correct position for each label may be determined by referring to the Figure and Item numbers shown.

 <p>PN 400268 (See Figure 3 Item 55)</p>	 <p>PN 890254 (See Figure 4 Item 162)</p>	 <p>PN 840054 (See Figure 1 Item 34)</p>
---	--	---

 <p>PN 400424 (See Figure 1 Item 11)</p>	 <p>PN 810736 (See Figure 4 Item 174)</p>	 <p>PN 890301 (See Figure 4 Item 163)</p>
---	--	--

 <p>PN 900327 (See Figure 2 Item 118)</p>	 <p>PN 840080 (See Figure 4 Item 175)</p>	 <p>PN 500176 (See Figure 2 Item 120)</p>
--	--	--

ENGINE LABELS



HONDA

CONTROLS



Throttle
P/N 840045

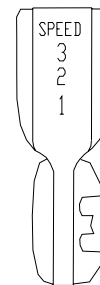

Drive
P/N 510127

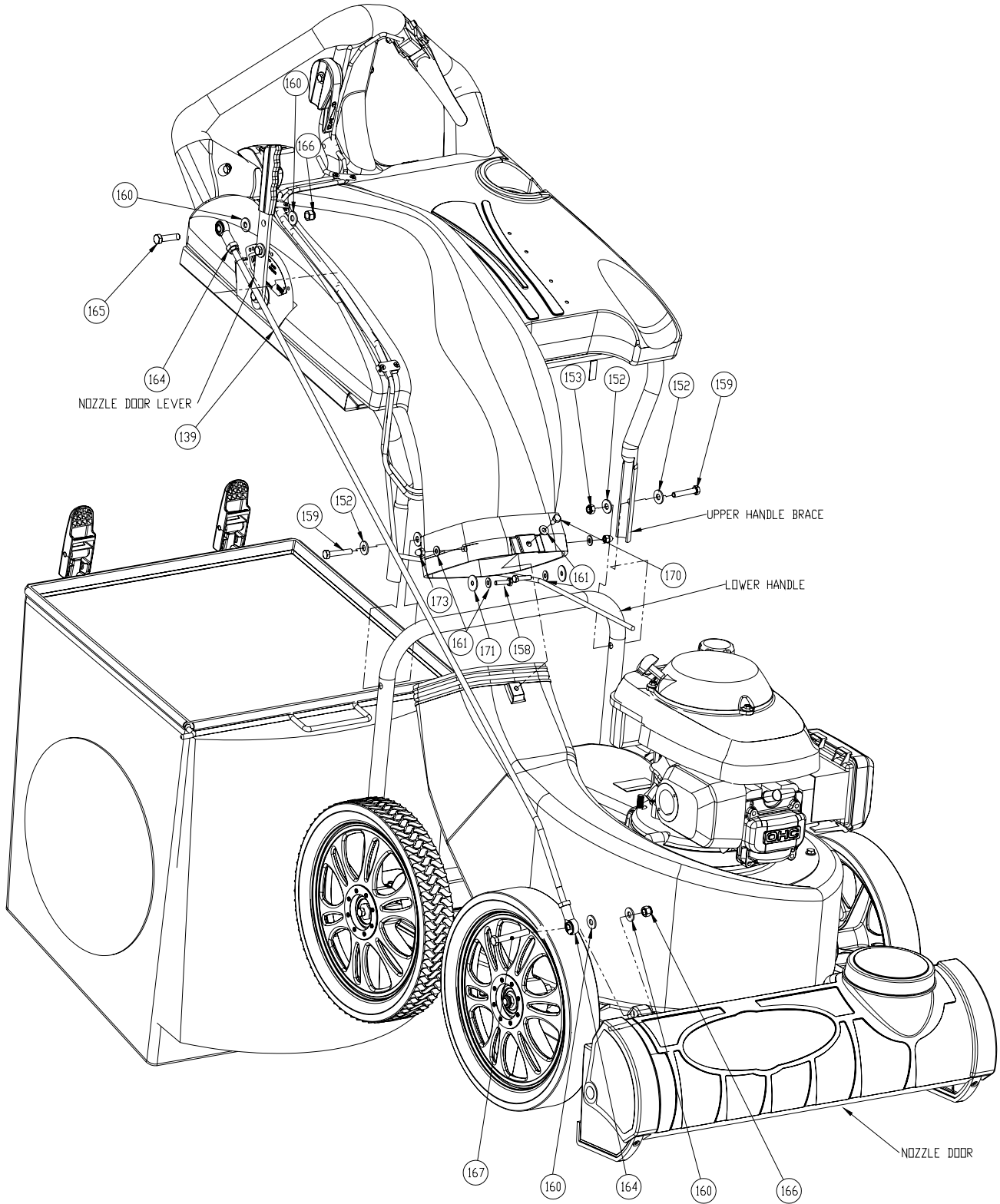

MV Vacuum Assembly Drawing

ASSEMBLY INSTRUCTIONS

Your BILLY GOAT® *MV Vacuum* was shipped in one carton, completely assembled except for the Hood/Upper Handle Assembly. Mounting hardware for the Hood/Upper Handle Assembly is temporarily installed on the lower handle and the Housing assembly.



READ all safety instructions before assembling unit.
TAKE CAUTION when removing the unit from the box since Hood/Upper Handle Assembly is attached to the unit by cables.

Remove unit from carton. Make sure the following items that have been packed with unit:

Parts bag P/N 840187

- Owner's Manual, P/N 840245
- General Safety and Warnings Manual, P/N 100294
- Declaration of Conformity, P/N 840204
- Honda Engine Manual
- Warranty Card, P/N 400972
- Ty-Wraps (2 ea)
- Hardware Bag



WARNING: **DISCONNECT** spark plug wire before assembling unit.

1. Attach hood assembly to the housing then hold in place during the step 2.

NOTE: BE SURE ALL CABLES ARE ROUTED ON THE UNDERSIDE OF THE HOOD AND HOUSING.

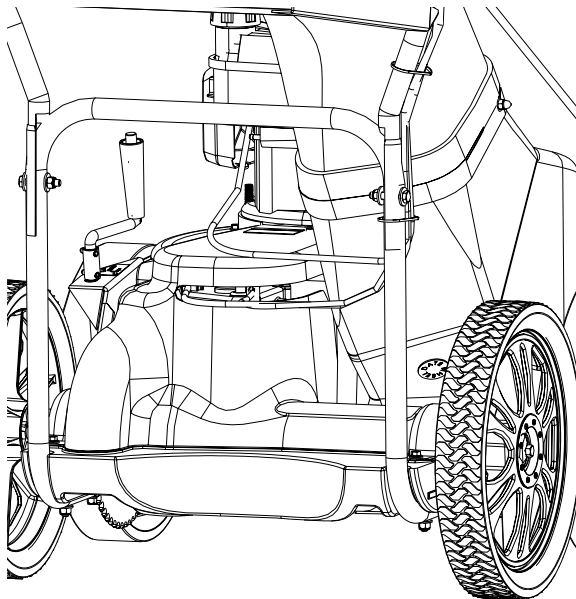

2. Install item #170 center bolt first when aligned with a nut on the housing.

3. Attach rest of hood assembly to the housing using corresponding hardware.

NOTE: You will have to insert the bolt/washer from the inside by reaching through the hood.

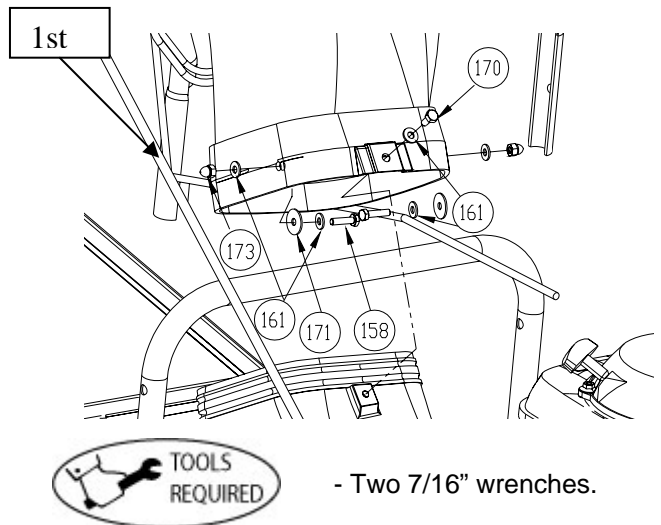



MV650SPH Self-Propelled Vacuum Owner's Manual

4. Attach upper handle brace to lower handle using corresponding hardware. Then repeat this step on the other side.

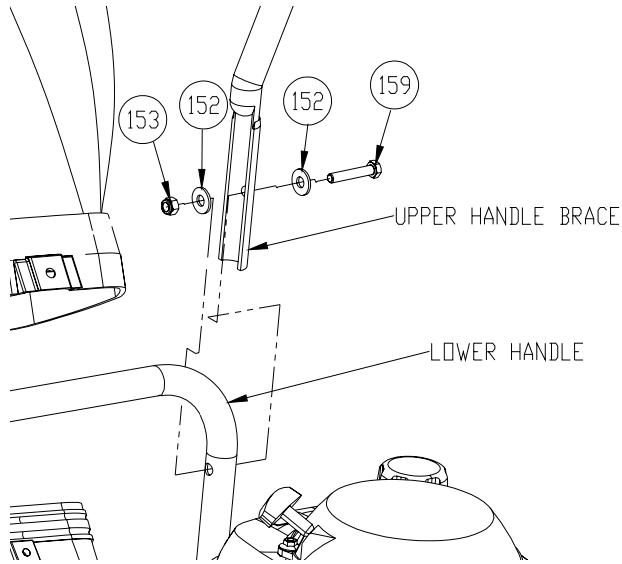

- Two 1/2" wrenches.

5. Attach rod end (164) to the nozzle door rod then secure in place by tightening jam nut.

6. Attach nozzle door rod to the nozzle door using corresponding hardware. **NOTE:** It is easier to do this with nozzle door closed.

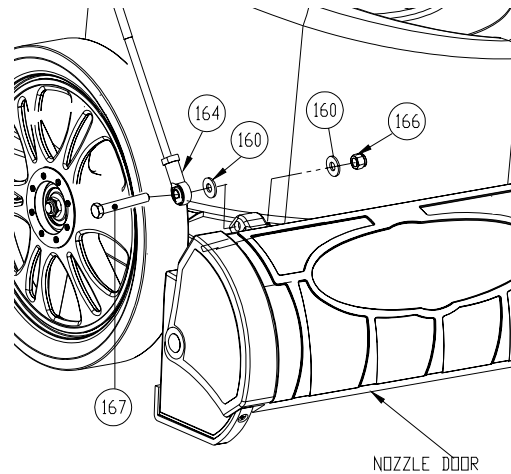

- Two 9/16" wrenches.

7. Attach rod end to rod (as in step 5).

8. Attach nozzle door rod to the lever with nozzle door closed and lever in hose kit position.

NOTE: Check to see nozzle door open and close all the way (see page 15). Tighten or loosen the rod end (164) for any adjustments.

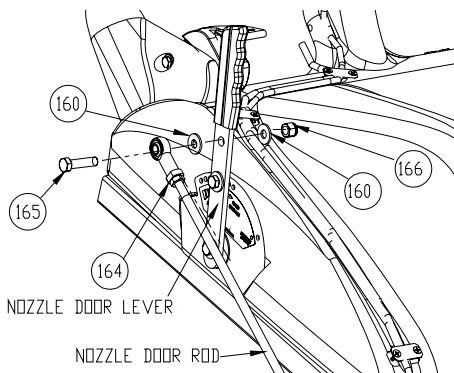

Two 9/16" wrenches.

9. Install cable ty wraps.

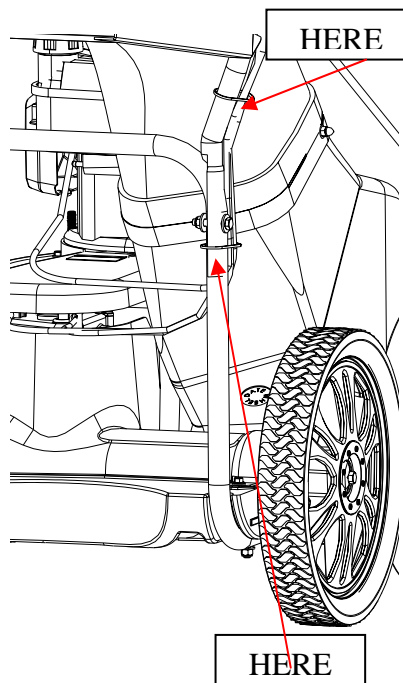

10. Reconnect spark plug wire.

11. Attach the bag.

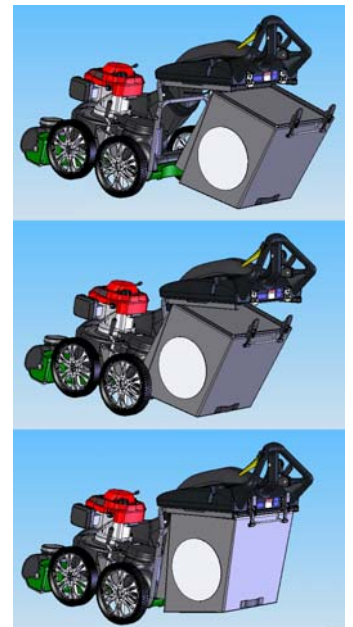

OPERATION

OPERATOR CONTROLS

The operator's position is at the rear of the machine between the handlebars. The operator should STAND in a position to allow both handlebars to be grasped firmly, which allows sufficient leverage to steer the machine. Operator's controls are shown below.

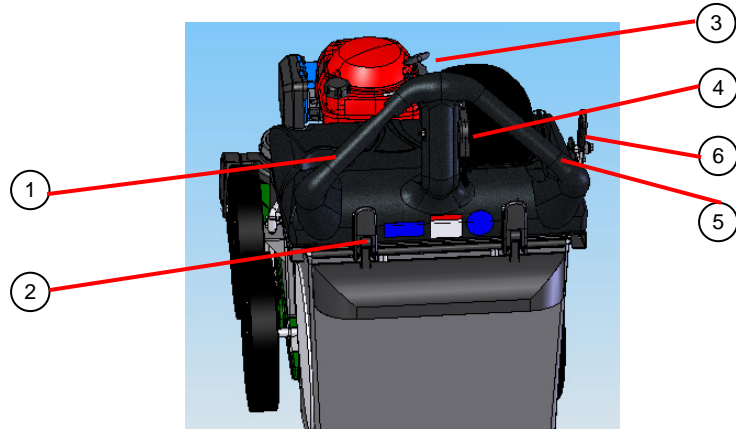

Operator Control Locations

- | | | | |
|---|--------------------|---|-----------------------|
| 1 | Drive Clutch Lever | 4 | Throttle Control |
| 2 | Bag Latch | 5 | Drive Shifter Control |
| 3 | Pull Starter | 6 | Nozzle Door Adjuster |

STARTING



CHECK engine oil level before operating machine.

1. Place equipment on a level, firm surface that is free of rocks or other debris.
2. Place throttle in START position.

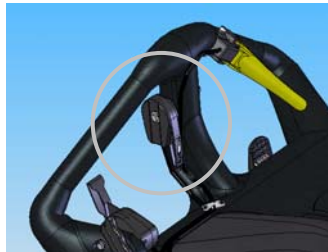

Throttle



WARNING: DO NOT START equipment without the debris bag in place.



MV650SPH Self-Propelled Vacuum Owner's Manual

- Secure the unit with left hand at the handle then pull starter rope with right hand to start engine.

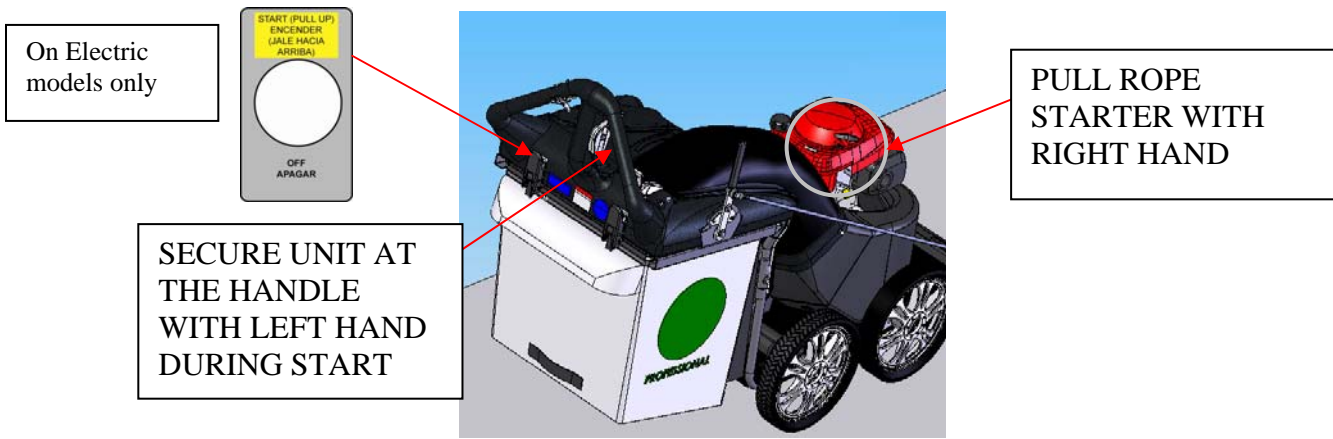

WARNING: PULL STARTER CORD slowly until resistance is felt. Then pull cord rapidly to avoid kickback.

- Move throttle control back to FAST position and allow engine to reach correct operating speed.
- For Electric models:** Set the throttle to the fast position, then pull up and push forward on the start switch. Choke if needed

VACUUM NOZZLE HEIGHT ADJUSTMENT

FOR MAXIMUM PICKUP: Adjust nozzle height as close to debris as possible, but without blocking airflow into the nozzle. **NOTE:** Never bury nozzle into debris. The vacuum nozzle is raised and lowered by turning the crank handle clockwise and counter-clockwise.

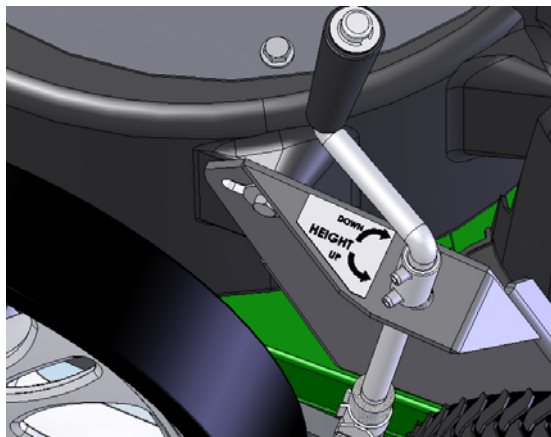

VACUUM NOZZLE DOOR ADJUSTMENT

The vacuum nozzle door adjusts for the maximum performance under various applications.

Nozzle fully opened. This is ideal for turf application

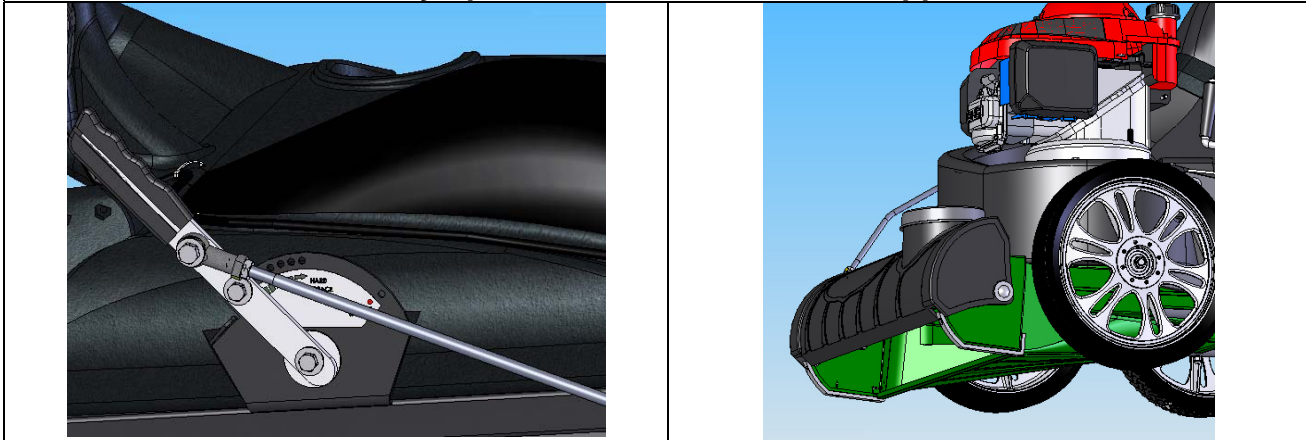

Nozzle half way opened. This is ideal for hard surface application

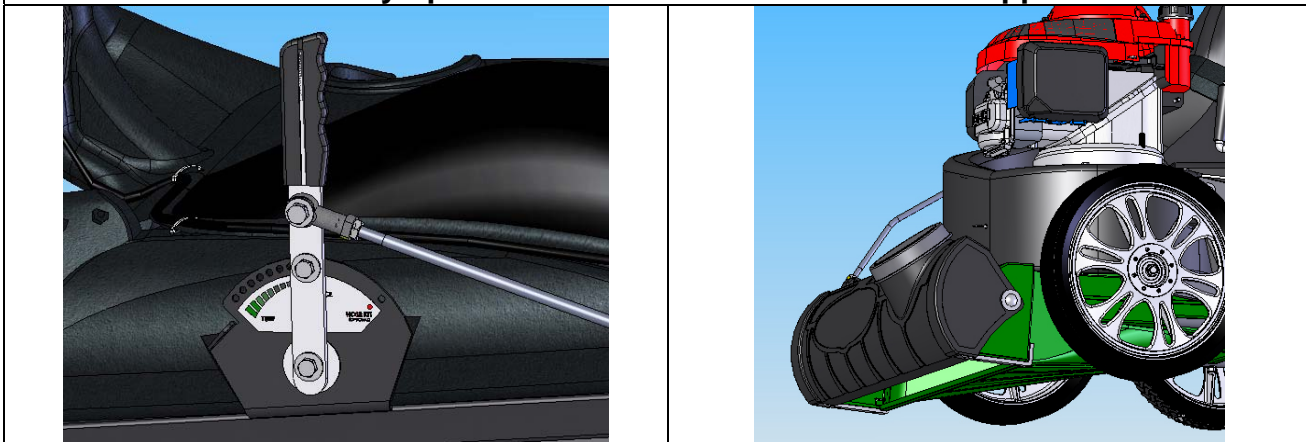

Nozzle closed for OPTIONAL hose kit. This is ideal for hard to reach places.

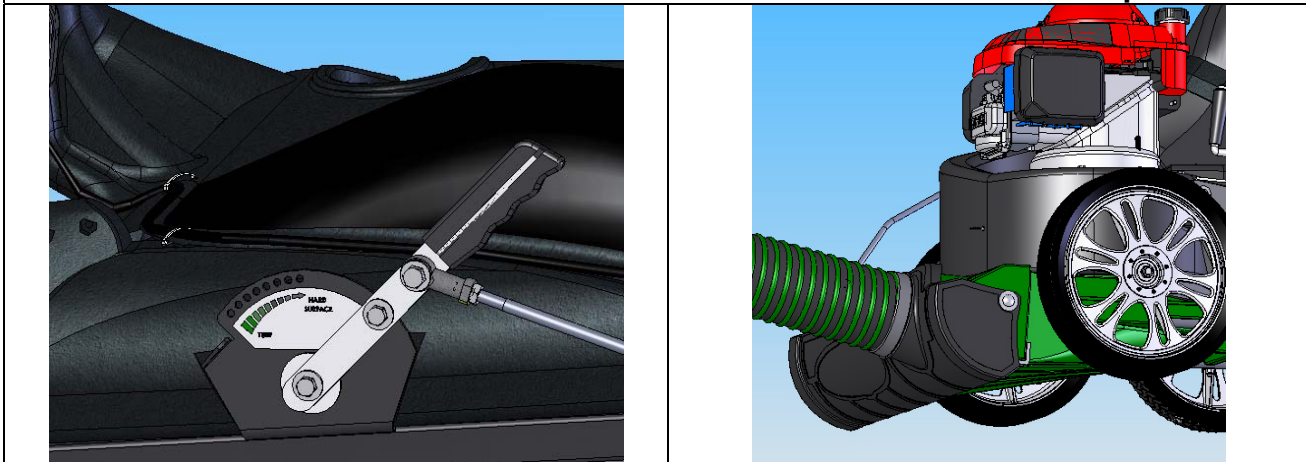



VACUUMING OPERATION

This machine is designed for vacuuming leaves, grass clippings, and other types of organic litter. Debris mixed with cans, bottles, and small amounts of sand can be vacuumed; however, it is not this machine's primary purpose. Vacuuming cans, bottles, and sand will affect the longevity of your machine. In dusty conditions it may be necessary to purchase Felt Bag Kit (P/N 840022).

Do not operate if excessive vibration occurs. If excessive vibration occurs, shut engine off immediately and check for damaged or worn impeller, loose impeller bolt, loose impeller key, loose engine or lodged foreign objects. Note: See parts list for proper impeller bolt torque specifications. (See trouble shooting section on page 23).

1. Move Shift Lever to correct position (1, 2, or 3) for desired gear.

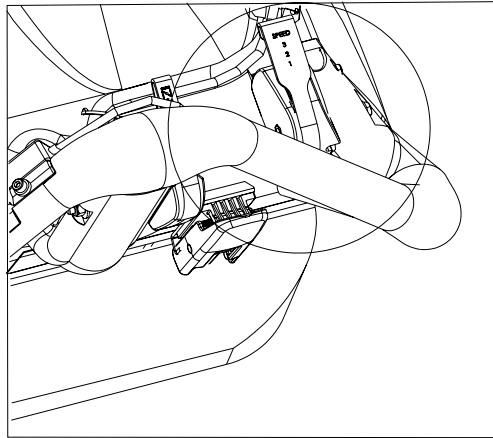

Gear Shift Lever

2. Squeeze the Drive Clutch lever against the handle to engage the drive.

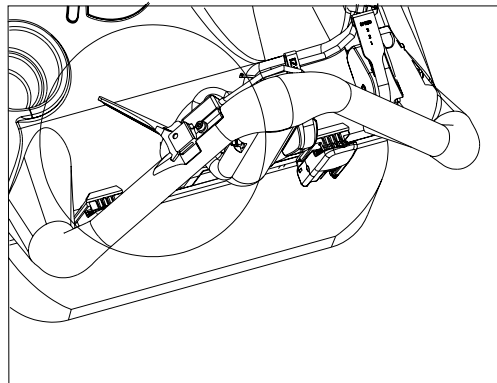

Drive Clutch Lever

SHUT DOWN

1. Release Drive Clutch Lever to disengage the drive.
2. Pull Throttle Control all the way back to the STOP position.



CLEARING A CLOGGED NOZZLE



WARNING: **DISCONNECT** spark plug wire before servicing unit.

1. Shut engine off and wait for impeller to stop completely.
2. Disconnect spark plug wire.
3. Wearing durable gloves, remove clog.



WEAR durable gloves. Clog may contain sharp materials.

4. Reconnect spark plug wire.

DEBRIS BAG

Debris bags are normal replaceable wear items.



WARNING: *Frequently empty debris to prevent bag overloading with more weight than you can lift.*

Bag liners are available for use in various conditions where debris will be vacuumed. (see Bag Liner Options shown on page 1).

DO NOT place bag on or near hot surface, such as engine.



WARNING: *Be sure engine has come to a complete stop before removing or emptying bag!!.*

This vacuum is designed for picking up trash, organic material and other similar debris (see Safety Warnings page 4-5).

Many vacuums are used where dust is mixed with trash. Your unit can intermittently vacuum in dusty areas.

However, following these rules will help maintain your machine's ability to vacuum in dusty conditions:

- Run machine at idle to quarter throttle.
- Machine or pressure-wash debris bag if normal cleaning does not fully clean bag. Bag should be thoroughly dry before use.

*Having one or more spare **Felt Filter** (840194) is a good way to reduce down time while dirty bags are being cleaned.*



MAINTENANCE

PERIODIC MAINTENANCE

Periodic maintenance should be performed at the following intervals:

Maintenance Operation	Every Use	Daily or Every 5 Hours	Every 25 Hours	Every 50 Hours	Every 100-150 Hours
Inspect for worn or damaged parts.	•				
Check for excessive vibration		•			
Inspect for loose parts.		•			
Clean Debris Bag	•				
Lubricate clutch control lever (Use white lithium grease or equiv.) LOCATION 1			•		
Lubricate height adjuster LOCATION 2			•		
Check drive clutch cable tension.				•	
Replace drive belts.					•

COMMON REPLACEMENT PARTS

- Bag. P/N 840189. Original equipment replacement bag.
- Skid. P/N 840041. Nozzle wear guard skid.
 - Drive Belt P/N 840066, Original equipment replacement belt

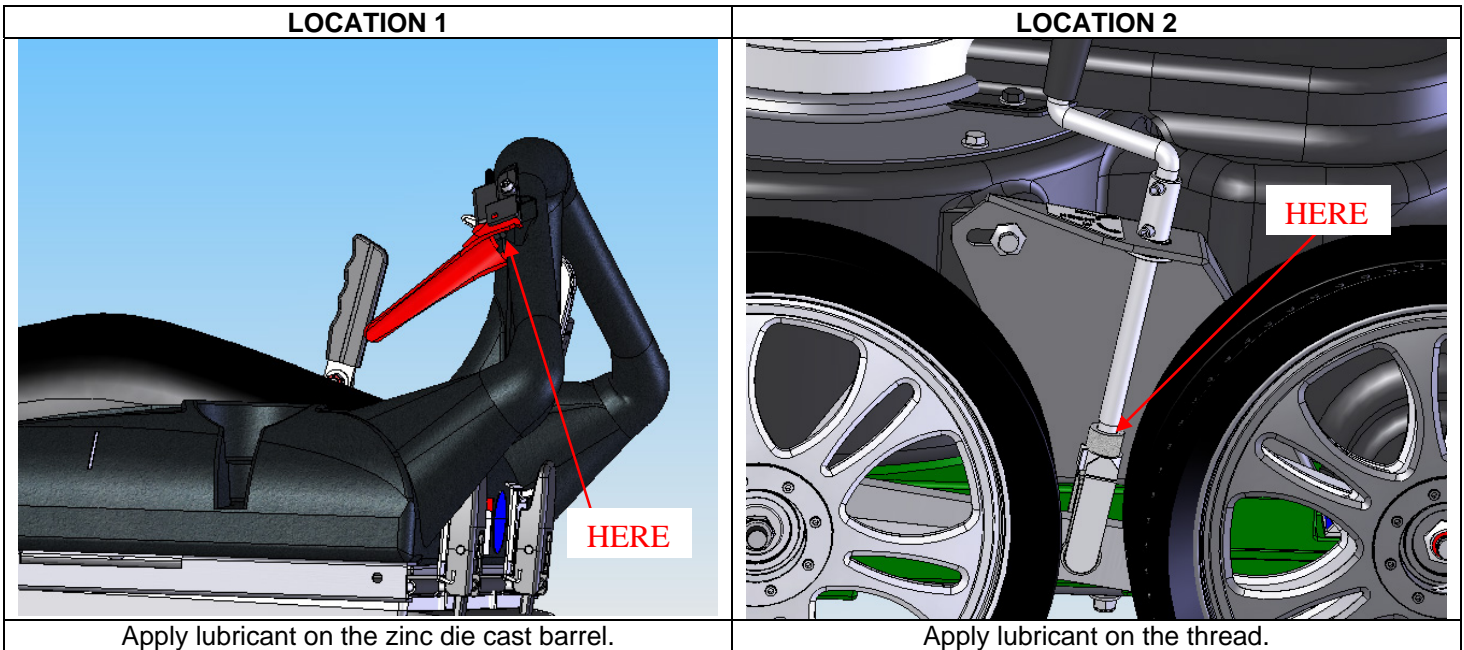



IMPELLER REMOVAL



READ all safety instructions before servicing unit.



WARNING: **DISCONNECT** spark plug wire before servicing unit.

Tools required:

- 1/2" socket, 3/8" drive
- ratchet, 3/8"
- drive extension, 3/8" drive
- universal joint, 3/8" drive
- pry bar or long screwdriver
- jack stands or similar device adequate to support weight of machine.

1. Wait for engine to cool and disconnect spark plug.
2. Drain fuel and oil from the engine.
3. Remove belt cover by removing 5 screws.
4. Detach drive belt from the transmission pulley by rotating the transmission assembly to relieve belt tension.
5. Remove engine, impeller and mounting plate by removing bolts around outside of housing.
6. Leaving engine fastened to plate, remove impeller bolt and lock washer and slide impeller off crankshaft (A puller may be required). **CAUTION:** Do not drop impeller.
7. If impeller does not slide off crankshaft, place two crowbars between impeller and housing on opposite sides. Pry impeller away from engine until it loosens. *Using a penetrating oil can help loosen a stuck impeller.*
8. If the impeller cannot be loosened, obtain a 1" (25.4mm) longer bolt of the same diameter and thread type as the impeller bolt. Invert engine and impeller and support engine above ground to prevent recoil damage. Thread longer bolt by hand into the crankshaft until bolt bottoms. Using a suitable gear or wheel puller against the bolt head and the impeller back-plate (near the blades), remove impeller from shaft.
9. To reinstall impeller, use a new impeller bolt and lockwasher
10. Tighten impeller bolt. Torque impeller bolt to 33-38 Ft. Lbs. (45-52 N.m).
11. Reinstall engine, impeller, and mounting plate onto housing in reverse order of removal.
12. Before connecting spark plug wire, slowly pull engine starting rope to insure that impeller rotates freely.
13. Reconnect spark plug wire.

DRIVE CLUTCH CABLE ADJUSTMENT



READ all safety instructions before servicing unit.



WARNING: **DISCONNECT** spark plug wire before servicing unit.

Tools required:

- Ratchet wrench with 6" extension and 3/8" socket.
- Two 10mm open end wrenches.
- Tape measure.



MV650SPH Self-Propelled Vacuum Owner's Manual

Procedure:

1. Wait for engine to cool and DISCONNECT SPARK PLUG!
2. Engage the clutch lever then pull the unit back until it stops freewheeling. The clutch lever should engage around 2 5/16" of travel or 4 inches from tip of lever to handle.
3. Tighten or loosen cable adjuster nut next to the clutch lever until drive engages at 4" from handle.
4. Holding the adjuster nut in place with one wrench tighten cable lock nut firmly.
5. Readjust as needed.
6. RECONNECT SPARK PLUG!
7. Test run unit to insure proper operation after this or any other maintenance procedure.
8. If clutch still will not engage at 4" from handle, remove guard retaining screws and guard.
9. Measure the amount of spring stretch. Spring should measure 1 1/8" when engaged (Lever 4" from handle).
10. Release clutch lever and then move it to engagement position again and hold it, check the spring length to assure it stayed in adjustment.
11. Re-install guard and fasteners.

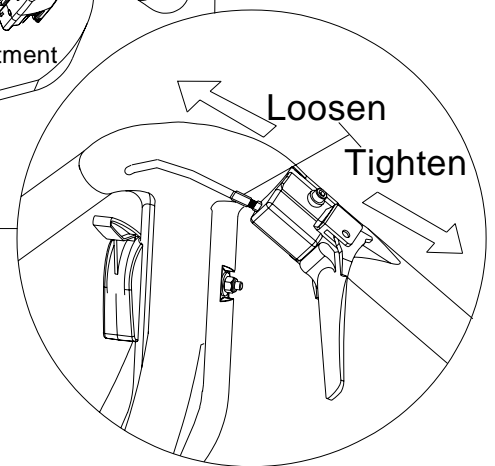
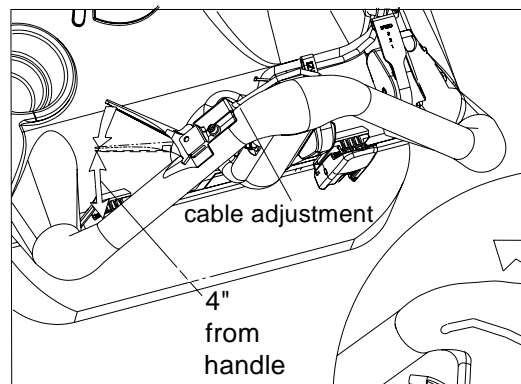
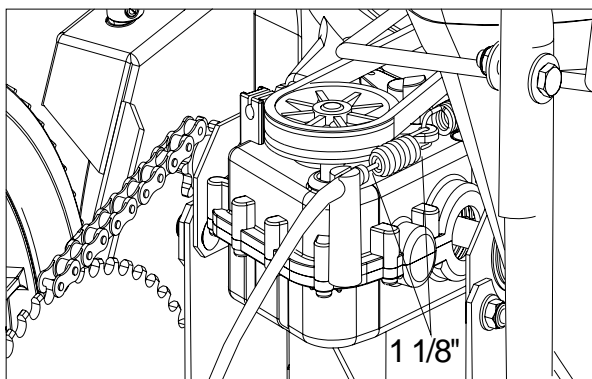

DRIVE BELT REMOVAL AND REPLACEMENT



READ all safety instructions before servicing unit.



WARNING: DISCONNECT spark plug wire before servicing unit.

Tools required:

- 3/8" drive ratchet
- 3/8" and 1/2" socket wrenches
- 3/8" and 5/16" wrench

Procedure:

1. Wait for engine to cool completely and DISCONNECT SPARK PLUG.
2. Remove guard fasteners and guard.
3. Remove throttle control cable from engine.
4. Unplug wiring harness wire at engine.
5. Tilt transmission input pulley toward engine and remove the belt from it upward.
6. Remove all six screws fastening the engine base plate to the housing.
7. Lift engine assembly from housing.
8. Slide belt inward under the engine and off downward around impeller.
9. Install new belt in reverse order of belt removal.
10. Note: before placing new belt on transmission pulley look under the engine to insure the belt is properly in the groove of the engine pulley.
11. Install engine assembly in reverse order of removal.
12. RECONNECT THE SPARK PLUG



INSTALLING NEW DRIVE CHAIN/ALIGNMENT/TENSION



READ all safety instructions before servicing unit.



WARNING: **DISCONNECT** spark plug wire before servicing unit.

Tools required:

- 7/16" and 1/2" socket.
- 7/16" and 1/2" combination wrench.
- "Needle nose" pliers
- Flat head screwdriver

Allow the engine to cool completely and **DISCONNECT THE SPARK PLUG**.

1. Unfasten and remove the guard.
2. Rotate left rear wheel to bring the chain "master link" into view on the axle sprocket.
3. Using the needle nose pliers carefully remove master link retaining spring clip.
4. Slide the master link from the chain and remove the chain.
5. Thread the new chain onto the sprockets, place the ends of the chain on the axle sprocket, this makes it easier to hold the chain in place when you slide the new master link in place.
6. Install the new master link and **CAREFULLY** install the retaining clip.
7. Rotate left rear wheel to find the location where the chain is tightest (there are always slight variations in the sprockets that make the chain tighter at places in its rotation).
8. Rotate the axle several times and listen for "popping" or "clacking" this indicates too much tension on the chain or misalignment of the chain. Skip to Step 12 if no "popping" or "crackling" occurs.

Improper Chain Tension

9. At the point where the chain is tightest check the chain to for 1/4" to 1/2" total slack halfway between the axle sprocket and the transmission sprocket. Skip to Step 11 if the deflection is correct.
10. Loosen 4 nuts holding the bearing bracket (see Fig 1) slide it very slightly forward to tighten the chain or slide backward to loosen. Tighten 4 nuts back then check the chain deflection. Repeat this step if necessary.

Improper Chain Alignment

11. Loosen 5 bolts securing the drive system (see Fig 2) slide it left or right then check the alignment using straight edge. Tighten 5 bolts then repeat Step 8.
12. Reinstall the guard and all of its fasteners.
13. **RECONNECT THE SPARK PLUG**.

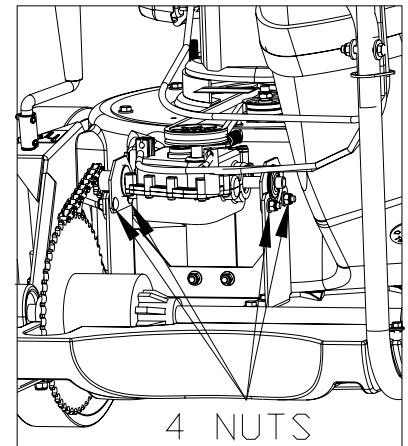

Fig 1

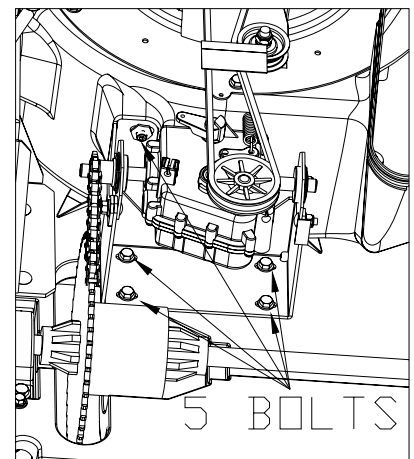
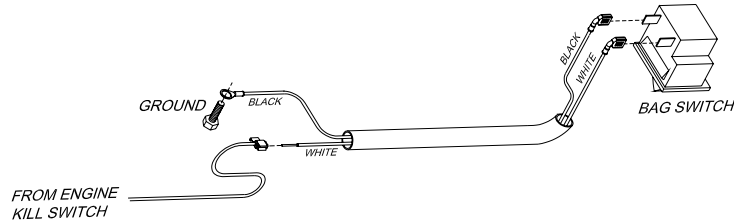

Fig 2



MV650SPH Self-Propelled Vacuum Owner's Manual

WIRING DIAGRAMS



Bag Switch Circuit Schematic Diagram

TROUBLESHOOTING

Problem	Possible Cause	Solution
Will not vacuum or has poor vacuum performance.	<ul style="list-style-type: none"> · Dirty or full debris bag or filter. · Nozzle height set too high or too low. · Hose kit cap missing. · Clogged nozzle or exhaust. · Excessive quantity of debris. 	<ul style="list-style-type: none"> · Clean debris bag and filter. Shake bag clean or wash. · Adjust nozzle height (see page 14). · Check for hose kit cap. · Unclog nozzle or exhaust (see page 5) · Allow air to feed with debris.
Abnormal vibration.	<ul style="list-style-type: none"> · Loose or out of balance impeller. · Loose engine. 	<ul style="list-style-type: none"> · Check impeller and replace if required. · Check engine.
Engine will not start.	<ul style="list-style-type: none"> · Throttle in off position. · Engine not in full choke position. · Out of gasoline or bad, old gasoline. · Spark Plug wire disconnected. · Gas valve off. · Dirty air cleaner. · Safety Interlock disengaged on bag plate. 	<ul style="list-style-type: none"> · Check throttle control (see page 13). · Check throttle, choke position (see page 13). · Check gasoline. · Connect spark plug wire. · Turn on gas valve. · Clean or replace air cleaner. Contact a qualified service person. · Latch the bag properly or check the bag rod to see if it is bent.
Engine is locked, will not pull over.	<ul style="list-style-type: none"> · Impeller plugged or clogged. · Engine problem. 	<ul style="list-style-type: none"> · Remove debris (see page 16). · Contact an engine servicing dealer for engine problems.
No self-propelling	<ul style="list-style-type: none"> · Drive clutch not engaged · Transmission not in gear. · Drive belt worn or broken · Drive clutch cable out of adjustment or broken. · Spring tension too loose · Drive chain off the sprocket. 	<ul style="list-style-type: none"> · Engage the drive clutch lever. · Check transmission shift control (see page 16). · Check the drive belt. · Check the drive clutch cable (see page 20). · Check spring length (see page 20). · Check the drive chain (see page 22).
Self propelled drive will not release	<ul style="list-style-type: none"> · Improper drive clutch cable adjustment or cable is kinked. 	<ul style="list-style-type: none"> · Check the drive clutch cable (see page 20).
Noisy or broken chain	<ul style="list-style-type: none"> · No chain lubrication. · Chain misalignment or tension. 	<ul style="list-style-type: none"> · Lubricate chain. · Check the drive chain (see page 22).

ILLUSTRATED PARTS LIST

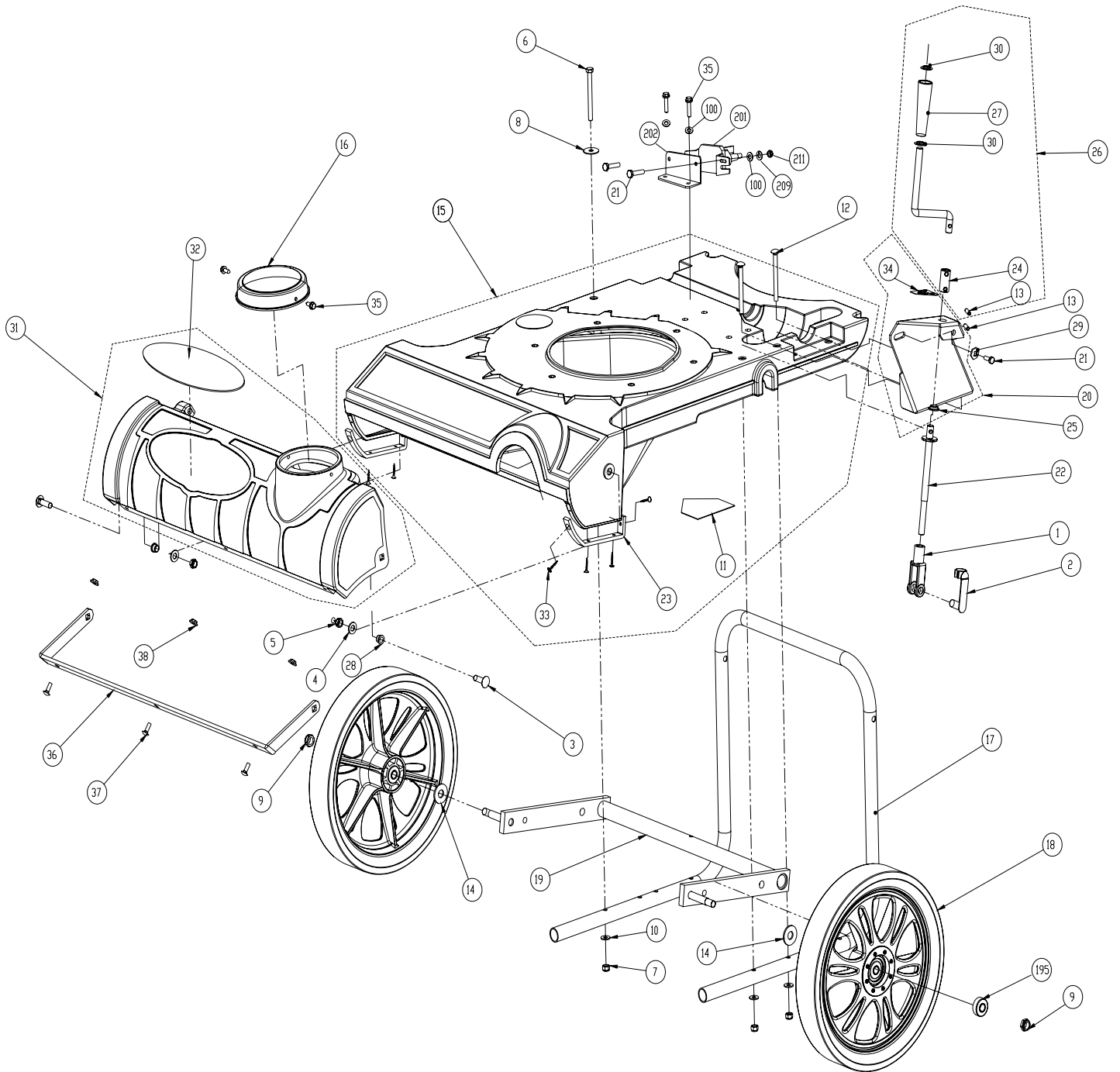

Nozzle Assembly
Figure 1



MV650SPH Self-Propelled Vacuum Owner's Manual

Nozzle Assembly Parts List

ITEM NO.	PART NUMBER	DESCRIPTION	MV650SPH QTY.	MV600SPE QTY.
1	350127	YOKE 1/2 - 20	1	1
2	350128	PIN YOKE 1/2"	1	1
3	8024060	BOLT CARRIAGE 3/8-16X1 1/2" ZP	2	2
4	8172009	WASHER 3/8" SAE ZP	2	2
5	8161042	NUT LOCK 3/8-16 LT WT THIN ZP	2	2
6	8041038	SCREWCAP 5/16 -18 x 3 1/2	1	1
7	8160002	NYLON INSERT LOCKNUT 5/16-18 UNC	3	3
8	8172020	WASHER FLAT FENDER 5/16	1	1
9	8161044	NYLON INSERT LOCKNUT 1/2-13 UNC THIN	2	2
10	8171002	WASHER 1/4" FC ZP	3	3
11	400424	LABEL WARNING OPEI	1	1
12	8024050	BOLTCARRIAGE 5\16-18X3 1\2	2	2
13	520156	ROLL PIN 1/4 X 1 LONG	2	2
14	8172011	WASHER 1/2" SAE ZP	2	2
15	840118	NOZZLE MV VAC ASSEMBLY	1	1
16	840019	CAP 5 IN HOSE VAC	1	1
17	840024	HANDLE LOWER MV VAC	1	1
18	840101	WHEEL 14" ASSEMBLY WITH BEARING AND TIRE	2	2
19	840104	AXLE FRONT WA MV VAC	1	1
20	840155	BRACKET HGT ADJ WA W/LABEL MV VAC	1	1
21	8041004	SCREWCAP 1/4 - 20 x 0.75 HWH	1	3
22	840034	LINK HGT ADJ MV VAC	1	1
23	840041	BRACKET NOZZLE WEAR GUARD MV VAC	2	2
24	840029	ROD CONNECT HGT ADJ	1	1
25	840073	BUSHING 0.5" ID 0.625 OD X X 0.250	1	1
26	840119	ROD HANDLE CRANK ASSEMBLY	1	1
27	840057	HANDLE CRANK 0.5 ID X 3.72 LONG	1	1
28	840078	BUSHING 3/8" ID 1/2" OD X 3/8" LONG	2	2
29	840158	WASHER LOCK 1/4" TWISTED TOOTH	1	1
30	840207	NUT PAL 0.5" ID x 0.75 OD	2	2
31	840135	NOZZLE COVER MV VAC	1	1
32	840055	LABEL PRODUCT DECAL MV	1	1
33	840035	SCREW PLASTIC 5/8	8	8
34	840054	LABEL HGT ADJ MV VAC	1	1
35	8122082	SCREW SELF-TAP 5/16 NC X 3/4 HEX	2	4
36	840088	BRACKET NOZZLE COVER REINFORMENT MV	1	1
37	8024021	BOLT CARRIAGE 1/4-20X0.75	3	3
38	900455	NUT FLANGE 1/4-20	3	3
100	8172007	WASHER 1/4" SAE ZP	-	4
195	840017	MV WHEEL BEARING	2	2
201	840117	SOLENOID ELEC START	-	1
202	840198	BRACKET SOLENOID MOUNT MV	-	1
209	8181007	WASHER LOCK 1/4" EXT TOOTH	-	2
211	8142001	NUT 1/4" FIN HEX ZP	-	2

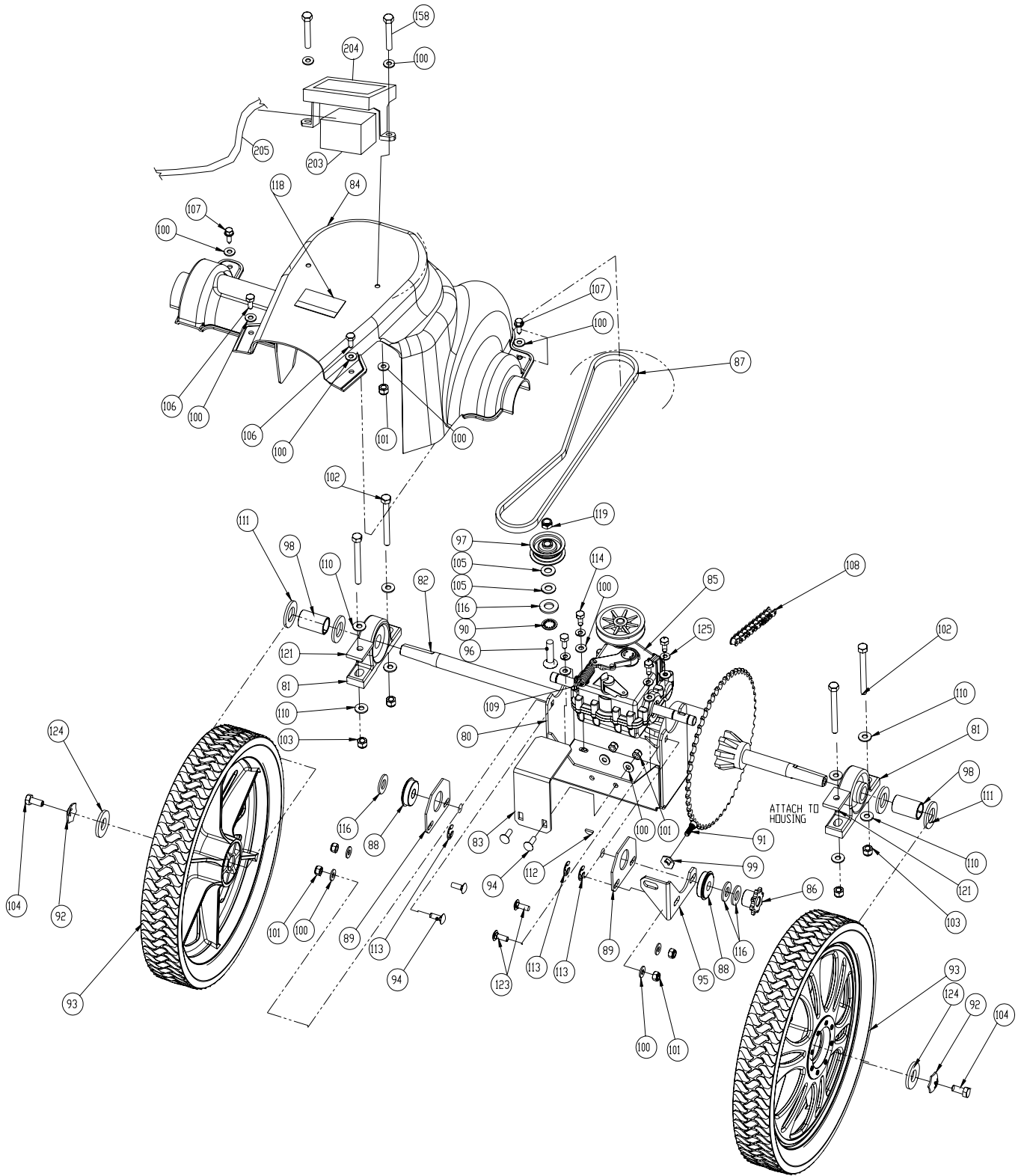

Drive /Rear Axle Assembly
Figure 2



MV650SPH Self-Propelled Vacuum Owner's Manual

Drive /Rear Axle Assembly Parts List

ITEM NO.	PART NUMBER	DESCRIPTION	MV650SPH QTY.	MV600SPE QTY.
80	840110	BRACKET TRANS MOUNT WA MV VAC	1	1
81	350133	BEARING 3/4" W/PILLOW BLOCK	2	2
82	840009	DIFFERENTIAL 54 TOOTH D-CUT	1	1
83	840086	BRACKET TRANS ANTI ROTATION MV	1	1
84	840010	GUARD DRIVE SP VAC	1	1
85	840085	TRANSMISSION 3 SPD GENERAL TRANS.	1	1
86	510126	SPROCKET 8 TOOTH	1	1
87	840066	BELT 3L34	1	1
88	510125	BEARING 1/2" CLIP	2	2
89	840011	PLATE TRANS BEARING MOUNT MV VAC	2	2
90	520025	WASHER LOCK INTERNAL TOOTH 1/2"	1	1
91	8041004	1/4 - 20 x 0.75 HWH	1	1
92	430298	WASHER 5/16 LOCK TWISTED TOOTH	2	2
93	840102	WHEEL 14" ASSEMBLY DRIVE MV VAC	2	2
94	8024021	BOLT CARRIAGE 1/4-20X0.75	4	4
95	840028	BRACKET TRANS REINFORCE MV VAC	1	1
96	8024060	CARRIAGE BOLT 3/8 - 16 X 1 1/2	1	1
97	840087	PULLEY IDLER 2" OD X 3/8" ID	1	1
98	840027	TUBE 0.75 ID WHEEL SPACER SP MV VAC	1	1
99	840158	WASHER LOCK 1/4 TWISTED TOOTH	1	1
100	8172007	WASHER 1/4" SAE ZP	14	14
101	8160001	NYLON INSERT LOCKNUT 1/4-20 UNC	6	6
102	8041036	SCREWCAP 5/16"-18X3" HCS ZP	4	4
103	8160002	NYLON INSERT LOCKNUT 5/16-18 UNC	4	4
104	8041026	SCREWCAP 5/16"-18 X 3/4" LONG ZP	2	2
105	8172009	WASHER 3/8" SAE ZP	2	2
106	890359	1/4 - 20 x 5/8 HWH	2	2
107	8122082	SCREW SELF-TAP 5/16 NC X 3/4 HEX	2	2
108	840072	CHAIN #41 X 42 PITCH	1	1
109	800242	SPRING TENSION	1	1
110	8171002	WASHER 1/4" FC ZP	8	8
111	8172015	WASHER 3/4" SAE ZP	2-6	2-6
112	510180	WOODRUFF KEY 1/8 X 1/2	1	1
113	350146	CLIP 1/2"	3	3
114	840213	SCREWCAP 1/4-20 X 5/8 GR. 5	4	4
115				
116	8171006	WASHER 1/2" FLAT CUT	3	3
117				
118	900327	LABEL DANGER GUARD	1	1
119	8161042	NUT LOCK 3/8-16 LT WT THIN ZP	1	1
120				
121	840188	BRACKET BEARING FIX	2	2
122				
123	8041022	CARRIAGE BOLT 1/4 - 20 X 1 ZP	2	2
124	8172020	WASHER FENDER 5/16	2	2
125	8177010	SPLIT LOCK WASHER 1/4"	4	4
158	8041006	SCREWCAP 1/4"-20 X 1" HCS ZP	-	2
195	840017	MV WHEEL BEARING	2	2
203	804170	BATTERY 12 V	-	1
204	840095	BATTER HOLD DOWN	-	1
205	840228	CABLE HARNES ELECTRIC START ONE PIECE	-	1

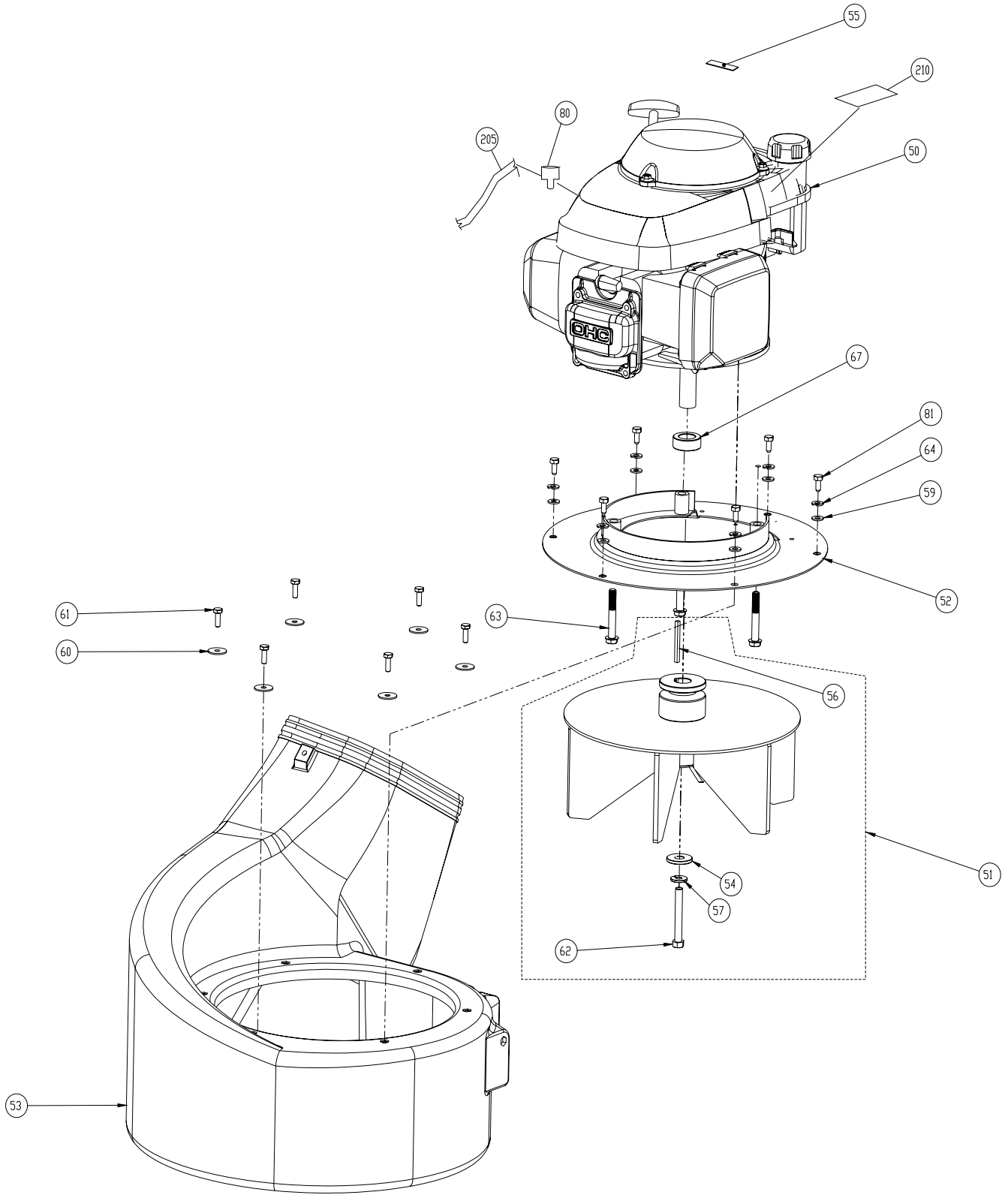

Engine Assembly
Figure 3



MV650SPH Self-Propelled Vacuum Owner's Manual

Engine Assembly Parts List

ITEM NO.	PART NUMBER	DESCRIPTION	MV650SPH QTY.	MV600SPE QTY.
50	840069	ENGINE HONDA 6.5 VERTICAL GSV190	1	1
51	840136	IMPELLER ASSEMBLY SP MV VAC	1	1
52	840107	PLATE TOP WA SP MV VAC	1	1
53	840205	HOUSING PLASTIC VAC	1	1
54	440153	WASHER 1.5 OD X .453 ID X .25 THK	1	1
55				
56	9201087	SQ KEY 2.125 X .187	1	1
57	8177012	WASHER LOCK 3/8" ST MED	1	1
58				
59	8172007	WASHER 1/4" SAE ZP	6	6
60	8172019	WASHER FENDER 1/4 ZP	6	6
61	8041004	SCREWCAP 1/4 - 20 x 0.75 HWH	6	6
62	790167	SCREWCAP 3/8-24X2 3/4" W/PATCH LOCK	1	1
63	900564	SCREWCAP 3/8"-16X2 1/2" TAPTITE	3	3
64	8177010	WASHER SPLIT LOCK 1/4"	6	6
65				
66				
67	840083	SPACER 1.50OD X .890ID X .5 THK	1	1
80	840215	TERMINAL 18-14 BLUE T-TAP	1	1
81	840213	SCREWCAP 1/4-20X5/8 GR. 5	6	6
205	840228	CABLE HARNESS ELECT START	-	1
210	100261	LABEL WARNING FUEL EN/SP	-	1

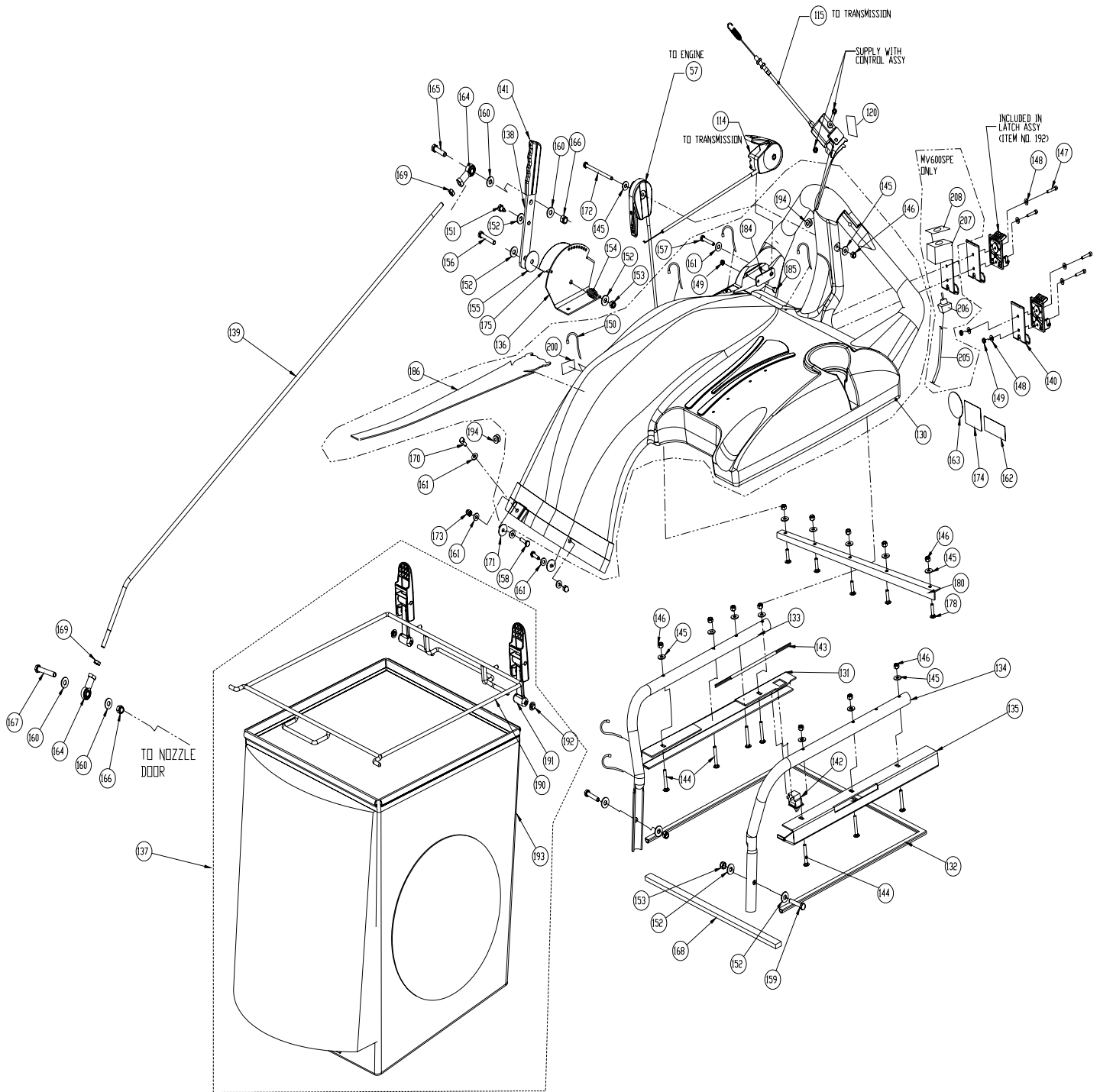

Hood Assembly
Figure 4



MV650SPH Self-Propelled Vacuum Owner's Manual

Hood Assembly

ITEM NO.	PART NUMBER	DESCRIPTION	MV650SPH QTY.	MV600SPE QTY.
57	840045	CONTROL THROTTLE WESCON MV VAC	1	1
114	840023	CONTROL SHIFT WESCON MV VAC	1	1
115	840063	CONTOL LEVER ASSY CLUTCH SP VAC	1	1
120	500176	LABEL CLUTCH DRIVE	1	1
130	840141	HOOD ASSY W/ LABEL MV VAC	1	1
131	840153	BRACKET BAG CHANNEL RH W/SEAL MV VAC	1	1
132	840196	SEAL BAG MV VAC	1	1
133	840037	TUBE HANDLE BRACE RH MV VAC	1	1
134	840038	TUBE HANDLE BRACE LH MV VAC	1	1
135	840154	BRACKET BAG CHANNEL RH W/SEAL MV VAC	1	1
136	840152	BRACKET NOZZLE DOOR ADJ W/LABEL MV VAC	1	1
137	840195	BAG ASSEMBLY MV VAC	1	1
138	840138	BAR LIFT NOZZLE DOOR W/ GRIP MV VAC	1	1
139	840061	ROD LIFT NOZZLE DOOR SP VAC	1	1
140	840062	PLATE BAG LATCH MV VAC	2	2
141	840191	GRIP LEVER LIFT	1	1
142	840058	SWITCH INTERLOCK VAC	1	1
143	840077	HARNNESS WIRE ASSY MV VAC	1	1
144	8024025	BOLT CARRIAGE 1/4-20 X 1.75	7	7
145	8171002	WASHER 1/4" FC ZP	14	14
146	8160001	NYLON INSERT LOCKNUT 1/4-20 UNC	13	13
147	520018	SCREW HEX HEAD #10-24 X 1"	4	4
148	8172005	WASHER #10 SAE ZP	8	8
149	8164005	NYLON INSERT LOCKNUT 10-24 UNC	4	4
150	900407	Ty-Wrap	6	6
151	610347	PIN SCREW 1/4-28	1	1
152	8171003	WASHER 5/16 FLATWASHER ZP	7	7
153	8160002	NYLON INSERT LOCKNUT 5/16-18 UNC	3	3
154	610429	SPRING LEVER GZ	1	1
155	610348	FIBRE WASHER	1	1
156	8041032	SCREWCAP 1/4-20X2"	1	1
157	8041011	SCREWCAP 1/4"-20X2 1/4" ZP	1	1
158	8041006	SCREWCAP 1/4-20X1" ZP	2	2
159	8041031	SCREWCAP 5/16-18 X 1.75 ZP	2	2
160	8171004	WASHER 3/8 FC	4	4
161	8172007	WASHER 1/4" SAE ZP	6	6
162	890254	LABEL EAR EYE BREATHING	1	1
163	890301	LABEL READ	1	1
164	400886	ROD END BALL JOINT 3/8 NF	2	2
165	8041052	SCREW CAP 3/8-16X1 1/2 ZP	1	1
166	8160003	NYLON INSERT LOCKNUT 3/8-16 UNC	2	2
167	8041056	SCREWCAP 3/8"-16X2 1/2" ZP	1	1
168	840197	SEAL BAG FRONT HOOD 20.5 LONG	1	1
169	8149003	NUT REG 3/8-24 NF	2	2
170	8041004	SCREWCAP 1/4"-20X3/4" HCS ZP	1	1
171	8172019	WASHER FENDER 1/4 ZP	2	2
172	8041018	SCREWCAP 1/4"-20X4" HCS ZP	1	1
173	840071	NUT ACORN 1/4-20	2	2
174	810736	LABEL DANGER FLYING DEBRIS	1	1
175	840080	LABEL NOZZLE DOOR MV VAC	1	1
178	8024021	BOLT CARRIAGE 1/4-20 X 3/4"	5	5
180	840214	BRACKET HOOD FRONT STRAIGHTENER	1	1
184	840180	PLATE SHIFT CONTROL ANTI ROT	1	1
185	8059140	SCREWCAP #10-24X1 1/4"	1	1
186	840179	LABEL HOOD DECAL	1	1
190	840040	ROD BAG WA MV VAC	1	1
191	840139	LATCH RUBBER ASSEMBLY MV VAC	2	2
192	360203	PAL NUT 0.312	2	2
193	840189	BAG DEBRIS MV VAC	1	1
194	840206	GROMMET RUBBER 5/8" OD X 3/8" ID	2	2
200	520116	LABEL MADE IN U.S.A.	1	1
205	840228	CABLE HARNESS ELECT START	-	1
206	500307	SWITCH	-	1
207	840096	BRACKET START SWITCH MV VAC	-	1
208	100262	LABEL START STOP EN/SP	-	1