

*Operator's Manual*

# **SNAPPER<sup>®</sup>**

**REAR ENGINE RIDING MOWER**

**SERIES 24**

*Model No. Description*

7800784	2811524BV
7800785	2812524BVE
7800786	3014524BVE
7800787	3317524BVE

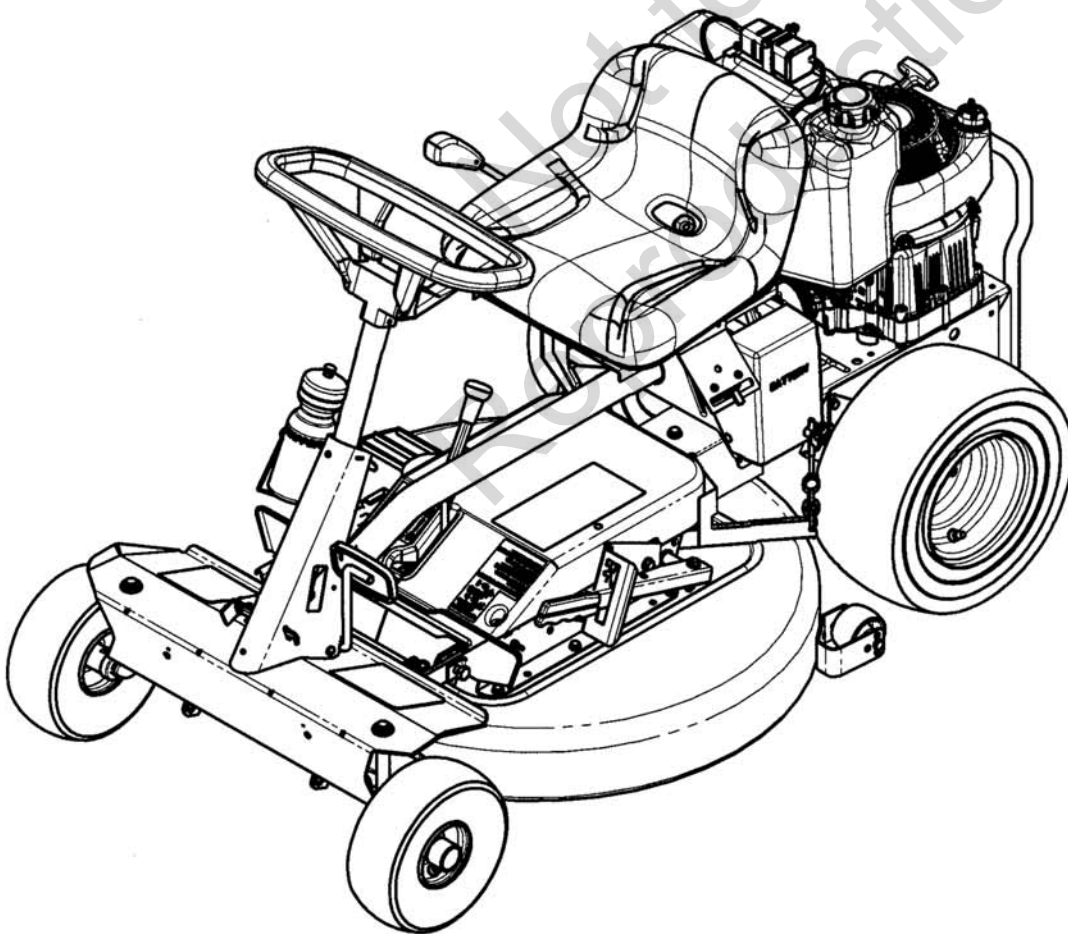

**Thank You** for purchasing this quality-built Snapper product. We're pleased that you placed your confidence in the Snapper brand. When operated and maintained according to the instructions in this manual, your Snapper product will provide many years of dependable service.

**This manual contains** safety information to make you aware of the hazards and risks associated with the machine and how to avoid them. This machine is designed and intended only for finish cutting of established lawns and is not intended for any other purpose. It is important that you read and understand these instructions thoroughly before attempting to start or operate this equipment. **Save these original instructions for future reference.**

**Complete the following information on your purchase.**

**Date of Purchase** \_\_\_\_\_

**Retailer** \_\_\_\_\_

**Retailer's Phone Number** \_\_\_\_\_

**Equipment**

Model Number \_\_\_\_\_

Serial Number \_\_\_\_\_

**Engine**

Model \_\_\_\_\_ Type \_\_\_\_\_ Code \_\_\_\_\_

Not for  
Reproduction



SNAPPER is a trademark of  
Briggs & Stratton Power Products Group, LLC  
Milwaukee, WI, USA.



Copyright © 2011, Briggs & Stratton Corporation  
Milwaukee, WI, USA. All Rights Reserved.

# Table of Contents

<b>Operator Safety</b> .....	<b>.4</b>
<b>Features and Controls</b> .....	<b>.9</b>
<b>Operation</b> .....	<b>.10</b>
Before Starting .....	10
Operator Seat Adjustment .....	10
Starting Engine .....	11
Engaging Mower Blade .....	13
Engaging Wheel Drive .....	13
Stopping Engine, Wheel Drive, Blade .....	14
Setting Park Brake .....	15
Cutting Height Adjustment .....	15
Reverse Lockout Mechanism .....	16
<b>Maintenance</b> .....	<b>.17</b>
Maintenance Chart .....	17
General Maintenance .....	18
Storage .....	23
Engine Adjustments and Repairs .....	24
Mower Deck and Component Adjustments .....	24
Rear Engine Rider Drive Components .....	27
Mower Blade Replacement .....	28
Mower Drive Belt Replacement .....	29
Battery .....	30
<b>Troubleshooting</b> .....	<b>.32</b>
<b>Warranty</b> .....	<b>.34</b>
<b>Slope Guide</b> .....	<b>.35</b>

NO FOR  
Reproduction

 <span style="font-weight: bold; font-size: 1.2em;">WARNING</span> 
<p>Battery posts, terminals and related accessories contain lead and lead compounds, chemicals known to the State of California to cause cancer and birth defects or other reproductive harm. Wash hands after handling.</p>

 <span style="font-weight: bold; font-size: 1.2em;">WARNING</span> 
<p>Engine exhaust, some of its constituents, and certain vehicle components contain or emit chemicals known to the State of California to cause cancer or other reproductive harm.</p>

# Operator Safety

---



**WARNING:** This powerful cutting machine is capable of amputating hands and feet and can throw objects that can cause injury and damage! Failure to comply with the following SAFETY instructions could result in serious injury or death to the operator or other persons. The owner of the machine must understand these instructions and must allow only persons who understand these instructions to operate machine. Each person operating the machine must be of sound mind and body and must not be under the influence of any substance, which might impair vision, dexterity or judgment. If you have any questions pertaining to your machine which your dealer cannot answer to your satisfaction, contact Customer Service (1-800-935-2967 or [www.snapper.com](http://www.snapper.com)).

## Protection for Children

Tragic accidents can occur if the operator is not alert to the presence of children. Children are often attracted to the machine and the mowing activity. Children who have been given rides in the past may suddenly appear in the mowing area for another ride and be run over or backed over by the machine. Never assume that children will remain where you last saw them.

1. KEEP children out of the mowing area and under the watchful care of a responsible adult other than the operator.
2. DO NOT allow children in yard when machine is operated (even with the blade OFF).
3. DO NOT allow children or others to ride on machine, attachments or towed equipment (even with the blades OFF). They may fall and be seriously injured.
4. DO NOT allow pre-teenage children to operate machine.
5. ALLOW only responsible adults & teenagers with mature judgment under close adult supervision to operate machine.
6. DO NOT operate blades in reverse. STOP BLADES. LOOK and SEE behind and down for children, pets and hazards before and while backing.
7. USE EXTRA CARE when approaching blind corners, shrubs, trees, or other objects that may obscure vision.

## Protection against Tipovers

Slopes are a major factor related to loss-of-control and tip-over accidents, which can result in severe injury or death. All slopes require extra CAUTION. If you cannot back up the slope or if you feel uneasy on the slope, DO NOT mow it. Use extra care with grass catchers or other attachments; these affect the handling and the stability of the machine. Refer to the Slope Guide at the end of this manual.

1. DO NOT operate machine on slopes exceeding 15 degrees (27% grade).
2. Exercise EXTREME CAUTION on slopes above 10 degrees (18% grade). Turn blades OFF when traveling uphill. Use a slow speed and avoid sudden or sharp turns.
3. DO NOT operate machine back and forth across face of slopes. Operate up and down. Practice on slopes with blades off.
4. AVOID starting, stopping or turning on slopes. If machine stops going uphill or tires lose traction, turn blades OFF and back slowly straight down the slope.
5. STAY ALERT for holes and other hidden hazards. Tall grass can hide obstacles. Keep away from ditches, washouts, culverts, fences and protruding objects.

## Protection against Tipovers

### (Continued From Previous Column)

6. KEEP A SAFE DISTANCE (at least 3 feet) away from edge of ditches and other drop offs. The machine could turn over if an edge caves in.
7. Always begin forward motion slowly and with caution.
8. Use weights or a weighted load carrier in accordance with instructions supplied with a grass catcher. DO NOT operate machine on slopes exceeding 10 degrees (18% grade) when equipped with grass catcher.
9. DO NOT put your foot on the ground to try to stabilize the machine.
10. DO NOT operate machine on wet grass. Reduced traction could cause sliding.
11. Choose a low enough speed setting so that you will not have to stop or shift on a slope. Tires may lose traction on slopes even though the brakes are functioning properly.
12. DO NOT operate machine under any condition where traction, steering or stability is doubtful.
13. Always keep the machine in gear when going down slopes. DO NOT shift to neutral (or actuate hydro roll release) and coast downhill.

## Preparation

1. Read, understand, and follow instructions and warnings in this manual and on the machine, engine and attachments. Know the controls and the proper use of the machine before starting.
2. Only mature, responsible persons shall operate the machine and only after proper instruction.
3. Data indicates that operators age 60 and above, are involved in a large percentage of mower-related injuries. These operators should evaluate their ability to operate the mower safely enough to protect themselves and others from serious injury.
4. Handle fuel with extra care. Fuels are flammable and vapors are explosive. Use only an approved fuel container. DO NOT remove fuel cap or add fuel with engine running. Add fuel outdoors only with engine stopped and cool. Clean spilled fuel from machine. DO NOT smoke.
5. Practice operation of machine with BLADES OFF to learn controls and develop skills.
6. Check the area to be mowed and remove all objects such as toys, wire, rocks, limbs and other objects that could cause injury if thrown by blade or interfere with mowing.

## Protection against Tipovers

### (Continued From Previous Column)

7. Keep people and pets out of mowing area. Immediately STOP blades, STOP engine, and STOP machine if anyone enters the area.
8. Check shields, deflectors, switches, blade controls and other safety devices frequently for proper operation and location.
9. Make sure all safety decals are clearly legible. Replace if damaged.
10. Protect yourself when mowing and wear safety glasses, a dust mask, long pants and substantial footwear.
11. Know how to STOP blades and engine quickly in preparation for emergencies.
12. Use extra care when loading or unloading the machine into a trailer or truck.
13. Check grass catcher components frequently for signs of wear or deterioration and replace as needed to prevent injury from thrown objects going through weak or worn spots.

## Safe Handling of Gasoline

To avoid personal injury or property damage, use extreme care in handling gasoline. Gasoline is extremely flammable and the vapors are explosive.

1. Extinguish all cigarettes, cigars, pipes and other sources of ignition.
2. Use only an approved fuel container.
3. DO NOT remove fuel cap or add fuel with the engine running. Allow the engine to cool before refueling.
4. DO NOT refuel the machine indoors.
5. DO NOT store the machine or fuel container inside where there is an open flame, spark or pilot light such as on a water heater or other appliances.
6. DO NOT fill fuel containers inside a vehicle or on a truck or trailer bed with a plastic liner. Always place the containers on the ground away from the vehicle before filling.
7. Remove gas-powered equipment from the vehicle or trailer and refuel it on the ground. If this is not possible, then refuel equipment using a portable container, rather than a gasoline dispenser nozzle.
8. DO NOT start gas powered equipment in enclosed vehicles or trailers.
9. Keep the nozzle in contact with the rim of the fuel tank or container opening at all times until fueling is complete. DO NOT use a nozzle lock-open device
10. If fuel is spilled on clothing, change clothing immediately.
11. Never overfill a fuel tank. Replace fuel cap and tighten securely.

## Operation

1. Mount and dismount machine from left side. Keep clear of discharge opening at all times.
2. Start engine from operator's seat, if possible. Make sure blades are OFF and parking brake is set.
3. DO NOT leave machine with engine running. STOP engine, STOP blades, SET brake, and Remove key before leaving operators position of any reason.
4. DO NOT operate machine unless properly seated with feet on feet rests or pedal(s).
5. STOP BLADES and ENGINE and make sure blades have stopped before removing grass catcher or unclogging mower to prevent loss of fingers or hand.
6. Blades must be OFF except when cutting grass. Set blades in highest position when mowing over rough ground.
7. Keep hands and feet away from rotating blades underneath deck. DO NOT place foot on ground while BLADES are ON or machine is in motion.
8. DO NOT operate machine without entire grass catcher or guards in place and working. DO NOT point discharge at people, passing cars, windows or doors.
9. Slow down before turning.
10. Watch out for traffic when near or crossing roadways.
11. STOP engine immediately after striking an obstruction. Inspect machine and repair damage before resuming operation.
12. Operate machine only in daylight or with good artificial light.
13. Exercise CAUTION when pulling loads. Limit loads to those you can safely control and attach loads to hitch plate as specified with attachment instructions.
14. On slopes, the weight of the towed equipment may cause loss of traction and loss of control. When towing, travel slowly and allow extra distance to stop.
15. DO NOT operate engine in enclosed areas. Engine exhaust gases contain carbon monoxide, a deadly poison.
16. DO NOT discharge material against a wall or obstruction. Material may ricochet back towards the operator.
17. Only use accessories approved by the manufacturer. See manufacturer's instructions for proper operation and installation of accessories.

# Operator Safety

---

## Towing

1. Tow only with a machine that has a hitch designed for towing. DO NOT attach towed equipment except at the hitch point.
2. Follow the manufacturer's recommendation for weight limits for towed equipment and towing on slopes.
3. DO NOT allow children or others on towed equipment.
4. On slopes, the weight of the towed equipment may cause loss of traction and loss of control.
5. Travel slowly and allow extra distance to stop.

## Maintenance

1. DO NOT store machine or fuel container inside where fumes may reach an open flame, spark or pilot light such as in a water heater, furnace, clothes dryer or other gas appliance. Allow engine to cool before storing machine in an enclosure. Store fuel container out of the reach of children in a well ventilated, unoccupied building.
2. Keep engine free of grass, leaves or excess grease to reduce fire hazard and engine overheating.
3. When draining fuel tank, drain fuel into an approved container outdoors and away from open flame.
4. Check brakes frequently; adjust, repair or replace as needed.
5. Keep all bolts, nuts and screws properly tight. Check that all cotter pins are in proper position.

## Maintenance

### (Continued From Previous Column)

6. Always provide adequate ventilation when running engine. Exhaust gases contain carbon monoxide, an odorless and deadly poison.
7. Disconnect negative (black) cable from battery before performing maintenance or service. Cranking engine could cause injury.
8. DO NOT work under machine without safety blocks.
9. Service engine and make adjustments only when engine is stopped. Remove spark plug wire(s) from spark plug(s) and secure wire(s) away from spark plug(s).
10. DO NOT change engine governor speed settings or overspeed engine.
11. Lubricate machine at intervals specified in manual to prevent controls from binding.
12. Mower blades are sharp and can cut. Wrap the blades or wear heavy leather gloves and use CAUTION when handling them.
13. DO NOT test for spark by grounding spark plug next to spark plug hole; spark plug could ignite gas exiting engine.
14. Have machine serviced by an authorized dealer at least once a year and have the dealer install any new safety devices.
15. Maintain or replace safety and instruction labels as necessary.
16. Use only factory authorized replacement parts or like parts when making repairs.

## Decal Identification

**NOTICE**

Remove battery before standing mower on end for more than **2** hours.

7101109

**Remove Battery - 7101109**

**Before starting engine**

- Press clutch/brake pedal fully down
- Engage parking brake
- Blade lever must be off
- Move shift lever to "N" neutral

**⚠ DANGER**

**Carbon monoxide hazard**

- Only operate machine outdoors.
- Avoid inhaling exhaust fumes.

7101112

**Before Starting - 7101112**

**⚠ DANGER**

**Amputation and thrown objects hazard**

- Keep hands and feet away from deck.
- Do not operate mower unless discharge chute or entire grass catcher is in its proper place.

7101110

**Danger Thrown Objects - 7101110**

**⚠ WARNING**

**Fire Hazard.** Operation of this equipment may create sparks that can start fires around dry vegetation. A spark arrestor may be required. The operator should contact local fire agencies for laws or regulations relating to fire prevention requirements.

7102746

**Spark Arrestor - 7102746**

**⚠ WARNING**

**Avoid serious injury or death**

- Read the operator's manual before using machine
- Keep safety devices (guards, shields, switches, etc.) in place and working.
- Disengage all drives, shut off engine and remove key before leaving operating zone.
- Remove objects that could be thrown by the blade.

**Amputation hazard**

- Do not mow when children or others are around.
- Do not carry riders (especially children) even with the blades off. They may fall off or return for another ride when you are not expecting it.
- Look down and behind before and while backing.

**Fire hazard**

- Keep unit cleaned of debris
- Allow engine to cool for at least 3 minutes before refueling.

**Roll-over hazard**

- Go up and down slope, not across
- If machine stops while going uphill stop the blades and back down slowly
- Avoid sudden turns and slopes over 10°

10 Max

7101111

**Safety Panel - 7101111**



**Height of Cut - 703440**

# Operator Safety

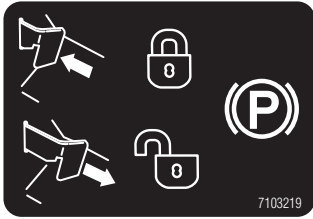

**Parking Brake - 7103219**

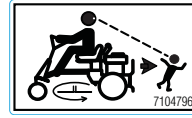

**Reverse Lockout - 7104796**

**IMPORTANT**

- Use only rechargeable valve regulated (sealed) non-spillable batteries in this product. Battery must be factory approved part or equivalent.
- Do not overcharge.

7105102

**Non-Spillable Battery - 7105102**

**CAUTION**

**Fire Hazard**

- Do not overfill tank.
- Empty tank before standing unit on end.

7104797

**Fuel Tank - 7104797**

**WARNING**

**AVOID SERIOUS INJURY OR DEATH**

- Read Operator's Manual before working with battery.
- Always wear goggles when working near battery.
- Keep children, open flames and sparks away from battery.
- Use only constant voltage battery chargers made for valve regulated (sealed) non-spillable batteries. (3.6 amps max.)

7105103

**Battery Warning - 7105103**



**IMPORTANT**

The figures and illustrations in this manual are provided for reference only and may differ from your specific model. Contact your dealer if you have questions.

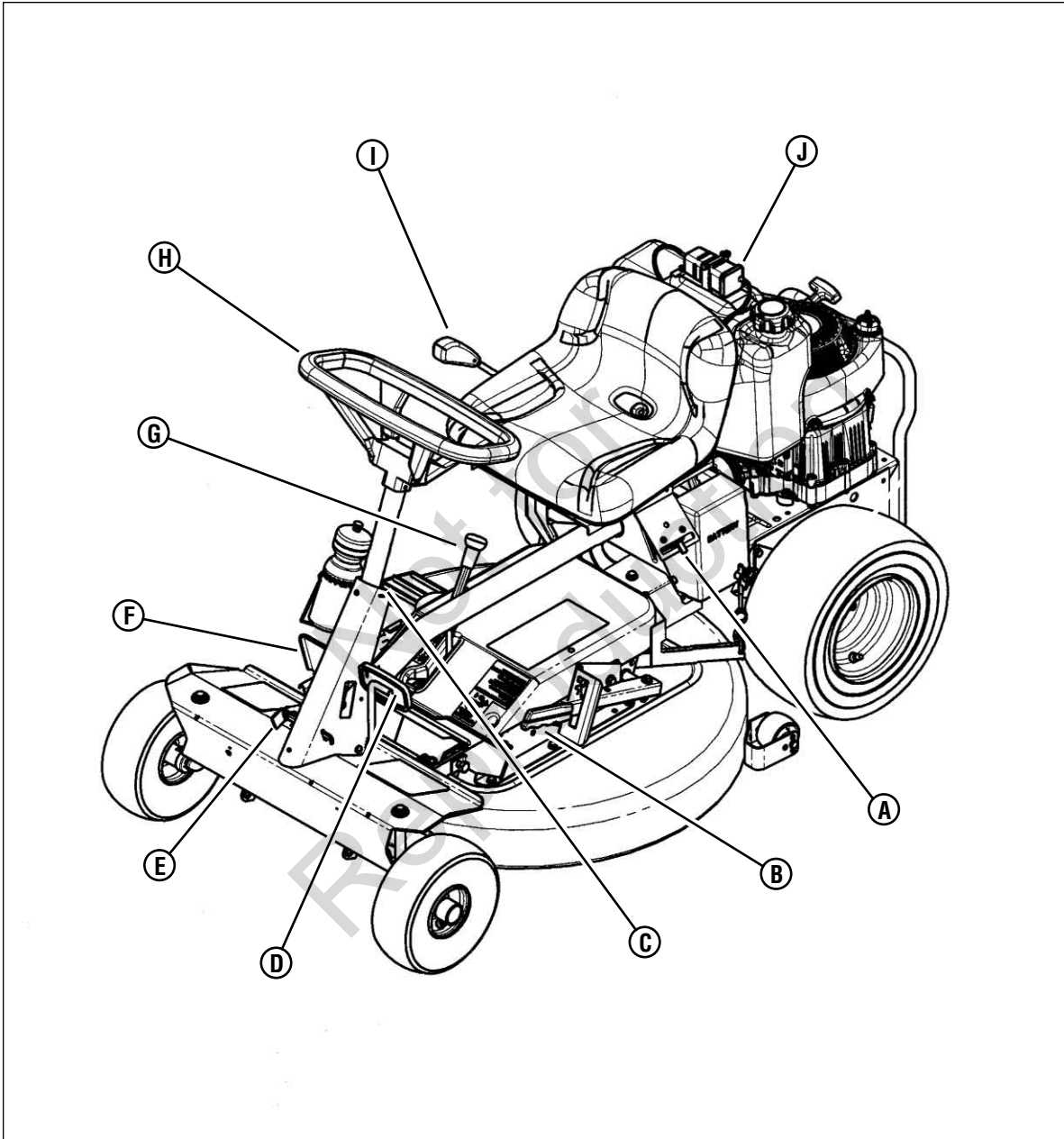

## Features and Controls

- |    |                      |    |                          |
|----|----------------------|----|--------------------------|
| A. | Engine Speed Control | F. | Blade Pedal              |
| B. | Cutting Height Lever | G. | Blade Lever              |
| C. | Ignition Switch      | H. | Steering Wheel           |
| D. | Clutch/Brake Pedal   | I. | Transmission Shift Lever |
| E. | Park Brake Latch     | J. | Fuel Tank                |

# Operation

## Before Starting

Make the following checks and perform the service required before each start-up:

1. Check the tire pressure; add or release air as needed to bring pressure to 15 PSI in front and 12 PSI in rear.
2. Check guards, deflectors and covers to make sure all are in place and securely tightened.
3. Check engine oil and add oil as needed to bring level up to the FULL mark (**A, Figure 1**). Refer to the engine manual for oil specifications.

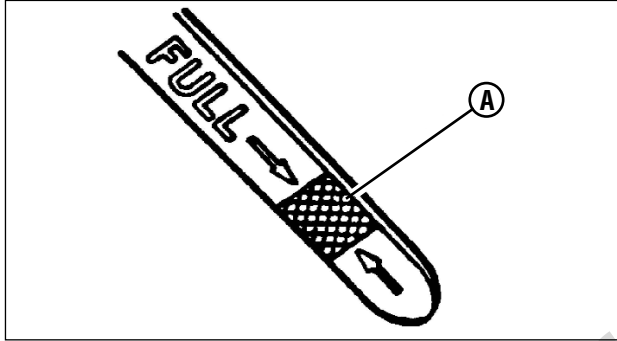

Figure 1: Engine oil 'Full' mark

4. Adjust the seat (**A, Figure 3**) as needed to the most comfortable position. Refer to the Section entitled "OPERATOR'S SEAT ADJUSTMENT".
5. Check the blade control to insure it works freely. If the blade pedals are depressed, the blade lever can be moved manually from "ON" to "OFF" to stop the blade.
6. Check the Reverse Lockout Mechanism. With the blade pedals depressed, the shift lever must not go into reverse.
7. Clean the exterior surfaces of the cutting deck and engine of any accumulation of dirt, grass, oil, etc. Keep the engine air intake screen and cooling fins clear at all times.
8. Add fuel to the fuel tank after pushing the Rear Engine Rider outside where fumes can dissipate. Make sure the fuel filler cap (**A, Figure 2**) is tight after refueling. Refer to the engine manual for fuel specifications.

**IMPORTANT:** Do not overfill. (See statement below.)

### IMPORTANT

To avoid damaging the emissions system:

- Do not overfill the fuel tank. Stop filling the tank when fuel collects in the filler neck.
- Empty the fuel tank before standing the machine on its rear bumper.

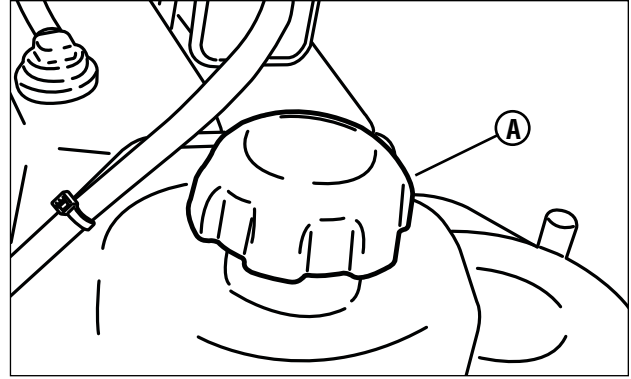

Figure 2: Fuel filler cap

## Operator Seat Adjustment

1. With the engine stopped, loosen the two adjusting knobs (**A, Figure 3**) and move the seat to the desired position. After adjustment, tighten the knobs securely.

*NOTE: If the seat does not move after loosening the knobs, it may be necessary to loosen the 5/16" patch lock screws or hex nuts (**B**) located at the rear of the seat.*

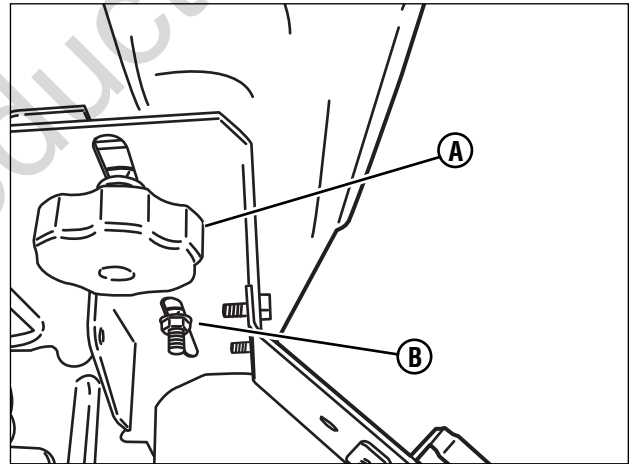

Figure 3: Operator seat adjustment

## Starting and Operation

### Engine (Electric Start)

**IMPORTANT:** When the ignition key is turned to “START”, the engine will turn over, but will not start unless the Clutch/Brake pedal is pressed all the way down, and the Blade Lever is in the “OFF” position. The operator should be in the seat.

Start the engine as follows:

1. Move the transmission shift lever to the (N) Neutral position. Refer to the section entitled “Wheel Drive”.

**IMPORTANT:** DO NOT start the engine with the transmission shift lever in a drive position.

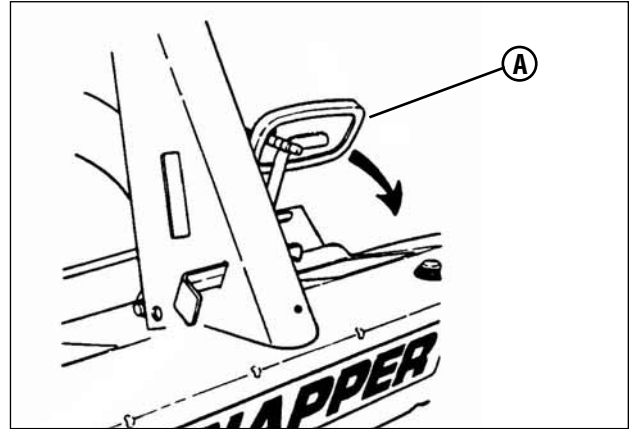

Figure 5: Engaging the clutch/brake pedal

**⚠ WARNING ⚠**

It is possible to start the engine with the transmission shift lever in a drive position. Follow starting instructions carefully.

2. Make certain the Blade Lever (**A, Figure 4**) is in the “OFF” position.

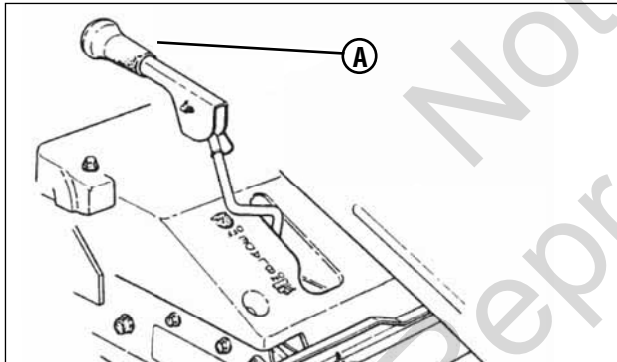

Figure 4: Blade lever (in ‘Off’ position)

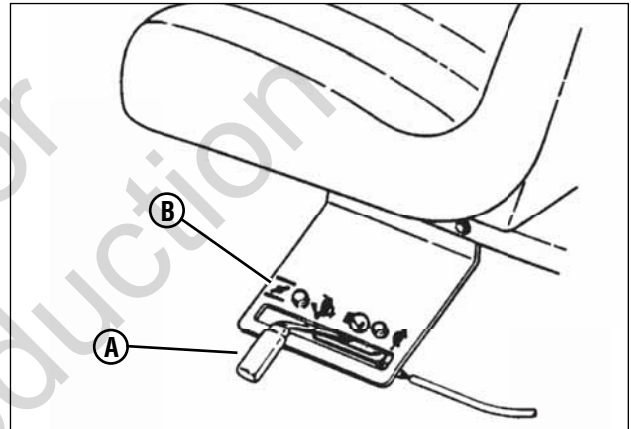

Figure 6: Engine speed control

3. Press the Clutch/Brake Pedal (**A, Figure 5**) all the way down and hold while starting the engine.
4. Move the engine speed control (**A, Figure 6**) to the choke position (**B**) to start a cold engine.
5. Turn the ignition key (**A, Figure 7**) to the “START” position until the engine starts.

**NOTE:** If after 5 seconds of cranking the engine does not start, release the key, make sure the Clutch/Brake Pedal is fully depressed, and attempt starting again after waiting for approximately 20 seconds.

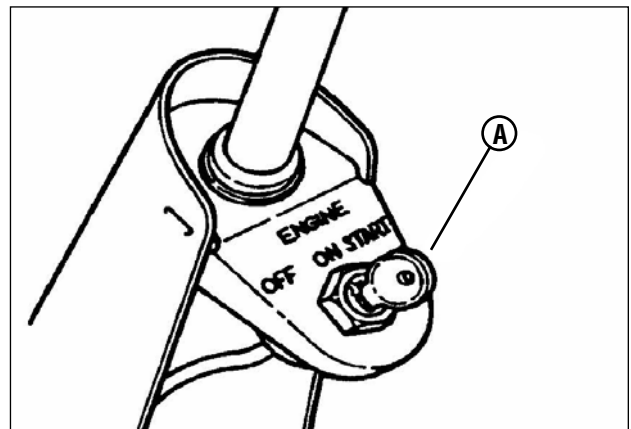

Figure 7: Ignition key

6. After the engine starts, move the engine speed control to the “FAST” position and allow a brief warm-up until engine runs smooth.

(Continued on Next Page)

# Operation

## Starting and Operation (Continued)

### Engine (Electric Start) (Continued)

- Should the battery be too weak to start the engine, refer to the Section entitled "Engine (Manual Start)" to manually start the electric start engines.
- On Model 3317524BVE, the engine is equipped with a fuel shut-off solenoid. If the battery is dead, the engine can be started with the recoil back-up starter if the engine speed control is in the choke position (HOT engine or COLD engine).

### Engine (Manual Start)

**IMPORTANT:** When the key is turned to "ON", and the recoil handle is pulled, the engine will turn over, but will not start unless the Clutch/Brake Pedal is pressed all the way down with the Park Brake engaged, and the Blade Lever is in the "Off" position.

Start the engine as follows:

- Move the transmission shift lever to the (N) Neutral position. Refer to the section entitled "Wheel Drive".

**IMPORTANT:** DO NOT start the engine with the transmission shift lever in a drive position.



### WARNING



It is possible to start the engine with the transmission shift lever in a drive position. Follow starting instructions carefully.

- Make certain the Blade Lever (A, Figure 4) is in the "OFF" position.
- Press the Clutch/Brake Pedal (A, Figure 8) all the way down, move the park brake latch (B) over, and release the clutch/brake pedal to set the park brake.

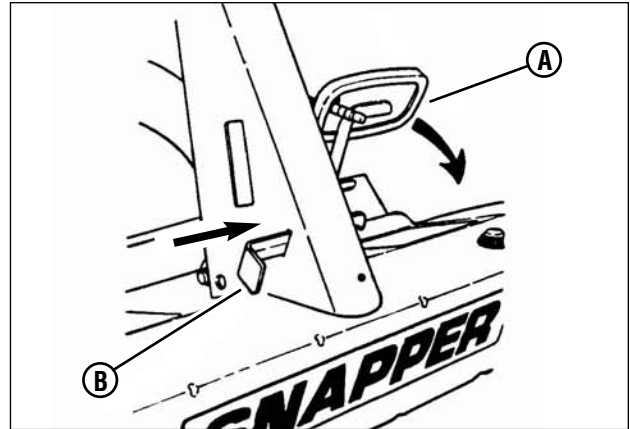

Figure 8: Setting the park brake

- Move the engine speed control (A, Figure 6) to the choke position (B) to start a cold engine.
- Turn the key (A, Figure 9) to the "ON" position.

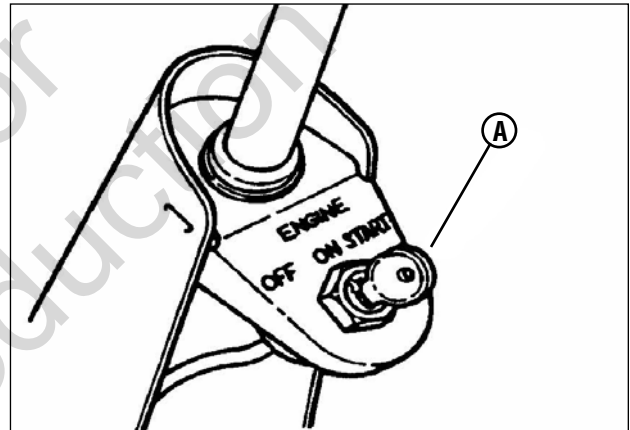

Figure 9: Key

- Pull the starter rope, located on the engine recoil, with a smooth, even motion until the engine starts.

**NOTE:** Always guide the starter rope back into the recoil housing. Never allow rope to snap back.

After the engine starts, move the engine speed control to the "FAST" position.

- Allow a brief warm-up until the engine runs smooth.

**WARNING**

Once blade is disengaged, it should come to a complete stop in 3 seconds or less. If the blade continues to rotate after 3 seconds, the blade brake must be adjusted. Refer to Section “BLADE BRAKE ADJUSTMENT” for adjustment procedures or return machine to an authorized dealer for adjustment. **DO NOT CONTINUE** to operate machine until blade brake is adjusted and functioning properly.

**WARNING**

**DO NOT** operate blades in reverse. **STOP BLADES**. **LOOK** and **SEE** behind and down for children, pets and hazards before and while backing.

## Starting and Operation (Continued)

### Mower Blade

1. With the engine running, move the engine speed control to the “FAST” position.
2. Move the blade lever (**A, Figure 10**) forward to the “ON” position, then depress the blade pedals (**B**) to hold the blade lever in the “ON” position.

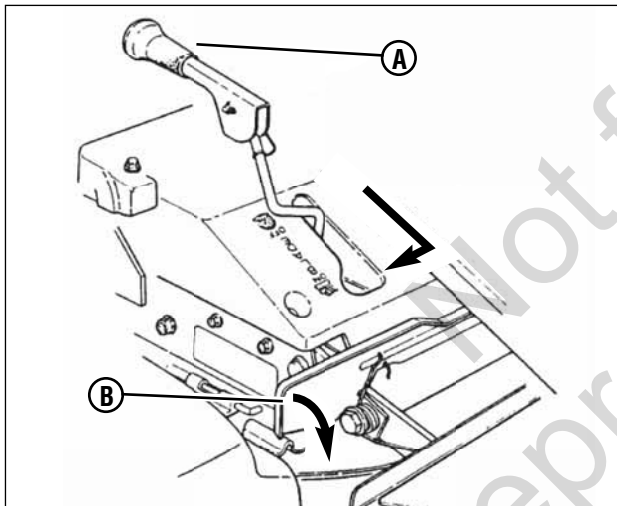

Figure 10: Engaging the mower blade

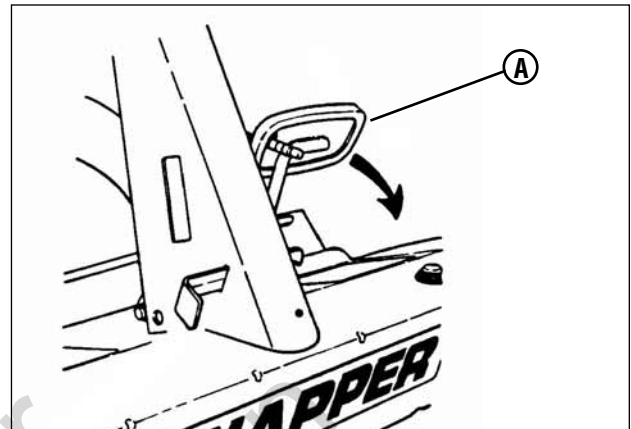

Figure 11: Engaging the clutch/brake pedal

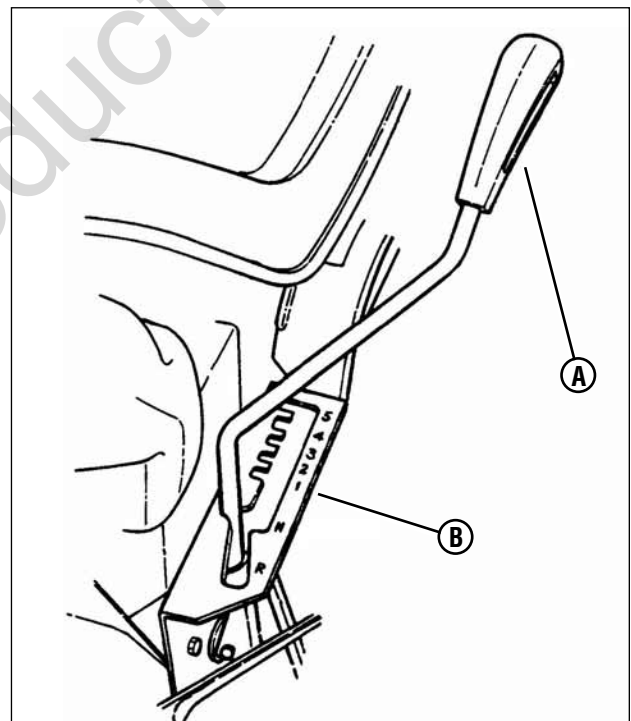

Figure 12: Transmission shift lever

### Wheel Drive

1. With the engine running, adjust the engine speed control to the “FAST” position.
2. Depress the clutch/brake pedal (**A, Figure 11**).
3. Place the transmission shift lever (**A, Figure 12**) into the first forward speed notch (**B**).
4. Release the clutch/brake pedal to begin forward motion.
5. During forward motion, the transmission shift lever may be placed in any desired forward speed without depressing the clutch/brake pedal.

**NOTE:** For best cutting results, move the transmission shift lever into a slow forward speed and the engine speed control to a fast position. This combination will allow the mower blades to lift the grass while cutting smoothly and evenly.

# Operation

**WARNING**

DO NOT leave the machine with the engine running. STOP Blade. STOP engine. Shift to neutral and engage park brake. Remove key.

## Stopping - Engine, Wheel Drive, Blade

### Engine

1. Stop the engine by turning the key (A, Figure 13) to the "OFF" position.

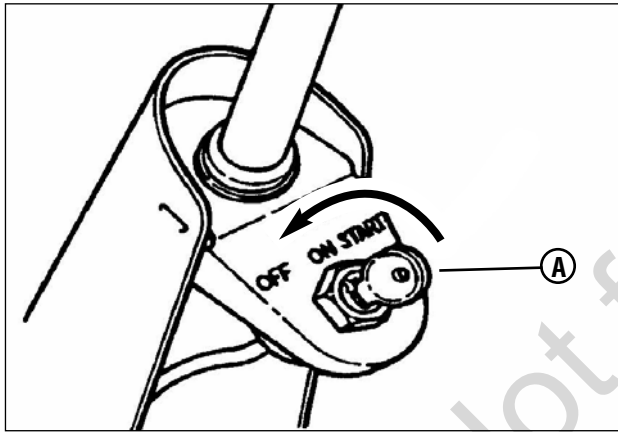

Figure 13: Turning key to 'Off'

### Wheel Drive

1. Stop motion of the Rear Engine Rider by pushing the clutch/brake pedal (A, Figure 14) all the way down to apply the brake.

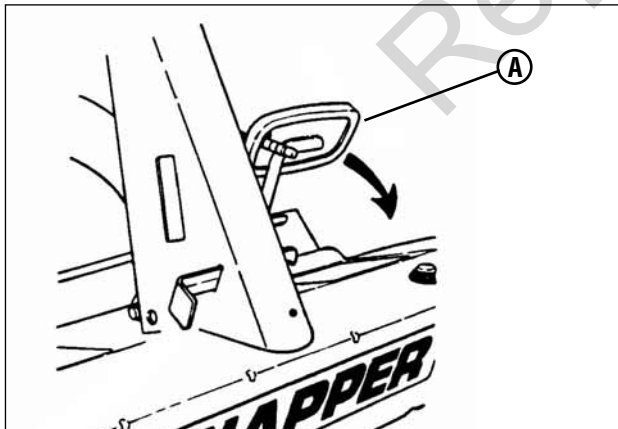

Figure 14: Engaging the clutch/brake pedal

### Mower Blade

1. Stop the mower blade by releasing the blade pedals (A, Figure 15) or moving the blade lever (B) rearward to the "OFF" position.

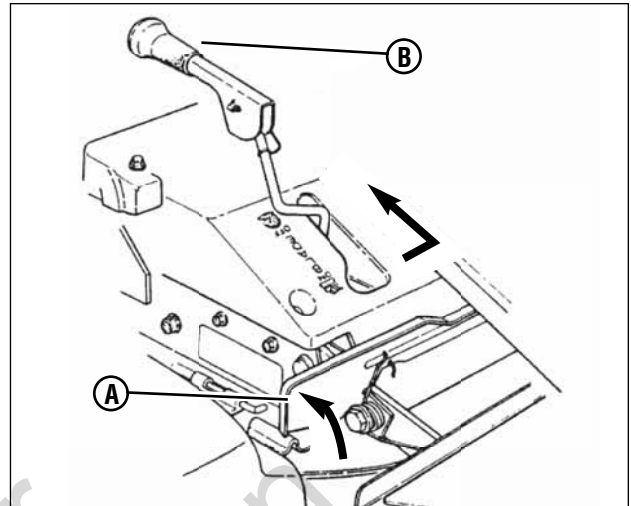

Figure 15: Stopping the mower blade

**WARNING**

Once blade is disengaged, it should come to a complete stop in 3 seconds or less. If the blade continues to rotate after 3 seconds, the blade brake must be adjusted. Refer to Section "BLADE BRAKE ADJUSTMENT" for adjustment procedures or return machine to an authorized dealer for adjustment. DO NOT CONTINUE to operate machine until blade brake is adjusted and functioning properly.

## Stopping - Engine, Wheel Drive, Blade (Continued)

### Park Brake

1. To set the park brake, press the clutch/brake pedal (A, Figure 16) all the way down, slide the park brake latch (B) all the way in to the engaged position, and release the clutch/brake pedal. A detent in the park brake latch will keep the park brake engaged.

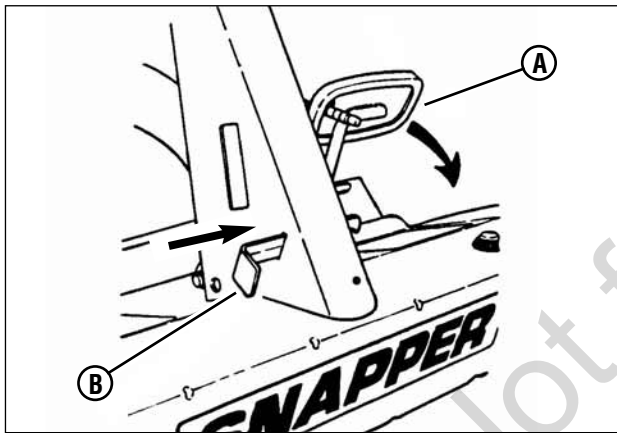

Figure 16: Setting the park brake

2. Release the park brake by pressing down firmly on the clutch/brake pedal (A, Figure 17). The park brake latch (B) is spring-loaded, and will slide back to the disengaged position unassisted.

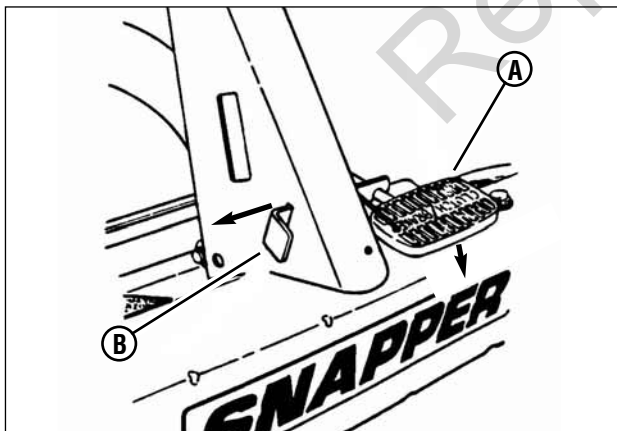

Figure 17: Releasing the park brake

### Cutting Height Adjustment

1. Adjust the cutting height by raising or lowering the deck lift lever (A, Figure 18) into the desired height of cut notch (B).

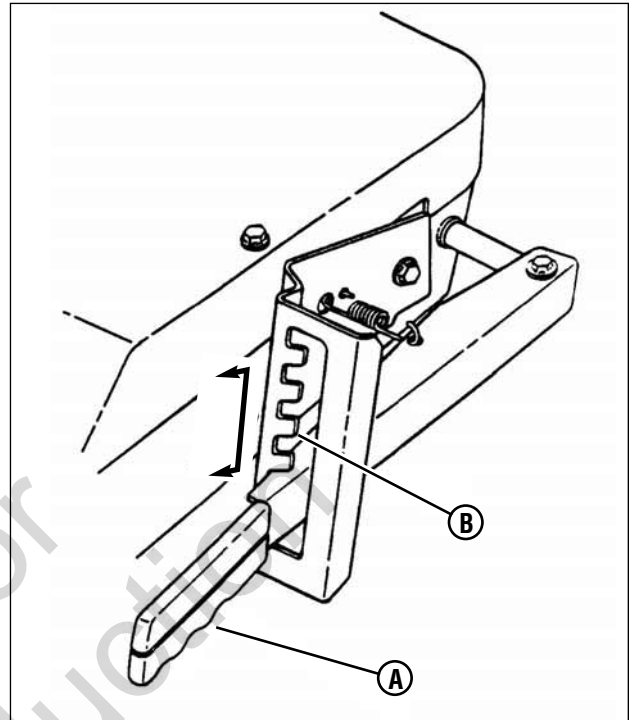

Figure 18: Cutting height adjustment



# Operation

## Reverse Lockout Mechanism

Data indicates that tragic back-over accidents occur each year. These accidents usually involve unsupervised children. Many times these children have been given rides on the machine and have been trained to view this potentially dangerous piece of machinery as fun rather than being taught how to avoid danger.

This riding mower has a Reverse Lockout Mechanism. This mechanism prevents the mower from being shifted into reverse with the blade running. To shift into reverse you must first stop the blade by releasing the blade pedals and then shift to reverse. It is our recommendation that this mechanism remain functional and the operator of this equipment develop the habit of never backing up with the blade running. As the Safety Instructions Indicate, **DO NOT operate blades in reverse. STOP BLADES, LOOK AND SEE BEHIND AND DOWN for children, pets and hazards before and while backing.**

We realize that this could cause a change to your previous mowing method but we encourage you to adjust to this new system. Do not defeat the Reverse Lockout Mechanism.

If you operate your mower near roadways or use attachments that require quicker shifting to reverse, there is an override lever provided. This lever can be pushed and held before starting the blade and will allow reverse operation until the blade pedals are released, at which time the system will return to its Reverse Lockout mode. This feature should never be selected unless you are absolutely sure that no children or others are present in the mowing area and that all children are away and supervised by a responsible adult.

## Reverse Lockout Mechanism Override

1. Stop the machine. Stop the blade.
2. Depress and hold the Override Lever.
3. Depress and hold the Blade Pedals. Release the Override Lever.
4. Move the blade lever forward to "ON" position.



### WARNING



LOOK and SEE behind and down for children, pets and hazards before and while backing.

**IMPORTANT:** DO NOT use the Reverse Lockout Mechanism Override as the normal operating mode. To return to the Reverse Lockout Mechanism mode, release blade pedals to turn blade off. The Override will reset to Reverse Lockout. Check the Reverse Lockout Mechanism frequently for proper function. With the blade pedals depressed, the shift lever must not go into reverse. DO NOT operate machine if Reverse Lockout Mechanism is not functioning properly. Contact your local Snapper dealer for assistance.



### DANGER



LOOK and SEE behind and down for children, pets and hazards before and while backing.  
BLADES must be turned off before backing machine.  
DO NOT allow children on machine (even with blades off) or in yard when mowing.



### Amputation hazard

- Do not mow when children or others are around.
- Do not carry riders (especially children) even with the blades off. They may fall off or return for another ride when you are not expecting it.
- Look down and behind before and while backing.





## Maintenance Chart

<b>TRACTOR AND MOWER</b>
<b>Every 8 Hours or Daily</b>
Check safety interlock system
Clean debris off tractor and mower deck
Clean debris from engine compartment
<b>Every 25 Hours or Annually *</b>
Check tire pressure
Check mower blade stopping time
Check tractor/mower for loose hardware
<b>Every 50 Hours or Annually *</b>
Clean battery and cables
Check tractor brakes
<b>See Dealer Annually to</b>
Lubricate tractor and mower
Check/replace mower blades **

\* Whichever comes first

\*\* Check blades more often in regions with sandy soils or high dust conditions.

<b>ENGINE</b>
<b>First 5 Hours</b>
Change engine oil
<b>Every 8 Hours or Daily</b>
Check engine oil level
<b>Every 25 Hours or Annually *</b>
Clean engine air filter and pre-cleaner **
<b>Every 50 Hours or Annually *</b>
Change engine oil
Replace oil filter
<b>Annually</b>
Replace Air Filter
Replace pre-cleaner
<b>See Dealer Annually to</b>
Inspect muffler and spark arrester
Replace spark plug
Replace fuel filter
Clean engine air cooling system

\* Whichever comes first

\*\* Clean more often in dusty conditions or when air-borne debris is present.

# Maintenance



## WARNING



DO NOT attempt any adjustments, maintenance, service or repairs with the engine running. STOP engine. STOP blade. Engage parking brake. Remove key. Remove spark plug wire from spark plug and secure away from plug. Engine and components are HOT. Avoid serious burns, allow all parts to cool before working on machine. Fuel Filler Cap must be closed securely to prevent fuel spillage.

## Introduction

Contact a local dealer for parts and service assistance. For the correct part or information for a particular Rear Engine Riding Mower, always mention the model and serial number. We recommend returning the Rear Engine Rider to an authorized dealer annually for inspection and addition of any new devices, which might upgrade the safety of the Rear Engine Rider.

## Change Engine Oil

1. Place bricks or wooden blocks under the front wheels to lower the rear of the engine.
2. Loosen or remove the oil fill cap on the engine.
3. Place a 2 quart minimum capacity container under the end of the oil drain (Figure 19).
4. Remove or open the oil drain plug (A or B, Figure 19), depending upon the type of oil drain plug the engine is equipped with.

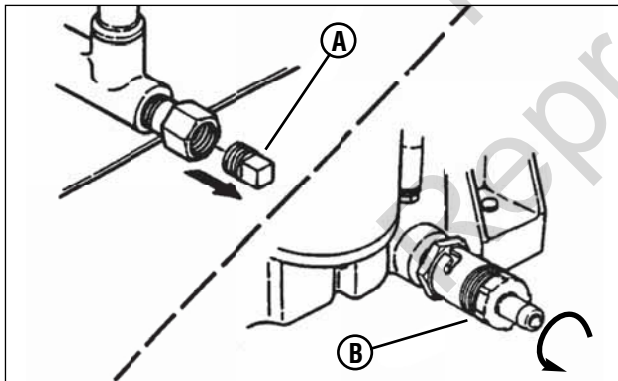

Figure 19: Oil drain plugs

5. After all the oil has drained, replace or close the drain plug, and wipe up any oil that may have spilled. Dispose of used oil properly.
6. Fill the engine crankcase with new oil. Refer to the engine manual for oil specifications.
7. Change the oil filter on engines equipped with oil filters at every oil change. Refer to the engine manual for service instructions.

## Service Engine Air Cleaner

The engine is equipped with a dual element air cleaner. Both the foam pre-cleaner and cartridge require service. Refer to the Engine Manual for recommended service procedures.

## Check Mower Blade

1. Follow the WARNING statement found on this page.
2. Carefully stand the Rear Engine Rider on the rear bumper. (See statement below.)
3. Check the torque of the blade mounting bolts (A, Figure 20). As necessary, torque to 30 to 40 ft. lbs.
4. Check the blade for sharpness, wear and damage. Refer to the section entitled "BLADE WEAR LIMITS".
5. Check the blade for straightness. Refer to the section entitled "ADJUSTING MOWER BLADE".



## DANGER



DO NOT use a cutting blade that shows signs of excessive wear or damage on the Rear Engine Rider. Refer to the section entitled "MOWER BLADE REPLACEMENT" for proper blade inspection and service procedures.

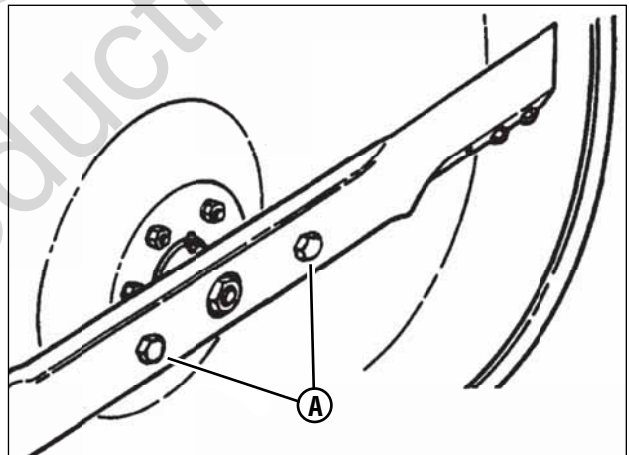

Figure 20: Checking blade bolt torque

## IMPORTANT

To avoid damaging the emissions system:

- Do not overfill the fuel tank. Stop filling the tank when fuel collects in the filler neck.
- Empty the fuel tank before standing the machine on its rear bumper.



## WARNING



DO NOT attempt any adjustments, maintenance, service or repairs with the engine running. STOP engine. STOP blade. Engage parking brake. Remove key. Remove spark plug wire from spark plug and secure away from plug. Engine and components are HOT. Avoid serious burns, allow all parts to cool before working on machine. Fuel Filler Cap must be closed securely to prevent fuel spillage.

### Check the Blade Drive Belt

The blade drive consists of a single belt from the engine to the deck. Inspect for signs of deterioration and proper tension.

1. Lower the deck to the lowest setting.
2. Remove the four self-tapping screws (A, Figure 21), two on each side of mower drive belt cover (B).
3. Slide the cover back and rotate out on the left side of the mower deck.

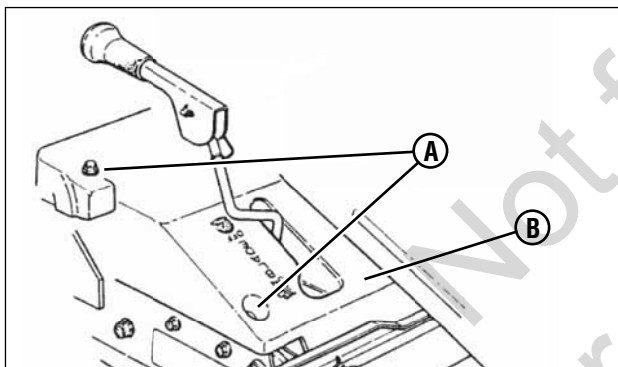

Figure 21: Removing the drive belt cover

4. Raise the deck to the 3rd height of cut position (middle notch). With the engine "OFF", move the blade lever back to the "ON" position and depress the blade pedals.
5. 28" and 30" Decks \*: Measure the belt spacing at the idler pulley (A, Figure 22). The belt spacing (B) should be 1-1/4" but no less than 1". If the measurement is less than 1", the belt tension should be adjusted. Refer to the section entitled "BLADE DRIVE BELT ADJUSTMENT".

\* **IMPORTANT:** The blade drive belt on 33" decks does not require tension adjustment. If the belt becomes worn or slack it must be replaced. Refer to the section entitled "BLADE DRIVE BELT REPLACEMENT".

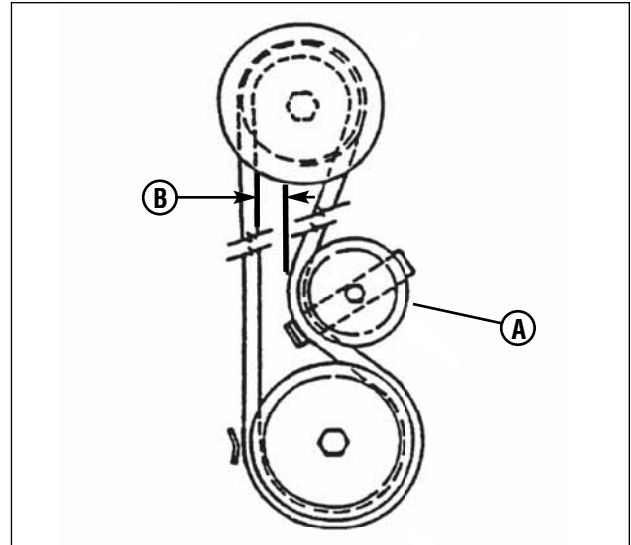

Figure 22: Measuring the belt spacing



## WARNING



The following procedure requires the engine and blades to be operated. Exercise extreme caution. Clear area of loose parts & tools first. Only operate blades when seated in the operator's seat.

### Blade Brake

1. Check the blade brake for proper function. The blade should stop rotating in 3 seconds or less after moving the blade control lever to the "OFF" position or after releasing the blade pedals.



## WARNING



Blades must stop rotating in 3 seconds or less after the blade has been turned off. DO NOT operate machine until blade brake has been adjusted and functioning properly.

2. If the blade continues to rotate longer than 3 seconds do not operate the machine. Refer to the section entitled "BLADE BRAKE ADJUSTMENT", or contact your SNAPPER dealer for assistance.

### Service Brake / Park Brake

1. Check the machine brake for proper function:
  - Engage the park brake, and push the machine. The rear tires should skid.
  - Drive the machine forward and apply the brake. The machine should come to a complete stop in less than 5 ft.
2. If the brakes are not functioning properly, brake adjustment must be completed before operating the machine. Refer to the section entitled "SERVICE BRAKE – PARK BRAKE ADJUSTMENT".

# Maintenance

## Safety Interlock System Checks

**WARNING**

DO NOT operate machine if any safety interlock or safety device is not in place and functioning properly. DO NOT attempt to defeat, modify or remove any safety device.

Engine must not start if:

1. The Clutch/Brake Pedal is not fully depressed OR,
2. The Blade Control is in the "ON" (blades engaged) position.

Engine should start if:

1. The Blade Control is in the "OFF" (blades disengaged) position AND,
2. The Clutch/Brake Pedal is fully depressed.

Engine and blades must stop if:

1. The operator rises off of seat with Blade Control in "ON" (blades engaged) position OR,
2. The operator rises off of seat with Clutch/Brake Pedal not fully depressed.

## Reverse Lockout Mechanism

Check the function of the Reverse Lockout Mechanism with the engine off.

1. Depress and hold the blade pedals.
2. Depress and hold the clutch/brake pedal.
3. With Steps 1 and 2 performed, the shift lever must not go into reverse.

**WARNING**

DO NOT operate machine if Reverse Lockout Mechanism is not functioning properly. Contact your SNAPPER dealer immediately for assistance.

## Lubrication – Grease Fittings

The following components on the Rear Engine Rider are equipped with grease fittings and require periodic lubrication. Apply General Purpose grease (NLGI No.2) with a grease gun.

1. Front Wheel Bearings. Refer to the section entitled "FRONT WHEEL BEARINGS – LUBRICATION".
2. Rear Axle Bearing. Refer to the section entitled "REAR AXLE BEARING – LUBRICATION".
3. Mower Blade Spindle. Refer to the section entitled "MOWER BLADE SPINDLE – LUBRICATION".
4. Shift Lever. Refer to the section entitled "SHIFT LEVER – LUBRICATION".

## Check Engine

1. Change the engine oil. Refer to the section entitled "CHANGE ENGINE OIL". Refer to the engine manual for oil specifications.
2. Change the air filter:
  - Pull up and rotate the air cleaner latch (A, Figure 23) to remove the air cleaner cover (B).

**IMPORTANT:** When the cover is removed, you are viewing the carburetor side of the air filter, which will appear clean. Remove the filter and pre-cleaner for inspection.

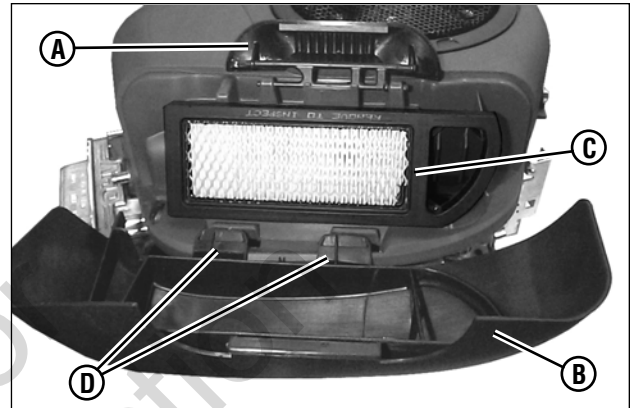

Figure 23: Opening the engine air cleaner cover  
(May vary by model - refer to engine manual)

- Remove the air cleaner (C).
- Remove and clean the engine air pre-cleaner (located behind the air cleaner). Refer to the engine manual for cleaning and service instructions.
- Install the pre-cleaner and replace the air cleaner per the engine manual.
- Reinstall the air cleaner cover. Engage the latch over the cover and rotate and push down to lock.

**IMPORTANT:** The tabs (D) on the air cleaner cover must be completely inserted into the corresponding slots in the engine cover, or the compartment will not be completely sealed to prevent debris from entering into the carburetor.



## WARNING



DO NOT attempt any adjustments, maintenance, service or repairs with the engine running. STOP engine. STOP blade. Engage parking brake. Remove key. Remove spark plug wire from spark plug and secure away from plug. Engine and components are HOT. Avoid serious burns, allow all parts to cool before working on machine. Fuel Filler Cap must be closed securely to prevent fuel spillage.

### Mower Deck Levelness

Check the mower deck for proper level. Adjust as required. Refer to the section entitled "MOWER DECK ADJUSTMENT – LEVELNESS".

### Clean Mower Deck

1. Follow the WARNING statement found on this page.
2. Carefully stand the Rear Engine Rider on the rear bumper. (See statement below.)
4. Clean the underside of the mower deck, removing all accumulation of grass clippings and debris.
5. Clean the top of the deck, removing all grass clippings and debris.

### Mower Blade Spindle - Lubrication

1. Follow the WARNING statement found on this page.
2. Carefully stand the Rear Engine Rider on the rear bumper. (See statement below.)
3. Lubricate the spindle grease fitting (A, Figure 24) with three shots of general purpose grease from a grease gun.

**IMPORTANT:** If the unit will be on its rear bumper for longer than two hours, remove the battery. Refer to the Section entitled "BATTERY REMOVAL".

## IMPORTANT

### To avoid damaging the emissions system:

- Do not overfill the fuel tank. Stop filling the tank when fuel collects in the filler neck.
- Empty the fuel tank before standing the machine on its rear bumper.

### Mower Deck Linkage - Lubrication

Lubricate all mower deck linkage pivot points with a light coat of motor oil.

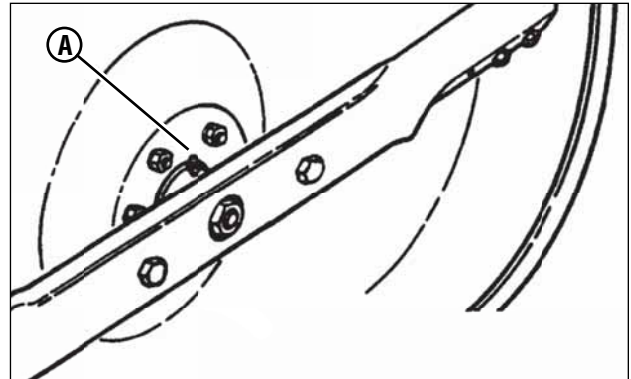

Figure 24: Mower blade spindle grease fitting

### Front Wheel Bearing - Lubrication

Lubricate the front wheel grease fittings (A, Figure 25) with five shots of general purpose grease, from a grease gun.

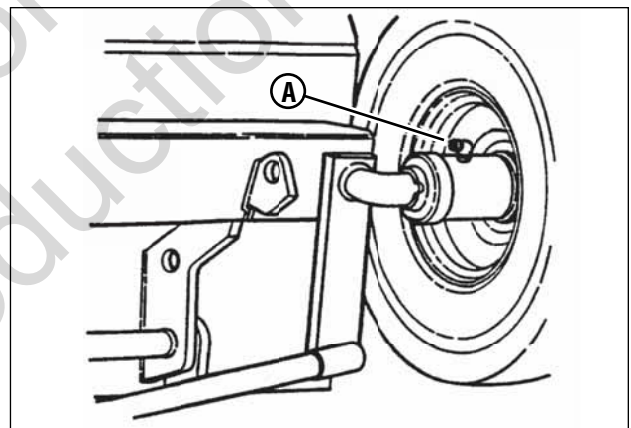

Figure 25: Front wheel grease fitting

### Shift Lever - Lubrication

Lubricate the shift lever grease fitting (A, Figure 26) with two shots of general purpose grease from a grease gun.

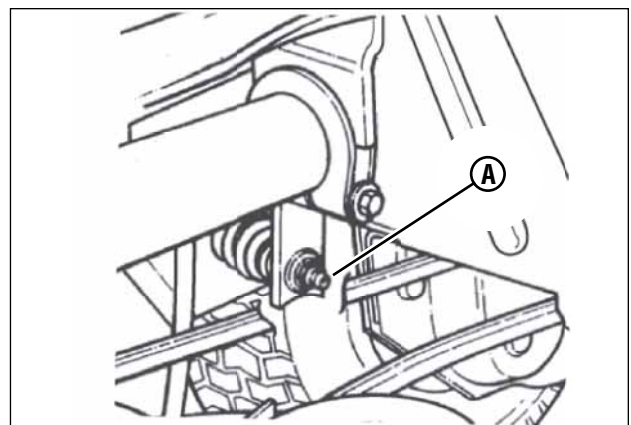

Figure 26: Shift lever grease fitting



# Maintenance



## WARNING



DO NOT attempt any adjustments, maintenance, service or repairs with the engine running. STOP engine. STOP blade. Engage parking brake. Remove key. Remove spark plug wire from spark plug and secure away from plug. Engine and components are HOT. Avoid serious burns, allow all parts to cool before working on machine. Fuel Filler Cap must be closed securely to prevent fuel spillage.

### Rear Axle Bearing - Lubrication

1. The grease fitting (A, Figure 27) on the left rear axle bearing requires three shots of general purpose grease from grease gun.
2. The right rear axle bearing is lubricated by the differential lubricant and requires no grease.

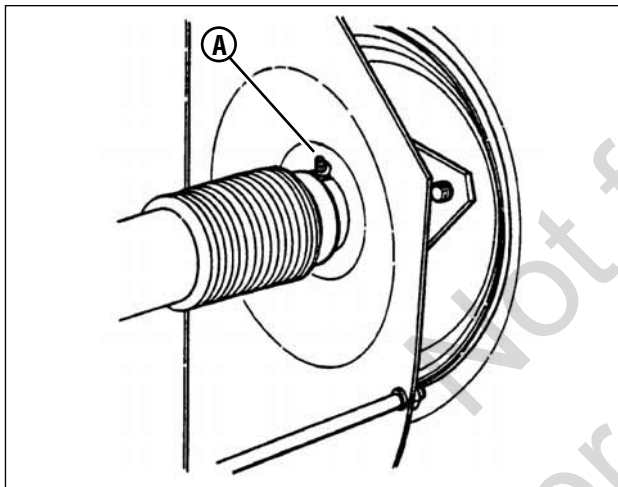

Figure 27: Rear axle grease fitting

### Differential / Chain Case - Lubrication

1. Stand the rear engine rider on its rear bumper and check the fill/level plug (A, Figure 28) on the differential (B) for cracks and wear. Replace the fill/level plug if signs of wear are visible.

**IMPORTANT:** If the unit will be on its rear bumper for longer than two hours, remove the battery. Refer to the Section entitled "BATTERY REMOVAL".

2. To check lubricant, remove the fill/level plug and visually inspect for lubricant on the internal parts of the differential. If no lubricant is visible on the internal parts of the differential, add transmission grease as needed.

**IMPORTANT:** Overfilling of the differential with lubricant will cause lubricant to leak onto drive components of the Rear Engine Rider.

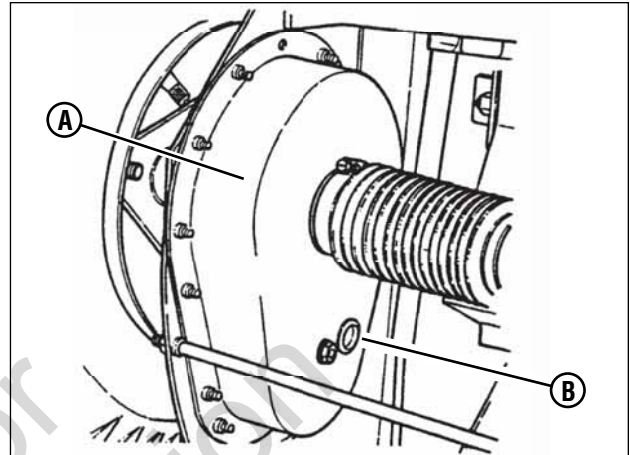

Figure 28: Differential lubricant check

3. Check the fill/level plug (A, Figure 29) on the chain case (B) for damage. If signs of wear or cracks are visible, replace with a new plug.
4. To check lubricant in the chain case, remove the fill/level plug and look for lubricant on the internal components of the chain case. If no lubricant is visible, add transmission grease as needed.

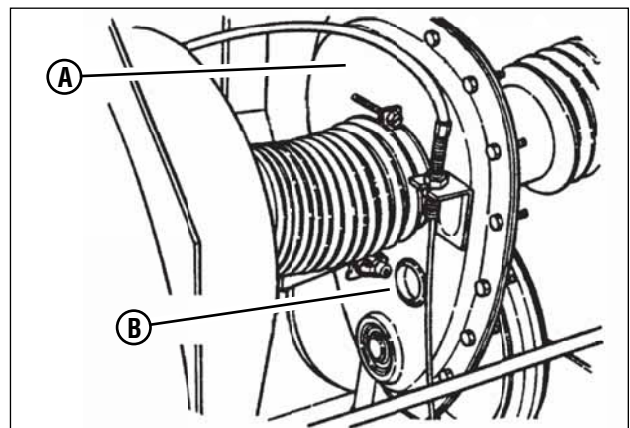

Figure 29: Chain case lubricant check

### Engine Service

Check the maintenance section of the Engine Manual for additional engine service.



## WARNING



DO NOT attempt any adjustments, maintenance, service or repairs with the engine running. STOP engine. STOP blade. Engage parking brake. Remove key. Remove spark plug wire from spark plug and secure away from plug. Engine and components are HOT. Avoid serious burns, allow all parts to cool before working on machine. Fuel Filler Cap must be closed securely to prevent fuel spillage.

### Engine

Perform all maintenance as specified in the Maintenance Chart in this manual.

### Fuel Filter

**IMPORTANT:** Service the fuel filter on a COLD ENGINE ONLY!

1. Drain the fuel from the fuel tank.
2. Start the engine and allow it to run until the engine runs out of fuel.
3. Remove the hose clamps (**B, Figure 30**) from the fuel filter (**A**).
4. Remove the fuel lines from the filter. Discard the filter.
5. Install a new fuel filter.
6. Carefully reinstall the fuel clamps.
7. Check the fuel system for leaks.

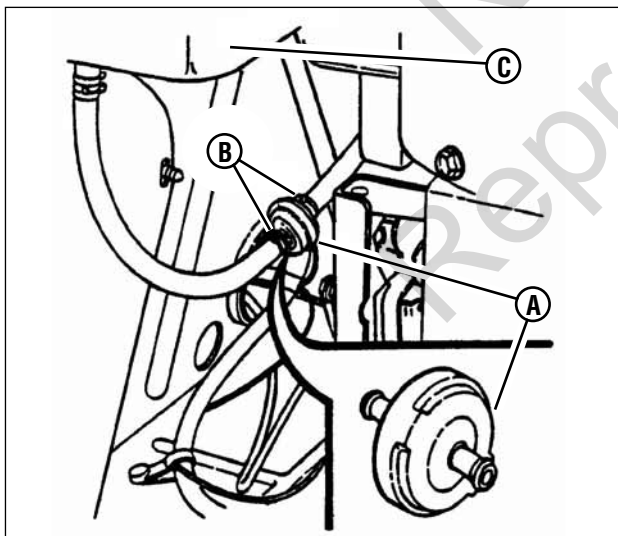

Figure 30: Replacing the fuel filter

In addition to regular maintenance, the following components of the Rear Engine Rider should be carefully inspected regularly for wear or damage.

1. All bushings and pivot areas.
2. Check both front wheel king pins.
3. Transmission shift lever and detent.
4. Clutch disc.
5. Clutch yoke.
6. Mower deck linkage and pivot areas.

Replace worn or damaged parts. Use only factory authorized replacement parts or like parts when making repairs.

### Storage (Out of Season)

If desired, the Rear Engine Rider can be stored on the rear bumper. Perform the following procedures to insure the Rear Engine Rider will operate properly when taken out of storage.

1. Thoroughly clean the Rear Engine Rider by removing all grass clippings and debris.
2. Perform maintenance and lubrication as required.
3. Drain the fuel from the fuel tank.
4. Start the engine and allow it to run until the engine runs out of fuel. This allows the carburetor and fuel system to remain clean during storage.
5. Remove and store the battery. Refer to the Section entitled "BATTERY STORAGE".
6. Carefully stand the Rear Engine Rider on its rear bumper in the desired location for storage.

### IMPORTANT

**To avoid damaging the emissions system:**

- Do not overfill the fuel tank. Stop filling the tank when fuel collects in the filler neck.
- Empty the fuel tank before standing the machine on its rear bumper.

# Maintenance



## WARNING



DO NOT attempt any adjustments, maintenance, service or repairs with the engine running. STOP engine. STOP blade. Engage parking brake. Remove key. Remove spark plug wire from spark plug and secure away from plug. Engine and components are HOT. Avoid serious burns, allow all parts to cool before working on machine. Fuel Filler Cap must be closed securely to prevent fuel spillage.

## Engine Adjustments and Repair

Refer to the engine manual for those adjustments and/or repairs that can be made by the owner.

## Mower Deck and Component Adjustments

The following mower deck and component adjustments and repairs can be made by the owner. However, if there is difficulty in achieving these adjustments and repairs, it is recommended that these repairs be made by an authorized dealer.

### Blade Brake Adjustment

The automatic Blade Brake should stop the blades within 3 seconds any time the blades are disengaged by moving the blade lever to the "OFF" position or by releasing the Blade Pedals. If the blades take longer than 3 seconds to stop, perform the following measurement and adjustment.

1. With the blade engagement lever disengaged, measure the distance between the front of the blade lever (**A**, **Figure 31**) and the edge of the latch plate (**B**). The dimension (**C**) should be 3" to 3-1/4" clearance between the lever and the edge of the plate. If the dimension is incorrect go to step 2.
2. Remove the belt cover. Refer to the section entitled "BLADE BELT COVER REMOVAL".
3. If the dimension is greater than 3-1/4", rotate the brake adjustment nut (**A**, **Figure 32**) clockwise to increase brake tension. If the dimension is less than 3", rotate the nut counter-clockwise to decrease brake tension.
4. Reinstall the belt cover and tighten the bolts securely.



## WARNING



Once blade is disengaged it should come to a stop in 3 seconds or less. If the blade continues to rotate after 3 seconds the blade brake must be adjusted. DO NOT continue to operate the machine if the blade brake is not operating properly.



## WARNING



DO NOT operate machine until blade brake is adjusted and functioning properly. If blade stop time can not be achieved with the adjustment procedure described above, take machine immediately to an authorized Snapper dealer.

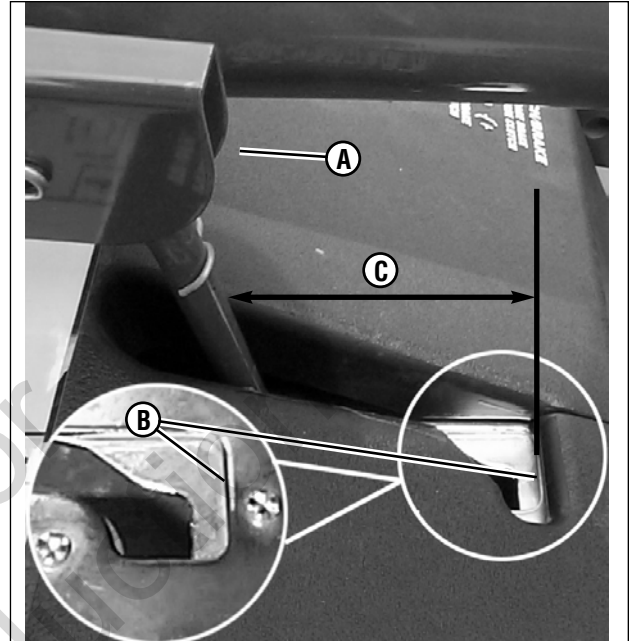

Figure 31: Measuring blade brake clearance

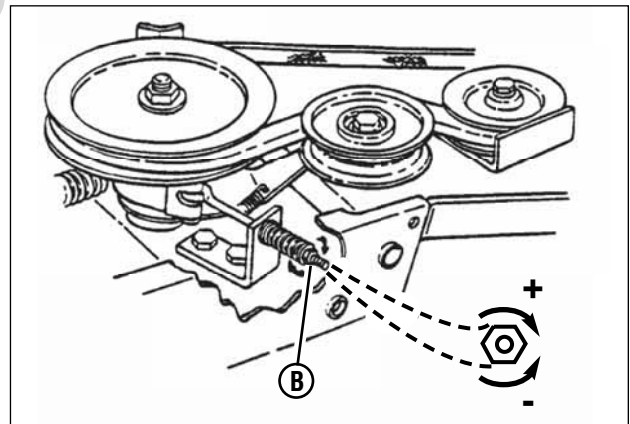

Figure 32: Adjusting blade brake tension





## WARNING



DO NOT attempt any adjustments, maintenance, service or repairs with the engine running. STOP engine. STOP blade. Engage parking brake. Remove key. Remove spark plug wire from spark plug and secure away from plug. Engine and components are HOT. Avoid serious burns, allow all parts to cool before working on machine. Fuel Filler Cap must be closed securely to prevent fuel spillage.

### Mower Deck Adjustment (Side-To-Side Levelness)

Before making deck leveling adjustments, check the tire pressure. Front tires 15 PSI, rear tires 12 PSI. If tires are properly inflated and mowing is still uneven, adjust side-to-side deck levelness.

1. Place the Rider on a smooth level surface.
2. Turn the engine off and remove the key. Remove the spark plug wire from the spark plug and secure the wire away from the plug.
3. Place a piece of angle iron, pipe, or similar object under the rear center of the deck.
4. Remove the rear hanger chains (**A, Figure 34**) and allow rear center of the deck to rest on the angle iron.
5. Measure the distance from the blade tips to the floor. If the measurement is within 1/8" from side-to-side, the deck attitude is satisfactory. If difference from side-to-side is greater than 1/8", continue with adjustment.
6. Loosen the hardware (**A, Figure 33**) that retains the left side of the blade pedal (**B**).
7. Move the lift arm (**C**) up or down as required until the blade tips are within 1/8" of each other.
8. Tighten the hardware loosened in Step 6. Recheck both sides of the deck for correct levelness.
9. Readjust the rear hanger chain pivots (**B, Figure 34**) to align with the holes in the support brackets (**D**).

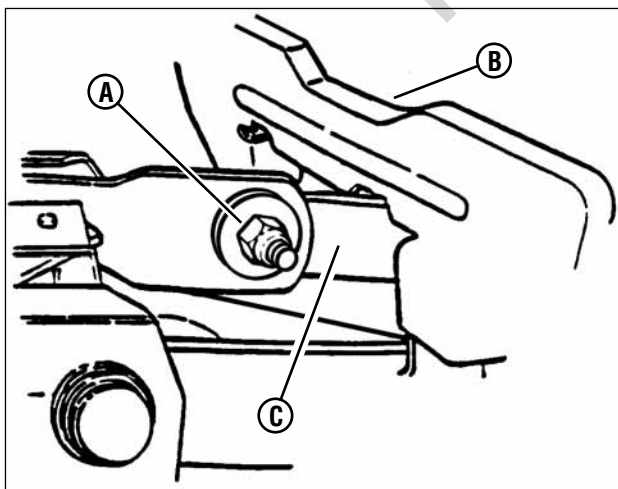

Figure 33: Adjusting deck levelness (side-to-side)  
(View of left lift arm from right side of machine)

10. Remove the angle iron, pipe, or similar object, and proceed to check front to rear levelness.

### Mower Deck Adjustment (Front-to-Rear Levelness)

#### 28" and 33" Decks

With the Rear Engine Rider on a smooth, level surface, rotate the blade until the blade tips are at the front and rear of the deck. Measure the distance from the blade tips to the floor (**Figure 34**). The distance should be the same, or the rear 1/8" to 1/4" lower than the front. If the rear blade tip is higher than the front, or is more than 1/4" lower than the front, proceed with adjustment.

#### 30" Decks

With the Rear Engine Rider on a smooth, level surface, rotate the blade until the blade tips are at the front and rear of the deck. Measure the distance from the blade tips to the floor (**Figure 34**). The distance should be the same, or the rear 1/8" to 1/4" higher than the front. If the rear blade tip is lower than the front, or is more than 1/4" higher than the front, proceed with adjustment.

#### Adjustment

1. Remove the rear hanger chains (**A, Figure 34**).
2. Turn each hanger pivot (**B**) the same number of rotations on the eye-bolt to raise or lower the rear of the deck.
3. Reinstall the rear hanger chains and measure the blade tips again.
4. Repeat Steps 1 through 3 until proper levelness is obtained.

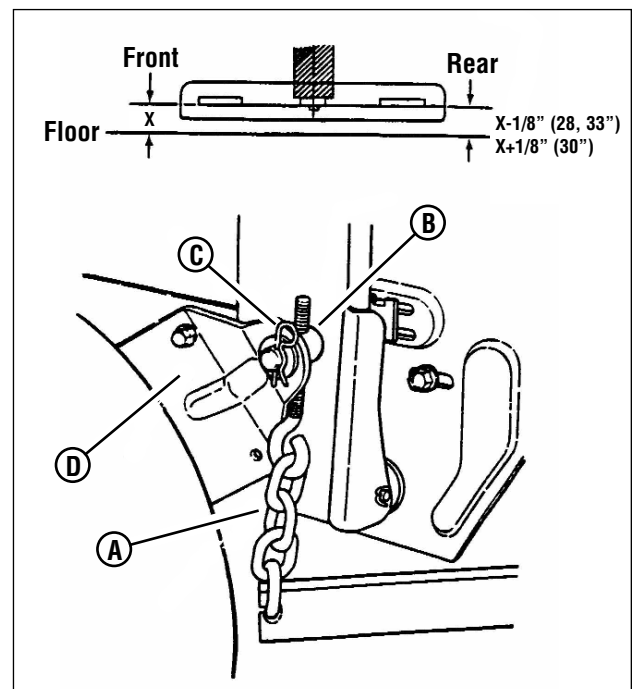

Figure 34: Adjusting the mower deck (front-to-rear)

# Maintenance



## WARNING



DO NOT attempt any adjustments, maintenance, service or repairs with the engine running. STOP engine. STOP blade. Engage parking brake. Remove key. Remove spark plug wire from spark plug and secure away from plug. Engine and components are HOT. Avoid serious burns, allow all parts to cool before working on machine. Fuel Filler Cap must be closed securely to prevent fuel spillage.

### Mower Drive Belt Adjustment (For 28" & 30" Decks Only)

1. Remove the mower drive belt cover. Refer to the section entitled "CHECK MOWER DRIVE BELT".
2. Move the blade lever up and over to the "ON" position.
3. Place the deck cutting height lever in the third position (middle notch). Measure the belt spacing (**B**, **Figure 35**) between the idler pulley (**A**) and belt. The distance should measure 1-1/4" but no less than 1".

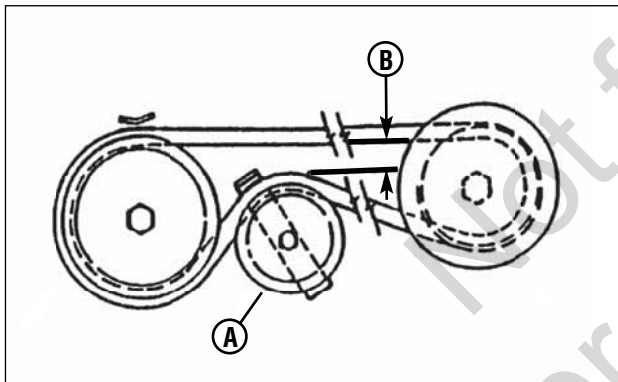

Figure 35: Measuring the belt spacing

4. If the distance is less than 1", adjust belt tension:
  - Move the blade lever to the "OFF" position.
  - Loosen the hardware (**A**, **Figure 36**) that secures the clamp that anchors the front frame assembly (**B**) to the rear main case.
  - Pull the front frame forward until the belt spacing, with the blade lever "ON", measures 1-1/4".
  - Retighten the hardware that secures the clamp. Make sure the hardware is tightened securely.

**IMPORTANT:** The SNAPPER Rear Engine Rider Models with 33" decks do not require belt tension adjustment. But, if the front frame assembly clamp is loosened for any reason, recheck the belt spacing between the idler pulley and belt. With the blade lever in the "ON" position, the distance should measure 1-3/4".

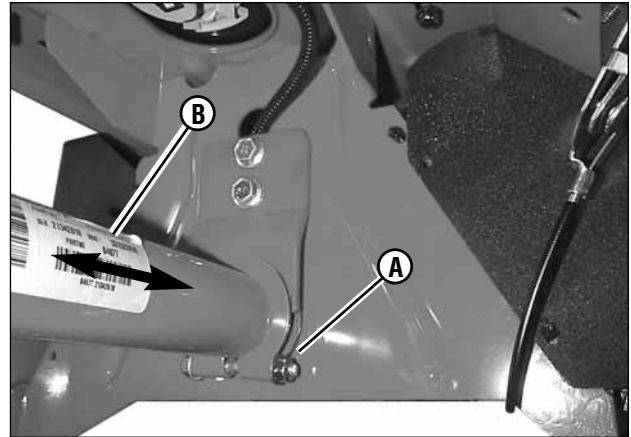

Figure 36: Mower belt adjustment

5. When belt adjustment is complete, it will be necessary to check Clutch/Brake Cable slack. Disengage the parking brake and allow the pedal (**A**, **Figure 37**) to remain in the engaged wheel drive (Up) position. The clutch/brake cable should have approximately 3/16" of slack. If the cable does not have slack adjustment of cable must be performed:
  - Peel back the rubber clutch/brake pedal pad and push one ferrule (**B**) through the hole (**C**) in the pedal to attain slack in the cable.
  - Recheck the cable for the approximate 3/16" of slack. Replace the pedal pad when adjustment is complete.

**IMPORTANT:** Too much slack may cause improper clutching, and braking could be affected. Too little slack may cause improper clutch function. Recheck the service brake/park brake and readjust if necessary. Refer to the section entitled "SERVICE BRAKE/PARK BRAKE ADJUSTMENT".

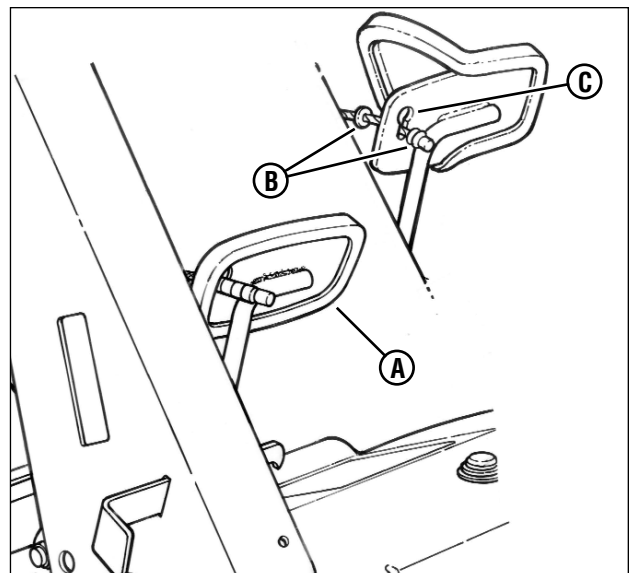

Figure 37: Clutch/brake cable adjustment



## WARNING



DO NOT attempt any adjustments, maintenance, service or repairs with the engine running. STOP engine. STOP blade. Engage parking brake. Remove key. Remove spark plug wire from spark plug and secure away from plug. Engine and components are HOT. Avoid serious burns, allow all parts to cool before working on machine. Fuel Filler Cap must be closed securely to prevent fuel spillage.

## Rear Engine Rider Drive Components

### Service Brake / Park Brake Adjustment

Test the wheel brake on a dry concrete surface. When properly adjusted, the Rear Engine Rider will stop within 5 feet from fastest speed. If stopping distance is more than 5 feet, the wheel brake should be adjusted as follows:

1. Follow the WARNING statement found on this page.
2. Carefully stand the Rear Engine Rider on its rear bumper. (See statement below.)
3. Depress the clutch/brake pedal (A, Figure 38) all the way down. Move and hold the park brake lever (B) in the "ON" position and release the clutch/brake pedal to set the park brake.

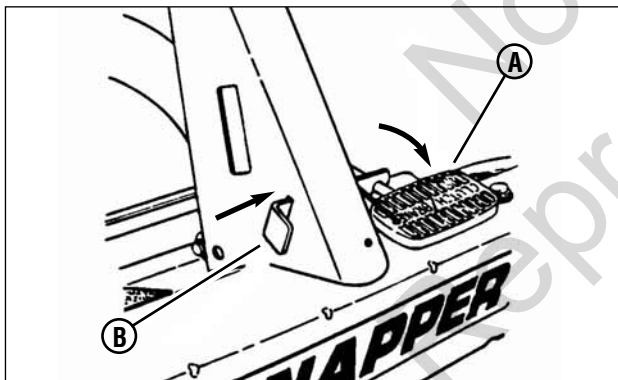

Figure 38: Setting the park brake

## IMPORTANT

To avoid damaging the emissions system:

- Do not overfill the fuel tank. Stop filling the tank when fuel collects in the filler neck.
- Empty the fuel tank before standing the machine on its rear bumper.

4. Measure the distance (A, Figure 39) between the end of the clutch/brake cable (B) and the bottom of the housing (C). The measurement should be 3/4".

NOTE: The cotter pin, brake spring, and clutch yoke (D, E, and F, Figure 39) are noted for reference purposes only.

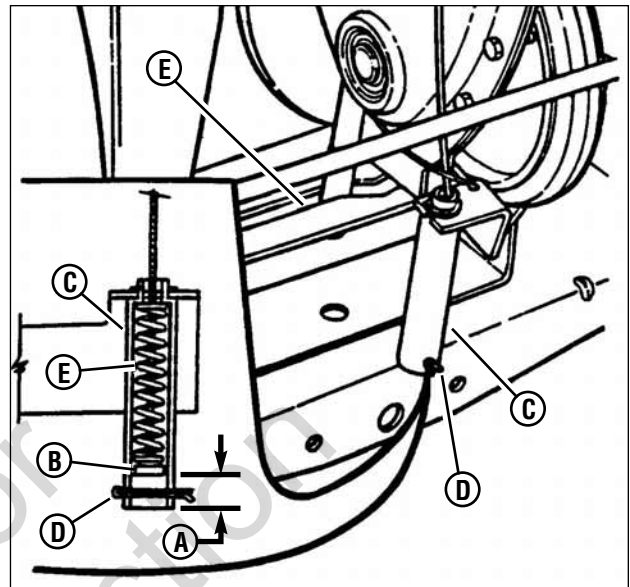

Figure 39: Adjusting the brake cable

5. If the measurement is not 3/4", loosen the two jam-nuts (A, Figure 40). Hold the clutch/brake cable (B) to the chain case bracket.
6. Adjust the cable up or down using the jam-nuts to obtain a distance of 3/4" between the end of the clutch/brake cable (adjustment shown in inset of Figure 40) and the bottom of the housing.
7. After adjustment is complete, securely tighten the cable jam-nuts.
8. Retest the wheel brake.

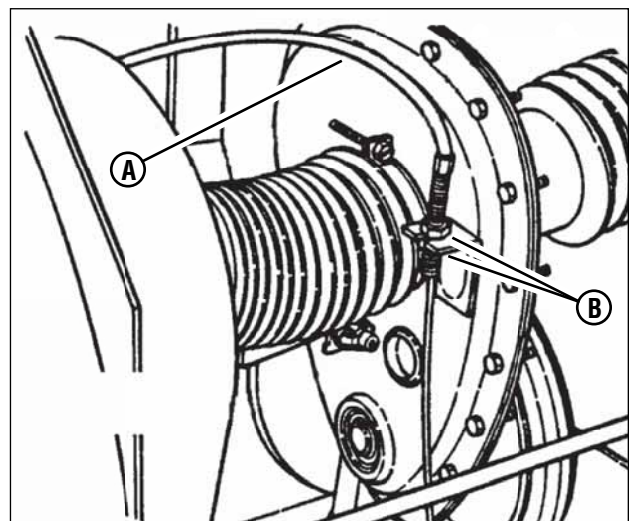

Figure 40: Brake cable adjusting nuts

# Maintenance



## WARNING



DO NOT attempt any adjustments, maintenance, service or repairs with the engine running. STOP engine. STOP blade. Engage parking brake. Remove key. Remove spark plug wire from spark plug and secure away from plug. Engine and components are HOT. Avoid serious burns, allow all parts to cool before working on machine. Fuel Filler Cap must be closed securely to prevent fuel spillage.

## Mower Blade Replacement

### Blade Wear Limits

1. Inspect the blade frequently for signs of excessive wear or damage (**Figure 41**):  
(**A**) New blade;  
(**B**) Wear limit (notch starts);  
(**C**) Dangerous condition - do not use on mower!  
Replace with new blade.

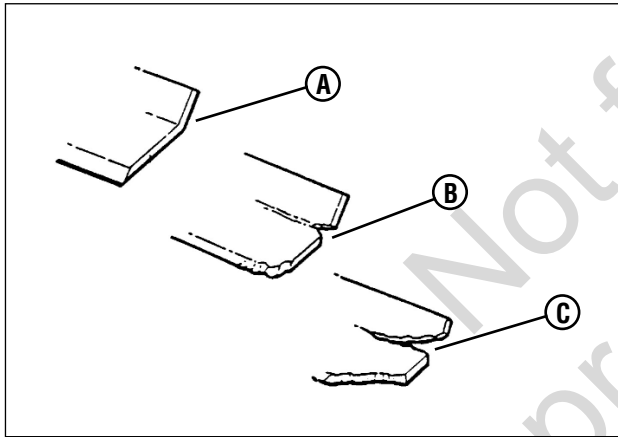

Figure 41: Mower blade wear limits



## WARNING



Wear heavy leather gloves when handling or working around cutting blades. Blades are extremely sharp and can cause severe injury. DO NOT use a cutting blade that shows signs of excessive wear or damage.

### Blade Sharpening

1. Follow the WARNING statement found on this page.
2. Carefully stand the Rear Engine Rider on its rear bumper.
3. Remove the bolts (**B**, **Figure 42**), washers (**C**) and nuts (**D**) securing the mower blade (**A**) to the spindle.
4. Inspect the condition of the blade (**Figure 41**).
5. If the blade is in good condition, sharpen at 22 to 28 degrees (**B**, **Figure 43**). DO NOT sharpen beyond existing cutting edge (**A**).
6. Check blade balance after sharpening. If necessary, correct blade balance by grinding the heavy end of the blade.

7. Reinstall the blade. Torque the blade mounting bolts to the recommended range of 30 to 40 ft. lbs.

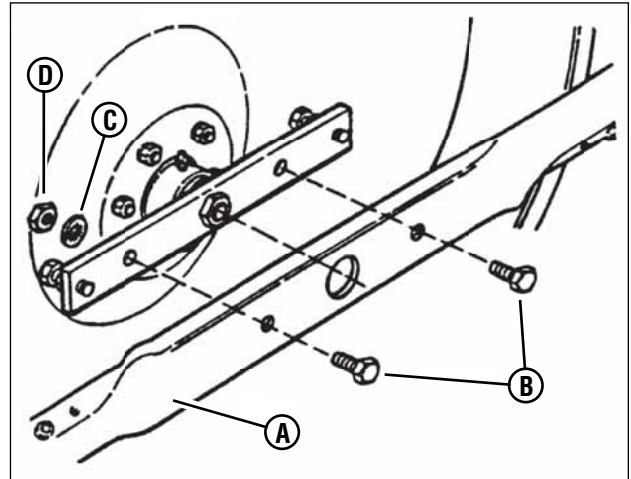

Figure 42: Removing the mower blade

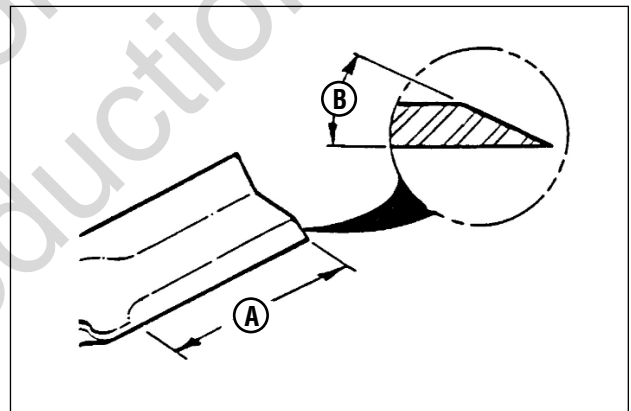

Figure 43: Sharpening the mower blade

## IMPORTANT

To avoid damaging the emissions system:

- Do not overfill the fuel tank. Stop filling the tank when fuel collects in the filler neck.
- Empty the fuel tank before standing the machine on its rear bumper.





## WARNING



DO NOT attempt any adjustments, maintenance, service or repairs with the engine running. STOP engine. STOP blade. Engage parking brake. Remove key. Remove spark plug wire from spark plug and secure away from plug. Engine and components are HOT. Avoid serious burns, allow all parts to cool before working on machine. Fuel Filler Cap must be closed securely to prevent fuel spillage.

## Mower Drive Belt Replacement

Inspect the mower drive belt as described in the section, "CHECK MOWER DRIVE BELT". Replace the belt if signs of excessive wear and/or damage are present.

### Belt Removal

1. Remove the mower drive belt cover. Refer to the section entitled "DRIVE BELT COVER REMOVAL".
2. Remove the old belt.

### Belt Replacement

1. Follow the WARNING statement found on this page.
2. Carefully stand the Rear Engine Rider on its rear bumper.
3. Route the new belt through the engine belt guide (B, Figure 44) up to the engine pulley (A).

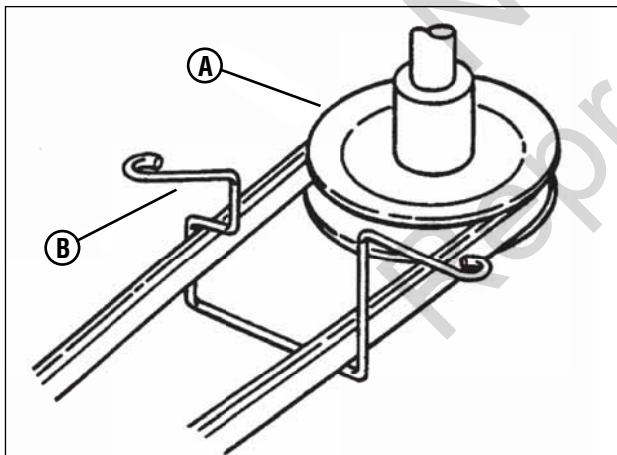

Figure 44: Engine pulley and belt guide

4. Move the transmission shift lever to the neutral (N) position.
5. Rotate the clutch yoke (F, Figure 39) out with your hand and work the belt between the drive disc and the rubber driven disc.
6. To clear the primary chain case, move the transmission shift lever to the #5 position. Route the belt around the drive disc and into the drive pulley belt groove.
7. Remove the idler (A, Figures 45 and 46).
8. Route the belt onto the spindle pulley (C). Make sure the belt is inside the spindle belt guide (D) and the idler belt guide (B). Route the belt as shown.

9. Reinstall the idler removed in Step 8. The idler belt guide tab should be positioned in the hole located on the idler arm. Tighten the idler pulley bolt securely.
10. Adjust the belt guide to allow 1/16" belt-to-belt guide clearance (E).
11. Check the mower drive belt tension and adjust if necessary (28" & 30" decks only). Refer to the Section entitled "MOWER DRIVE BELT ADJUSTMENT".
12. Reinstall the mower drive belt cover.

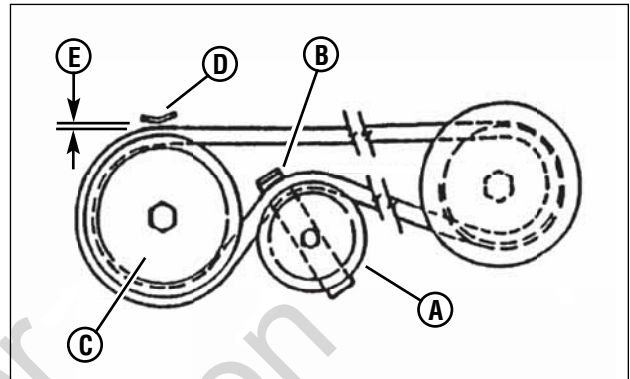

Figure 45: Belt routing for 28 and 30 inch decks

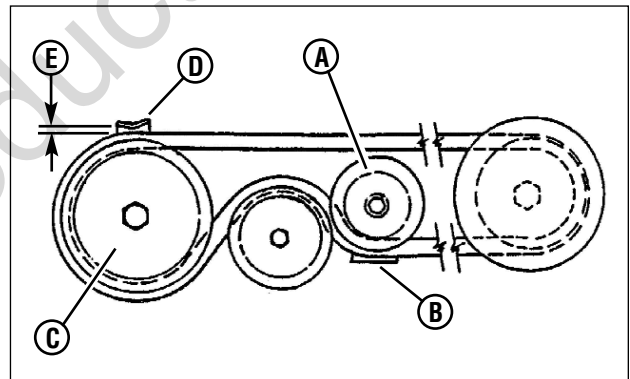

Figure 46: Belt routing for 33 inch decks

## IMPORTANT

To avoid damaging the emissions system:

- Do not overfill the fuel tank. Stop filling the tank when fuel collects in the filler neck.
- Empty the fuel tank before standing the machine on its rear bumper.

# Maintenance



## WARNING



DO NOT attempt any adjustments, maintenance, service or repairs with the engine running. Stop engine. Stop blade. Engage parking brake. Remove key. Remove spark plug wire from spark plug and secure away from plug. Engine and components are HOT. Avoid serious burns, allow all parts to cool before working on machine. Fuel Filler Cap must be closed securely to prevent fuel spillage. DO NOT attempt to charge the battery while it is installed on the machine.

## Battery

### Battery Removal

1. Carefully pull each side of the battery cover (A, Figure 47) away from the ratchet fasteners (B) and remove the cover.

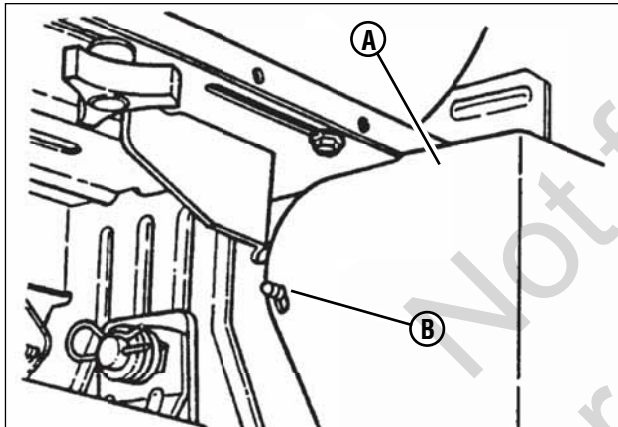

Figure 47: Battery cover

2. Remove the hardware (A, Figure 48) securing the battery holddown bracket (B), and remove the bracket.

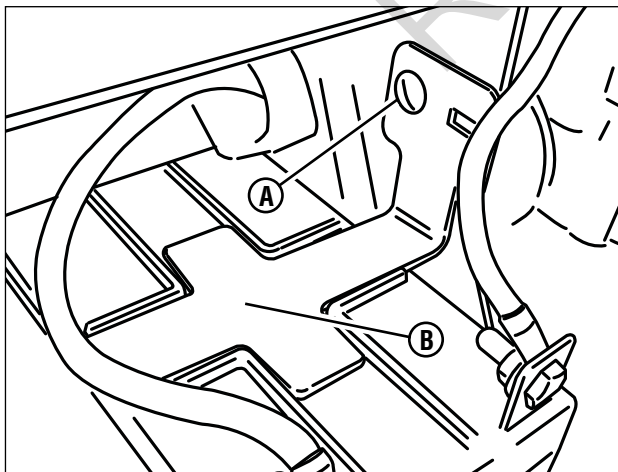

Figure 48: Battery holddown bracket

3. Disconnect the BLACK (Negative) cable (C, Figure 49) from the negative battery terminal. Retain the mounting hardware.



## WARNING



Always disconnect the BLACK negative (-) battery cable first.

4. Disconnect the RED (Positive) cable (B) from the positive battery terminal. Retain the mounting hardware.
5. Remove the battery from the battery compartment.

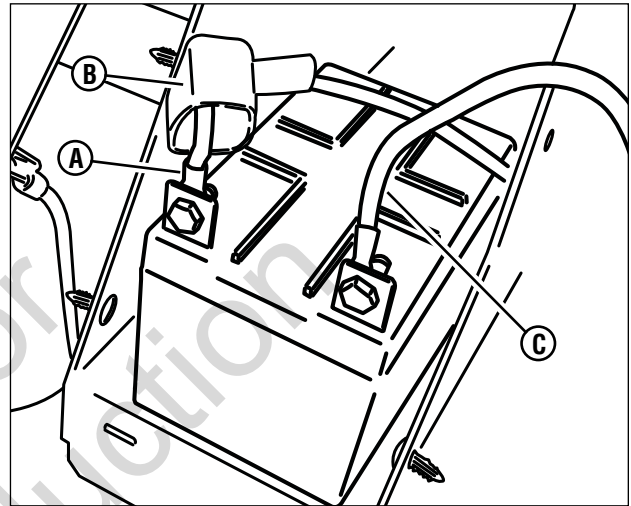

Figure 49: Battery connections

### Battery Installation

1. Slide the battery into the battery compartment.
2. Connect the RED positive (+) cable (A, Figure 49) to the positive terminal (+) on the battery with the removed hardware.



## WARNING



Always connect the RED positive (+) battery cable first.

3. Connect the black negative (-) cable (C) to the negative terminal (-) on the battery with the removed hardware.
4. Apply a small amount of grease over the terminals to prevent corrosion.
5. Reinstall the positive terminal cover (B) over the positive terminal.
6. Reinstall the battery holddown bracket (B, Figure 48), securing with the removed hardware (A).
7. Reinstall the battery cover (A, Figure 47).



## WARNING



Always shield the positive terminal with the positive terminal cover.

## Battery Charging

- A. Place the battery in a well-ventilated area.
- B. Connect a 12-volt **constant-voltage** battery charger to the battery terminals; RED to positive (+) and BLACK to negative (-) terminal.
- C. Charge the battery for 2 to 4 hours.



### WARNING



The battery on this unit requires the use of a constant voltage (CV) battery charger designed for valve regulated (sealed) non-spillable batteries. Attempting to use a standard battery charger may result in damage to the battery. DO NOT use “BOOST” chargers on the battery. DO NOT attempt to charge the battery while installed on the unit.

## Battery Storage

If the mower is to be stored out of season on its rear bumper, it is recommended the battery be removed, charged and stored.

1. Remove the battery. Refer to the section entitled “BATTERY REMOVAL”.
2. Charge the battery. Refer to the section entitled “BATTERY CHARGING”.
3. Store the battery in an area away from the rider on a wood surface. DO NOT STORE THE BATTERY ON A CONCRETE SURFACE.

Not for  
Reproduction

# Troubleshooting

PROBLEM	PROBABLE CAUSE	CORRECTIVE ACTION
Engine Will Not Start Using Recoil Starter	1. Fuel tank empty.	1. Fill fuel tank with fresh fuel to proper level.
	2. Engine needs choking.	2. Move choke control to "CHOKE" position.
	3. Spark plug wire disconnected.	3. Place spark plug wire onto spark plug.
	4. Faulty parking brake, blade or ignition switch.	4. Contact authorized dealer.
	5. Park brake not engaged.	5. Engage park brake.
	6. Ignition is in the OFF position.	6. Turn ignition switch to the RUN position.
Engine Will Not Start Using Electric Starter	1. Fuel tank empty.	1. Fill fuel tank with fresh fuel to proper level.
	2. Engine needs choking.	2. Move choke control to "CHOKE" position.
	3. Spark plug wire disconnected.	3. Place spark plug wire onto spark plug.
	4. Faulty parking brake, blade or ignition switch.	4. Contact authorized dealer.
	5. Park brake not engaged.	5. Engage park brake.
	6. Blown Fuse.	6. Replace with new 20 AMP fuse.
	7. Faulty interlock module.	7. Contact authorized dealer.
	8. Ignition is in the OFF position.	8. Turn ignition switch to the START position.
	9. Battery is weak or dead.	9. Charge or replace with new battery.
	10. Battery cables loose, broken disconnected or corroded.	10. Clean and connect battery cables. If broken, replace with new battery cables.
	11. Faulty electric starter or starter solenoid.	11. Contact authorized dealer.
	12. Starter cable loose, broken or disconnected.	12. Connect starter cable. If broken, replace with new starter cable.
	13. Electrical wiring harness disconnected or broken.	13. Connect or replace with new wiring harness.
Engine Stalls After Running	1. Operator not in seat.	1. Sit in operator's seat.
	2. Choke control in the "CHOKE" position.	2. Move choke control to "OFF" position.
	3. Fuel tank empty.	3. Fill fuel tank with fresh fuel to proper level.
	4. Engine air pre-cleaner and or air cleaner dirty.	4. Clean free of all debris.
	5. Spark plug defective or gap set improperly.	5. Service spark plug.
	6. Fuel filter restricted.	6. Replace fuel filter.
	7. Water, debris or stale fuel in fuel system.	7. Drain and clean fuel system.
Engine Loses Power	1. Excessive load on engine.	1. Lessen load.
	2. Engine air pre-cleaner or air cleaner dirty.	2. Clean or replace filters.
	3. Spark plug faulty.	3. Service spark plug.
	4. Water, debris or stale fuel in fuel system.	4. Drain and clean fuel system. Replace filter.
	5. Debris build up on engine cooling screen.	5. Clean all debris from engine cooling screen.
Engine Backfires When Turned To "STOP"	1. Throttle control set too "FAST".	1. Set throttle control to "SLOW" and allow engine to idle. Then, turn key to "OFF".
Excessive Vibration	1. Damaged, out of balance or bent mower blades.	1. Service mower blade(s).
	2. Loose blade components.	2. Service and tighten loose parts.
	3. Loose or missing air lift (if equipped).	3. Replace air lifts. Tighten to proper torque.
	4. Lumpy or frayed belt.	4. Replace belt.
	5. Bent Idler, stationary or spindle pulley.	5. Replace pulley.



## Troubleshooting

PROBLEM	PROBABLE CAUSE	CORRECTIVE ACTION
Rider Will Not Move Or Loss of Traction	1. Drive disc worn or damaged.	1. Replace drive disc.
	2. Rubber drive disc is not tracking properly on drive disc.	2. Adjust rubber drive disc.
	3. Tapered axle bolt and nut missing.	3. Replace with tapered bolt & nut.
	4. Axle bearing seized.	4. Contact authorized dealer.
	5. Insufficient lubrication in chain case or transmission/differential.	5. Contact authorized dealer.
Blade(s) Not Cutting	1. Blade engagement lever in the "OFF" position.	1. Move lever to the "ON" position.
	2. Mower belt slipping.	2. Adjust or replace mower belt.
	3. Cutting blade is dull, worn or damaged.	3. Sharpen or replace cutting blade.
Cutting Grass Improperly	1. Uneven tire pressure.	1. Bring to proper pressure. 15 PSI front tire & 12 PSI rear tire.
	2. Cutting height too low or high.	2. Adjust cutting height.
	3. Engine speed too slow.	3. Move throttle control to "FAST" position.
	4. Forward speed too fast.	4. Move transmission shift lever to a slower speed.
	5. Terraced cut, side to side.	5. Adjust side to side level.
	6. Excessive deck pitch, front to rear.	6. Adjust front to rear pitch.
	7. Cutting blade(s) dull or damaged.	7. Sharpen cutting edges or replace blade(s).
	8. Mower belt slipping.	8. Adjust tension or replace mower belt.
Poor Grass Discharge	1. Engine speed too slow.	1. Move throttle control to "FAST" position.
	2. Forward speed too fast.	2. Move transmission shift lever to a slower speed.
	3. Grass is wet.	3. Mow when grass is dry.
	4. Excessively dull, worn or damaged blade(s).	4. Service mower blade.
	5. Build up of grass clippings and debris under deck.	5. Clean the underside of deck.
	6. Improper blade installed on deck.	6. Install proper blades.
Oil Leaking	1. Leaking chain case or differential plugs.	1. Verify plugs are not cracked & are in good shape. Check gaskets.
	2. Leaking engine block.	2. Contact authorized dealer.

# Warranty

## BRIGGS & STRATTON POWER PRODUCTS GROUP, L.L.C. OWNER WARRANTY POLICY

### LIMITED WARRANTY

Briggs & Stratton Power Products Group, LLC will repair and/or replace, free of charge, any part(s) of the equipment that is defective in material or workmanship or both. Briggs & Stratton Corporation will repair and/or replace, free of charge, any part(s) of the Briggs and Stratton engine\* (if equipped) that is defective in material or workmanship or both. Transportation charges on product submitted for repair or replacement under this warranty must be borne by purchaser. This warranty is effective for the time periods and subject to the conditions stated below. For warranty service, find the nearest Authorized Service Dealer using our dealer locator at [www.BriggsandStratton.com](http://www.BriggsandStratton.com) or [www.Snapper.com](http://www.Snapper.com).

There is no other express warranty. Implied warranties, including those of merchantability and fitness for a particular purpose, are limited to one year from purchase or to the extent permitted by law. Liability for incidental or consequential damages are excluded to the extent exclusion is permitted by law.

Some states or countries do not allow limitations on how long an implied warranty lasts, and some states or countries do not allow the exclusion or limitation of incidental or consequential damages, so the above limitation and exclusion may not apply to you. This warranty gives you specific legal rights and you may also have other rights which vary from state to state or country to country.

### WARRANTY PERIOD

Item	Consumer Use	Commercial Use:
Equipment	2 Years	90 Days
Engine*	2 Years	90 Days
Battery	1 Year	1 Year

The warranty period begins on the date of purchase by the first retail consumer or commercial end user, and continues for the period of time stated above. "Consumer use" means personal residential household use by a retail consumer. "Commercial use" means all other uses, including use for commercial, income producing or rental purposes. Once product has experienced commercial use, it shall thereafter be considered as commercial use for purposes of this warranty.

No warranty registration is necessary to obtain warranty on Briggs & Stratton products. Save your proof of purchase receipt. If you do not provide proof of the initial purchase date at the time warranty service is requested, the manufacturing date of the product will be used to determine warranty eligibility.

### ABOUT YOUR WARRANTY

We welcome warranty repair and apologize to you for being inconvenienced. Warranty service is available only through servicing dealers authorized by Briggs & Stratton or BSPPG, LLC.

Most warranty repairs are handled routinely, but sometimes requests for warranty service may not be appropriate. This warranty only covers defects in materials or workmanship. It does not cover damage caused by improper use or abuse, improper maintenance or repair, normal wear and tear, or stale or unapproved fuel.

**Improper Use and Abuse** - The proper, intended use of this product is described in the Operator's Manual. Using the product in a way not described in the Operator's Manual or using the product after it has been damaged will void your warranty. Warranty is not allowed if the serial number on the product has been removed or the product has been altered or modified in any way, or if the product has evidence of abuse such as impact damage, or water/chemical corrosion damage.

**Improper Maintenance or Repair** - This product must be maintained according to the procedures and schedules provided in the Operator's Manual, and serviced or repaired using genuine Briggs & Stratton parts. Damage caused by lack of maintenance or use of non-original parts is not covered by warranty.

**Normal Wear** - Like all mechanical devices, your unit is subject to wear even when properly maintained. This warranty does not cover repairs when normal use has exhausted the life of a part or the equipment. Maintenance and wear items such as filters, belts, cutting blades, and brake pads (engine brake pads are covered) are not covered by warranty due to wear characteristics alone, unless the cause is due to defects in material or workmanship.

**Stale Fuel** - In order to function correctly, this product requires fresh fuel that conforms to the criteria specified in the Operator's Manual. Damage caused by stale fuel (carburetor leaks, clogged fuel tubes, sticking valves, etc) is not covered by warranty.

\* Applies to Briggs and Stratton engines only. Warranty coverage of non-Briggs and Stratton engines is provided by the engine manufacturer.

# SLOPE GUIDE

SIGHT AND HOLD THIS GUIDE LEVEL WITH A VERTICAL TREE, A CORNER OF A STRUCTURE, A POWER LINE POLE, OR A FENCE.

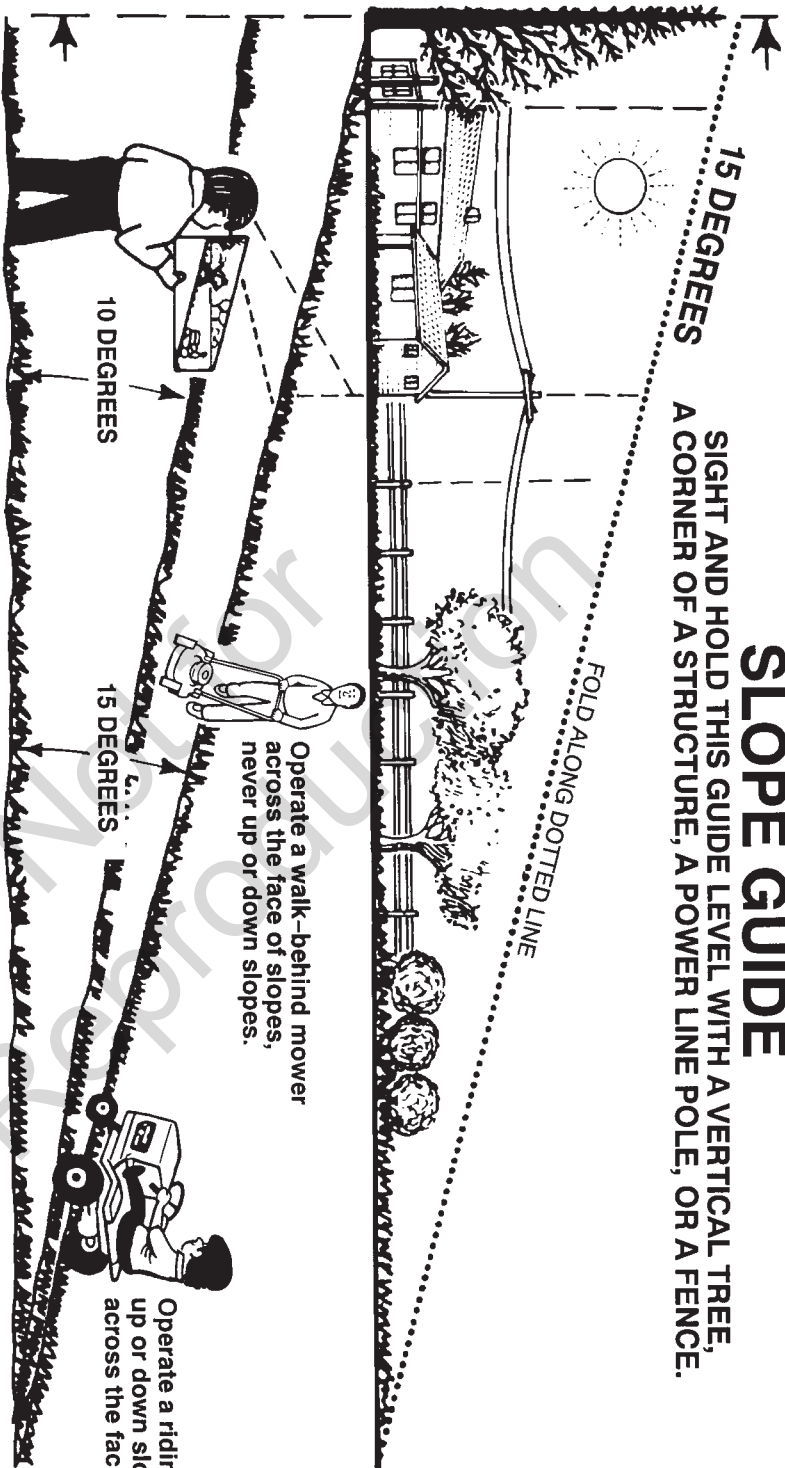

On a riding mower to determine if a slope is safe to mow: (1) disengage the blade(s), (2) put the unit in reverse, and (3) try to back straight up the slope. If you can back up the slope, it is generally safe to mow. However, if you do not feel safe, or if you are not completely sure, use this guide and do not mow a slope that is greater than 15 degrees. If the riding mower is used with a pull-behind or rear mounted attachment, do not operate the unit on a slope that is greater than 10 degrees.

A 15 degree slope is a hill that increases in height at approximately 2.5 feet in 10 feet.  
 A 10 degree slope is a hill that increases in height at approximately 1.7 feet in 10 feet.



Use extreme care at all times, and avoid sudden turns or maneuvers. Follow other instructions in this manual for safety in mowing on slopes. Operate a riding mower up or down slopes, never across the face of slopes. Operate a walk-behind mower across the face of slopes, never up or down slopes. Use extra care when operating on or near slopes and obstructions.

# SNAPPER®

## REAR ENGINE RIDING MOWER SERIES 24

---

Product Specifications	2811524BV	2812524BVE	3014524BVE	3317524BVE
Deck Size (inches)	28	28	30	33
Height of Cut (inches)	1.5 - 4.0	1.5 - 4.0	1.5 - 4.0	1.5 - 4.0
Transmission Type	5-Spd Disc	5-Spd Disc	5-Spd Disc	5-Spd Disc
Ground Speed-Fwd/Rev (mph)	1.0-4.6 / 0-1.9	1.0-4.6 / 0-1.9	1.0-4.6 / 0-1.9	1.0-4.6 / 0-1.9
Engine Power (hp)	11.5	12.5	14.5	17.5
Engine Displacement (cc)	344	344	344	502
Fuel Tank Capacity (qt)	7	7	7	7

### Common Service Parts

### Part Number

Cutter Blade (28")	7104196
Cutter Blade (30")	7026565
Cutter Blade (33")	7034168
Cutting Deck Belt (28 and 30")	7022252
Cutting Deck Belt (33")	7043844

---

### Power Rating

The gross power rating for individual gas engine models is labeled in accordance with SAE (Society of Automotive Engineers) code J1940 (Small Engine Power & Torque Rating Procedure), and rating performance has been obtained and corrected in accordance with SAE J1995 (Revision 2002-05). Torque values are derived at 3060 RPM; horsepower values are derived at 3600 RPM. Net power values are taken with exhaust and air cleaner installed whereas gross power values are collected without these attachments. Actual gross engine power will be higher than net engine power and is affected by, among other things, ambient operating conditions and engine-to-engine variability. Given the wide array of products on which engines are placed, the gas engine may not develop the rated gross power when used in a given piece of power equipment. This difference is due to a variety of factors including, but not limited to, the variety of engine components (air cleaner, exhaust, charging, cooling, carburetor, fuel pump, etc.), application limitations, ambient operating conditions (temperature, humidity, altitude), and engine-to-engine variability. Due to manufacturing and capacity limitations, Briggs & Stratton may substitute an engine of higher rated power for this Series engine.