

# Atlas Copco

FX 150N, FX 180N, FX 225N, FX 270N

## Instruction book

Original instructions

### COPYRIGHT NOTICE

Any unauthorized use or copying of the contents or any part thereof is prohibited.

This applies in particular to trademarks, model denominations, part numbers and drawings.

This instruction book is valid for CE as well as non-CE labelled machines. It meets the requirements for instructions specified by the applicable European directives as identified in the Declaration of Conformity.

2020 - 10

No. 9828093399 00

[www.atlascopco.com](http://www.atlascopco.com)

The Atlas Copco logo consists of the brand name 'Atlas Copco' in a stylized, italicized serif font. It is positioned between two thick, solid black horizontal bars, one above and one below the text.

Code	
<b>9828093399</b>	<b>00</b>
Edit. 10/2020	

## INSTRUCTION AND MAINTENANCE MANUAL

# DRYERS

FX 150N, FX 180N, FX 225N, FX 270N

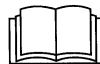
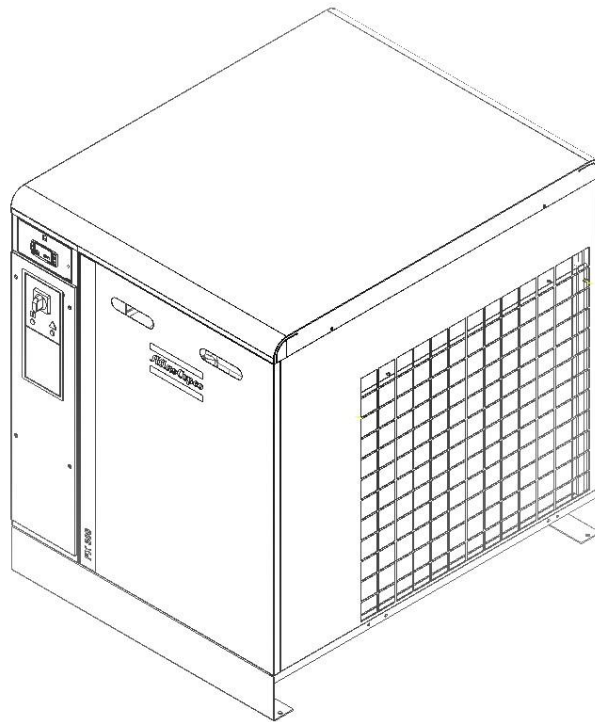

**READ THIS MANUAL CAREFULLY BEFORE CARRYING OUT ANY OPERATIONS ON THE DRYER.**

**CONTENTS****PART A: INFORMATION FOR THE USER**

- 1.0 GENERAL CHARACTERISTICS
- 2.0 INTENDED USE
- 3.0 OPERATION
- 4.0 GENERAL SAFETY STANDARDS
- 5.0 DESCRIPTION OF DANGER SIGNALS
- 6.0 DANGER ZONES
- 7.0 SAFETY DEVICES
- 8.0 POSITION OF PLATES
- 9.0 DRYERS ROOM
- 10.0 TRANSPORT AND HANDLING
- 11.0 UNPACKING
- 12.0 INSTALLATION
- 13.0 DIMENSIONS AND TECHNICAL DATA
- 14.0 MACHINE ILLUSTRATION
- 15.0 SCRAPPING THE DRYERS

**PART B: INFORMATION RESERVED FOR TECHNICALLY SKILLED PERSONNEL**

- 16.0 PARTIAL ROUTINE MAINTENANCE
- 17.0 TROUBLE-SHOOTING AND EMERGENCY REMEDIES
- 18.0 STARTING UP, FREE CONTACT FEATURES

**ATTENTION: THERE IS A COPY OF THE WIRING DIAGRAM INSIDE THE ELECTRIC PANEL**

**ADDRESSES OF ASSISTANCE CENTRES**

In the event of breakdown or malfunction of the dryer, switch it off and do not tamper with it. If repairs are needed, apply only to a technical assistance centre approved by the manufacturer and insist on the use of original spare parts. Failure to comply with the above may endanger the safety of the machine.

**INTRODUCTION**

**Keep this manual with care for future consultation; the use and maintenance manual is an integral part on the dryer. Read this manual carefully before carrying out any operations on the dryer.**

**The installation of the dryer and all operations involving it must be performed in conformity with the regulations in force concerning electric plants and personal safety.**

**CHARACTERISTICS AND SAFETY PRECAUTIONS**

**BEFORE REMOVING THE PROTECTIVE GUARDS TO CARRY OUT ANY MAINTENANCE ON THE MACHINE, SWITCH OFF THE ELECTRIC POWER SUPPLY AND DISCHARGE THE RESIDUAL PRESSURE INSIDE THE UNIT.  
ALL WORK ON THE ELECTRIC PLANT, HOWEVER SLIGHT, MUST BE CARRIED OUT BY PROFESSIONALLY SKILLED PERSONNEL.**

The manufacturer does not accept responsibility for damage caused as a result of negligence or failure to abide by the instructions given above.

**THIS MACHINE IS NOT SUITABLE FOR EXTERNAL INSTALLATION**

**THIS MACHINE CORRESPOND TO THE ESSENTIAL SAFETY REQUIREMENTS FORESEEN FROM THE EUROPEAN STANDARD (2006/42 CE).**

**THE LUBRICATING LIQUIDS AND OTHER EVENTUAL FLUIDS MUST NOT BE DISCHARGED IN THE ENVIRONMENT. THESE POLLUTING AND HAZARDOUS PRODUCTS MUST COMPULSORY BE DISPOSED BY CHARGING AUTHORISED AND SPECIALISED FIRMS ACCORDING TO THE DIFFERENT TYPOLOGY OF PRODUCT.**

**DIFFERENTIATE THE COMPRESSOR COMPONENTS ACCORDING TO THE DIFFERENT CONSTRUCTION MATERIALS (PLASTIC, COPPER, IRON, OIL FILTER, AIR FILTER ECC...)**

**1.0 GENERAL CHARACTERISTICS**

The dryer is a chilling machine with direct expansion and dry evaporator.  
The air to be dried is sent to the heat exchanger in which the water vapour present is condensed: the condensate gathers in the separator and is discharged outside through a steam trap.

**2.0 INTENDED USE**

The dryer has been built to dry the compressed air for industrial use. The dryer cannot be used in premises where there is a risk of fire or explosion or where work is carried out which releases substances into the environment which are dangerous with regard to safety (for example: solvents, inflammable vapours, alcohol, etc.).  
In particular the appliance cannot be used to produce air to be breathed by humans or used on direct contact with foodstuffs. These uses are allowed if the compressed air produced is filtered by means of a suitable filtering system (Consult the manufacturer for these special uses.)  
This appliance must be used only for the purpose for which it was specifically designed. All other uses are to be considered incorrect and therefore unreasonable. The Manufacturer cannot be held responsible for any damage resulting from improper, incorrect or unreasonable use.

**3.0 OPERATION**

The gaseous refrigerant coming from the evaporator (4) is sucked by the refrigeration compressor (1) and it is pumped into the condenser (2). This one allows its condensation, eventually with the help of the fan (3); the condensed refrigerant passes through the dewatering filter (8) and it expands through the capillary tube (7) and goes back to the evaporator where it produces the refrigerating effect. Due to the heat exchange with the compressed air which passes through the evaporator against the stream, the refrigerant evaporates and goes back to the compressor for a new cycle.  
The circuit is equipped with a bypass system for the refrigerant; this intervenes to adjust the available refrigerating capacity to the actual cooling load. This is achieved by injecting hot gas under the control of the valve (9): this valve keeps constant the pressure of the refrigerant in the evaporator and therefore also the dew point never decreases below 0 °C in order to prevent the condensate from freezing inside the evaporator. The dryer runs completely automatically.

**DRYER FLOW DIAGRAM**

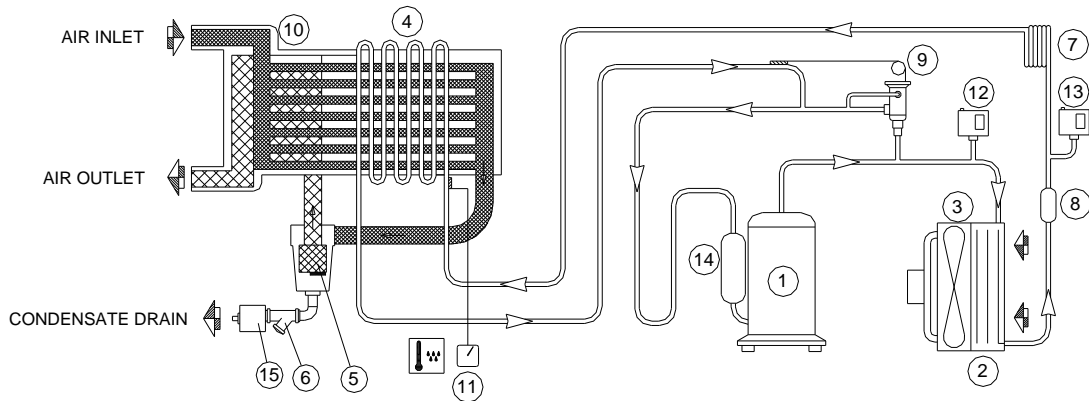

1) REFRIGERANT COMPRESSOR	9) HOT GAS BYPASS VALVE
2) CONDENSER	10) AIR-TO-AIR EXCANGER
3) MOTOR FAN	11) DIGITAL CONTROLLER
4) EVAPORATOR	12) MAX PRESSURE SWITCH
5) DEMISTER CONDENSATE SEPARATOR	13) FAN CONTROL PRESSURE SWITCH
6) IMPURITY TRAP	14) LIQUID SEPARATOR
7) EXPANSION CAPILLARY TUBE	15) CONDENSATE DRAIN
8) REFRIGERANT FILTER	





**4.0 GENERAL SAFETY STANDARD**

The appliance may be used only by specially trained and authorized personnel.  
Any tampering with the machine or alterations not approved beforehand by the Manufacturer relieve the latter of responsibility for any damage resulting from the above actions.  
The removal of or tampering with the safety devices constitutes a violation of the European Standards on safety.



**ALL WORK ON THE ELECTRIC PLANT, HOWEVER SLIGHT, MUST BE CARRIED OUT BY PROFESSIONALLY SKILLED PERSONNEL.**

5.0 DESCRIPTION OF DANGER SIGNALS

				
1) Dangerous electricvoltage	2) Air not fit for breathing	3) High pressure	4) Fan rotating	5) Hot parts

6.0 DANGER ZONES

6.1 DANGER ZONES

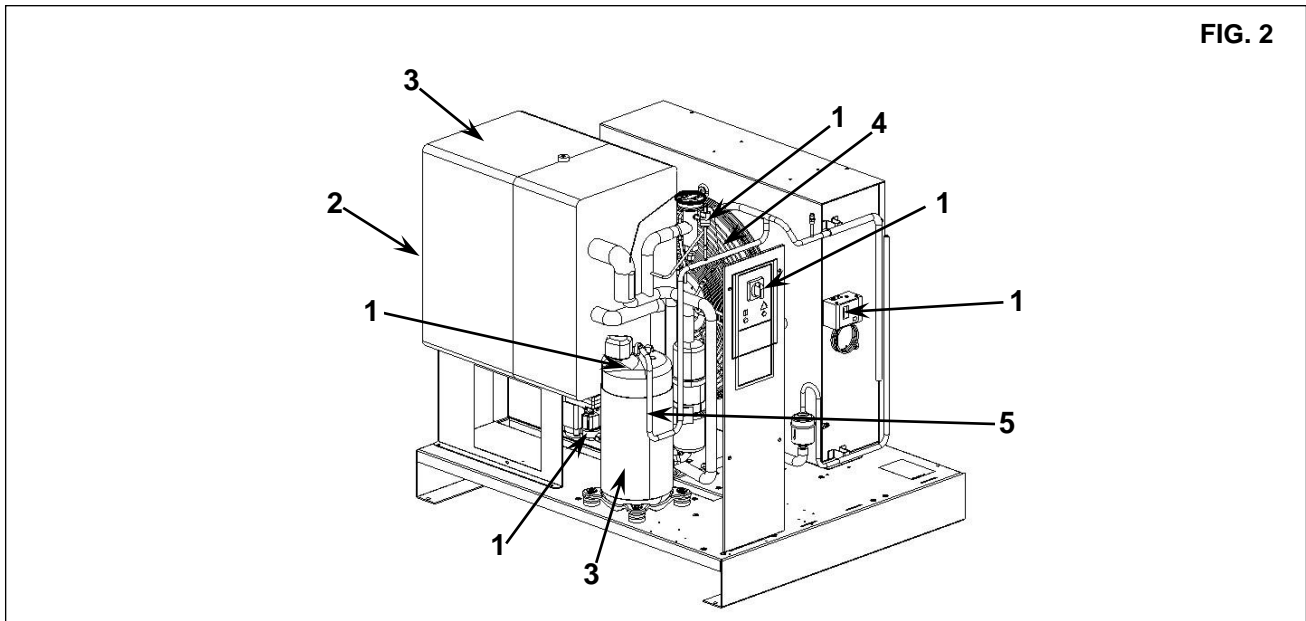
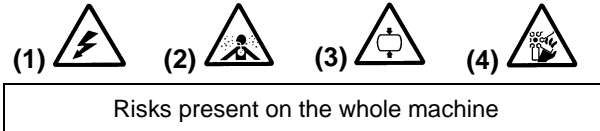

FIG. 2

7.0 SAFETY DEVICES

7.1 SAFETY DEVICES

1) Cooling fan shield	3) Earth
2) high pressure side switch	

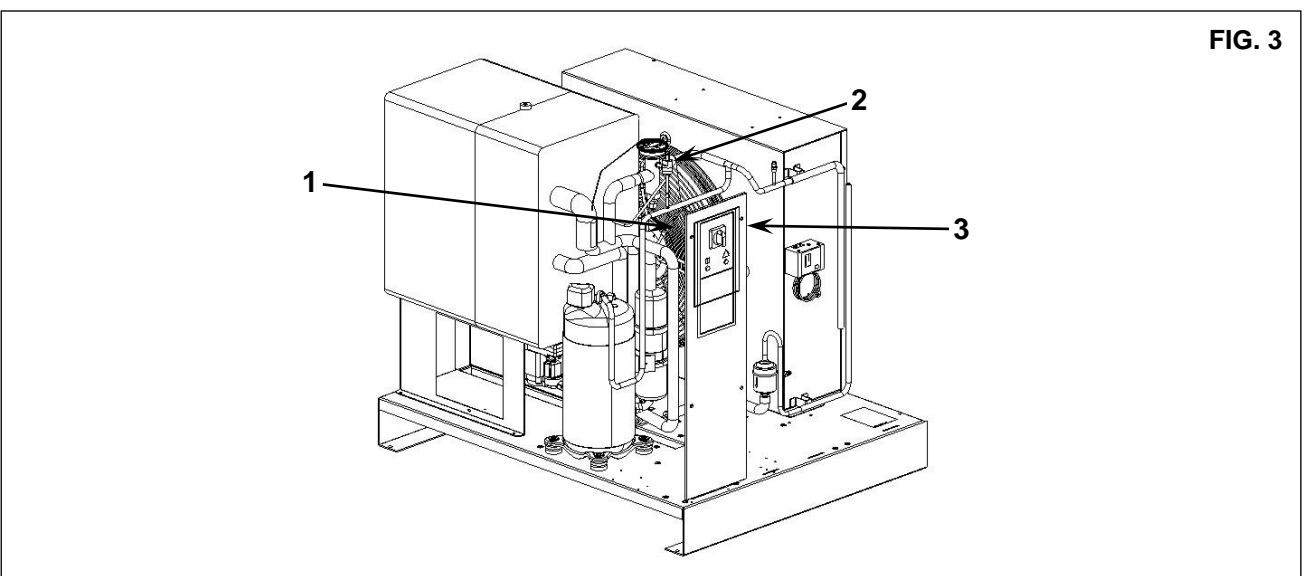

FIG. 3

**8.0 POSITION OF PLATES**

**8.1 POSITION OF THE DANGER PLATES (Fig. 4)**

The plates fitted on the compressor unit are part of the machine; they have been applied for safety purposes and must not be removed or spoiled for any reason.

Ref.1 - Spare plate Code 1079 9903 48

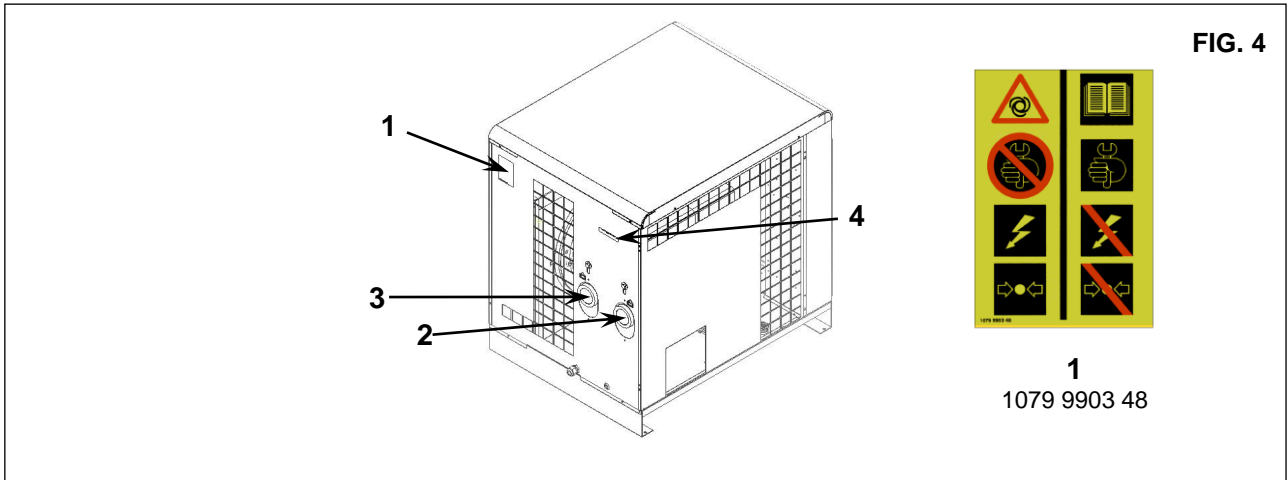

**8.2 POSITION OF THE DATA PLATES (Fig. 4)**

Ref. 2) "IN"	Ref. 4) Identification plate
Ref. 3) "OUT"	

**9.0 DRYERS ROOM**

**9.1 FLOOR**

The floor must be even and of industrial type; the total weight of the machine is shown in Fig. 5

Remember the total weight of the machine when positioning it.

**9.2 VENTILATION**

The choice of an appropriate room will prolong the life of your dryer; the room must be spacious, dry, well ventilated and free from dust.

The operating conditions to be complied with are the following:

Min. room temperature: + 3 °C (+37,4 °F) (compulsory)	Min. inlet allowed temperature: 3°C (+37,4 °F)
Max. room temperature: + 45 °C (+113 °F) (compulsory)	Max. working pressure: 14 bar (203 psi)
Max. temperature of incoming air: 55 °C (+131 °F)	

- Please keep environmental conditions stable (temperature and humidity) in order to avoid refrigerant compressor/fan overload and/or reduction of dryer performance. Similar failures shall affect warranty reimbursements.
- Please ensure the appropriate composition of the air within the machine room: - clean with no damaging contaminants (e.g., dust, fibers, fine sand) - free of explosive or chemically unstable gases or vapors - free of acid/alkaline forming substances, particularly ammonia, chlorine or hydrogen sulfide. Similar failures shall affect warranty reimbursements.
- Please remember that we do not recommend the application of duct to extract air in presence of axial fans.

**10.0 TRANSPORT AND HANDLING**

The machine must be transported as shown in the following figures.

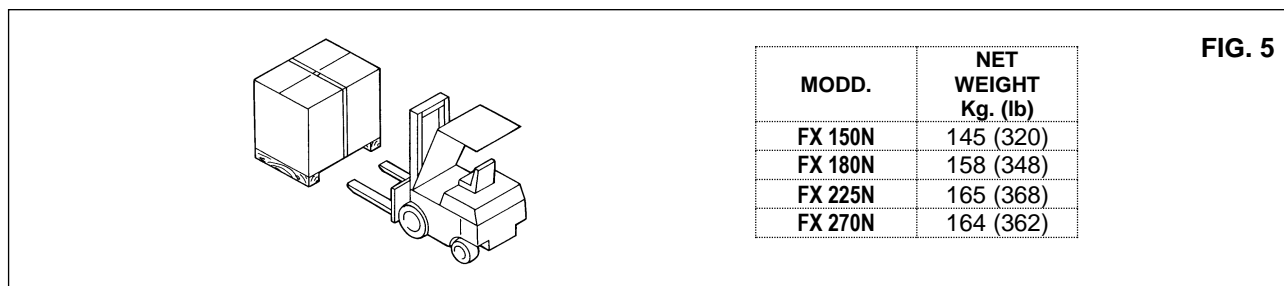
**11.0 UNPACKING**

**CUTTING THE METAL STRAPPING IS A DANGEROUS OPERATION, DO NOT ABANDON THE CUT PIECES IN THE ENVIRONMENT.**

After removing the packing, ensure that the machine is unbroken and that there are no visibly damaged parts.

If you are in doubt, do not use the machine but apply to the manufacturer technical assistance service or to your dealer.

The packing material (plastic bags, polystyrene foam, nails, screws, wood, metal strapping, etc.) must not be left within the reach of children or abandoned in the environment, as they are a potential source of danger and pollution. Dispose of these materials in the approved collection centres.

**12.0 INSTALLATION**

**12.1 POSITIONING**

After unpacking the equipment and preparing the dryers room, put the machine into position, checking the following items:

- ensure that there is sufficient space around the machine to allow maintenance (see Fig. 6).

**ENSURE THAT THE OPERATOR CAN SEE THE WHOLE MACHINE FROM THE CONTROL PANEL AND CHECK THE PRESENCE OF ANY UNAUTHORIZED PERSONS IN THE VICINITY OF THE MACHINE.**

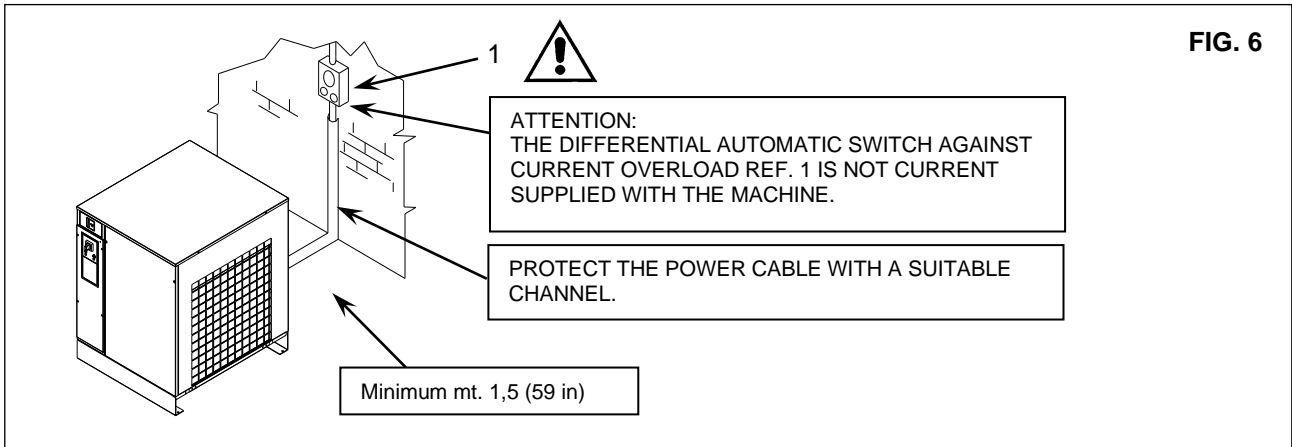

**FIG. 6**

**12.2 ELECTRICAL CONNECTION**

- Check that the supply voltage is the same as the value indicated on the machine data plate.
- Check the condition of the line leads and ensure that there is an efficient earth lead.
- **Ensure that there is an automatic cut-out device upstream for the machine against overcurrents, with a differential device ( Ref. 1 Fig. 6 ), wiring diagram.**



**ONLY PROFESSIONALLY SKILLED PERSONNEL MAY HAVE ACCESS TO THE ELECTRIC PANEL. SWITCH OFF THE POWER BEFORE OPENING THE DOOR OF THE ELECTRIC PANEL. COMPLIANCE WITH THE REGULATIONS IN FORCE CONCERNING ELECTRIC PLANTS IS FUNDAMENTAL FOR OPERATOR SAFETY AND FOR THE PROTECTION OF THE MACHINE.**

**12.3 CONNECTION TO THE COMPRESSED AIR NETWORK**

Fit a manual interception valve Ref. 1 between the machine and the compressed air network so that the dryer may be isolated during maintenance operations (see figure 7 ).

Drainage of condensate Rif. 2 Fig. 7 (automatic) are led outside the machine with a flexible pipe that may be inspected. Drainage must comply with the local regulations in force.

- All refrigerant dryers shall be equipped with proper pre-filter at closest position to dryer air inlet (to be replaced according to service plan: once per year or even before in case of particular high humidity ambient conditions).



**ALL DAMAGE DUE TO THE FAILURE TO COMPLY WITH THESE INDICATIONS CANNOT BE ATTRIBUTED TO THE MANUFACTURER AND MAY CAUSE INVALIDITY OF THE GUARANTEE CONDITIONS.**

**12.4 STARTING UP**

See part B of this manual, Chapter 16.0

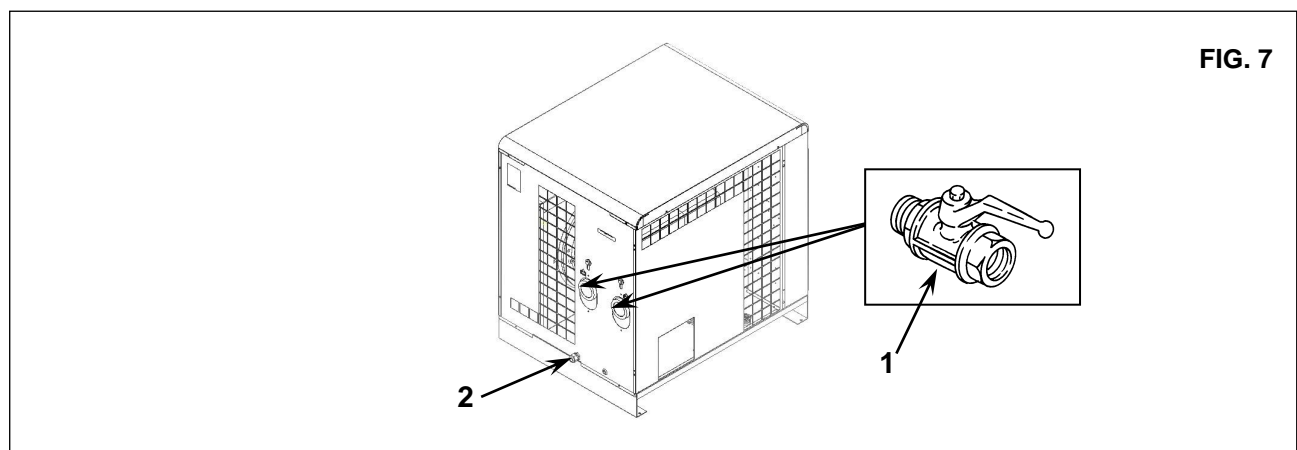

**FIG. 7**



13.0 DIMENSIONS AND TECHNICAL DATA

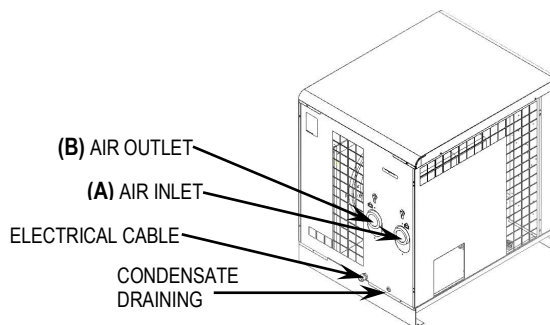
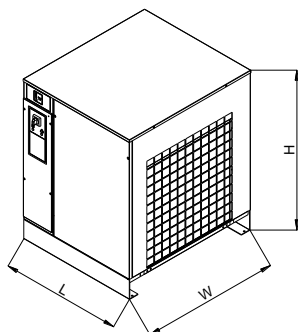



TYPE	L (mm / in)	W (mm / in)	H (mm / in)
FX 150N	800 (31.7)	1045 (41)	1001 (37.87)
FX 180N	800 (31.7)	1045 (41)	1001 (37.87)
FX 225N	800 (31.7)	1045 (41)	1001 (37.87)
FX 270N	800 (31.7)	1045 (41)	1001 (37.87)

Refrigerant gas <sup>(1)</sup>	GWP <sub>100</sub> <sup>(2)</sup>
R-410A	2088

(1) According to ISO 817  
(2) According to EN-378-1

TYPE	A	B
FX 150N	2" F.	2" F.
FX 180N	2" F.	2" F.
FX 225N	2"1/2 F.	2"1/2 F.
FX 270N	2"1/2 F.	2"1/2 F.

MODD.	WEIGHT Kg. (lb.)	Freon R410A Kg. Kg. (lb.) 60 Hz	 Nominal Power W (HP) 60 Hz	 Nominal Power W (HP) 60 Hz	 Bar (psi) MAX. 60 Hz
FX 150N	145 (320)	1,5 (3,31)	2090 (2,80)	210 (0,28)	14 (203)
FX 180N	158 (348)	1,5 (3,31)	2440 (3,27)	780 (1,046)	14 (203)
FX 225N	165 (368)	1,85 (4,08)	2440 (3,27)	780 (1,046)	14 (203)
FX 270N	164 (362)	1,95 (4,3)	3300 (4,42)	1100 (1,48)	14 (203)

Reference conditions:	50 Hz	60 Hz	Limit conditions:	60 Hz
Ambient temperature	25 °C	38 °C (+100°F)	Max. ambient temperature	46 °C (115°F)
Inlet air temperature	35 °C	38 °C (+100°F)	Min. ambient temperature	5 °C (41°F)
Working pressure	7 bar	7 bar (101,5 psi)	Max. inlet air temperature	60 °C (140°F)
			Max. working pressure	14 bar (203 psi)

14.0 MACHINE ILLUSTRATION  
14.1 GENERAL LAY-OUT

1	Refrigerant compressor	7	Freon filter
2	Condenser	8	Capillary
3	Motor fan	9	Pressure switch of motor fan
4	Evaporator	10	Pressure switch of the high pressure
5	Condensate drain	11	Liquid separator
6	Hot gas by pass valve		

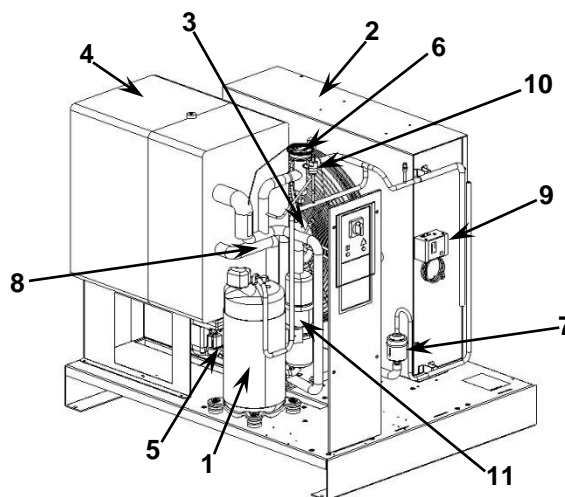
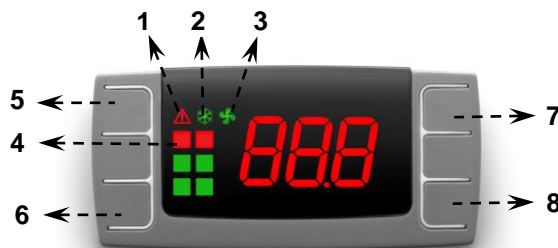

FIG. 8

14.2 DIGITAL CONTROLLER



Identification



Front panel of the controller

Reference	Name
1	Alarm icon
2	Refrigerant compressor icon
3	Fan icon
4	Alarm LED
5	Button to snooze or to reset the alarm
6	SET button
7	UP button
8	DOWN button
6+7	Back to previous screen
6+8	Menu

Icons

Icon	Name	Mode	Function
	Alarm	Off	No active alarms
		On	Probe failure alarm
		On	High temperature or low temperature alarm
	Refrigerant compressor	On	Dryer on
		Flashing + SE	Maintenance warning
		Flashing + L2	Dewpoint too low Dryer is stopped
	Fan	Off	Fan off
		Flashing	Not applicable
		On	Fan on

15.0 SCRAPPING THE UNIT

If the machine is to be scrapped, it must be dismantled into parts of the same material, to be disposed of according to the local regulations in force.

ALWAYS RESPECT THE REGULATIONS IN FORCE FOR DISPOSING OF OLD OIL AND OTHER POLLUTING MATERIALS SUCH AS INSULATING FOAM, ETC.

## PART "B"



**THIS PART "B" OF THE INSTRUCTIONS MANUAL IS RESERVED FOR PROFESSIONALLY SKILLED PERSONNEL APPROVED BY THE MANUFACTURER.**

### 16.0 PARTIAL ROUTINE MAINTENANCE



BEFORE CARRYING OUT ANY MAINTENANCE JOBS IT IS OBLIGATORY TO STOP THE MACHINE AND DISCONNECT IT FROM THE POWER MAINS AND FROM THE COMPRESSED AIR DISTRIBUTION NETWORK.

#### 16.1 MAINTENANCE SCHEDULE

These maintenance intervals are recommended for work environments that are not dusty and are well ventilated. For particularly dusty environments, double the frequency of controls.

Every week	■ ■	Brush/blow off the finned surface of the condenser
	■ ■	Clean the filter of the automatic condensate drain
Every 2000 hours / 1 year	■ ■	Replace the filter of automatic condensate drain (2902016102)
Every 4000 hours / 2 year	■ ■	Replace drain kit (2200902017)

#### 16.2 CLEANING OF THE AUTOMATIC CONDENSATE DISCHARGER FILTER (Fig. 10)

Clean the filter of the steam trap.

Proceed as follows:

- Close the cock Ref. 1 Fig. 10
- Release the pressure in the dryer by pressing the condensate drain "TEST" pushbutton located on the steam trap Ref. 2 Fig. 10.
- Switch off the machine. Turn the switch in position STOP Ref. 3 Fig. 10
- Turn on the supply automatic differential switch Ref. 4 Fig. 10



#### HOT PARTS INSIDE

- To use the hole Ref. 5
- Remove the stopper Ref. 6
- Remove the filter Ref. 7
- Clean the filter Ref. 5 with a jet of air, working from inside to outside
- Install the filter, fix the plug Ref. 7 - 6
- Close the panels Ref. 5

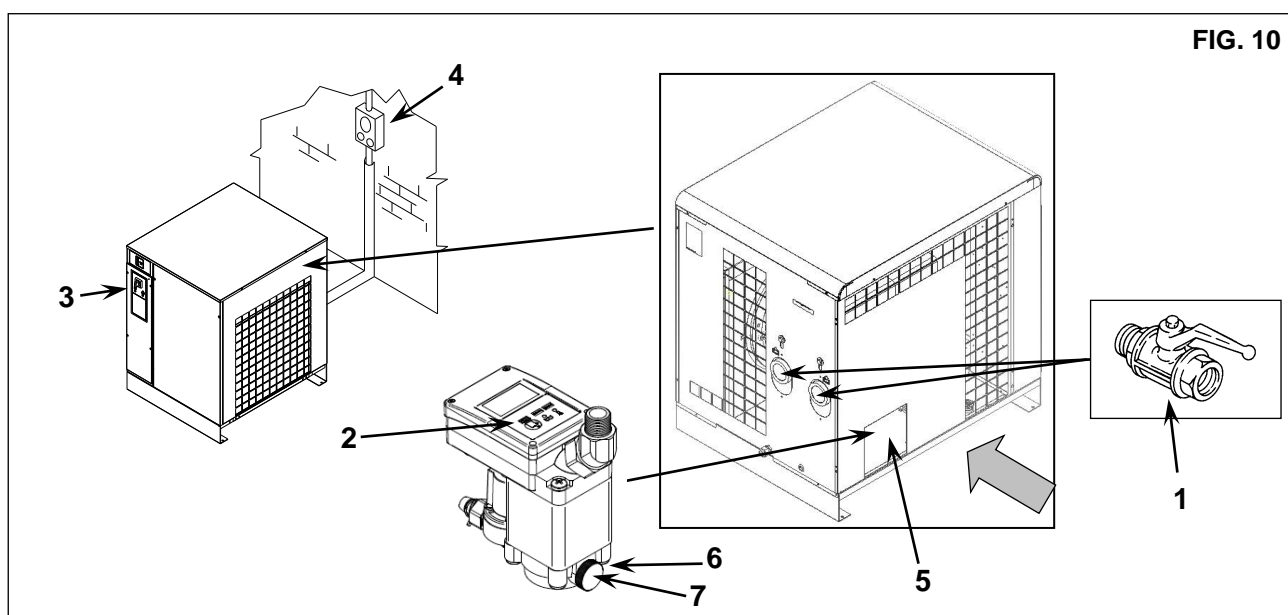

FIG. 10

**16.3 CLEANING THE CONDENSER (Fig. 10)**

The condenser must be cleaned every month.

Proceed as follows:

- Switch off the machine. Turn the switch in position STOP Ref. 3 Fig. 10
- Turn on the supply automatic differential switch Ref. 4 Fig. 10
- To use the hole Ref. 5 Fig. 10
- Clean the condenser fins Ref. 1 with compressed air (Fig. 10) **DO NOT USE WATER OR SOLVENTS**
- Close the panels Ref. 5 Fig. 10

**17.0 TROUBLE-SHOOTING AND EMERGENCY REMEDIES**



**ALL WORK MUST BE CARRIED OUT BY PROFESSIONALLY SKILLED PERSONNEL. BEFORE CARRYING OUT ANY MAINTENANCE JOBS IT IS OBLIGATORY TO STOP THE MACHINE AND DISCONNECT IT FROM THE POWER MAINS.**

**N.B. OPERATIONS MARKED ■ ■ MUST BE CARRIED OUT BY PROFESSIONALLY SKILLED PERSONNEL APPROVED THE MANUFACTURER**

FAULT FOUND	POSSIBLE CAUSES	OBSERVATIONS
1) No compressed air passes through the dryer outlet	1A) The pipes are frozen inside	<ul style="list-style-type: none"> <li>■ ■ -The bypass valve of the hot gas is broken or out-of-calibration</li> <li>-The room temperature is too low and the evaporators piping are obstructed with ice</li> </ul>
2) Presence of condensate in the pipings.	2A) The condensate separator does not work correctly  2B) The dryer is working outside its rating  2C) The dryer is working under bad conditions of condensation	<ul style="list-style-type: none"> <li>-Clean the filter from the condensate drain</li> <li>■ ■-Check the condensate drain</li> <li>-Check the flow rate of treated air</li> <li>-Check the room temperature</li> <li>-Check the air temperature at the drier inlet.</li> <li>-Clean the condenser.</li> <li>■ ■-Check the operation and the calibration of the press. switch</li> <li>■ ■-Check the good operation of the fan.</li> </ul>
3) The compressor head is very hot (> 55 °C)	Make reference to 2B Make reference to 2C 3A) The cooling circuit is not working with the right gas charge	<ul style="list-style-type: none"> <li>■ ■ -Check if there are leaks of refrigerating gas.</li> <li>■ ■ - Charge it again.</li> </ul>
4) Motor cuts out on overload	Make reference to 2B Make reference to 2C Make reference to 3A	
5) The motor hums and does not start.	Sequence relays switched on The line voltage is too low. You switched the machine off and on again without leaving enough time for the pressure balancing. The starting system of the motor is defective.	<ul style="list-style-type: none"> <li>- Exchange two phases of main supply</li> <li>-Contact the electric power company</li> <li>-Wait a few minutes before starting the machine again.</li> <li>■ ■ -Check the running and starting relays and condensers (if any)</li> </ul>
6) The machine has stopped and does not restart even after a few minutes.	The thermostatic protection with <b>manual reset</b> has intervened: make reference to 2B-2C-3A.  The motor has burnt out.	
7) The compressor is very noisy.	Troubles with the internal mechanical parts or with the valves	

### 17.1 REMOTE ALARM FUNCTION



The controller allows to remotely visualize a number of alarms. This is managed by two potential free contact NC (Normally Closed).The contacts opens in case of an alarm.

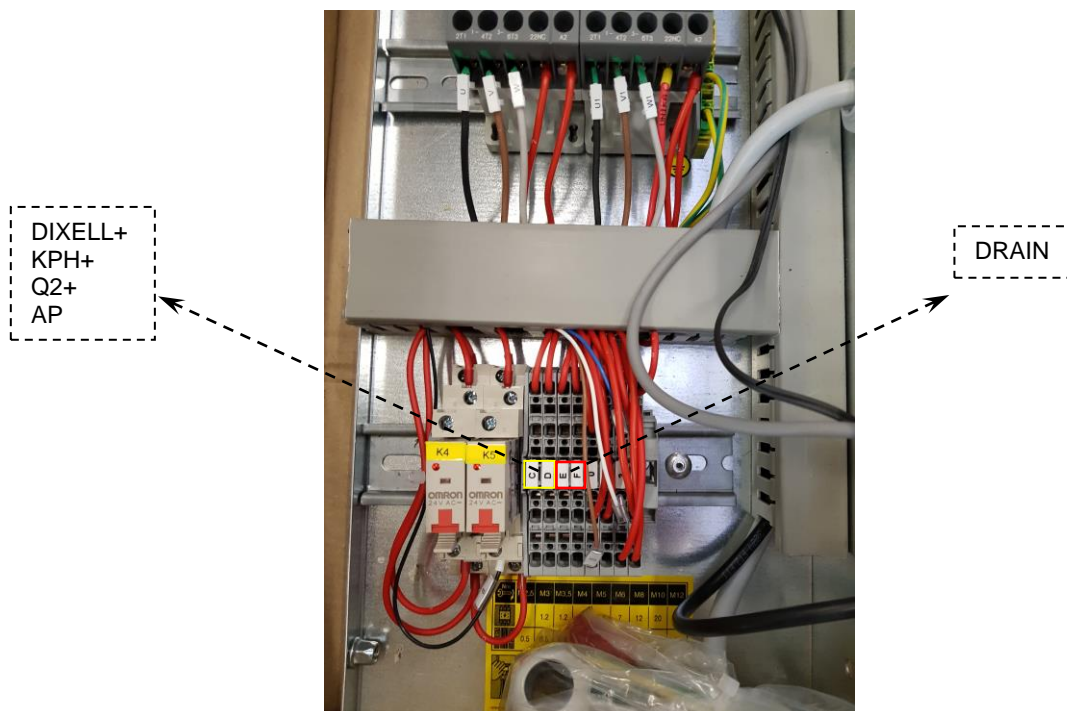



- **CD contact** : it's in series to all the alarms from the controller ( see the section "fault messages"), to the fan motor breaker Q2, to the phase sequency relay KPH and to the safety pressure switch AP. The contact opens when one of the fault happens.
- **EF contact** : it's in series to the alarms coming from the drain. The contact opens when one of the fault happens.



Free contact location

### FAULT MESSAGES

Flashing fault message	Description	Remedy
 84759D	Dewpoint temperature probe failure	Replace the probe
 84865D	Refrigerant compressor discharge temperature probe failure	Replace the probe
 84762D	Pressure dewpoint too high	Refer to the fault and remedies section

Flashing fault message	Description	Remedy
 <p>84765D</p>	Pressure dewpoint too low. Refrigerant compressor shut down	Refer to the fault and remedies section
 <p>84864D</p>	Refrigerant compressor discharge temperature too high; refrigerant compressor stopped.	Refer to the fault and remedies section
 <p>84766D</p>	Internal EPROM error (not removable)	Reset by pressing one of the four buttons. If the problem persists, replace the controller
 <p>84767D</p>	Maintenance required (not removable)	Perform the maintenance and reset the alarm

**RESETTING THE MAINTENANCE WARNING**



*Front panel of the controller*

To reset the maintenance warning, follow steps 1 to 12:

1. The display is flashing between standard view (dewpoint) and maintenance required (SE) alarm.
2. Push and hold buttons SET (6) and DOWN (8) to enter the menu.
3. Message "SE" appears on display.



4. Push and release the UP button (7).
5. Message "rS" appears on display.



6. Push and release the SET button (6).
7. Message "n" appears on display.



84774D

8. Push and release the UP button (7).
9. Message "y" appears on display.



84776D

10. Push and release SET (6) to reset service alarm.
11. Message "y" blinks for 3 seconds.



84776D

12. Then "rL" is fixed and "C" blinks on display for about 10 seconds.



84778D

The service alarm is now reset.

## SETTING THE SERVICE INTERVAL

To set the service interval, follow steps 1 to 9:

1. PDP is showing standard view.
2. Push and hold buttons SET (6) and DOWN (8) to enter the menu.
3. Message "SE" appears on display.



84770D

4. Push and release SET (6) to enter the "SE" menu.
5. Current service interval is displayed.  
("60" or any other value between "0" and "99")



84781D

6. Select desired service interval using the UP and DOWN button.  
(40=4000h, 55=5500h, 80=8000h,...)
7. Push and release SET to confirm the new service interval.
8. The selected value blinks during 3 seconds.



9. Then “rS” is fixed and “°C” blinks on display for about 10 seconds.



The new service interval is now set.

**FREEZE PROTECTION FUNCTION**

Once the digital controller detects a dewpoint temperature below -2°C / 28,4°F during more than 2 minutes, (L2 Alarms), it switches off the refrigerant compressor.

**AUTOMATIC CUT OUT OF REFRIGERANT COMPRESSOR**

If the refrigerant temperature detected at the delivery pipe of refrigerant compressor overcome the limit setted by manufacturer, the controller stops the refrigerant compressor in order to avoid further possible failure.

**RESETTING THE DRYER AFTER A REFRIGERANT COMPRESSOR STOP**

Press button 7 to reset the alarm.

The dryer restarts when both the following conditions are true.

- The dewpoint temperature is higher than -2°C / 28,4°F
  - 30 second are passed from the refrigerant compressor stop (minimum balancing pressure stop time).
- A countdown is available if the reset is made before the minimum stop time.

**SILENT ALARM FUNCTION**

To snooze the alarm, press button 5.

**REFRIGERANT COMPRESSOR DISCHARGE TEMPERATURE VISUALIZATION FUNCTION**

To see the discharge refrigerant compressor temperature, follow steps 1 to 5:

1. PDP is showing standard view.
2. Push and hold buttons SET (6) and DOWN (8) to enter the menu.
3. Push and release the UP button (7) until message “S3” appears on display.



4. Push and release the SET button (7) to enter the “S3” parameter.
5. Current temperature of discharge refrigerant compressor is displayed.





## 17.2 REMOTE START/STOP FUNCTION

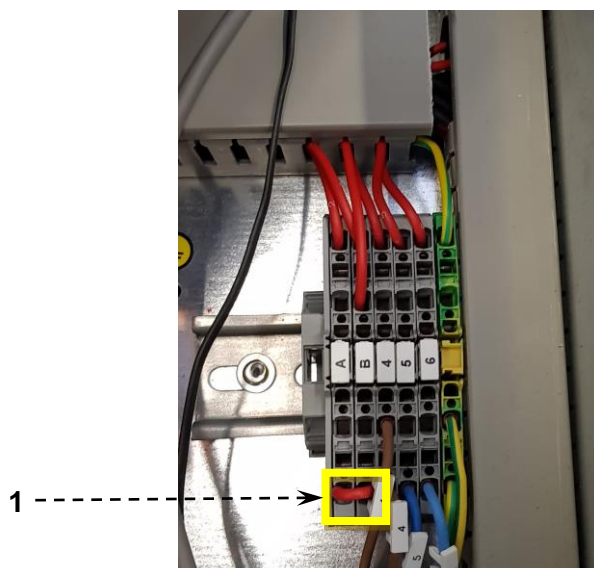

Remove the bridge between A and B and wire a potential free contact in between.  
The machine will be remotely controlled by the potential free contact, when the main switch is ON.



Tag clearly that the machine is remotely controlled !



1. check carefully the electrical diagram before to proceed with any electrical action
2. The potential free contact **MUST** be tight. A false contact can damage the electrical components
3. Switch off the machine (main switch OFF ) before opening the cubicle door
4. Every damage coming from an incorrect or missing application of the following prescriptions, cannot be addressed to the manufacturer and can affect the warranty of the products

## 18.0 STARTING UP



**BEFORE CARRYING OUT ANY OPERATION ON THE MACHINE, ENSURE THAT THE ELECTRIC POWER SUPPLY HAS BEEN DISCONNECTED  
WAIT AT LEAST TWO HOURS BEFORE STARTING UP, AFTER ANY MACHINE MOVEMENT (TRANSPORT OR HANDLING).**

### 18.1 PRELIMINARY CONTROLS

Before starting the dryer, check:

- The correct connection to the compressed air piping: remember to remove eventual caps on the drier inlet and outlet.
- The correct connection to the condensate drainage system.
- That the power supply is right.

### 18.2 STARTING AND STOP

Start the system before the air compressor starts running and stop it after the air compressor has been stopped. The compressed air piping will be free of condensate only by doing so. The drier must be kept running during all the time the air compressor is running.

**WARNING:** if the drier is switched off, before starting it again, wait at least 5 minutes in order to allow the pressure balancing.

**BEFORE CARRYING OUT ANY MAINTENANCE JOBS IT IS OBLIGATORY TO STOP THE MACHINE AND DISCONNECT IT FROM THE POWER MAINS AND FROM THE COMPRESSED AIR DISTRIBUTION NETWORK.**

**PRESSURE DISCHARGE PROCEDURE**

Proceed as follows:

- Close the taps Ref. 1 Fig. 11
- Release the pressure in the dryer by pressing the condensate drain "TEST" pushbutton locate on the steam trap Ref. 1 Fig. 11
- Switch off the machine. Turn the switch in position STOP Ref. 3 Fig. 11
- Turn on the supply automatic differential switch Ref. 4 Fig. 11

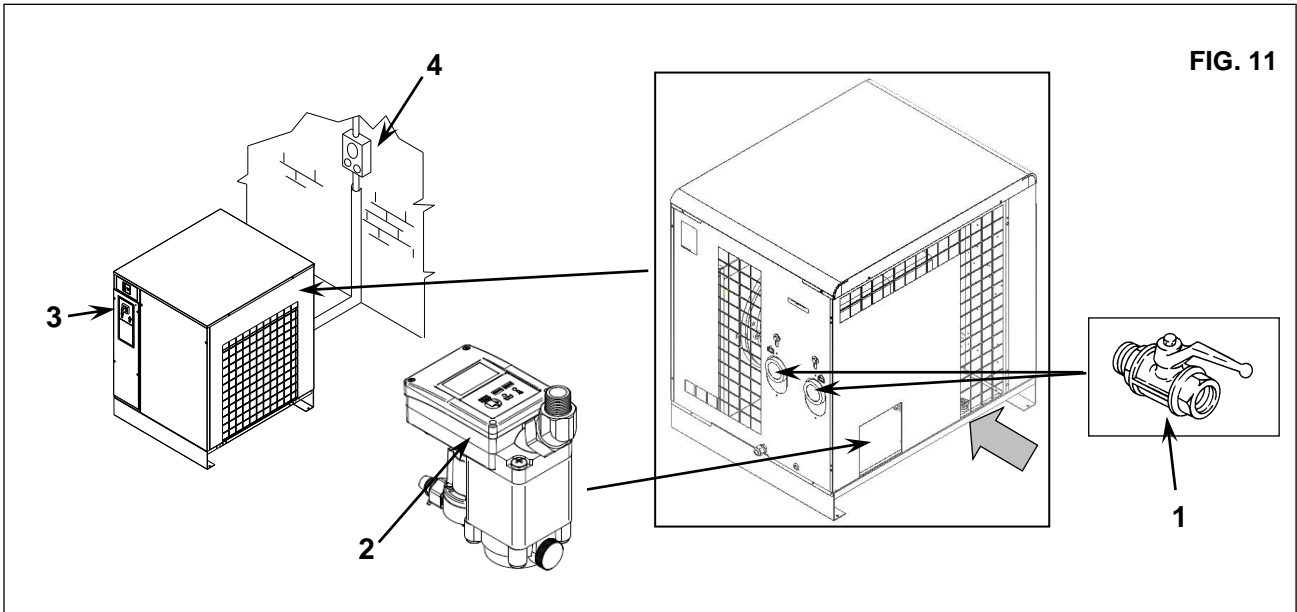

**CALIBRATIONS  
BYPASS VALVE FOR HOT GAS**

N.B. These valves have already been calibrated and they do not require any adjustment. A dew point different from the rated one generally depends on causes which are not attributable to their operation.

- Ref. 1) Closing cap
- Ref. 2) Adjusting screw

**WORKING PRESSURES AND TEMPERATURES OF R410A**

	SUCTION SIDE OF REFRIGERATION COMPRESSOR	
	Evaporat. Temperat. °C (°F)	Evaporating Pressure bar (psi)
RATED VALUES AT AMBIENT (Temperat. 20°C - 68°F)	0 ÷ 1 32 ÷ 33,8	<b>R410A</b> 7,0 ÷ 7,2 101,5 ÷ 104,4

