

Service Instructions

A/GPH 16 SEER PACKAGE HEAT PUMPS MULTI-POSITION MODELS WITH R-410A REFRIGERANT

Model numbers on page 6.

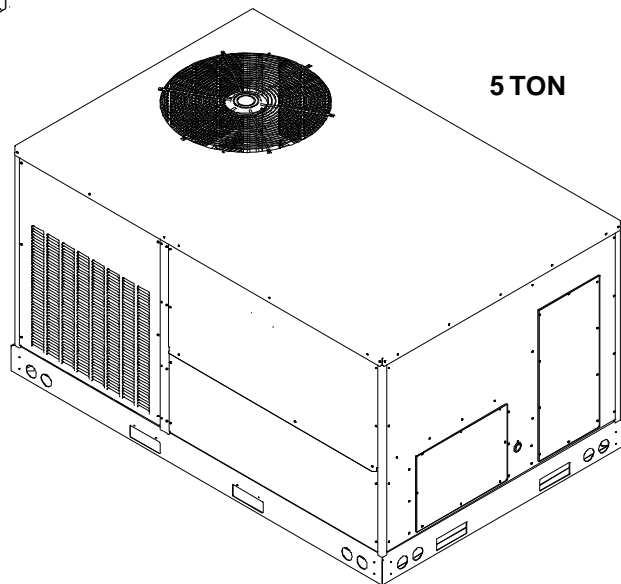
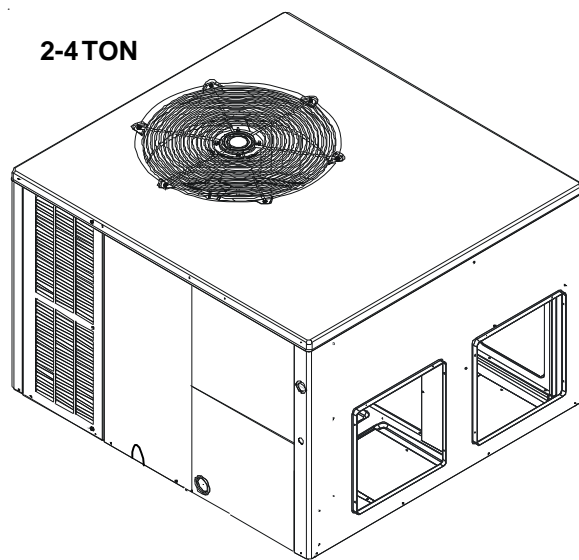

This manual is to be used by qualified, professionally trained HVAC technicians only. Goodman does not assume any responsibility for property damage or personal injury due to improper service procedures or services performed by an unqualified person.

RS6334001r3
October 2016

INDEX

IMPORTANT INFORMATION	4-5
PRODUCT IDENTIFICATION	6
ACCESSORIES	7
GPGHFR101-103	8
GPH13MFR FILTER RACK	8
PGMDD101-103 DOWNFLOW MANUAL FRESH AIR DAMPERS	9
PGMDMD102-103 DOWNFLOW MOTORIZED FRESH AIR DAMPERS	9
PGMDH102-103 HORIZONTAL MANUAL FRESH AIR DAMPERS	9
PGMDH102-103 HORIZONTAL MOTORIZED FRESH AIR DAMPERS	9
SQRPG101-103 SQUARE TO ROUND CONVERTER, DOWNFLOW	10
SQRPGH101-103 SQUARE TO ROUND CONVERTER, HORIZONTAL	10
GPH13MED103 DOWNFLOW ECONOMIZER	11
DHZECNJPCH[M/L] HORIZONTAL ECONOMIZER	12
PGC101-103 ROOF CURBS	12
PRODUCT DESIGN	16
LOCATION AND CLEARANCES	16
COMPRESSOR	17
INDOOR BLOWER MOTOR	17
ELECTRICAL WIRING	18
LINE VOLTAGE WIRING	18
SYSTEM OPERATION	19
A/GPH16 COOLING	19
COOLING CYCLE	19
HEATING CYCLE	19
DEFROST CYCLE	19
FAN OPERATION	20
SCHEDULED MAINTENANCE	22
ONCE A MONTH	22
ONCE A YEAR	22
TEST EQUIPMENT	22
SERVICING	23
COOLING /HEAT PUMP- SERVICE ANALYSIS GUIDE	23
S-1 CHECKING VOLTAGE	24
S-2 CHECKING WIRING	25
S-3 CHECKING THERMOSTAT, WIRING, AND ANTICIPATOR	25
S-3A Thermostat and Wiring	25
S-3B Cooling Anticipator	25
S-3C Heating Anticipator	25
S-4 CHECKING TRANSFORMER AND CONTROL CIRCUIT	26
S-7 CHECKING CONTACTOR AND/OR RELAYS	26
S-8 CHECKING CONTACTOR CONTACTS	26
S-11 CHECKING LOSS OF CHARGE PROTECTOR	27
S-12 CHECKING HIGH PRESSURE CONTROL.....	27
S-15 CHECKING CAPACITOR	27
S-15A Resistance Check	28
S-15B Capacitance Check	28
S-16 CHECKING MOTORS	29

INDEX

S-16A Checking Fan and Blower Motor Windings (PSC Motors)	29
S-16C Checking ECM Motor Windings	29
S-16D Checking EEM Motors	29
S-17C UNLOADER TEST PROCEDURE.....	30
S-17 CHECKING COMPRESSOR WINDINGS	30
S-17A Resistance Test	31
S-17B Ground Test	31
S-17D Operation Test	32
S-18 TESTING CRANKCASE HEATER	32
S-18A TESTING CRANKCASE HEATER THERMOSTAT	32
S-21 CHECKING REVERSING VALVE AND SOLENOID	32
S-24 TESTING DEFROST CONTROL	33
S-25 TESTING DEFROST THERMOSTAT	33
S-50 CHECKING HEATER LIMIT CONTROL(S)	33
S-52 CHECKING HEATER ELEMENTS	33
S-100 REFRIGERATION REPAIR PRACTICE	33
S-101 LEAK TESTING (NITROGEN OR NITROGEN-TRACED)	34
S-102 EVACUATION	34
S-103 CHARGING	35
S-104 CHECKING COMPRESSOR EFFICIENCY	36
S-105 THERMOSTATIC EXPANSION VALVE	36
S-106 OVERFEEDING	36
S-107 UNDERFEEDING	36
S-108 SUPERHEAT	36
S-109 CHECKING SUBCOOLING	36
S-110 CHECKING EXPANSION VALVE OPERATION	37
S-112 CHECKING RESTRICTED LIQUID LINE	41
S-113 REFRIGERANT OVERCHARGE	41
S-114 NON-CONDENSABLES	41
S-115 COMPRESSOR BURNOUT	41
S-122 REVERSING VALVE REPLACEMENT	42
S-200 CHECKING EXTERNAL STATIC PRESSURE	42
S-201 CHECKING TEMPERATURE RISE	43
AIR FLOW DATA	44
WIRING DIAGRAMS	48
OT18-60A OUTDOOR THERMOSTAT	48
OT18-60A OUTDOOR THERMOSTAT	49
HKP** / HKR** HEAT KITS - SINGLE PHASE	50
HKR** HEAT KITS - THREE PHASE	52
EHK1 - 10 HEAT KIT - 10KW.....	53
EHK1 - 15 HEAT KIT - 15KW.....	54
EHK1 - 20 HEAT KIT - 20KW.....	55
EHK3 - 10KW,EHK3-15 HEAT KITS - 15KW.....	56
EHK3 - 20 HEAT KIT - 20KW.....	57
GPJMED & DHZECNJPJGCH ECONOMIZER FOR A/GPH16**M4*	58
APH16[24-48]M41A*	59
GPH16[24-48]M41A*	61

IMPORTANT INFORMATION

Pride and workmanship go into every product to provide our customers with quality products. It is possible, however, that during its lifetime a product may require service. Products should be serviced only by a qualified service technician who is familiar with the safety procedures required in the repair and who is equipped with the proper tools, parts, testing instruments and the appropriate service manual. **REVIEW ALL SERVICE INFORMATION IN THE APPROPRIATE SERVICE MANUAL BEFORE BEGINNING REPAIRS.**

IMPORTANT NOTICES FOR CONSUMERS AND SERVICERS RECOGNIZE SAFETY SYMBOLS, WORDS AND LABELS

WARNING

THIS UNIT SHOULD NOT BE CONNECTED TO, OR USED IN CONJUNCTION WITH, ANY DEVICES THAT ARE NOT DESIGN CERTIFIED FOR USE WITH THIS UNIT OR HAVE NOT BEEN TESTED AND APPROVED BY THE MANUFACTURER. SERIOUS PROPERTY DAMAGE OR PERSONAL INJURY, REDUCED UNIT PERFORMANCE AND/OR HAZARDOUS CONDITIONS MAY RESULT FROM THE USE OF DEVICES THAT HAVE NOT BEEN APPROVED OR CERTIFIED BY THE MANUFACTURER.

WARNING

ONLY PERSONNEL THAT HAVE BEEN TRAINED TO INSTALL, ADJUST, SERVICE OR REPAIR (HEREINAFTER, "SERVICE") THE EQUIPMENT SPECIFIED IN THIS MANUAL SHOULD SERVICE THE EQUIPMENT. THE MANUFACTURER WILL NOT BE RESPONSIBLE FOR ANY INJURY OR PROPERTY DAMAGE ARISING FROM IMPROPER SERVICE OR SERVICE PROCEDURES. IF YOU SERVICE THIS UNIT, YOU ASSUME RESPONSIBILITY FOR ANY INJURY OR PROPERTY DAMAGE WHICH MAY RESULT. IN ADDITION, IN JURISDICTIONS THAT REQUIRE ONE OR MORE LICENSES TO SERVICE THE EQUIPMENT SPECIFIED IN THIS MANUAL, ONLY LICENSED PERSONNEL SHOULD SERVICE THE EQUIPMENT. IMPROPER INSTALLATION, ADJUSTMENT, SERVICING OR REPAIR OF THE EQUIPMENT SPECIFIED IN THIS MANUAL, OR ATTEMPTING TO INSTALL, ADJUST, SERVICE OR REPAIR THE EQUIPMENT SPECIFIED IN THIS MANUAL WITHOUT PROPER TRAINING MAY RESULT IN PRODUCT DAMAGE, PROPERTY DAMAGE, PERSONAL INJURY OR DEATH.

WARNING

TO PREVENT THE RISK OF PROPERTY DAMAGE, PERSONAL INJURY, OR DEATH, DO NOT STORE COMBUSTIBLE MATERIALS OR USE GASOLINE OR OTHER FLAMMABLE LIQUIDS OR VAPORS IN THE VICINITY OF THIS APPLIANCE.

WARNING

HIGH VOLTAGE
DISCONNECT ALL POWER BEFORE SERVICING OR INSTALLING THIS UNIT. MULTIPLE POWER SOURCES MAY BE PRESENT.
FAILURE TO DO SO MAY CAUSE PROPERTY DAMAGE, PERSONAL INJURY OR DEATH.



To locate an authorized servicer, please consult your telephone book or the dealer from whom you purchased this product. For further assistance, please contact:

GOODMAN® BRAND PRODUCTS TOLL FREE

1-877-254-4729 (U.S. only)

email us at: customerservice@goodmanmfg.com

fax us at: (713) 856-1821

(Not a technical assistance line for dealers.)

AMANA® BRAND PRODUCTS TOLL FREE

1-877-254-4729 (U.S. only)

email us at: customerservice@goodmanmfg.com

fax us at: (713) 856-1821

(Not a technical assistance line for dealers.)

Outside the U.S., call 1-713-861-2500.

(Not a technical assistance line for dealers.) Your telephone company will bill you for the call.

Amana is a registered trademark of Maytag Corporation or its related entities and is used under license. All rights reserved.

IMPORTANT INFORMATION

SAFE REFRIGERANT HANDLING

While these items will not cover every conceivable situation, they should serve as a useful guide.

WARNING

REFRIGERANTS ARE HEAVIER THAN AIR. THEY CAN "PUSH OUT" THE OXYGEN IN YOUR LUNGS OR IN ANY ENCLOSED SPACE. TO AVOID POSSIBLE DIFFICULTY IN BREATHING OR DEATH:

- NEVER PURGE REFRIGERANT INTO AN ENCLOSED ROOM OR SPACE. BY LAW, ALL REFRIGERANTS MUST BE RECLAIMED.
- IF AN INDOOR LEAK IS SUSPECTED, THOROUGHLY VENTILATE THE AREA BEFORE BEGINNING WORK.
- LIQUID REFRIGERANT CAN BE VERY COLD. TO AVOID POSSIBLE FROST-BITE OR BLINDNESS, AVOID CONTACT WITH REFRIGERANT AND WEAR GLOVES AND GOGGLES. IF LIQUID REFRIGERANT DOES CONTACT YOUR SKIN OR EYES, SEEK MEDICAL HELP IMMEDIATELY.
- ALWAYS FOLLOW EPA REGULATIONS. NEVER BURN REFRIGERANT, AS POISONOUS GAS WILL BE PRODUCED.

WARNING

THE UNITED STATES ENVIRONMENTAL PROTECTION AGENCY ("EPA") HAS ISSUED VARIOUS REGULATIONS REGARDING THE INTRODUCTION AND DISPOSAL OF REFRIGERANTS INTRODUCED INTO THIS UNIT. FAILURE TO FOLLOW THESE REGULATIONS MAY HARM THE ENVIRONMENT AND CAN LEAD TO THE IMPOSITION OF SUBSTANTIAL FINES. THESE REGULATIONS MAY VARY BY JURISDICTION. A CERTIFIED TECHNICIAN MUST PERFORM THE INSTALLATION AND SERVICE OF THIS PRODUCT. SHOULD QUESTIONS ARISE, CONTACT YOUR LOCAL EPA OFFICE. VIOLATIONS OF EPA REGULATIONS MAY RESULT IN FINES OR PENALTIES.

WARNING

SYSTEM CONTAMINANTS, IMPROPER SERVICE PROCEDURE AND/OR PHYSICAL ABUSE AFFECTING HERMETIC COMPRESSOR ELECTRICAL TERMINALS MAY CAUSE DANGEROUS SYSTEM VENTING.

The successful development of hermetically sealed refrigeration compressors has completely sealed the compressor's moving parts and electric motor inside a common housing, minimizing refrigerant leaks and the hazards sometimes associated with moving belts, pulleys or couplings.

Fundamental to the design of hermetic compressors is a method whereby electrical current is transmitted to the compressor motor through terminal conductors which pass through the compressor housing wall. These terminals are sealed in a dielectric material which insulates them from the housing and maintains the pressure tight integrity of the hermetic compressor. The terminals and their dielectric embedment are strongly constructed, but are vulnerable to careless compressor installation or maintenance procedures and equally vulnerable to internal electrical short circuits caused by excessive system contaminants.

WARNING

TO AVOID POSSIBLE EXPLOSION:

- NEVER APPLY FLAME OR STEAM TO A REFRIGERANT CYLINDER. IF YOU MUST HEAT A CYLINDER FOR FASTER CHARGING, PARTIALLY IMMERSE IT IN WARM WATER.
- NEVER FILL A CYLINDER MORE THAN 80% FULL OF LIQUID REFRIGERANT.
- NEVER ADD ANYTHING OTHER THAN R-22 TO AN R-22 CYLINDER OR R-410A TO AN R-410A CYLINDER. THE SERVICE EQUIPMENT USED MUST BE LISTED OR CERTIFIED FOR THE TYPE OF REFRIGERANT USED.
- STORE CYLINDERS IN A COOL, DRY PLACE. NEVER USE A CYLINDER AS A PLATFORM OR A ROLLER.

WARNING

TO AVOID POSSIBLE EXPLOSION, USE ONLY RETURNABLE (NOT DISPOSABLE) SERVICE CYLINDERS WHEN REMOVING REFRIGERANT FROM A SYSTEM.

- ENSURE THE CYLINDER IS FREE OF DAMAGE WHICH COULD LEAD TO A LEAK OR EXPLOSION.
- ENSURE THE HYDROSTATIC TEST DATE DOES NOT EXCEED 5 YEARS.
- ENSURE THE PRESSURE RATING MEETS OR EXCEEDS 400 LBS.

WHEN IN DOUBT, DO NOT USE CYLINDER.

WARNING

TO AVOID POSSIBLE INJURY, EXPLOSION OR DEATH, PRACTICE SAFE HANDLING OF REFRIGERANTS.

In either of these instances, an electrical short between the terminal and the compressor housing may result in the loss of integrity between the terminal and its dielectric embedment. This loss may cause the terminals to be expelled, thereby venting the vaporous and liquid contents of the compressor housing and system.

A venting compressor terminal normally presents no danger to anyone, providing the terminal protective cover is properly in place.

If, however, the terminal protective cover is not properly in place, a venting terminal may discharge a combination of

- (a) hot lubricating oil and refrigerant
- (b) flammable mixture (if system is contaminated with air)

in a stream of spray which may be dangerous to anyone in the vicinity. Death or serious bodily injury could occur.

Under no circumstances is a hermetic compressor to be electrically energized and/or operated without having the terminal protective cover properly in place.

See Service Section S-17 for proper servicing.

PRODUCT IDENTIFICATION

The model number is used for positive identification of component parts used in manufacturing. Please use this number when requesting service or parts information.

Single Phase Multiposition Heat Pump	
Model #	Description
APH16[24-48]M41AA	A mana® Brand P ackage H eat Pump up to 16 SEER R410A Multiposition heating/cooling units. Initial release of single phase models.
GPH16[24-48]M41AA	G oodman® Brand P ackage H eat Pump up to 16 Seer R410A Multiposition heating/cooling units. Initial release of single phase models.
APH16[24-48]M41AB	A mana® Brand P ackage H eat Pump up to 16 SEER R410A Multiposition heating/cooling units. Release of models with access box removed.
GPH16[24-48]M41AB	G oodman® Brand P ackage H eat Pump up to 16 Seer R410A Multiposition heating/cooling units. Release of models with access box removed.
APH1660M41AA	A mana® Brand Package Heat Pump up to 16 SEER R410A Multiposition heating/cooling units. Converting light commercial 6 ton unit to 5 ton residential gas pack and heat pump units.
GPH1660M41AA	G oodman® Brand P ackage H eat Pump up to 16 Seer R410A Multiposition heating/cooling units. Converting light commercial 6 ton unit to 5 ton residential gas pack and heat pump units.

ACCESSORIES

A/GPH16[24-48]M41*

ACCESSORIES - A/GPH16**M MODELS	
Part Number	Description
OT18-60A	Outdoor Thermostat Kit w/Lockout Stat
OT/EHR18-60	Emergency Heat Relay Kit
HKP[05,10,15,20]; HKR08	Single Phase 208-230 Volt Electric Heat Kit
HKR3	Three Phase 208-230 Volt Electric Heat Kit
PGC101/102/103	Roof Curb
DHZECNJP GCHM	Goodman/Daikin Horizontal Jade Economizer M Series Package Unit All Fuels, Medium Chassis, H Series All Fuels, All Chassis
DHZECNJP GCHL	Goodman/Daikin Horizontal Jade Economizer M Series Package Unit. All Fuels, Large Chassis
PGMDD101/102	Manual 25% Fresh Air Damper Downflow Application, Small and Medium Chassis
PGMDD103	Manual 25% Fresh Air Damper Downflow Application, Large Chassis
PGMDH102	Manual 25% Fresh Air Damper Horizontal Application, Medium Chassis
PGMDH103	Manual 25% Fresh Air Damper Horizontal Application, Large Chassis
PGMDMD101/102	Motorized 25% Fresh Air Damper Downflow Application, Small and Medium Chassis
PGMDMD103	Motorized 25% Fresh Air Downflow Application, Large Chassis
PGMDMH102	Motorized 25% Fresh Air Damper Horizontal Application, Medium Chassis
PGMDMH103	Motorized 25% Fresh Air Damper Horizontal Application, Large Chassis
GPJMED102	Goodman Downflow Jade Economizer for M Series Package A/C and Heat Pump, Medium Chassis
GPJMED103	Goodman Downflow Jade Economizer for M Series Package A/C and Heat Pump, Large Chassis
GPH13MFR102	Internal Filter Rack, Medium Chassis
GPH13MFR103	Internal Filter Rack, Large Chassis
GPGHFR101-103	External Horizontal Filter Rack for Goodman/Amana Gas/Electric and Multi-position Package Units All Chassis
SQRPG101/102	Square to Round Adapter w/ 16" Round Downflow Application, Medium Chassis
SQRPG103	Square to Round Adapter w/ 18" Round Downflow Application, Large Chassis
SQRPGH101/102	Square to Round Adapter w/ 16" Round Horizontal Application, Medium Chassis
SQRPGH103	Square to Round Adapter w/ 18" Round Horizontal Application, Large Chassis
CDK36	Flush Mount Concentric Duct Kit
CDK36515	Flush Mount Concentric Duct Kit w/ Filter
CDK36530	Step Down Concentric Duct Kit
CDK36535	Step Down Concentric Duct Kit w/ Filter
CDK4872	Flush Mount Concentric Duct Kit
CDK4872515	Flush Mount Concentric Duct Kit w/ Filter
CDK4872530	Step Down Concentric Duct Kit
CDK4872534	Step Down Concentric Duct Kit w/ Filter
SPK15-60	Single Point Wiring Kits

NOTE: Complete lineup of thermostats can be found in the Thermostat Specification Sheets.

ACCESSORIES

A/GPH/16[24-48]M41*

EXTERNAL HORIZONTAL FILTER RACK (GPGHFR101-103)

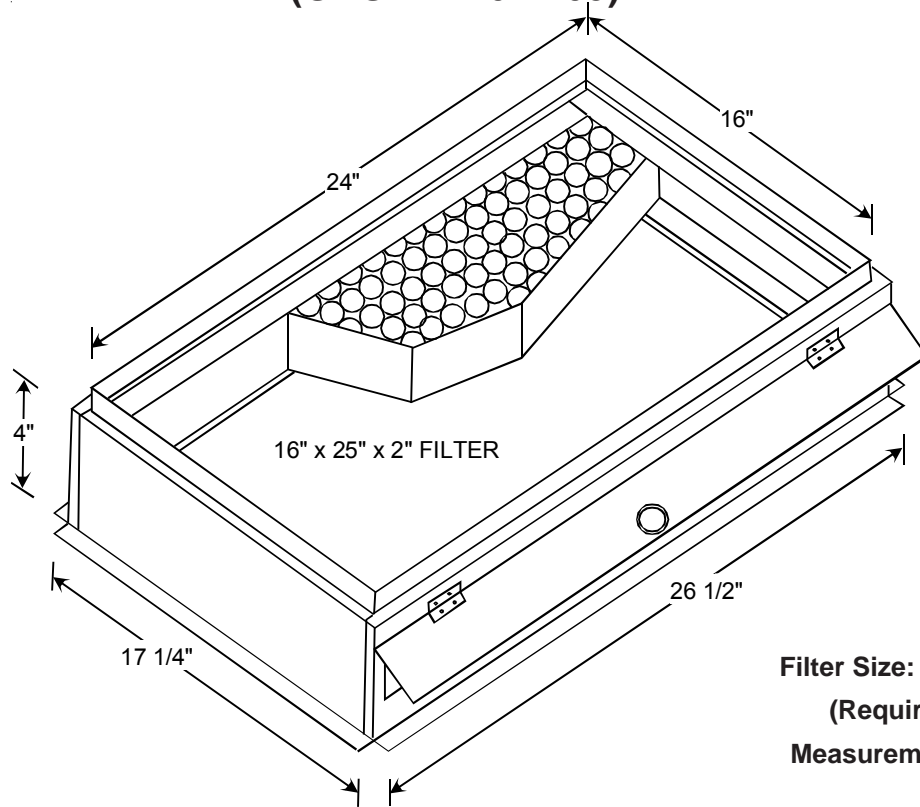

DOWNFLOW FILTER RACK (GPH13MFR)

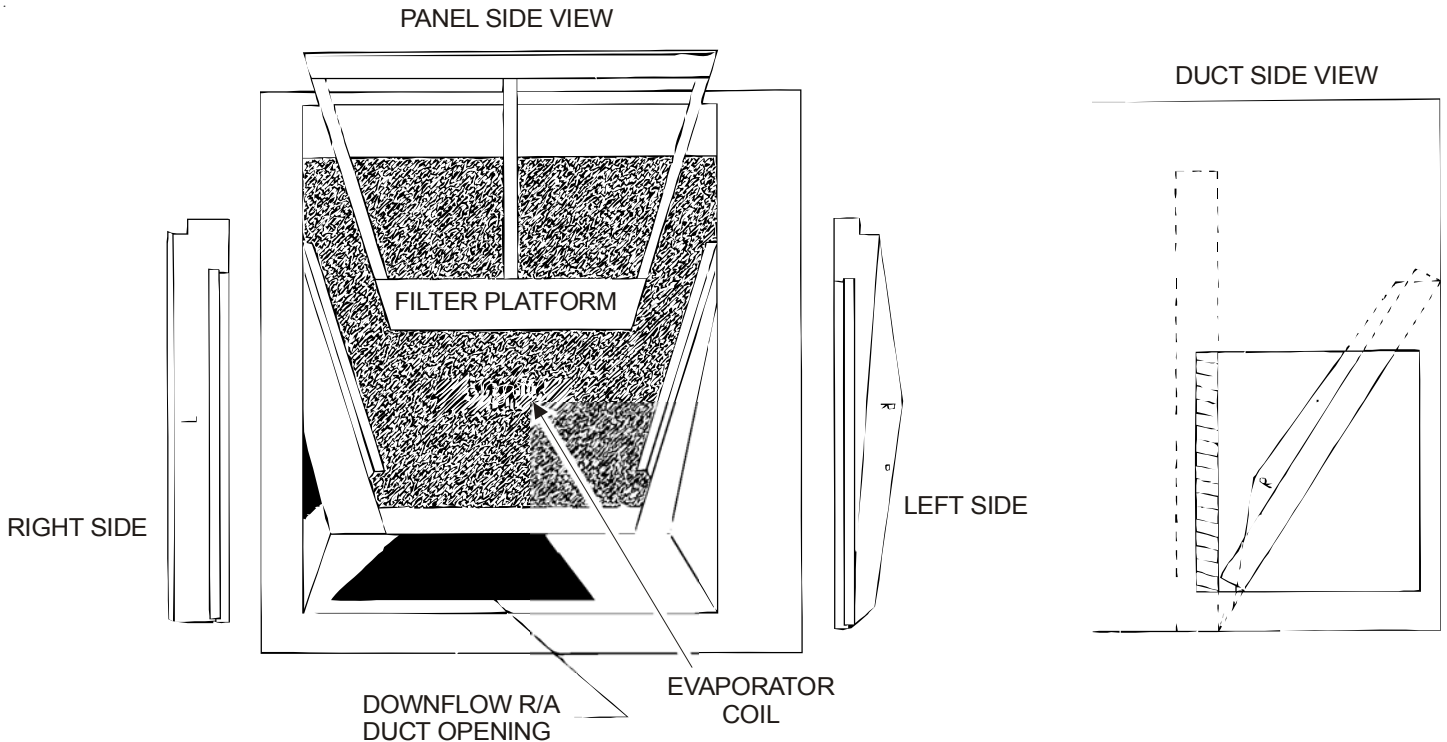

Filter Size: 14" x 25" x 2" (Requires 2 filters) - Measurement in inches

ACCESSORIES

A/GPH16[24-48]M41*

MOTORIZED/MANUAL FRESH AIR DAMPERS - (HORIZONTAL APPLICATIONS)

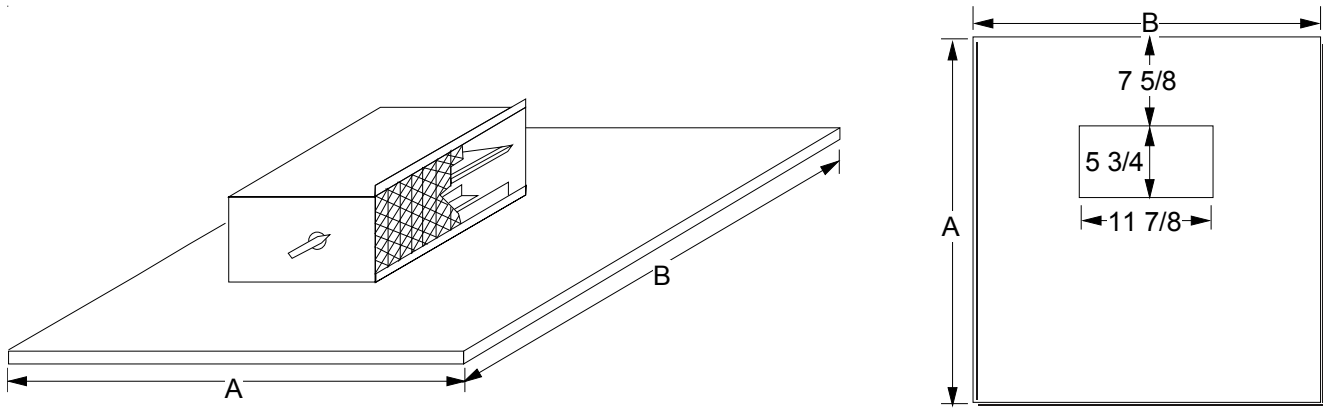

Manual Fresh Air Dampers

MODEL	A	B
PGMDH102	31 1/2	29 3/4
PGMDH103	39	29 3/4

Motorized Fresh Air Dampers

MODEL	A	B
PGMDMH102	31 1/2	29 3/4
PGMDMH103	39	29 3/4

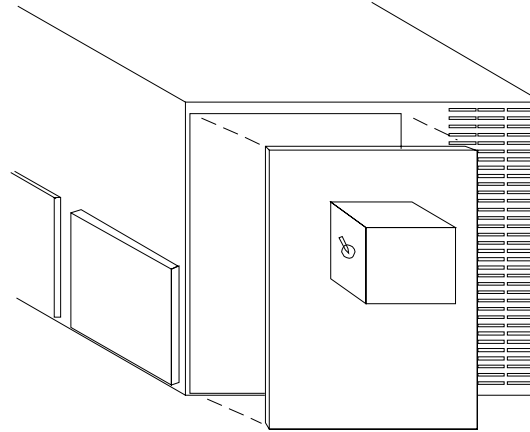

MOTORIZED/MANUAL FRESH AIR DAMPERS (DOWNFLOW APPLICATIONS)

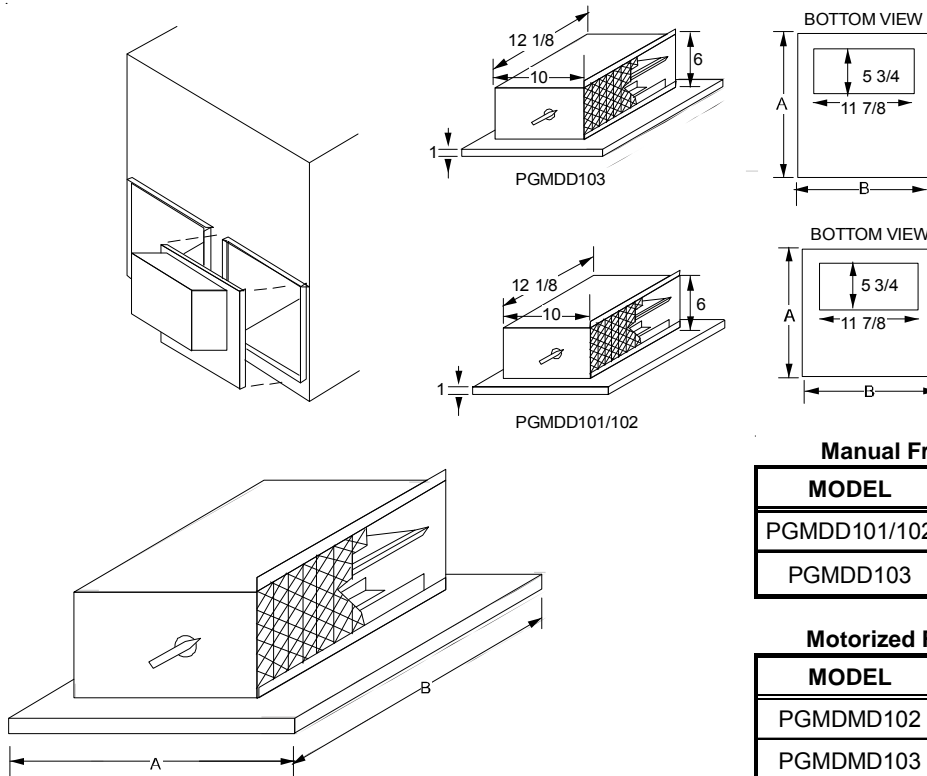

Manual Fresh Air Dampers

MODEL	A	B
PGMDD101/102	16	16
PGMDD103	18	16

Motorized Fresh Air Dampers

MODEL	A	B
PGMDMD102	16	16
PGMDMD103	18	16

**SQUARE TO ROUND CONVERTER
(DOWNFLOW APPLICATIONS)**

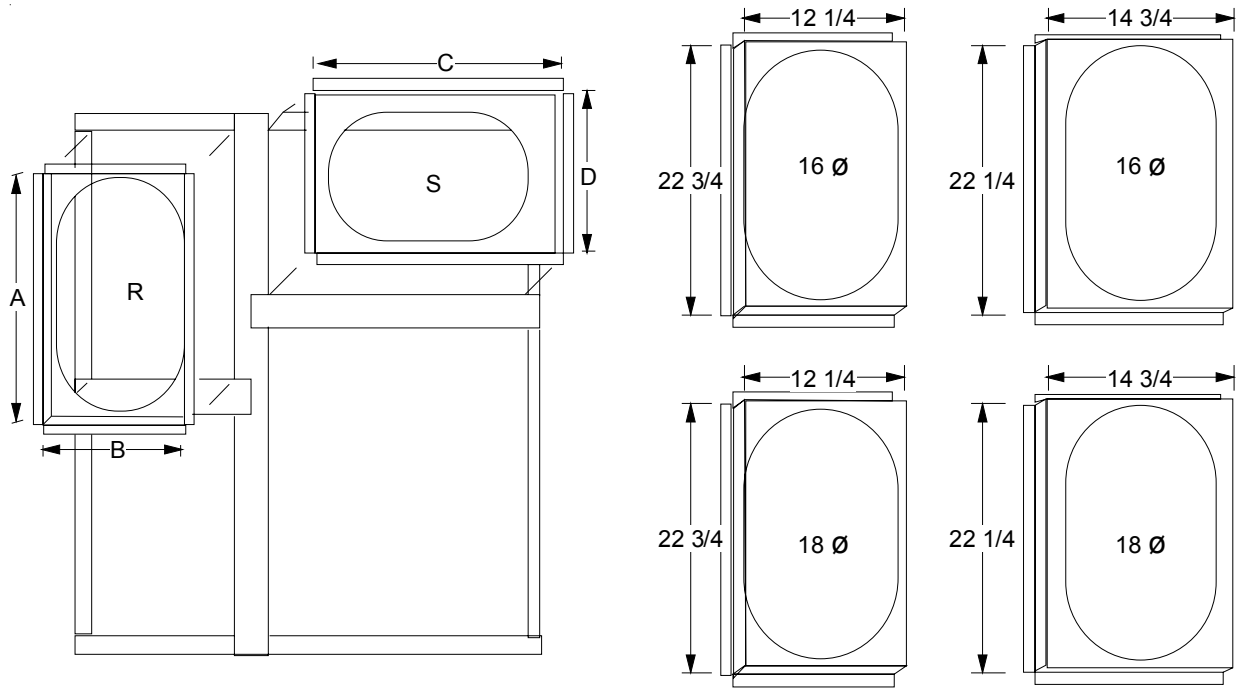

MODEL	A	B	C	D	RETURN	SUPPLY
SQRPG101/102	22 3/4	12 1/4	22 1/4	14 3/4	16	16
SQRPG103	22 3/4	12 1/4	22 1/4	14 3/4	18	18

**SQUARE TO ROUND CONVERTER
(HORIZONTAL APPLICATIONS)**

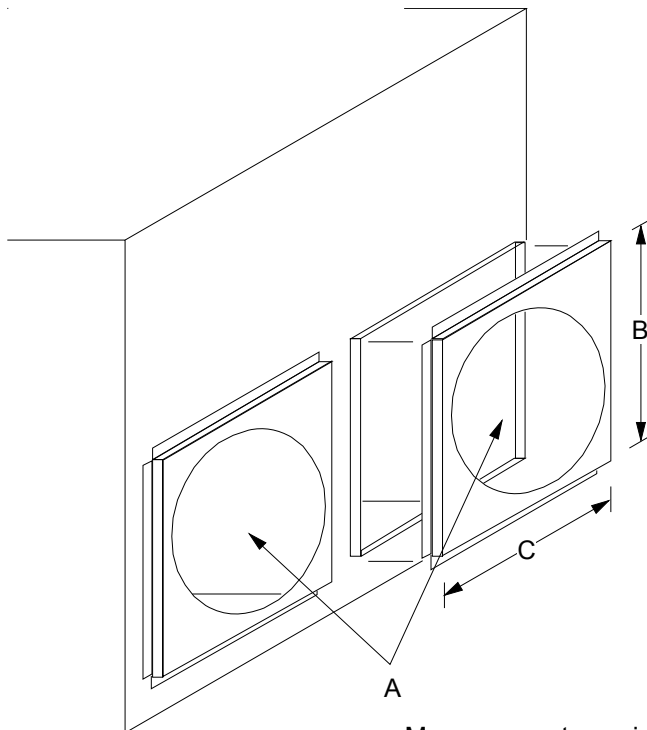

MODEL	A	B	C
SQRPGH101/102	16	16 1/2	16 1/2
SQRPGH103	18	18 1/2	18 1/2

Measurements are in inches.

**ECONOMIZER GPJMED102
(DOWNFLOW APPLICATIONS)**

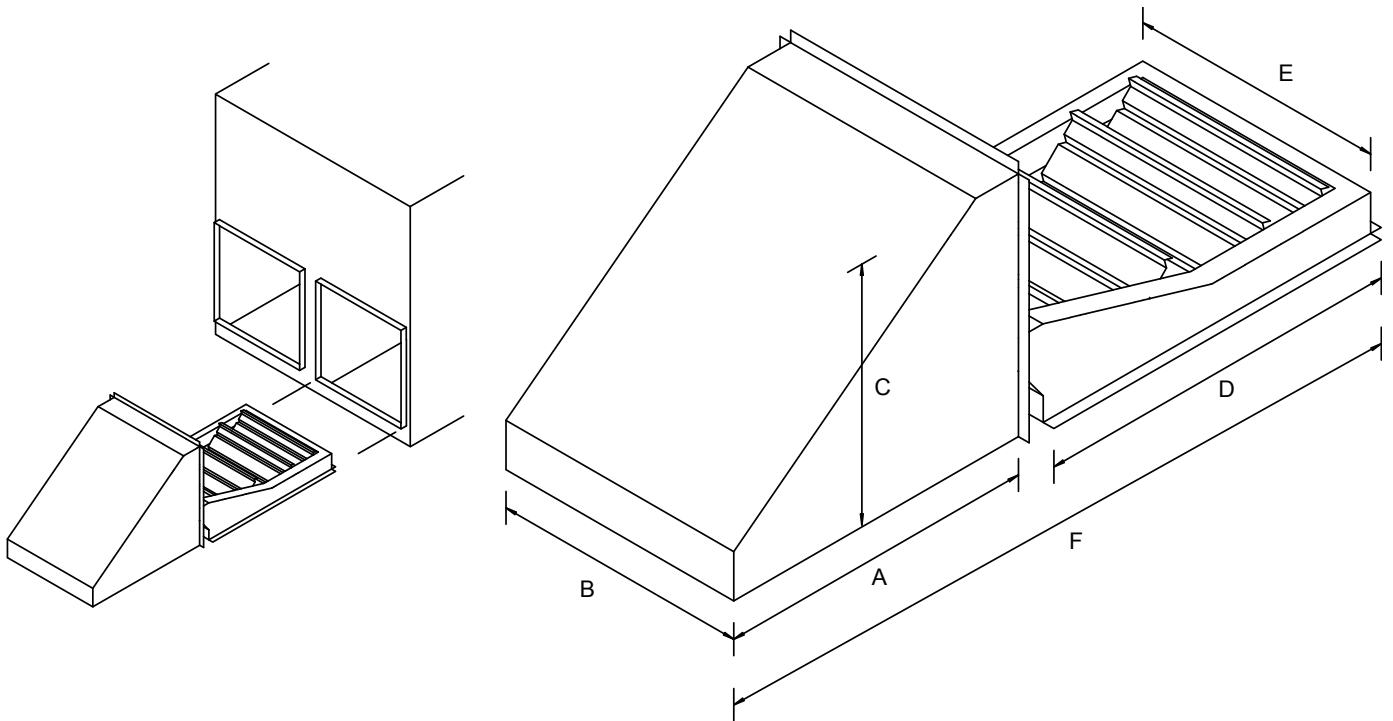

	A	B	C	D	E	F
PGED101/102	20	16.25	16	23.5	12.5	45.75

**ECONOMIZER GPJMED103
(DOWNFLOW APPLICATIONS)**

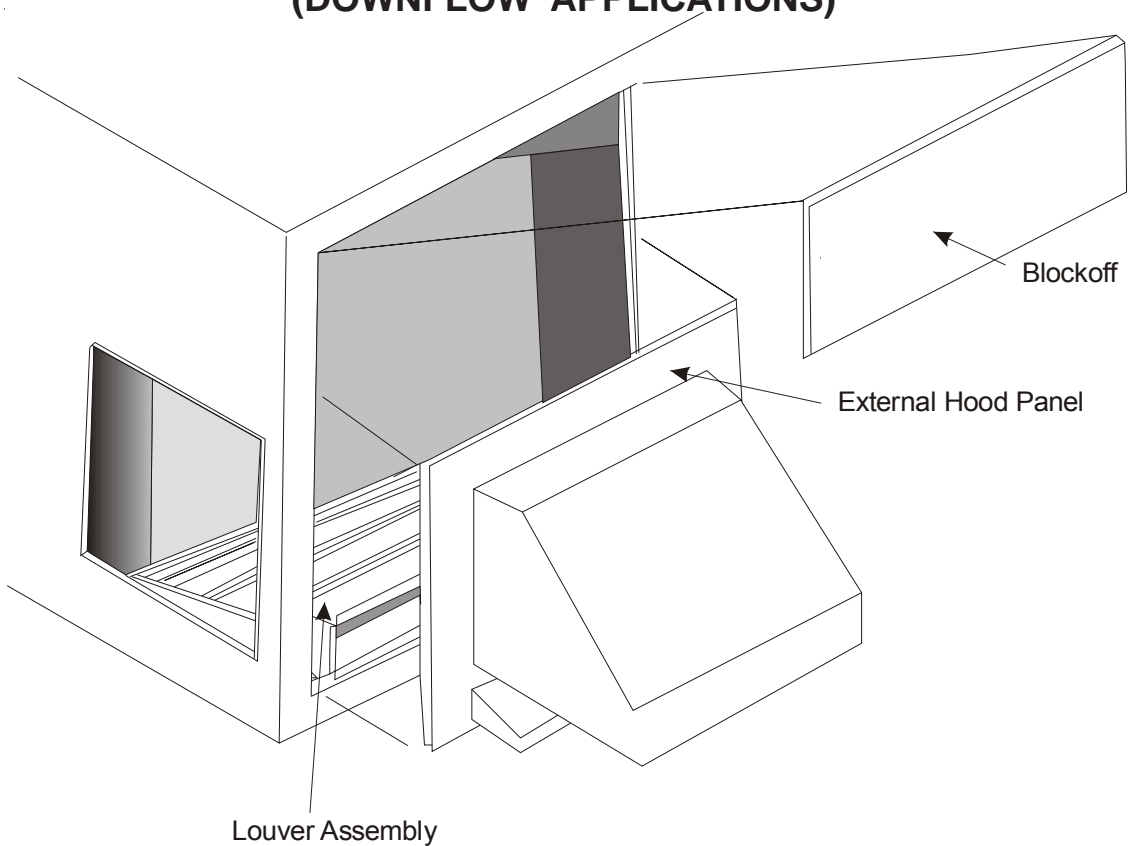

ECONOMIZER DHZECNJP GCH[M/L]
(HORIZONTAL APPLICATIONS)

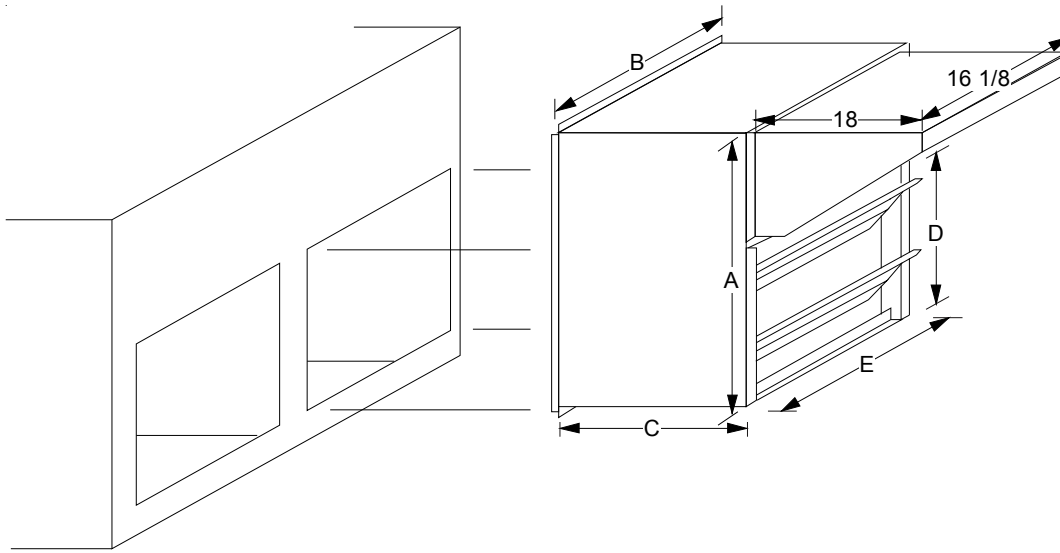

MODEL	A	B	C	D	E	FILTER
DHZECNJP GCHM	25 1/4	18 18	18	13 3/4	16 1/8	16 X 25 X1
DHZECNJP GCHL	35 1/4	18 1/8	18	18 1/4	16 1/8	16 X 25 X1

Measurements in inches

ROOF CURBS

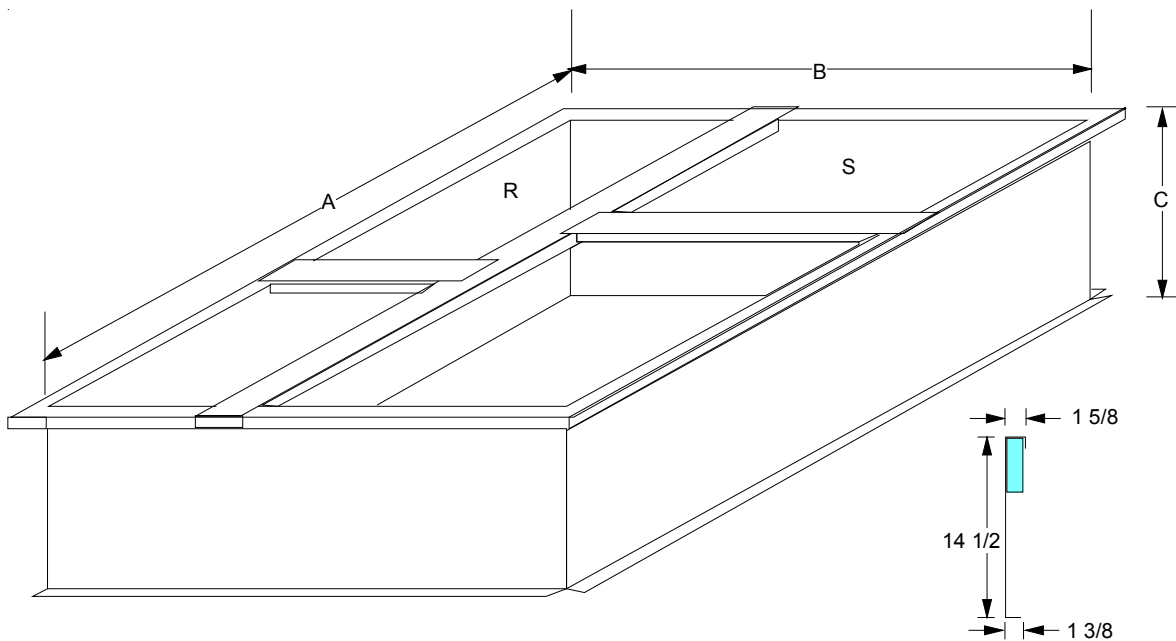

MODEL	A	B	C	RETURN	SUPPLY
PGC101/102/103	46 1/4*	39 3/8*	14 1/2	12 1/2 x 23*	15 x 22 1/2*

*Inside Dimensions

ACCESSORIES

HEAT PUMP A/GPH1660M41

Part Number	Description
14CURB3672	14" Roof Curb
D25FD3672	25% Manual Fresh Air Damper
D25MFD3672	25% Motorized Fresh Air Damper
CDK4872	Concentric Duct Kit
DDNECNJ3672B	Low-Leak Downflow Economizer
DDNECNJ3672NR	Downflow Economizer w/o Barometric Relief
DDNSQRD487218	Downflow Square to Round Adapter (18" Round)
	Electric Heat Kits
DHZECNJ3672	Horizontal Economizer
DBRD3672	Barometric Relief Damper
LAKT01	Low Ambient Kit

ACCESSORIES

ROOF CURBS 14CURB3672

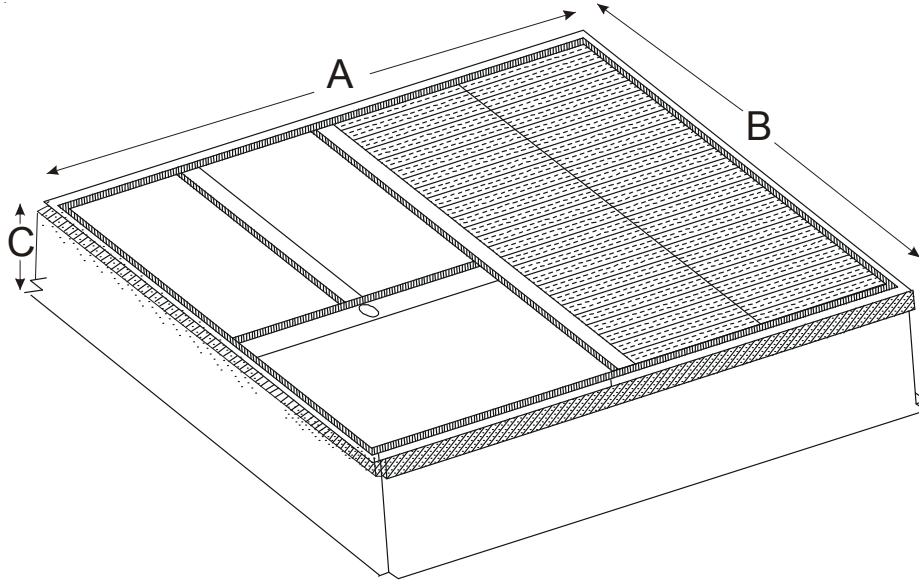

D14CURB3672				
Chassis	Model	A	B	C
#1	5 Ton	70 3/4"	37"	14"

Measurement in inches

DOWNFLOW SQUARE TO ROUND ADAPTERS DDNSQRD4872148

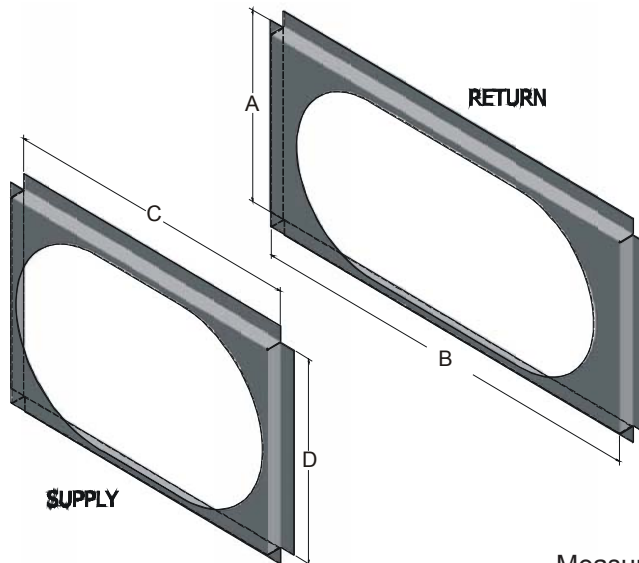

Measurement in inches

DOWNFLOW SQUARE TO ROUND ADAPTER					
MODEL	SIZE	A	B	C	D
DDNSQRD487218	18" ROUND	13.50	31.125	19.50	19.00

ACCESSORIES

MOTORIZED/MANUAL FRESH AIR DAMPERS

25% FRESH AIR DAMPER			
CHASSIS	MODEL	MANUAL	MOTORIZED
#1	5 TON	D25FD3672	D25MFD3672

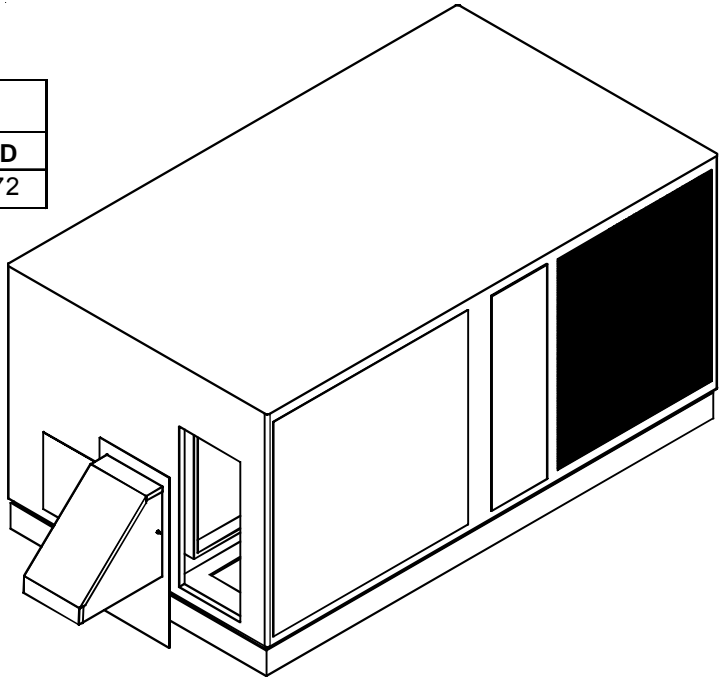

ECONOMIZERS

HORIZONTAL ECONOMIZER		
MODEL	TYPE	MODEL
DHZECNJ3672	HORIZONTAL	5 TON

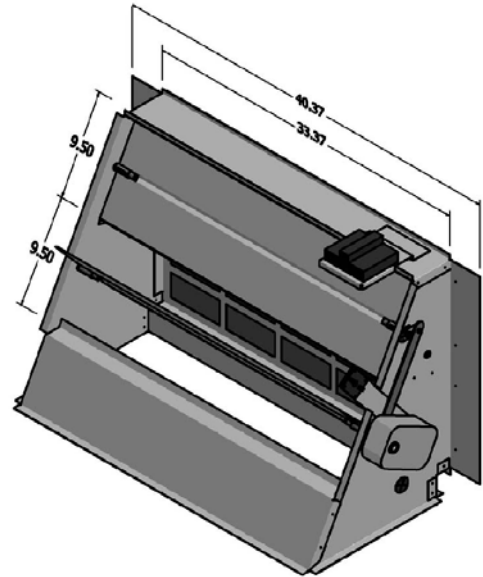
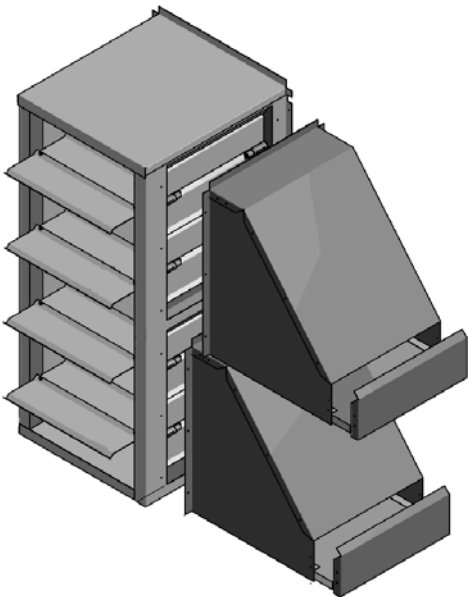

DOWNFLOW ECONOMIZER		
MODEL	TYPE	MODEL
DDNECNJ3672B	DOWNFLOW (MCDANIEL METALS)	5 TON
DDNECNJ3672NR	DOWNFLOW W/O BAROMETRIC RELIEF (MCDANIEL METALS)	5 TON

PRODUCT DESIGN

LOCATION & CLEARANCES

NOTE: To ensure proper condensate drainage, unit must be installed in a level position.

In installations where the unit is installed above ground level and not serviceable from the ground (Example: Roof Top installations) the installer must provide a service platform for the service person with rails or guards in accordance with local codes or ordinances.

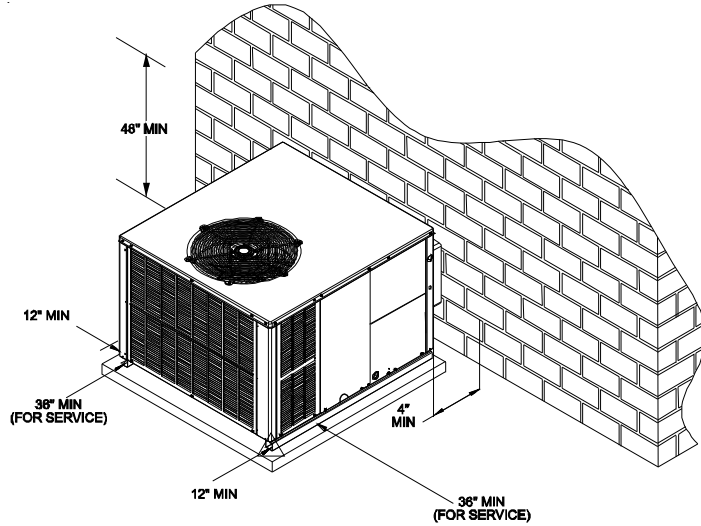

A/GPH16[24-48]M4**

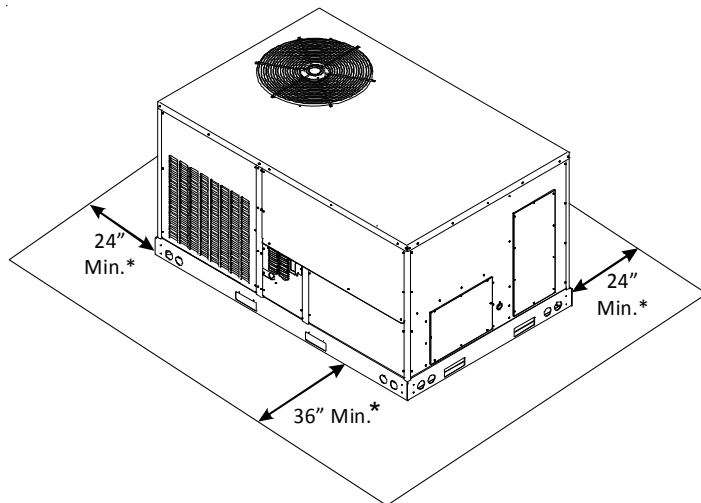

A/GPH1660M4**

Unit Clearances

**In situations that have multiple units, a 48" minimum clearance is required between the condenser coils.*

Adequate clearance around the unit should be kept for safety, service, maintenance, and proper unit operation. A total clearance of 75" on the main control panel side of the unit is recommended to facilitate possible fan shaft, coil, electric heat and gas furnace removal. A clearance of 48" is recommended on all other sides of the unit to facilitate possible compressor re-

moval, to allow service access and to insure proper ventilation and condenser airflow. The unit must not be installed beneath any obstruction. The unit should be installed remote from all building exhausts to inhibit ingestion of exhaust air into the unit fresh air intake.

PROTRUSION

Inspect curb to ensure that none of the utility services (electric) routed through the curb protrude above the curb.

NOTE: Roof overhang should be no more than 36" and provisions made to deflect the warm discharge air out from the overhang.

Minimum clearances are required to avoid air recirculation and keep the unit operating at peak efficiency.

⚠ WARNING

TO PREVENT POSSIBLE DAMAGE, THE UNIT SHOULD REMAIN IN AN UPRIGHT POSITION DURING ALL RIGGING AND MOVING OPERATIONS. TO FACILITATE LIFTING AND MOVING IF A CRANE IS USED, PLACE THE UNIT IN AN ADEQUATE CABLE SLIDE.

Refer to Roof curb Installation Instructions for proper curb installation. Curbing must be installed in compliance with the National Roofing Contractors Association Manual.

Lower unit carefully onto roof mounting curb. While rigging unit, center of gravity will cause condenser end to be lower than supply air end.

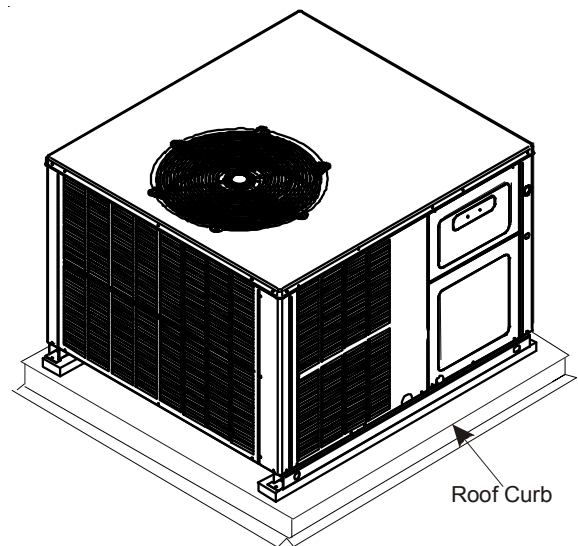

A/GPH16[24-48]M4**

A/GPH Package Units are designed for outdoor installations only in either residential or light commercial applications.

NOTE: To ensure proper condensate drainage, unit must be installed in a level position.

PRODUCT DESIGN

The connecting ductwork (Supply and Return) can be connected for horizontal discharge airflow. In the down discharge applications, a matching Roof Curb is recommended.

A return air filter must be installed behind the return air grille(s) or provision must be made for a filter in an accessible location within the return air duct. The minimum filter area should not be less than those sizes listed in the Specification Section. Under no circumstances should the unit be operated without return air filters.

A 3/4" - 14 NPT drain connector is provided for removal of condensate water from the indoor coil. In order to provide proper condensate flow, do not reduce the drain line size.

Refrigerant flow control is achieved by use of restrictor orifices or thermostatic expansion valves (TXV). These models use the FasTest Access Fitting System, with a saddle that is either soldered to the suction and liquid lines or is fastened with a locking nut to the access fitting box (core) and then screwed into the saddle. **Do not remove the core from the saddle until the refrigerant charge has been removed. Failure to do so could result in property damage or personal injury.**

Single Phase - The single phase units use permanent split capacitors (PSC) design compressors. Starting components are therefore not required. A low MFD run capacitor assists the compressor to start and remains in the circuit during operation.

The outdoor fan motors are single phase capacitor type motors.

Air for condensing (cooling) is drawn through the outdoor coil by a propeller fan, and is discharged vertically out the top of the unit. The outdoor coil is designed for .0 static. No additional restriction (ductwork) shall be applied.

Conditioned air is drawn through the filter(s), field installed, across the evaporator coil and back into the conditioned space by the indoor blower.

COMPRESSORS

A scroll is an involute spiral which, when matched with a mating scroll form as shown, generates a series of crescent shaped gas pockets between the two members.

During compression, one scroll remains stationary (fixed scroll) while the other form (orbiting scroll) is allowed to orbit (but not rotate) around the first form.



As this motion occurs, the pockets between the two forms are slowly pushed to the center of the two scrolls while simultaneously being reduced in volume. When the pocket reaches the center of the scroll form, the gas, which is now at a high pressure, is discharged out of a port located at the center.

During compression, several pockets are being compressed simultaneously, resulting in a very smooth process. Both the suction process (outer portion of the scroll members) and the discharge process (inner portion) are continuous.

Some design characteristics of the Compliant Scroll compressor are:

- Compliant Scroll compressors are more tolerant of liquid refrigerant.

NOTE: Even though the compressor section of a Scroll compressor is more tolerant of liquid refrigerant, continued floodback or flooded start conditions may wash oil from the bearing surfaces causing premature bearing failure.

- These Scroll compressors use "POE" or polyolester oil which is NOT compatible with mineral oil based lubricants like 3GS. "POE" oil must be used if additional oil is required.

- Compliant scroll compressors perform "quiet" shutdowns that allow the compressor to restart immediately without the need for a time delay. This compressor will restart even if the system has not equalized.

NOTE: Operating pressures and amp draws may differ from standard reciprocating compressors. This information can be found in the unit's Technical Information Manual.

INDOOR BLOWER MOTOR

GPH16M41** series model package units use a EEM (Energy Efficient Motor) blower motor. The EEM is a 3 Phase brushless DC (single phase AC input), ball bearing construction motor with an integral control module with an internal FCC B EMI filter.

The EEM is continuously powered with line voltage. The switched 24 volt control signal is controlled by the thermostat in the cooling, heat pump and electric heat modes.

APH16M41** series model package units use an ECM motor. The ECM control board is factory set with the dip switch #4 in the "ON" position for single stage units and to the "OFF" position for the 2 stage units. All other dip switches are factory set in the "OFF" position. For most applications, the settings are to be changed according to the electric heat size.

The ECM motor provides many features not available on the traditional PSC motor. These features include:

- Improved Efficiency
- Constant CFM
- Soft Start and Stop
- Improved Humidity Control

PRODUCT DESIGN

ELECTRICAL WIRING

The units are designed for operation at the voltages and frequency as shown on the rating plate. All internal wiring is complete. Ensure the power supply to the compressor contactor is brought to the unit as shown on the supplied unit wiring diagram. The 24V wiring must be connected between the unit control panel and the room thermostat.

The unit transformer is connected for 230V operation. If the unit is to operate on 208V, reconnect the transformer primary lead as shown on the unit wiring diagram.

If it is necessary for the installer to supply additional line voltage wiring to the inside of the package unit, the wiring must comply with all local codes. This wiring must have a minimum temperature rating of 105°C. All line voltage splices must be made inside the unit or heat kit control box.



WARNING

TO AVOID PERSONAL INJURY OR DEATH DUE TO ELECTRIC SHOCK, WIRING TO THE UNIT MUST BE PROPERLY POLARIZED AND GROUNDED.



WARNING

**HIGH VOLTAGE!
DISCONNECT ALL POWER BEFORE CHANGING ANY ELECTRICAL WIRING. MULTIPLE POWER SOURCES MAY BE PRESENT. FAILURE TO DO SO MAY CAUSE PROPERTY DAMAGE, PERSONAL INJURY OR DEATH.**



WARNING

TO AVOID THE RISK OF PROPERTY DAMAGE, PERSONAL INJURY OR FIRE, USE ONLY COPPER CONDUCTORS.

LINE VOLTAGE WIRING

Power supply to the unit must be N.E.C. Class 1, and must comply with all applicable codes. The unit must be electrically grounded in accordance with the local codes or, in their absence, with the latest edition of the National Electrical Code, ANSI/NFPA No. 70, or in Canada, Canadian Electrical Code, C22.1, Part 1. A fused disconnect must be provided and sized in accordance with the unit minimum circuit ampacity.

The best protection for the wiring is the smallest fuse or breaker which will hold the equipment on line during normal operation without nuisance trips. Such a device will provide maximum circuit protection.



WARNING

DO NOT EXCEED THE MAXIMUM OVERCURRENT DEVICE SIZE SHOWN ON THE UNIT DATA PLATE.

All line voltage connections must be made through weather proof fittings. All exterior power supply and ground wiring must be in approved weather proof conduit. Low voltage wiring from the unit control panel to the thermostat requires coded cable.

SYSTEM OPERATION

COOLING

The refrigerant used in the system is R-410A. It is a clear, colorless, non-toxic and non-irritating liquid. R-410A is a 50:50 blend of R-32 and R-125. The boiling point at atmospheric pressure is **-62.9°F**.

A few of the important principles that make the refrigeration cycle possible are: heat always flows from a warmer to a cooler body, under lower pressure a refrigerant will absorb heat and vaporize at a low temperature, the vapors may be drawn off and condensed at a higher pressure and temperature to be used again.

The indoor evaporator coil functions to cool and dehumidify the air conditioned spaces through the evaporative process taking place within the coil tubes.

NOTE: Actual temperatures and pressures are to be obtained from the expanded ratings in the Technical Information Manual.

High temperature, high pressure vapor leaves the compressor through the discharge line and enters the condenser coil. Air drawn through the condenser coil by the condenser fan causes the refrigerant to condense into a liquid by removing heat from the refrigerant. As the refrigerant is cooled below its condensing temperature it becomes subcooled.

The subcooled high pressure liquid refrigerant now leaves the condenser coil via the liquid line until it reaches the indoor expansion device.

As the refrigerant passes through the expansion device and into the evaporator coil a pressure drop is experienced causing the refrigerant to become a low pressure liquid. Low pressure saturated refrigerant enters the evaporator coil where heat is absorbed from the warm air drawn across the coil by the evaporator blower. As the refrigerant passes through the last tubes of the evaporator coil it becomes superheated, that is, it absorbs more heat than is necessary for the refrigerant to vaporize. Maintaining proper superheat assures that liquid refrigerant is not returning to the compressor which can lead to early compressor failure.

Low pressure superheated vapor leaves the evaporator coil and returns through the suction line to the compressor where the cycle begins again.

COOLING CYCLE

Cooling Mode

When the contacts of the room thermostat close, making terminals R to Y1, R to O, and R to G, the low voltage circuit to the contactor is completed starting the compressor and outdoor fan motor. The indoor blower motor is energized at the cool speed.

When the thermostat is satisfied, breaking the circuit between R to Y1 and R to G, the compressor and outdoor fan motor will stop. The indoor blower will stop after the fan off delay.

If the room thermostat fan selector switch should be set to the "on" position then the indoor blower would run continuous rather than cycling with the compressor.

A/GPH16[24-60]M41*

HEATING CYCLE

Heat Pump Mode

On a call for first stage heat, the contacts of the room thermostat close. This energizes terminals R to Y1 and R to G, the low voltage circuit to the contactor is completed starting the compressor and outdoor fan motor. This also energizes the indoor blower motor.

When the thermostat is satisfied, breaking the circuit between R to Y1 and R to G, the compressor and outdoor fan motor will stop. The indoor blower will stop after the programmed off delay.

During first stage operation the stat calls for second stage heat. This energizes terminals R to Y2. This powers voltage to the compressor solenoid allowing the compressor to shift to full capacity. When the thermostat is satisfied, breaking the circuit between R to Y1, R to Y2 and R to G, the compressor and outdoor fan motor will stop. The indoor blower will stop after the programmed off delay on the motor.

When auxiliary electric heaters are used the Aux stage heating contacts in the room thermostat close, which would be wired to W1 at the unit low voltage connections, this would energize the coil(s) of the electric heat contactor(s)/sequencer(s). Contacts within the contactor(s)/Sequencer(s) will close, bringing on the electric resistance heaters. If auxiliary electric heaters should be used, they may be controlled by outdoor thermostats (OT18-60A or OT/EHR18-60A).

Emergency Heat Mode (Heat Pumps)

NOTE: The following only applies if the unit has an approved electric heat kit installed for auxiliary heating.

With the thermostat set to the emergency heat position, R to W2/E will be energized. This will energize the electric heat contactor(s)/sequencer(s) and the motor. The electric heat will be energized through the normally open contacts of the electric heat contactor(s)/sequencer(s). The indoor blower will be energized through W2/E from the thermostat.

DEFROST CYCLE

Package Heat Pumps

The defrosting of the outdoor coil is jointly controlled by the defrost control board and the defrost thermostat.

Solid State Defrost Control

During operation the power to the circuit board is controlled by a temperature sensor, which is clamped to a feeder tube entering the outdoor coil. Defrost timing periods of 30, 60, or 90 minutes may be selected by setting the circuit board jumper to 30, 60, or 90 respectively. Accumulation of time for the timing period selected starts when the sensor closes (approximately 34° F), and when the room thermostat calls for heat. At the end of the timing period, the unit's defrost cycle will be initiated provided the sensor remains closed. When the sensor opens (approximately 60° F), the defrost cycle is terminated and the timing period is reset. If the defrost cycle is not terminated due to the sensor temperature, a twelve minute override interrupts the unit's defrost period.

SYSTEM OPERATION

FAN OPERATION

Continuous Fan Mode

If the thermostat calls for continuous fan, the indoor blower will be energized from the G terminal of the thermostat .

If a call for heat or cool occurs during a continuous fan call, the unit will always recognize the demand call and switch the fan to the speed for the demand.

If the thermostat is not calling for heat or cool, and the fan switch on the thermostat is returned to the automatic position, the fan will stop after the programmed off delay.

SYSTEM OPERATION

A/GPH16[24-60]M41*

Typical Heat Pump System in Cooling

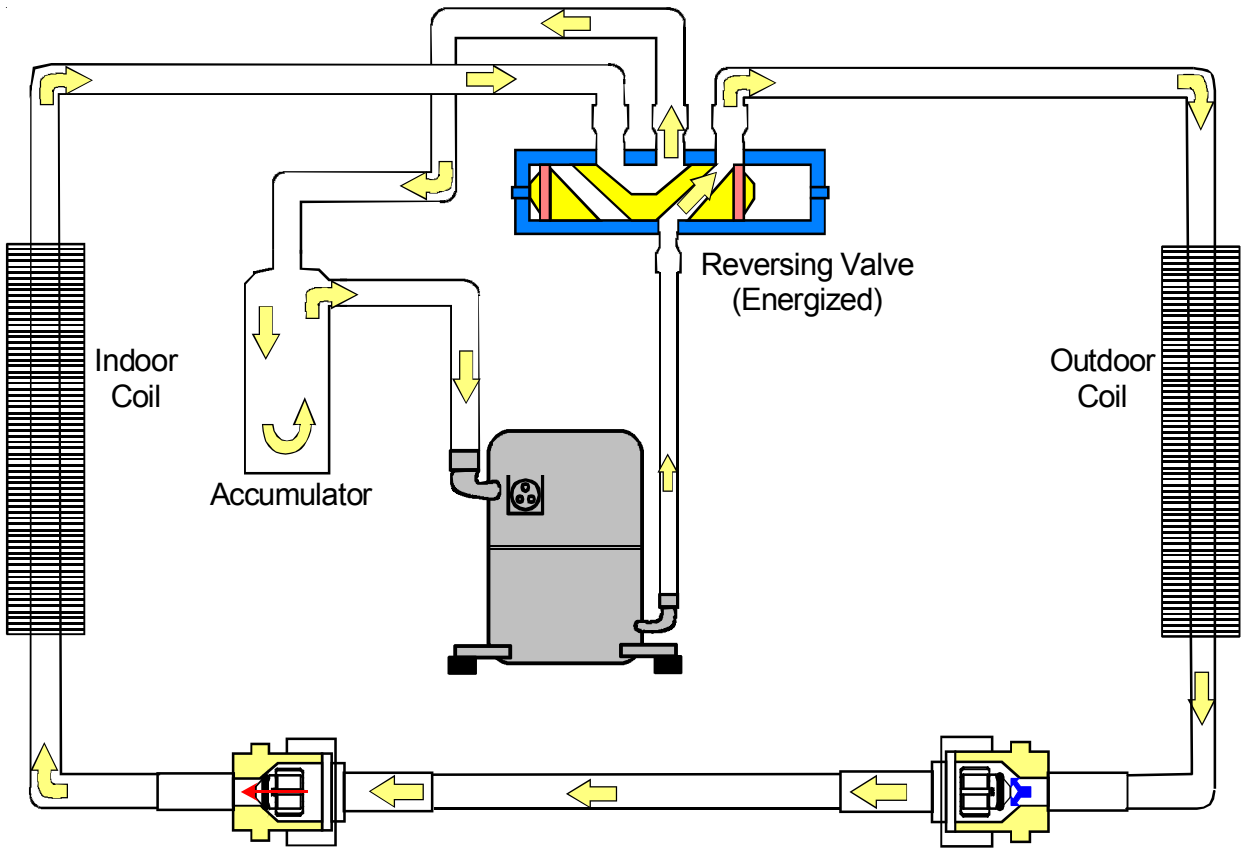

Typical Heat Pump System in Heating

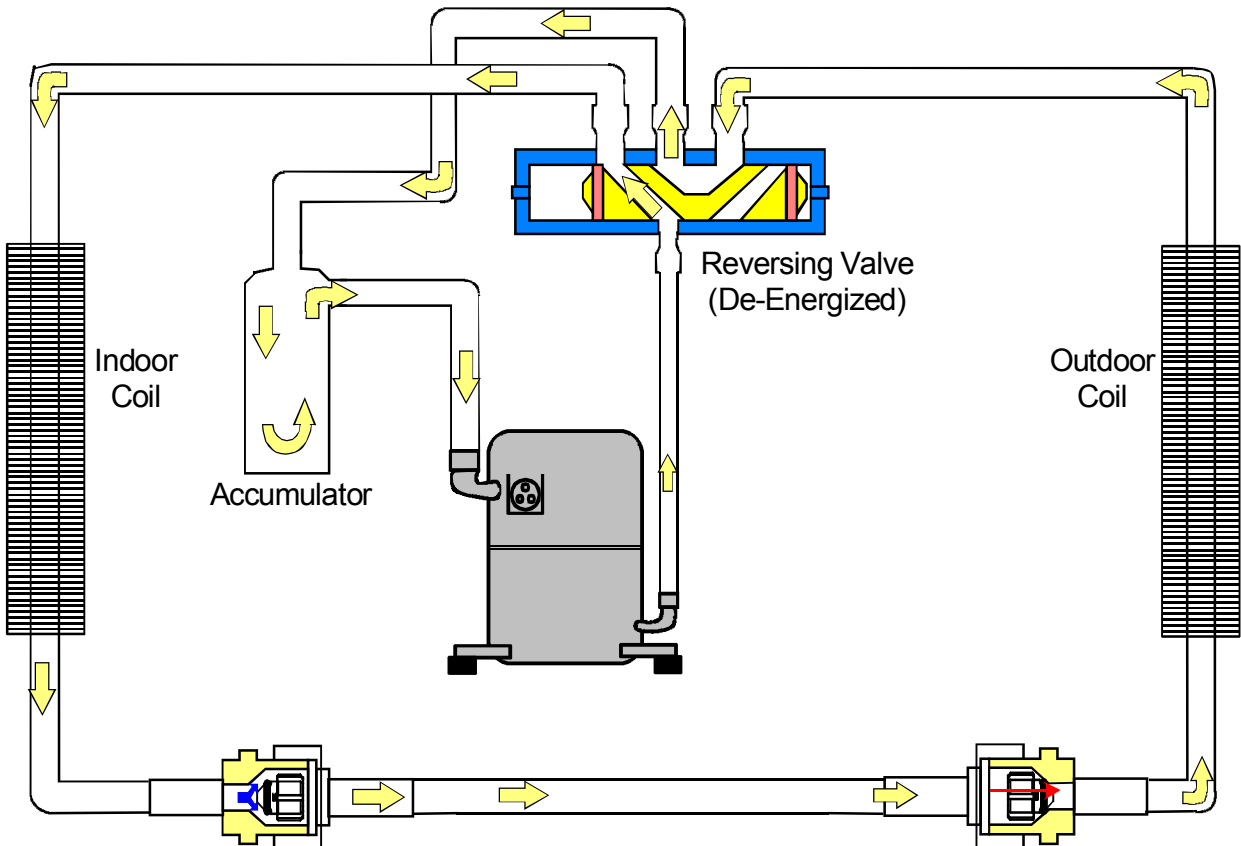

SCHEDULED MAINTENANCE

Package heat pumps require regularly scheduled maintenance to preserve high performance standards, prolong the service life of the equipment, and lessen the chances of costly failure.

In many instances the owner may be able to perform some of the maintenance; however, the advantage of a service contract, which places all maintenance in the hands of a trained serviceman, should be pointed out to the owner.

 **WARNING**



**HIGH VOLTAGE!
DISCONNECT ALL POWER BEFORE
SERVICING OR INSTALLING THIS UNIT.
MULTIPLE POWER SOURCES MAY BE
PRESENT. FAILURE TO DO SO MAY CAUSE PROPERTY
DAMAGE, PERSONAL INJURY OR DEATH.**

3. Amprobe - measure current.
4. Volt-Ohm Meter - testing continuity, capacitors, motor windings and voltage.
5. Accurate Leak Detector - testing for refrigerant leaks.
6. High Vacuum Pump - evacuation.
7. Electric Vacuum Gauge, Manifold Gauges and high vacuum hoses - to measure and obtain proper vacuum.
8. Accurate Charging Cylinder or Electronic Scale - measure proper refrigerant charge.
9. Inclined Manometer - measure static pressure and pressure drop across coils.

Other recording type instruments can be essential in solving abnormal problems, however, in many instances they may be rented from local sources.

Proper equipment promotes faster, more efficient service, and accurate repairs with less call backs.

ONCE A MONTH

1. Inspect the return filters of the evaporator unit and clean or change if necessary. **NOTE:** Depending on operation conditions, it may be necessary to clean or replace the filters more often. If permanent type filters are used, they should be washed with warm water and dried.
2. When operating on the cooling cycle, inspect the condensate line piping from the evaporator coil. Make sure the piping is clear for proper condensate flow.

ONCE A YEAR

Qualified Service Personnel Only

1. Clean the indoor and outdoor coils.
2. Clean the cabinet inside and out .
3. Motors are permanently lubricated and do not require oiling. **TO AVOID PREMATURE MOTOR FAILURE, DO NOT OIL.**
4. Manually rotate the outdoor fan and indoor blower to be sure they run freely.
5. Inspect the control panel wiring, compressor connections, and all other component wiring to be sure all connections are tight. Inspect wire insulation to be certain that it is good.
6. Check the contacts of the compressor contactor. If they are burned or pitted, replace the contactor.
7. Using a halide or electronic leak detector, check all piping and etc. for refrigerant leaks.

TEST EQUIPMENT

Proper test equipment for accurate diagnosis is as essential as regular hand tools.

The following is a must for every service technician and service shop:

1. Thermocouple type temperature meter - measure dry bulb temperature.
2. Sling psychrometer- measure relative humidity and wet bulb temperature.

SERVICING

COOLING /HEAT PUMP- SERVICE ANALYSIS GUIDE

Complaint	No Cooling						Unsatisfactory Cooling/Heating						System Operating Pressures				Test Method Remedy	See Service Procedure Ref.		
	System will not start	Compressor will not start-fan runs	Comp. and Cond. Fan will not start	Evaporator fan will not start	Condenser fan will not start	Compressor runs - goes off on overload	Compressor cycles on overload	System runs continuously - little cooling/hig	Too cool and then too warm	Not cool enough on warm days	Certain areas too cool, others too warm	Compressor is noisy	System runs -blows cold air in heating	Unit will not terminate defrost	Unit will not defrost	Low suction pressure			Low head pressure	High suction pressure
Power Failure	•																		Test Voltage	S-1
Blown Fuse	•		•																Inspect Fuse Size & Type	S-1
Unbalanced Power, 3PH		•				•	•												Test Voltage	S-1
Loose Connection	•			•		•													Inspect Connection - Tighten	S-2, S-3
Shorted or Broken Wires	•	•	•	•	•	•													Test Circuits With Ohmmeter	S-2, S-3
Open Fan Overload				•	•														Test Continuity of Overload	S-17A
Faulty Thermostat	•		•	•				•											Test continuity of Thermostat & Wiring	S-3
Faulty Transformer	•		•																Check control circuit with voltmeter	S-4
Shorted or Open Capacitor		•			•	•													Test Capacitor	S-15
Internal Compressor Overload Open		•										♦							Test Continuity of Overload	S-17A
Shorted or Grounded Compressor		•				•													Test Motor Windings	S-17B
Compressor Stuck		•				•							♦						Use Test Cord	S-17D
Faulty Compressor Contactor			•		•	•													Test continuity of Coil & Contacts	S-7, S-8
Compressor High Stage Not Working							•	•				♦							Test Voltage to Unloader Plug, Test Plug	S-17C
Open Control Circuit				•															Test Control Circuit with Voltmeter	S-4, S-11, S-12
Low Voltage		•				•	•												Test Voltage	S-1
Faulty Evap. Fan Motor				•											•			♦	Repair or Replace	S-16
Shorted or Grounded Fan Motor					•													•	Test Motor Windings	S-16A,D
Improper Cooling Anticipator						•		•											Check resistance of Anticipator	S-3B
Shortage of Refrigerant						•	•					♦			•	•			Test For Leaks, Add Refrigerant	S-101,103
Restricted Liquid Line						•	•								•	•	•		Remove Restriction, Replace Restricted Part	S-112
Open Element or Limit on Elec. Heater							♦					♦							Test Heater Element and Controls	S-26,S-27
Dirty Air Filter						•		•	•						•			♦	Inspect Filter-Clean or Replace	
Dirty Indoor Coil						•		•	•						•			♦	Inspect Coil - Clean	
Not enough air across Indoor Coil						•		•	•						•			♦	Check Blower Speed, Duct Static Press, Filter	S-200
Too much air across Indoor Coil								•								♦	•		Reduce Blower Speed	S-200
Overcharge of Refrigerant						•	•				•	♦					•	•	Recover Part of Charge	S-113
Dirty Outdoor Coil					•	•		•							♦			•	Inspect Coil - Clean	
Noncondensibles						•		•				♦						•	Recover Charge, Evacuate, Recharge	S-114
Recirculation of Condensing Air						•		•										•	Remove Obstruction to Air Flow	
Infiltration of Outdoor Air						•		•	•										Check Windows, Doors, Vent Fans, Etc.	
Improperly Located Thermostat						•		•											Relocate Thermostat	
Air Flow Unbalanced								•	•										Readjust Air Volume Dampers	
System Undersized							•	•											Refigure Cooling Load	
Broken Internal Parts												•	♦						Replace Compressor	S-115
Broken Valves							•					•			•	•			Test Compressor Efficiency	S-104
Inefficient Compressor							•					♦				•	•		Test Compressor Efficiency	S-104
Loose Hold-down Bolts											•								Tighten Bolts	
Faulty Reversing Valve					•							♦	♦	♦	♦	♦	♦	♦	Replace Valve or Solenoid	S-21, 122
Faulty Defrost Control				•								♦	♦	♦	♦	♦		♦	Test Control	S-24
Faulty Defrost Thermostat												♦	♦	♦	♦	♦	♦	♦	Test Defrost Thermostat	S-25
Flow rator Not Seating Properly						•										•	•		Check Flow rator & Seat or Replace Flow rator	S-111

• Cooling or Heating Cycle (Heat Pump)

♦ Heating Cycle Only (Heat Pump)

SERVICING

S-1 CHECKING VOLTAGE

WARNING

**HIGH VOLTAGE!
DISCONNECT ALL POWER BEFORE
SERVICING OR INSTALLING THIS UNIT.
MULTIPLE POWER SOURCES MAY BE
PRESENT. FAILURE TO DO SO MAY CAUSE PROPERTY
DAMAGE, PERSONAL INJURY OR DEATH.**

1. Remove doors, control panel cover, etc. from unit being tested.

With power ON:

WARNING

LINE VOLTAGE NOW PRESENT.

2. Using a voltmeter, measure the voltage across terminals L1 and L2 of the contactor for single phase units, and L3, for 3 phase units.
3. No reading - indicates open wiring, open fuse(s) no power or etc. from unit to fused disconnect service. Repair as needed.
4. With ample voltage at line voltage connectors, energize the unit.
5. Measure the voltage with the unit starting and operating, and determine the unit Locked Rotor Voltage.

Locked Rotor Voltage is the actual voltage available at the compressor during starting, locked rotor, or a stalled condition. Measured voltage should be above minimum listed in chart below.

To measure Locked Rotor Voltage attach a voltmeter to the run "R" and common "C" terminals of the compressor, or to the T₁ and T₂ terminals of the contactor. Start the unit and allow the compressor to run for several seconds, then shut down the unit. Immediately attempt to restart the unit while measuring the Locked Rotor Voltage.

6. Should read within the voltage tabulation as shown. If the voltage falls below the minimum voltage, check the line wire size. Long runs of undersized wire can cause low voltage. If wire size is adequate, notify the local power company in regards to either low or high voltage.

Unit Supply Voltage		
Voltage	Min.	Max.
460	437	506
208/230	198	253

Three phase units require a balanced 3 phase power supply to operate. If the percentage of voltage imbalance exceeds 3% the unit must not be operated until the voltage condition is corrected.

$$\% \text{ Voltage Imbalance} = \frac{\text{Max. Voltage Deviation From Average Voltage}}{\text{Average Voltage}} \times 100$$

To find the percentage of imbalance, measure the incoming power supply.

L1 - L2 = 240V	
L1 - L3 = 232V	Avg. V = $\frac{710}{3} = 236.7$
L2 - L3 = 238V	3
Total 710V	

To find Max. deviation:

240 - 236.7 = +3.3

232 - 236.7 = -4.7

238 - 236.7 = +1.3

Max deviation was 4.7V

$$\% \text{ Voltage Imbalance} = \frac{4.7}{236.7} = 1.99\%$$

If the percentage of imbalance had exceeded 3%, it must be determined if the imbalance is in the incoming power supply or the equipment. To do this rotate the legs of the incoming power and retest voltage as shown below.

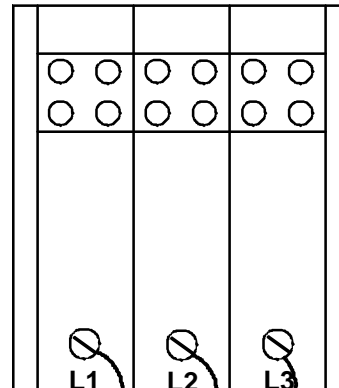

L1 - L2 = 240V
L1 - L3 = 227V
L2 - L3 = 238V

Rotate all 3 incoming legs as shown.

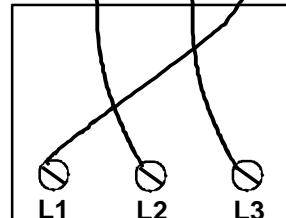

L1 - L2 = 227V
L1 - L3 = 238V
L2 - L3 = 240V

By the voltage readings we see that the imbalance rotated or traveled with the switching of the incoming legs. Therefore the problem lies within the incoming power supply.

If the imbalance had not changed then the problem would lie within the equipment. Check for current leakage, shorted motors, etc.

Wiring is subject to change. Always refer to the wiring diagram on the unit for the most up-to-date wiring.

SERVICING

S-2 CHECKING WIRING

 **WARNING**



**HIGH VOLTAGE!
DISCONNECT ALL POWER BEFORE
SERVICING OR INSTALLING THIS UNIT.
MULTIPLE POWER SOURCES MAY BE
PRESENT. FAILURE TO DO SO MAY CAUSE PROPERTY
DAMAGE, PERSONAL INJURY OR DEATH.**

1. Check wiring visually for signs of overheating, damaged insulation and loose connections.
2. Use an ohmmeter to check continuity of any suspected open wires.
3. If any wires must be replaced, replace with comparable gauge and insulation thickness.

S-3 CHECKING THERMOSTAT, WIRING, AND ANTICIPATOR

S-3A THERMOSTAT AND WIRING

 **WARNING**

LINE VOLTAGE NOW PRESENT.

With power ON and thermostat calling for cooling.

1. Use a voltmeter to verify 24 volts present at thermostat wires C and R.
2. If no voltage present, check transformer and transformer wiring. If 24 volts present, proceed to step 3.
3. Use a voltmeter to check for 24 volts at thermostat wires C and Y.
4. No voltage indicates trouble in the thermostat, wiring or external transformer source.
5. Check the continuity of the thermostat and wiring. Repair or replace as necessary.

Indoor Blower Motor

With power ON:

 **WARNING**

LINE VOLTAGE NOW PRESENT.

1. Use a voltmeter to verify 24 volts present at thermostat wires C and R.
2. If no voltage present, check transformer and transformer wiring. If 24 volts present, proceed to step 3.
3. Set fan selector switch at thermostat to "ON" position.
4. With voltmeter, check for 24 volts at wires C and G.

5. No voltage, indicates the trouble is in the thermostat or wiring.
6. Check the continuity of the thermostat and wiring. Repair or replace as necessary.

S-3B COOLING ANTICIPATOR

The cooling anticipator is a small heater (resistor) in the thermostat. During the "off" cycle it heats the bimetal element helping the thermostat call for the next cooling cycle. This prevents the room temperature from rising too high before the system is restarted. A properly sized anticipator should maintain room temperature within 1 1/2 to 2 degree range.

The anticipator is supplied in the thermostat and is not to be replaced. If the anticipator should fail for any reason, the thermostat must be changed.

S-3C HEATING ANTICIPATOR

The heating anticipator is a wire-wound adjustable heater, which is energized during the "ON" cycle to help prevent overheating of the conditioned space.

The anticipator is a part of the thermostat and if it should fail for any reason, the thermostat must be replaced. See the following for recommended heater anticipator setting.

To determine the proper setting, use an amp meter to measure the amperage on the "W" wire going to the thermostat.

Use an amprobe as shown below. Wrap 10 turns of thermostat wire around the stationary jaw of the amprobe and divide the reading by 10.

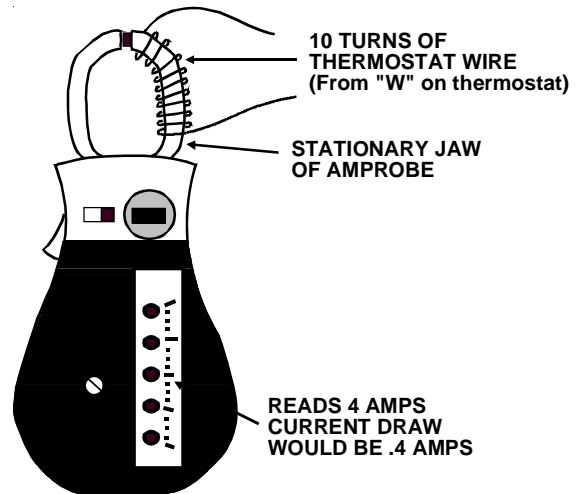



Checking Heat Anticipator Amp Draw

SERVICING

S-4 CHECKING TRANSFORMER AND CONTROL CIRCUIT

A step-down transformer (208/240 volt primary to 24 volt secondary) is provided with each package unit. This allows ample capacity for use with resistance heaters.

 **WARNING**



HIGH VOLTAGE!
DISCONNECT ALL POWER BEFORE SERVICING OR INSTALLING THIS UNIT. MULTIPLE POWER SOURCES MAY BE PRESENT. FAILURE TO DO SO MAY CAUSE PROPERTY DAMAGE, PERSONAL INJURY OR DEATH.

1. Remove control panel cover or etc. to gain access to transformer.

With power ON:

 **WARNING**

LINE VOLTAGE NOW PRESENT.

2. Using a voltmeter, check voltage across secondary voltage side of transformer (R to C).
3. No voltage indicates faulty transformer, bad wiring, or bad splices.
4. Check transformer primary voltage at incoming line voltage connections and/or splices.
5. If line voltage is present at the primary voltage side of the transformer and 24 volts is not present on the secondary side, then the transformer is inoperative. Replace.

S-7 CHECKING CONTACTOR AND/OR RELAYS

The compressor contactor and other relay holding coils are wired into the low or line voltage circuits. When the control circuit is energized the coil pulls in the normally open contacts or opens the normally closed contacts. When the coil is de-energized, springs return the contacts to their normal position.

 **WARNING**

DISCONNECT POWER SUPPLY BEFORE SERVICING.

1. Remove the leads from the holding coil.
2. Using an ohmmeter, test across the coil terminals.

If the coil does not test continuous, replace the relay or contactor.

S-8 CHECKING CONTACTOR CONTACTS

 **WARNING**

DISCONNECT POWER SUPPLY BEFORE SERVICING.

SINGLE PHASE

1. Disconnect the wire leads from the terminal (T) side of the contactor.
2. With power ON, energize the contactor.

 **WARNING**

LINE VOLTAGE NOW PRESENT.

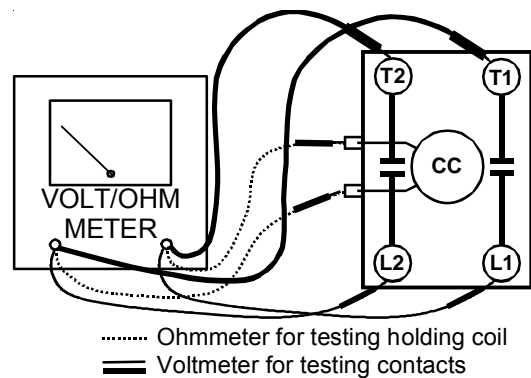

TESTING COMPRESSOR CONTACTOR (Single Phase)

3. Using a voltmeter, test across terminals.
 - A. L1 to L2 - No voltage. Check breaker or fuses on main power supply. If voltage present, proceed to step B.
 - B. T1 to T2 - Meter should read the same as L1 to L2 in step A. If voltage readings are not the same as step A, replace contactor.

THREE PHASE

Using a voltmeter, test across terminals:

- A. L1-L2, L1-L3, and L2-L3 - If voltage is present, proceed to B. If voltage is not present, check breaker or fuses on main power supply..
- B. T1-T2, T1-T3, and T2-T3 - If voltage readings are not the same as in "A", replace contactor.

SERVICING

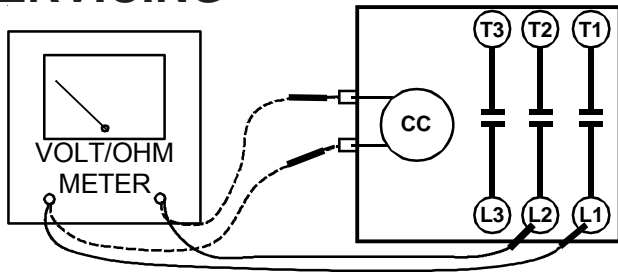

---- Ohmmeter for testing holding coil
— Voltmeter for testing contacts

TESTING COMPRESSOR CONTACTOR (Three-phase)

S-11 CHECKING LOSS OF CHARGE PROTECTOR

(Heat Pump Models)

The loss of charge protector senses the pressure in the liquid line and will open its contacts on a drop in pressure. The low pressure control will automatically reset itself with a rise in pressure.

The low pressure control is designed to cut-out (open) at approximately 50 PSIG. It will automatically cut-in (close) at approximately 95 PSIG.

Test for continuity using a VOM and if not as above, replace the control.

S-12 CHECKING HIGH PRESSURE CONTROL

WARNING

**HIGH VOLTAGE!
DISCONNECT ALL POWER BEFORE
SERVICING OR INSTALLING THIS UNIT.
MULTIPLE POWER SOURCES MAY BE
PRESENT. FAILURE TO DO SO MAY CAUSE PROPERTY
DAMAGE, PERSONAL INJURY OR DEATH.**

The high pressure control capillary senses the pressure in the compressor discharge line. If abnormally high condensing pressures develop, the contacts of the control open, breaking the control circuit before the compressor motor overloads. This control is automatically reset.

1. Using an ohmmeter, check across terminals of high pressure control, with wire removed. If not continuous, the contacts are open.
3. Attach a gauge to the dill valve port on the base valve.

With power ON:

WARNING

LINE VOLTAGE NOW PRESENT.

4. Start the system and place a piece of cardboard in front of the condenser coil, raising the condensing pressure.

5. Check pressure at which the high pressure control cuts-out.

If it cuts-out at 660 PSIG \pm 10 PSIG, it is operating normally (See causes for high head pressure in Service Problem Analysis Guide). If it cuts out below this pressure range, replace the control.

S-15 CHECKING CAPACITOR

CAPACITOR, RUN

A run capacitor is wired across the auxiliary and main windings of a single phase permanent split capacitor motor. The capacitor's primary function is to reduce the line current while greatly improving the torque characteristics of a motor. This is accomplished by using the 90° phase relationship between the capacitor current and voltage in conjunction with the motor windings so that the motor will give two phase operation when connected to a single phase circuit. The capacitor also reduces the line current to the motor by improving the power factor.

CAPACITOR, START

SCROLL COMPRESSOR MODELS

Hard start components are not required on Scroll compressor equipped units due to a non-replaceable check valve located in the discharge line of the compressor. However hard start kits are available and may improve low voltage starting characteristics. Only hard start kits approved by Goodman® or Copeland should be used. "Kick Start" and/or "Super Boost" kits are not approved start assist devices.

This check valve closes off high side pressure to the compressor after shut down allowing equalization through the scroll flanks. Equalization requires only about one or two seconds during which time the compressor may turn backwards.

MODELS EQUIPPED WITH A HARD START DEVICE

A start capacitor is wired in parallel with the run capacitor to increase the starting torque. The start capacitor is of the electrolytic type, rather than metallized polypropylene as used in the run capacitor.

A switching device must be wired in series with the capacitor to remove it from the electrical circuit after the compressor starts to run. Not removing the start capacitor will overheat the capacitor and burn out the compressor windings.

These capacitors have a 15,000 ohm, 2 watt resistor wired across its terminals. The object of the resistor is to discharge the capacitor under certain operating conditions, rather than having it discharge across the closing of the contacts within the switching device such as the Start Relay, and to reduce the chance of shock to the servicer. See the Servicing Section for specific information concerning capacitors.

RELAY, START

A potential or voltage type relay is used to take the start capacitor out of the circuit once the motor comes up to speed. This type of relay is position sensitive. The normally closed contacts are wired in series with the start capacitor and the relay holding coil is wired parallel with the start winding. As the motor starts and comes up to speed, the increase in volt-

SERVICING

age across the start winding will energize the start relay holding coil and open the contacts to the start capacitor.

Two quick ways to test a capacitor are a resistance and a capacitance check.

S-15A RESISTANCE CHECK

WARNING



HIGH VOLTAGE!
DISCONNECT ALL POWER BEFORE SERVICING OR INSTALLING THIS UNIT.
MULTIPLE POWER SOURCES MAY BE PRESENT. FAILURE TO DO SO MAY CAUSE PROPERTY DAMAGE, PERSONAL INJURY OR DEATH.

1. Discharge capacitor and remove wire leads.

WARNING

DISCHARGE CAPACITOR THROUGH A 20 TO 30 OHM RESISTOR BEFORE HANDLING.

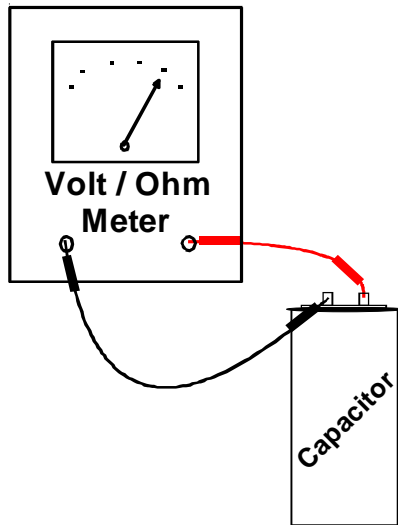

TESTING CAPACITOR RESISTANCE

2. Set an ohmmeter on its highest ohm scale and connect the leads to the capacitor -
 - A. Good Condition - indicator swings to zero and slowly returns to infinity. (Start capacitor with bleed resistor will not return to infinity. It will still read the resistance of the resistor).
 - B. Shorted - indicator swings to zero and stops there - replace.
 - C. Open - no reading - replace. (Start capacitor would read resistor resistance).

S-15B CAPACITANCE CHECK

WARNING

DISCHARGE CAPACITOR THROUGH A 20 TO 30 OHM RESISTOR BEFORE HANDLING.

Using a hookup as shown below, take the amperage and voltage readings and use them in the formula:

$$\text{Capacitance (MFD)} = \frac{2650 \times \text{Amperage}}{\text{Voltage}}$$

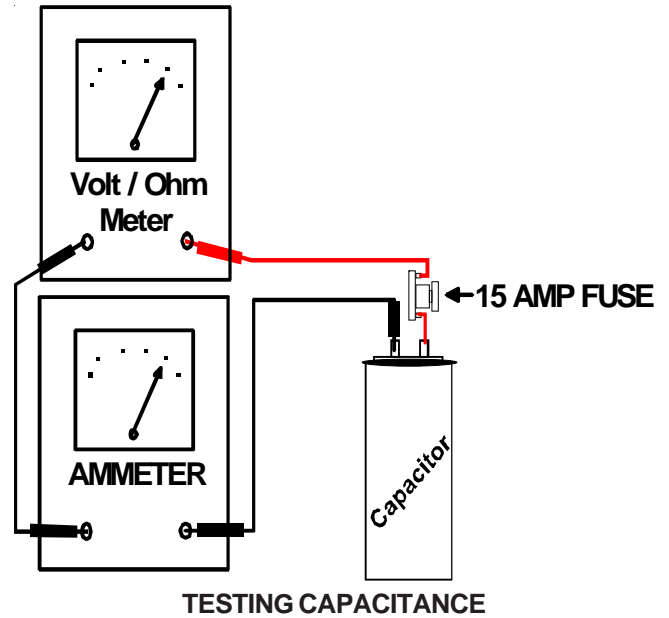

SERVICING

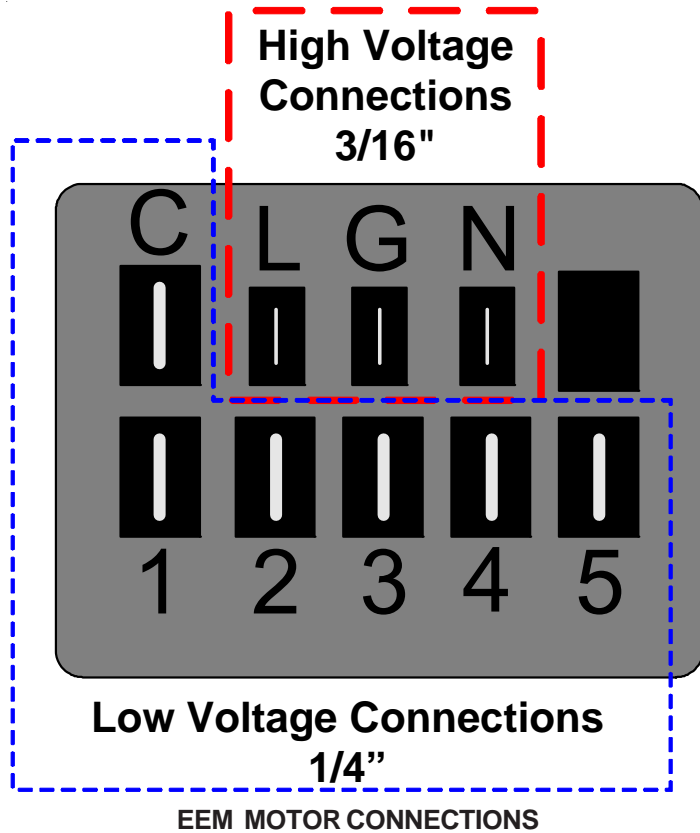

WARNING
 Discharge capacitor through a 20 to 30 OHM resistor before handling.

$$\text{Capacitance (MFD)} = \frac{2650 \times \text{Amperage}}{\text{Voltage}}$$

S-16A CHECKING FAN AND BLOWER MOTOR WINDINGS (PSC MOTORS)

The auto reset fan motor overload is designed to protect the motor against high temperature and high amperage conditions by breaking the common circuit within the motor, similar to the compressor internal overload. However, heat generated within the motor is faster to dissipate than the compressor, allow at least 45 minutes for the overload to reset, then retest.

WARNING
HIGH VOLTAGE!
 Disconnect ALL power before servicing or installing this unit. Multiple power sources may be present. Failure to do so may cause property damage, personal injury or death.

1. Remove the motor leads from its respective connection points and capacitor (if applicable).
2. Check the continuity between each of the motor leads.

3. Touch one probe of the ohmmeter to the motor frame (ground) and the other probe in turn to each lead.

If the windings do not test continuous or a reading is obtained from lead to ground, replace the motor.

S-16C CHECKING ECM MOTOR WINDINGS

WARNING
HIGH VOLTAGE!
 Disconnect ALL power before servicing or installing this unit. Multiple power sources may be present. Failure to do so may cause property damage, personal injury or death.

1. Disconnect the 5-pin and the 16-pin connectors from the ECM power head.
2. Remove the 2 screws securing the ECM power head and separate it from the motor.
3. Disconnect the 3-pin motor connector from the power head and lay it aside.
4. Using an ohmmeter, check the motor windings for continuity to ground (pins to motor shell). If the ohmmeter indicates continuity to ground, the motor is defective and must be replaced.
5. Using an ohmmeter, check the windings for continuity (pin to pin). If no continuity is indicated, the thermal limit (over load) device may be open. Allow motor to cool and retest.

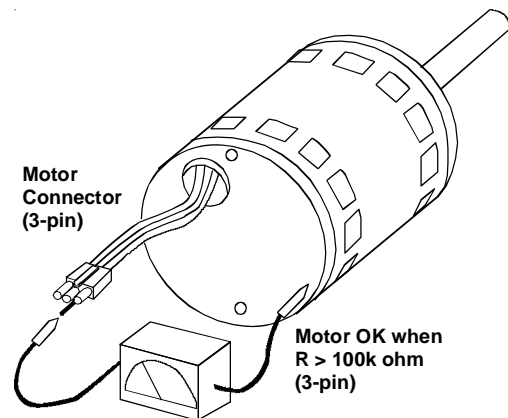

WINDING TEST

S-16D CHECKING EEM MOTORS

Applies to A/GPG15*****41A*

The EEM motor is a one piece, fully encapsulated, 3 phase brushless DC (single phase AC input) motor with ball bearing construction. Unlike the ECM 2.3/2.5 motors, the EEM features an integral control module.

Note: The GE TECMate will not currently operate the EEM motor.

SERVICING

1. Using a voltmeter, check for 230 volts to the motor connections L and N. If 230 volts is present, proceed to step 2. If 230 volts is not present, check the line voltage circuit to the motor.
2. Using a voltmeter, check for 24 volts from terminal C to either terminal 1, 2, 3, 4, or 5, depending on which tap is being used, at the motor. If voltage present, proceed to step 3. If no voltage, check 24 volt circuit to motor.
3. If voltage was present in steps 1 and 2, the motor has failed and will need to be replaced.

Note: When replacing motor, ensure the belly band is between the vents on the motor and the wiring has the proper drip loop to prevent condensate from entering the motor.

S-17C UNLOADER TEST PROCEDURE

(2 Stage Compressors Only)

A nominal 24-volt direct current coil activates the internal unloader solenoid. The input control circuit voltage must be 18 to 28 volt ac. The coil power requirement is 20 VA. The external electrical connection is made with a molded plug assembly. This plug contains a full wave rectifier to supply direct current to the unloader coil.



**UNLOADER SOLENOID
(Molded Plug)**

Unloader Test Procedure

If it is suspected that the unloader is not working, the following methods may be used to verify operation.

1. Operate the system and measure compressor current. Cycle the unloader ON and OFF at 10 second intervals. The compressor amperage should go up or down at least 25 percent.
2. If step one does not give the expected results, shut unit off. Apply 18 to 28 volt ac to the unloader molded plug leads and listen for a click as the solenoid pulls in. Remove power and listen for another click as the unloader returns to its original position.

3. If clicks can't be heard, shut off power and remove the control circuit molded plug from the compressor and measure the unloader coil resistance. The resistance should be 32 to 60 ohms, depending on compressor temperature.
4. Next check the molded plug.
 - A. Voltage check: Apply control voltage to the plug wires (18 to 28 volt ac). The measured **dc** voltage at the female connectors in the plug should be around 15 to 27 vdc.
 - B. Resistance check: Measure the resistance from the end of one molded plug lead to either of the two female connectors in the plug. One of the connectors should read close to zero ohms while the other should read infinity. Repeat with other wire. The same female connector as before should read zero while the other connector again reads infinity. Reverse polarity on the ohmmeter leads and repeat. The female connector that read infinity previously should now read close to zero ohms.
 - C. Replace plug if either of these test methods doesn't show the desired results.

S-17 CHECKING COMPRESSOR WINDINGS



HERMETIC COMPRESSOR ELECTRICAL TERMINAL VENTING CAN BE DANGEROUS. WHEN INSULATING MATERIAL WHICH SUPPORTS A HERMETIC COMPRESSOR OR ELECTRICAL TERMINAL SUDDENLY DISINTEGRATES DUE TO PHYSICAL ABUSE OR AS A RESULT OF AN ELECTRICAL SHORT BETWEEN THE TERMINAL AND THE COMPRESSOR HOUSING, THE TERMINAL MAY BE EXPELLED, VENTING THE VAPOR AND LIQUID CONTENTS OF THE COMPRESSOR HOUSING AND SYSTEM.

If the compressor terminal PROTECTIVE COVER and gasket (if required) is not properly in place and secured, there is a remote possibility if a terminal vents, that the vaporous and liquid discharge can be ignited, spouting flames several feet, causing potentially severe or fatal injury to anyone in its path.

This discharge can be ignited external to the compressor if the terminal cover is not properly in place and if the discharge impinges on a sufficient heat source.

Ignition of the discharge can also occur at the venting terminal or inside the compressor, if there is sufficient contaminant air present in the system and an electrical arc occurs as the terminal vents.

Ignition cannot occur at the venting terminal without the presence of contaminant air, and cannot occur externally from the venting terminal without the presence of an external ignition source.

Wiring is subject to change. Always refer to the wiring diagram on the unit for the most up-to-date wiring.

SERVICING

Therefore, proper evacuation of a hermetic system is essential at the time of manufacture and during servicing.

To reduce the possibility of external ignition, all open flame, electrical power, and other heat sources should be extinguished or turned off prior to servicing a system.

If the following test indicates shorted, grounded or open windings, see procedure S-19 for the next steps to be taken.

S-17A RESISTANCE TEST

Each compressor is equipped with an internal overload.

The line break internal overload senses both motor amperage and winding temperature. High motor temperature or amperage heats the disc causing it to open, breaking the common circuit within the compressor on single phase units. The three phase internal overload will open all three legs.

Heat generated within the compressor shell, usually due to recycling of the motor, high amperage or insufficient gas to cool the motor, is slow to dissipate, allow at least three to four hours for it to cool and reset, then retest.

WARNING



**HIGH VOLTAGE!
DISCONNECT ALL POWER BEFORE
SERVICING OR INSTALLING THIS UNIT.
MULTIPLE POWER SOURCES MAY BE
PRESENT. FAILURE TO DO SO MAY CAUSE PROPERTY
DAMAGE, PERSONAL INJURY OR DEATH.**

1. Remove the leads from the compressor terminals.

WARNING

SEE WARNINGS S-17 BEFORE REMOVING COMPRESSOR TERMINAL COVER.

2. Using an ohmmeter, test continuity between terminals S-R, C-R, and C-S, on single phase units or terminals T1, T2 and T3, on 3 phase units.

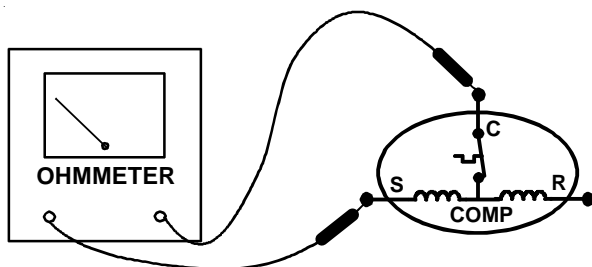

TESTING COMPRESSOR WINDINGS

If either winding does not test continuous, replace the compressor.

NOTE: If an open compressor is indicated allow ample time for the internal overload to reset before replacing compressor.

S-17B GROUND TEST

If fuse, circuit breaker, ground fault protective device, etc., has tripped, this is a strong indication that an electrical problem exists and must be found and corrected. The circuit protective device rating must be checked and its maximum rating should coincide with that marked on the equipment nameplate.

With the terminal protective cover in place, it is acceptable to replace the fuse or reset the circuit breaker ONE TIME ONLY to see if it was just a nuisance opening. If it opens again, DO NOT continue to reset.

Disconnect all power to unit, making sure that all power legs are open.

1. DO NOT remove protective terminal cover. Disconnect the three leads going to the compressor terminals at the nearest point to the compressor.

WARNING

DAMAGE CAN OCCUR TO THE GLASS EMBEDDED TERMINALS IF THE LEADS ARE NOT PROPERLY REMOVED. THIS CAN RESULT IN TERMINAL AND HOT OIL DISCHARGING.

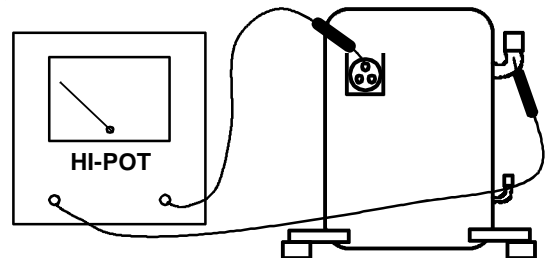

COMPRESSOR GROUND TEST

2. Identify the leads and using a Megger, Hi-Potential Ground Tester, or other suitable instrument which puts out a voltage between 300 and 1500 volts, check for a ground separately between each of the three leads and ground (such as an unpainted tube on the compressor). Do not use a low voltage output instrument such as a volt-ohmmeter.
3. If a ground is indicated, then carefully remove the compressor terminal protective cover and inspect for loose leads or insulation breaks in the lead wires.
4. If no visual problems indicated, carefully remove the leads at the compressor terminals.
Carefully retest for ground, directly between compressor terminals and ground.
5. If ground is indicated, replace the compressor.

SERVICING

S-17D OPERATION TEST

If the voltage, capacitor, overload and motor winding test fail to show the cause for failure:

 **WARNING**



HIGH VOLTAGE!
DISCONNECT ALL POWER BEFORE SERVICING OR INSTALLING THIS UNIT. MULTIPLE POWER SOURCES MAY BE PRESENT. FAILURE TO DO SO MAY CAUSE PROPERTY DAMAGE, PERSONAL INJURY OR DEATH.

1. Remove unit wiring from disconnect switch and wire a test cord to the disconnect switch.

NOTE: The wire size of the test cord must equal the line wire size and the fuse must be of the proper size and type.

2. With the protective terminal cover in place, use the three leads to the compressor terminals that were disconnected at the nearest point to the compressor and connect the common, start and run clips to the respective leads.
3. Connect good capacitors of the right MFD and voltage rating into the circuit.
4. With power ON, close the switch.

 **WARNING**

LINE VOLTAGE NOW PRESENT.

- A. If the compressor starts and continues to run, the cause for failure is somewhere else in the system.
- B. If the compressor fails to start - replace.

S-18 TESTING CRANKCASE HEATER

Note: Not all compressors use crankcase heaters.

The crankcase heater must be energized a minimum of twenty-four (24) hours before the compressor is operated.

Crankcase heaters are used to prevent migration or accumulation of refrigerant in the compressor crankcase during the off cycles and prevents liquid slugging or oil pumping on start up. On some models, the crankcase heater is controlled by a crankcase heater thermostat that is wired in series with the crankcase heater.

A crankcase heater will not prevent compressor damage due to a floodback or over charge condition.

 **WARNING**

DISCONNECT POWER SUPPLY BEFORE SERVICING.

1. Disconnect the heater lead wires.
2. Using an ohmmeter, check heater continuity - should test continuous, if not, replace.

S-18A CHECKING CRANKCASE HEATER THERMOSTAT

Note: Not all models with crankcase heaters will have a crankcase heater thermostat.

1. Install a thermocouple type temperature test lead on the discharge line adjacent to the crankcase heater thermostat.
2. Check the temperature at which the control closes its contacts by lowering the temperature of the control. The crankcase heater thermostat should close at $67^{\circ}\text{F} \pm 5^{\circ}\text{F}$.
3. Check the temperature at which the control opens its contacts by raising the temperature of the control. The crankcase heater thermostat should open at $85^{\circ}\text{F} \pm 5^{\circ}\text{F}$.
4. If not as above, replace control.

S-21 CHECKING REVERSING VALVE AND SOLENOID

Occasionally the reversing valve may stick in the heating or cooling position or in the mid-position.

When stuck in the mid-position, part of the discharge gas from the compressor is directed back to the suction side, resulting in excessively high suction pressure. An increase in the suction line temperature through the reversing valve can also be measured. Check operation of the valve by starting the system and switching the operation from COOLING to HEATING cycle.

If the valve fails to change its position, test the voltage (24V) at the valve coil terminals, while the system is on the COOLING cycle.

If no voltage is registered at the coil terminals, check the operation of the thermostat and the continuity of the connecting wiring from the "O" terminal of the thermostat to the unit.

If voltage is registered at the coil, tap the valve body lightly while switching the system from HEATING to COOLING, etc. If this fails to cause the valve to switch positions, remove the coil connector cap and test the continuity of the reversing valve solenoid coil. If the coil does not test continuous - replace it.

If the coil test continuous and 24 volts is present at the coil terminals, the valve is inoperative - replace it.

SERVICING

S-24 TESTING DEFROST CONTROL

NOTE: PCBDM133 defrost control has a three (3) minute compressor off cycle delay.

NOTE: The PCBDM133 defrost control is shipped from the factory with the compressor delay option selected. This will de-energize the compressor contactor for 30 seconds on defrost initiation and defrost termination. If the jumper is set to Normal, the compressor will continue to run during defrost initiation and defrost termination. The control will also ignore the low pressure switch connected to R-PS1 and PS2 for 5 minutes upon defrost initiation and 5 minutes after defrost termination.

To check the defrost control for proper sequencing, proceed as follows: With power ON; unit not running.

1. Jumper defrost thermostat by placing a jumper wire across the terminals "DFT" and "R-DFT" at defrost control board.
2. Connect jumper across test pins on defrost control board.
3. Set thermostat to call for heating. System should go into defrost within 21 seconds.
4. Immediately remove jumper from test pins.
5. Using VOM check for voltage across terminals "C & "O-RV". Meter should read 24 volts.
6. Using VOM check for voltage across fan terminals DF1 and DF2 on the board. You should read line voltage (208-230 VAC) indicating the relay is open in the defrost mode.
7. Using VOM check for voltage across "W" & "C" terminals on the board. You should read 24 volts.
8. If not as above, replace control board.
9. Set thermostat to off position and disconnect power before removing any jumpers or wires.

NOTE: Remove jumper across defrost thermostat before returning system to service.

S-25 TESTING DEFROST THERMOSTAT

1. Install a thermocouple type temperature test lead on the tube adjacent to the defrost control. Insulate the lead point of contact.
2. Check the temperature at which the control closes its contacts by lowering the temperature of the control. The defrost control should close at $34^{\circ}\text{F} \pm 5^{\circ}\text{F}$.
3. Check the temperature at which the control opens its contacts by raising the temperature of the control. The defrost control should open at $60^{\circ}\text{F} \pm 5^{\circ}\text{F}$.
4. If not as above, replace control.

S-50 CHECKING HEATER LIMIT CONTROL(S)

(OPTIONAL ELECTRIC HEATERS)

Each individual heater element is protected with an automatic rest limit control connected in series with each element to prevent overheating of components in case of low airflow. This limit control will open its circuit at approximately 150°F . to 160°F and close at approximately 110°F .



WARNING

DISCONNECT ELECTRICAL POWER SUPPLY.

1. Remove the wiring from the control terminals.
2. Using an ohmmeter test for continuity across the normally closed contacts. No reading indicates the control is open - replace if necessary. Make sure the limits are cool before testing.

IF FOUND OPEN - REPLACE - DO NOT WIRE AROUND.

S-52 CHECKING HEATER ELEMENTS

Optional electric heaters may be added, in the quantities shown in the spec sheet for each model unit, to provide electric resistance heating. Under no condition shall more heaters than the quantity shown be installed.



WARNING

**HIGH VOLTAGE!
DISCONNECT ALL POWER BEFORE
SERVICING OR INSTALLING THIS UNIT.
MULTIPLE POWER SOURCES MAY BE
PRESENT. FAILURE TO DO SO MAY CAUSE PROPERTY
DAMAGE, PERSONAL INJURY OR DEATH.**



1. Disassemble and remove the heating element(s).
2. Visually inspect the heater assembly for any breaks in the wire or broken insulators.
3. Using an ohmmeter, test the element for continuity - no reading indicates the element is open. Replace as necessary.

S-100 REFRIGERATION REPAIR PRACTICE



DANGER

**ALWAYS REMOVE THE REFRIGERANT CHARGE IN
A PROPER MANNER BEFORE APPLYING HEAT TO
THE SYSTEM.**

These models use the FasTest Access Fitting System, with a saddle that is either soldered to the suction and liquid lines or is fastened with a locking nut to the access fitting box (core) and then screwed into the saddle. **Do not remove the core from the saddle until the refrigerant charge has been removed. Failure to do so could result in property damage or personal injury.**

When installing a new core or reinstalling the core after removal, it is very important to note that before inserting the core into the saddle, the core and saddle must be free of debris and the "O" Ring **must** have a thin coating of refrigerant oil applied to it. The oil is to prevent the "O" Ring from being deformed

SERVICING

when the core is tightened completely. The core should be torqued to 8 ft. lb.

When repairing the refrigeration system:

1. Never open a system that is under vacuum. Air and moisture will be drawn in.
2. Plug or cap all openings.
3. Remove all burrs and clean the brazing surfaces of the tubing with sand cloth or paper. Brazing materials do not flow well on oxidized or oily surfaces.
4. Clean the inside of all new tubing to remove oils and pipe chips.
5. When brazing, sweep the tubing with dry nitrogen to prevent the formation of oxides on the inside surfaces.
6. Complete any repair by replacing the liquid line drier in the system, evacuate and charge.

At any time the system has been open for repair, the factory installed liquid line filter drier **must** be replaced.

BRAZING MATERIALS

Copper to Copper Joints - Sil-Fos used without flux (alloy of 15% silver, 80% copper, and 5% phosphorous). Recommended heat 1400°F.

Copper to Steel Joints - Silver Solder used without a flux (alloy of 30% silver, 38% copper, 32% zinc). Recommended heat - 1200°F.

S-101 LEAK TESTING (NITROGEN OR NITROGEN-TRACED)



TO AVOID THE RISK OF FIRE OR EXPLOSION, NEVER USE OXYGEN, HIGH PRESSURE AIR OR FLAMMABLE GASES FOR LEAK TESTING OF A REFRIGERATION SYSTEM.



TO AVOID POSSIBLE EXPLOSION, THE LINE FROM THE NITROGEN CYLINDER MUST INCLUDE A PRESSURE REGULATOR AND A PRESSURE RELIEF VALVE. THE PRESSURE RELIEF VALVE MUST BE SET TO OPEN AT NO MORE THAN 150 psig.

Pressure test the system using dry nitrogen and soapy water to locate leaks. If you wish to use a leak detector, charge the system to 10 psi using the appropriate refrigerant then use nitrogen to finish charging the system to working pressure, then apply the detector to suspect areas. If leaks are found, repair them. After repair, repeat the pressure test. If no leaks exist, proceed to system evacuation.

S-102 EVACUATION



**REFRIGERANT UNDER PRESSURE!
FAILURE TO FOLLOW PROPER PROCEDURES MAY
CAUSE PROPERTY DAMAGE, PERSONAL INJURY OR
DEATH.**

This is the most important part of the entire service procedure. The life and efficiency of the equipment is dependent upon the thoroughness exercised by the serviceman when evacuating air (non-condensable) and moisture from the system.

Air in a system causes high condensing temperature and pressure, resulting in increased power input and reduced performance.

Moisture chemically reacts with the refrigerant and oil to form corrosive hydrofluoric and hydrochloric acids. These attack motor windings and parts, causing breakdown.

The equipment required to thoroughly evacuate the system is a high vacuum pump, capable of producing a vacuum equivalent to 25 microns absolute and a thermocouple vacuum gauge to give a true reading of the vacuum in the system

NOTE: Never use the system compressor as a vacuum pump or run when under a high vacuum. Motor damage could occur.



**SCROLL COMPRESSORS
DO NOT FRONT SEAT THE SERVICE VALVE(S) WITH
THE COMPRESSOR OPERATING IN AN ATTEMPT TO
SAVE REFRIGERANT. WITH THE SUCTION LINE OF
THE COMPRESSOR CLOSED OR SEVERLY RESTRICTED,
THE SCROLL COMPRESSOR WILL DRAW A DEEP
VACUUM VERY QUICKLY. THIS VACUUM CAN CAUSE
INTERNAL ARCING OF THE FUSITE RESULTING IN A
DAMAGED OR FAILED COMPRESSOR.**

1. Connect the vacuum pump, vacuum tight manifold set with high vacuum hoses, thermocouple vacuum gauge and charging cylinder as shown.

SERVICING

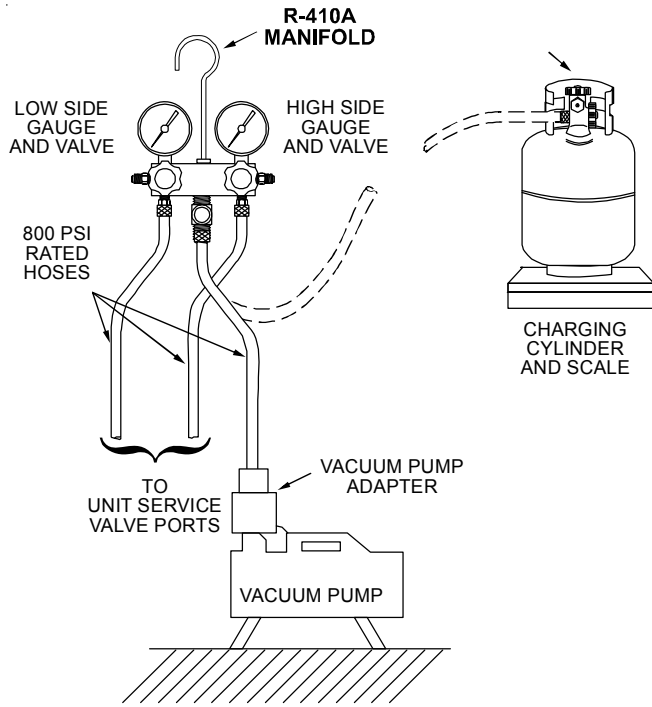

2. Start the vacuum pump and open the shut off valve to the high vacuum gauge manifold only. After the compound gauge (low side) has dropped to approximately 29 inches of vacuum, open the valve to the vacuum thermocouple gauge. See that the vacuum pump will blank-off to a maximum of 25 microns. A high vacuum pump can only produce a good vacuum if its oil is non-contaminated.
3. If the vacuum pump is working properly, close the valve to the vacuum thermocouple gauge and open the high and low side valves to the high vacuum manifold set. With the valve on the charging cylinder closed, open the manifold valve to the cylinder.
4. Evacuate the system to at least 29 inches gauge before opening valve to thermocouple vacuum gauge.
5. Continue to evacuate to a minimum of 250 microns. Close valve to vacuum pump and watch rate of rise. If vacuum does not rise above 1500 microns in three to five minutes, system can be considered properly evacuated.
6. If thermocouple vacuum gauge continues to rise and levels off at about 5000 microns, moisture and non-condensables are still present. If gauge continues to rise a leak is present. Repair and re-evacuate.
7. Close valve to thermocouple vacuum gauge and vacuum pump. Shut off pump and prepare to charge.

S-103 CHARGING



WARNING

REFRIGERANT UNDER PRESSURE!

* DO NOT OVERCHARGE SYSTEM WITH REFRIGERANT.
 * DO NOT OPERATE UNIT IN A VACUUM OR AT NEGATIVE PRESSURE.
 FAILURE TO FOLLOW PROPER PROCEDURES MAY CAUSE PROPERTY DAMAGE, PERSONAL INJURY OR DEATH.



CAUTION

ONLY USE REFRIGERANT CERTIFIED TO AHRI STANDARDS. USED REFRIGERANT MAY CAUSE COMPRESSOR DAMAGE. GOODMAN IS NOT RESPONSIBLE FOR DAMAGE OR THE NEED FOR REPAIRS RESULTING FROM THE USE OF UNAPPROVED REFRIGERANT TYPES OR USED OR RECYCLED REFRIGERANT. MOST PORTABLE MACHINES CANNOT CLEAN USED REFRIGERANT TO MEET AHRI STANDARDS.

Charge the system with the exact amount of refrigerant.

Refer to the specification section or check the unit nameplates for the correct refrigerant charge.

An inaccurately charged system will cause future problems.

1. Using a calibrated set of refrigerant scales, allow liquid refrigerant only to enter the high side.
2. After the system will take all it will take, close the valve on the high side of the charging manifold.
3. Start the system and charge the balance of the refrigerant through the low side.

NOTE: R410A should be drawn out of the storage container or drum in liquid form due to its fractionation properties, but should be "Flashed" to its gas state before entering the system. There are commercially available restriction devices that fit into the system charging hose set to accomplish this. **DO NOT** charge liquid R410A into the compressor.

4. With the system still running, close the valve on the charging cylinder. At this time, you may still have some liquid refrigerant in the charging cylinder hose and will definitely have liquid in the liquid hose. Reseat the liquid line core. Slowly open the high side manifold valve and transfer the liquid refrigerant from the liquid line hose and charging cylinder hose into the suction service valve port. **CAREFUL:** Watch so that liquid refrigerant does not enter the compressor.

Final Charge Adjustment

The outdoor temperature must be 60°F or higher. Set the room thermostat to COOL, fan switch to AUTO, and set the temperature control well below room temperature.

After system has stabilized per startup instructions, compare the operating pressures and outdoor unit amp draw to the numbers listed in the technical manual. If pressures and amp draw are too low, add charge. If pressures and amp draw are too high, remove charge. Check subcooling and superheat as detailed in the following section.

5. With the system still running, remove hose and reinstall both valve caps.
6. Check system for leaks.

Due to their design, Scroll compressors are inherently more tolerant of liquid refrigerant.

NOTE: Even though the compressor section of a Scroll compressor is more tolerant of liquid refrigerant, continued flood-back or flooded start conditions may wash oil from the bearing surfaces causing premature bearing failure.

SERVICING

S-104 CHECKING COMPRESSOR EFFICIENCY

The reason for compressor inefficiency is broken or damaged suction and/or discharge valves, or scroll flanks on Scroll compressors, reducing the ability of the compressor to pump refrigerant vapor.

The condition of the valves or scroll flanks is checked in the following manner.

1. Attach gauges to the high and low side of the system.
2. Start the system and run a Cooling Performance Test.

If the test shows-

- ⇒ Below normal high side pressure.
- ⇒ Above normal low side pressure.
- ⇒ Low temperature difference across coil.
- ⇒ Low amp draw at compressor.

-and the charge is correct. The compressor is faulty - replace the compressor.

S-105 THERMOSTATIC EXPANSION VALVE

The expansion valve is designed to control the rate of liquid refrigerant flow into an evaporator coil in exact proportion to the rate of evaporation of the refrigerant in the coil. The amount of refrigerant entering the coil is regulated since the valve responds to temperature of the refrigerant gas leaving the coil (feeler bulb contact) and the pressure of the refrigerant in the coil. This regulation of the flow prevents the return of liquid refrigerant to the compressor.

The illustration below shows typical heatpump TXV/check valve operation in the heating and cooling modes.

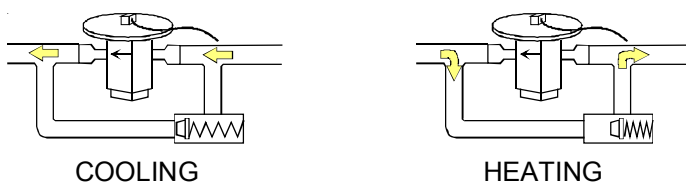

TXV VALVES

Some TXV valves contain an internal check valve thus eliminating the need for an external check valve and bypass loop. The three forces which govern the operation of the valve are: (1) the pressure created in the power assembly by the feeler bulb, (2) evaporator pressure, and (3) the equivalent pressure of the superheat spring in the valve.

0% bleed type expansion valves are used on indoor and outdoor coils. The 0% bleed valve will not allow the system pressures (High and Low side) to equalize during the shut down period. The valve will shut off completely at approximately 100 PSIG.

30% bleed valves used on some other models will continue to allow some equalization even though the valve has shut-off completely because of the bleed holes within the valve. This type of valve should not be used as a replacement for a 0% bleed valve, due to the resulting drop in performance.

The bulb must be securely fastened with two straps to a clean straight section of the suction line. Application of the bulb to a horizontal run of line is preferred. If a vertical installation cannot be avoided, the bulb must be mounted so that the capillary tubing comes out at the top.

THE VALVES PROVIDED BY GOODMAN ARE DESIGNED TO MEET THE SPECIFICATION REQUIREMENTS FOR OPTIMUM PRODUCT OPERATION. DO NOT USE SUBSTITUTES.

S-106 OVERFEEDING

Overfeeding by the expansion valve results in high suction pressure, cold suction line, and possible liquid slugging of the compressor.

If these symptoms are observed:

1. Check for an overcharged unit by referring to the cooling performance charts in the servicing section.
2. Check the operation of the power element in the valve as explained in S-110 Checking Expansion Valve Operation.
3. Check for restricted or plugged equalizer tube.

S-107 UNDERFEEDING

Underfeeding by the expansion valve results in low system capacity and low suction pressures.

If these symptoms are observed:

1. Check for a restricted liquid line or drier. A restriction will be indicated by a temperature drop across the drier.
2. Check the operation of the power element of the valve as described in S-110 Checking Expansion Valve Operation.

S-108 SUPERHEAT

The expansion valves are factory adjusted to maintain 15 to 18 degrees superheat of the suction gas. Before checking the superheat or replacing the valve, perform all the procedures outlined under Air Flow, Refrigerant Charge, Expansion Valve - Overfeeding, Underfeeding. These are the most common causes for evaporator malfunction.

CHECKING SUPERHEAT

Refrigerant gas is considered superheated when its temperature is higher than the saturation temperature corresponding to its pressure. The degree of superheat equals the degrees of temperature increase above the saturation temperature at existing pressure. See Temperature - Pressure Chart on following pages.

S-109 CHECKING SUBCOOLING

Refrigerant liquid is considered subcooled when its temperature is lower than the saturation temperature corresponding to its pressure. The degree of subcooling equals the degrees of temperature decrease below the saturation temperature at the existing pressure.

Wiring is subject to change. Always refer to the wiring diagram on the unit for the most up-to-date wiring.

SERVICING

1. Attach an accurate thermometer or preferably a thermocouple type temperature tester to the liquid line close to the high pressure access fitting process tube.
2. Install a high side pressure gauge on the high side (liquid) access fitting.
3. Record the gauge pressure and the temperature of the line.
4. Review the technical information manual or specification sheet for the model being serviced to obtain the design subcooling.
5. Compare the hi-pressure reading to the "Required Liquid Line Temperature" chart. Find the hi-pressure value on the left column. Follow that line right to the column under the design subcooling value. Where the two intersect is the required liquid line temperature.

Alternately you can convert the liquid line pressure gauge reading to temperature by finding the gauge reading in Temperature - Pressure Chart and reading to the left, find the temperature in the °F. Column.

6. The difference between the thermometer reading and pressure to temperature conversion is the amount of subcooling.

Add charge to raise subcooling. Recover charge to lower subcooling.

SUBCOOLING = SAT. LIQUID TEMP. - LIQUID LINE TEMP.

EXAMPLE:

- a. Liquid Line Pressure = 417
- b. Corresponding Temp. °F. = 120°
- c. Thermometer on Liquid line = 113°F.

To obtain the amount of subcooling subtract 113°F from 120°F.

The difference is 7° subcooling, which would fall in the ± range of allowable subcooling.

S-110 CHECKING EXPANSION VALVE OPERATION

1. Remove the remote bulb of the expansion valve from the suction line.
2. Start the system and cool the bulb in a container of ice water, closing the valve. As you cool the bulb, the suction pressure should fall and the suction temperature will rise.
3. Next warm the bulb in your hand. As you warm the bulb, the suction pressure should rise and the suction temperature will fall.
4. If a temperature or pressure change is noticed, the expansion valve is operating. If no change is noticed, the valve is restricted, the power element is faulty, or the equalizer tube is plugged.
5. Capture the charge, replace the valve and drier, evacuate and recharge.

SUPERHEAT AND SUBCOOLING ADJUSTMENT ON TXV APPLICATIONS

EXPANSION VALVE (TXV) SYSTEM

Two Speed Application (APH16)

Run the unit on high stage cooling for 10 minutes until refrigerant pressures stabilize. Follow the guidelines and methods below to check unit operation and ensure that the refrigerant charge is within limits. Charge the unit on high stage.

1. Purge gauge lines. Connect service gauge manifold to access fittings. Run system at least 10 minutes to allow pressure to stabilize.
2. Temporarily install thermometer on liquid (small) line near liquid line access fitting with adequate contact and insulate for best possible reading.
3. Check subcooling and superheat. Two stage systems running on high stage with TXV application should have a subcooling and superheat within the range listed on the chart.
 - a. If subcooling and superheat are low, **adjust TXV** superheat, then check subcooling.

SATURATED SUCTION PRESSURE TEMPERATURE CHART	
SUCTION PRESSURE	SATURATED SUCTION TEMPERATURE °F
PSIG	R-410A
50	1
52	3
54	4
56	6
58	7
60	8
62	10
64	11
66	13
68	14
70	15
72	16
74	17
76	19
78	20
80	21
85	24
90	26
95	29
100	31
110	36
120	41
130	45
140	49
150	53
160	56
170	60

SERVICING

Pressure vs. Temperature Chart													
R-410A													
PSIG	°F	PSIG	°F	PSIG	°F	PSIG	°F	PSIG	°F	PSIG	°F	PSIG	°F
12	-37.7	114.0	37.8	216.0	74.3	318.0	100.2	420.0	120.7	522.0	137.6		
14	-34.7	116.0	38.7	218.0	74.9	320.0	100.7	422.0	121.0	524.0	137.9		
16	-32.0	118.0	39.5	220.0	75.5	322.0	101.1	424.0	121.4	526.0	138.3		
18	-29.4	120.0	40.5	222.0	76.1	324.0	101.6	426.0	121.7	528.0	138.6		
20	-36.9	122.0	41.3	224.0	76.7	326.0	102.0	428.0	122.1	530.0	138.9		
22	-24.5	124.0	42.2	226.0	77.2	328.0	102.4	430.0	122.5	532.0	139.2		
24	-22.2	126.0	43.0	228.0	77.8	330.0	102.9	432.0	122.8	534.0	139.5		
26	-20.0	128.0	43.8	230.0	78.4	332.0	103.3	434.0	123.2	536.0	139.8		
28	-17.9	130.0	44.7	232.0	78.9	334.0	103.7	436.0	123.5	538.0	140.1		
30	-15.8	132.0	45.5	234.0	79.5	336.0	104.2	438.0	123.9	540.0	140.4		
32	-13.8	134.0	46.3	236.0	80.0	338.0	104.6	440.0	124.2	544.0	141.0		
34	-11.9	136.0	47.1	238.0	80.6	340.0	105.1	442.0	124.6	548.0	141.6		
36	-10.1	138.0	47.9	240.0	81.1	342.0	105.4	444.0	124.9	552.0	142.1		
38	-8.3	140.0	48.7	242.0	81.6	344.0	105.8	446.0	125.3	556.0	142.7		
40	-6.5	142.0	49.5	244.0	82.2	346.0	106.3	448.0	125.6	560.0	143.3		
42	-4.5	144.0	50.3	246.0	82.7	348.0	106.6	450.0	126.0	564.0	143.9		
44	-3.2	146.0	51.1	248.0	83.3	350.0	107.1	452.0	126.3	568.0	144.5		
46	-1.6	148.0	51.8	250.0	83.8	352.0	107.5	454.0	126.6	572.0	145.0		
48	0.0	150.0	52.5	252.0	84.3	354.0	107.9	456.0	127.0	576.0	145.6		
50	1.5	152.0	53.3	254.0	84.8	356.0	108.3	458.0	127.3	580.0	146.2		
52	3.0	154.0	54.0	256.0	85.4	358.0	108.8	460.0	127.7	584.0	146.7		
54	4.5	156.0	54.8	258.0	85.9	360.0	109.2	462.0	128.0	588.0	147.3		
56	5.9	158.0	55.5	260.0	86.4	362.0	109.6	464.0	128.3	592.0	147.9		
58	7.3	160.0	56.2	262.0	86.9	364.0	110.0	466.0	128.7	596.0	148.4		
60	8.6	162.0	57.0	264.0	87.4	366.0	110.4	468.0	129.0	600.0	149.0		
62	10.0	164.0	57.7	266.0	87.9	368.0	110.8	470.0	129.3	604.0	149.5		
64	11.3	166.0	58.4	268.0	88.4	370.0	111.2	472.0	129.7	608.0	150.1		
66	12.6	168.0	59.0	270.0	88.9	372.0	111.6	474.0	130.0	612.0	150.6		
68	13.8	170.0	59.8	272.0	89.4	374.0	112.0	476.0	130.3	616.0	151.2		
70	15.1	172.0	60.5	274.0	89.9	376.0	112.4	478.0	130.7	620.0	151.7		
72	16.3	174.0	61.1	276.0	90.4	378.0	112.6	480.0	131.0	624.0	152.3		
74	17.5	176.0	61.8	278.0	90.9	380.0	113.1	482.0	131.3	628.0	152.8		
76	18.7	178.0	62.5	280.0	91.4	382.0	113.5	484.0	131.6	632.0	153.4		
78	19.8	180.0	63.1	282.0	91.9	384.0	113.9	486.0	132.0	636.0	153.9		
80	21.0	182.0	63.8	284.0	92.4	386.0	114.3	488.0	132.3	640.0	154.5		
82	22.1	184.0	64.5	286.0	92.8	388.0	114.7	490.0	132.6	644.0	155.0		
84	23.2	186.0	65.1	288.0	93.3	390.0	115.0	492.0	132.9	648.0	155.5		
86	24.3	188.0	65.8	290.0	93.8	392.0	115.5	494.0	133.3	652.0	156.1		
88	25.4	190.0	66.4	292.0	94.3	394.0	115.8	496.0	133.6	656.0	156.6		
90	26.4	192.0	67.0	294.0	94.8	396.0	116.2	498.0	133.9	660.0	157.1		
92	27.4	194.0	67.7	296.0	95.2	398.0	116.6	500.0	134.0	664.0	157.7		
94	28.5	196.0	68.3	298.0	95.7	400.0	117.0	502.0	134.5	668.0	158.2		
96	29.5	198.0	68.9	300.0	96.2	402.0	117.3	504.0	134.8	672.0	158.7		
98	30.5	200.0	69.5	302.0	96.6	404.0	117.7	506.0	135.2	676.0	159.2		
100	31.2	202.0	70.1	304.0	97.1	406.0	118.1	508.0	135.5	680.0	159.8		
102	32.2	204.0	70.7	306.0	97.5	408.0	118.5	510.0	135.8	684.0	160.3		
104	33.2	206.0	71.4	308.0	98.0	410.0	118.8	512.0	136.1	688.0	160.8		
106	34.1	208.0	72.0	310.0	98.4	412.0	119.2	514.0	136.4	692.0	161.3		
108	35.1	210.0	72.6	312.0	98.9	414.0	119.6	516.0	136.7	696.0	161.8		
110	35.5	212.0	73.2	314.0	99.3	416.0	119.9	518.0	137.0				
112	36.9	214.0	73.8	316.0	99.7	418.0	120.3	520.0	137.3				

*Based on ALLIED SIGNAL Data

Wiring is subject to change. Always refer to the wiring diagram on the unit for the most up-to-date wiring.

SERVICING

REQUIRED LIQUID LINE TEMPERATURE						
LIQUID PRESSURE AT SERVICE VALVE (PSIG)	REQUIRED SUBCOOLING TEMPERATURE (°F)					
	8	10	12	14	16	18
189	58	56	54	52	50	48
195	60	58	56	54	52	50
202	62	60	58	56	54	52
208	64	62	60	58	56	54
215	66	64	62	60	58	56
222	68	66	64	62	60	58
229	70	68	66	64	62	60
236	72	70	68	66	64	62
243	74	72	70	68	66	64
251	76	74	72	70	68	66
259	78	76	74	72	70	68
266	80	78	76	74	72	70
274	82	80	78	76	74	72
283	84	82	80	78	76	74
291	86	84	82	80	78	76
299	88	86	84	82	80	78
308	90	88	86	84	82	80
317	92	90	88	86	84	82
326	94	92	90	88	86	84
335	96	94	92	90	88	86
345	98	96	94	92	90	88
354	100	98	96	94	92	90
364	102	100	98	96	94	92
374	104	102	100	98	96	94
384	106	104	102	100	98	96
395	108	106	104	102	100	98
406	110	108	106	104	102	100
416	112	110	108	106	104	102
427	114	112	110	108	106	104
439	116	114	112	110	108	106
450	118	116	114	112	110	108
462	120	118	116	114	112	110
474	122	120	118	116	114	112
486	124	122	120	118	116	114
499	126	124	122	120	118	116
511	128	126	124	122	120	118

SERVICING

NOTE: To adjust superheat, turn the valve stem clockwise to increase and counter clockwise to decrease.

- b. If subcooling is low and superheat is high, **add** charge to raise subcooling then check superheat.
- c. If subcooling and superheat are high, **adjust** TXV valve superheat, then check subcooling.
- d. If subcooling is high and superheat is low, **adjust** TXV valve superheat and **remove** charge to lower the subcooling.

NOTE: Do **NOT** adjust the charge based on suction pressure unless there is a gross undercharge.

- 4. Disconnect manifold set, installation is complete.

Refrigerant Charge Check (Units with Fixed Orifice Devices)

After completing airflow measurements and adjustments the unit's refrigerant charge must be checked. All package units with fixed orifice devices are charged using the super heat method at the compressor suction line.

After superheat is adjusted it is recommended to check unit sub-cooling at the condenser coil liquid line out. For charge adjustments, see superheat and subcooling charts shown for each model.

Measure the hot gas discharge at the compressor to ensure proper TXV setting. To ensure optimum system performance in heat mode, the TXV may require adjustment.

- 1. Allow the system to operate for at least 20 minutes.
- 2. Attach and insulate an electronic thermometer to the hot gas discharge line mid-way between the compressor and the reversing valve.

NOTE: The thermometer must be well insulated to prevent ambient influences.

- 3. Allow the compressor to operate for about 10 additional minutes and measure the hot gas discharge temperature.
- 4. Using an additional electronic thermometer, measure the ambient temperature.
- 5. Adjust the TXV until the hot gas temperature equals 100°F + ambient temperature (+ or - 3°F). Close TXV to increase the temperature.

NOTE: When adjusting the TXV, allow the compressor to operate for about 10 minutes before taking readings. Do not adjust TXV more than 1/4 of a turn between readings.

SUPERHEAT=SUCTION LINE TEMP-SUCTION TEMP

Design Superheat & Subcooling @ 95 °F Outdoor Ambient Temperature High Stage		
Models	Superheat °F	Subcooling °F
A/GPH1624M41	15 ±2	8 ±2
A/GPH1630M41	15 ±2	10 ±2
A/GPH1636M41	13 ±2	10 ±2
A/GPH1642M41	15 ±2	10 ±2
A/GPH1648M41	15 ±2	13 ±2
A/GPH1660M41	14 ±2	11 ±2



TO PREVENT PERSONAL INJURY, CAREFULLY CONNECT AND DISCONNECT MANIFOLD GAUGE HOSES. ESCAPING LIQUID REFRIGERANT CAN CAUSE BURNS. DO NOT VENT REFRIGERANT TO ATMOSPHERE. RECOVER DURING SYSTEM REPAIR OR FINAL UNIT DISPOSAL.

SYSTEM CHARGING HEATING MODE

The proper method of charging a heat pump in the heat mode is by weighing the charge according to the total charge listed on the rating plate.

Wiring is subject to change. Always refer to the wiring diagram on the unit for the most up-to-date wiring.

SERVICING

SUBCOOLING = SAT. LIQUID TEMP. - LIQUID LINE TEMP.

SATURATED LIQUID PRESSURE TEMPERATURE CHART	
Liquid Pressure	Saturated Liquid Temperature °F
PSIG	R-410A
200	70
210	73
220	76
225	78
235	80
245	83
255	85
265	88
275	90
285	92
295	95
305	97
325	101
355	108
375	112
405	118

SUBCOOLING = SAT. LIQUID TEMP. - LIQUID LINE TEMP.

Heat Pump - Heating Cycle

The proper method of charging a heat pump in the heat mode is by weighing the charge according to the total charge listed on the rating plate.

S-112 CHECKING RESTRICTED LIQUID LINE

When the system is operating, the liquid line is warm to the touch. If the liquid line is restricted, a definite temperature drop will be noticed at the point of restriction. In severe cases, frost will form at the restriction and extend down the line in the direction of the flow.

Discharge and suction pressures will be low, giving the appearance of an undercharged unit. However, the unit will have normal to high subcooling.

If a restriction is located, replace the restricted part, replace drier, evacuate and recharge.

S-113 REFRIGERANT OVERCHARGE

An overcharge of refrigerant is normally indicated by excessively high head pressure and/or liquid refrigerant return to the compressor.

If high head pressure is not indicated, an overcharge or a system containing non-condensables could be the problem.

If overcharging is indicated:

1. Start the system.
2. Remove small quantities of gas from the suction line dill valve until the head pressure is reduced to normal.

3. Observe the system while running a cooling performance test, if a shortage of refrigerant is indicated, then the system contains non-condensables. See S-114 Non-Condensables.

S-114 NON-CONDENSABLES

Check for non-condensables.

1. Shut down the system and allow the pressures to equalize for a minimum of 15 minutes.
2. Take a pressure reading.
3. Compare this pressure to the temperature of the coldest coil since this is where most of the refrigerant will be. If the pressure indicates a higher temperature than that of the coil temperature, non-condensables are present.

To remove the non-condensables.

1. Remove the refrigerant charge.
2. Replace and/or install liquid line drier
3. Evacuate and recharge.

S-115 COMPRESSOR BURNOUT

When a compressor burns out, high temperature develops causing the refrigerant, oil and motor insulation to decompose forming acids and sludge.

If a compressor is suspected of being burned-out, attach a refrigerant hose to the liquid line dill valve and properly remove and dispose of the refrigerant.



VIOLATION OF EPA REGULATIONS MAY RESULT IN FINES OR OTHER PENALTIES.

Now determine if a burn out has actually occurred. Confirm by analyzing an oil sample using a Sporlan Acid Test Kit, AK-3 or its equivalent.

Remove the compressor and obtain an oil sample from the suction stub. If the oil is not acidic, either a burnout has not occurred or the burnout is so mild that a complete clean-up is not necessary.

If acid level is unacceptable, the system must be cleaned by using the clean-up drier method.



DO NOT ALLOW THE SLUDGE OR OIL TO CONTACT THE SKIN, SEVERE BURNS MAY RESULT.

NOTE: The Flushing Method using R-11 refrigerant is no longer approved by Goodman® Manufacturing Company, L.P.

Suction Line Drier Clean-Up Method

The POE oils used with R410A refrigerant is an excellent solvent. In the case of a burnout, the POE oils will remove any burnout residue left in the system. If not captured by the refrigerant filter, they will collect in the compressor or other system

SERVICING

components, causing a failure of the replacement compressor and/or spread contaminants throughout the system, damaging additional components.

Use AMANA® brand part number RF000127 suction line filter drier kit. This drier should be installed as close to the compressor suction fitting as possible. The filter must be accessible and be rechecked for a pressure drop after the system has operated for a time. It may be necessary to use new tubing and form as required.

NOTE: At least twelve (12) inches of the suction line immediately out of the compressor stub must be discarded due to burned residue and contaminants.

1. Remove compressor discharge line strainer.
2. Remove the liquid line drier and expansion valve.
3. Purge all remaining components with dry nitrogen or carbon dioxide until clean.
4. Install new components **including** liquid line drier.
5. Braze all joints, leak test, evacuate, and recharge system.
6. Start up the unit and record the pressure drop across the drier.
7. Continue to run the system for a minimum of twelve (12) hours and recheck the pressure drop across the drier. Pressure drop should not exceed 6 PSIG.
8. Continue to run the system for several days, repeatedly checking pressure drop across the suction line drier. If the pressure drop never exceeds the 6 PSIG, the drier has trapped the contaminants. Remove the suction line drier from the system.
9. If the pressure drop becomes greater, then it must be replaced and steps 5 through 9 repeated until it does not exceed 6 PSIG.

NOTICE: Regardless, the cause for burnout must be determined and corrected before the new compressor is started.

S-122 REVERSING VALVE REPLACEMENT

Remove the refrigerant charge from the system.

When brazing a reversing valve into the system, it is of extreme importance that the temperature of the valve **does not exceed 250°F.** at any time.

Wrap the reversing valve with a large rag saturated with water. "Re-wet" the rag and thoroughly cool the valve after each brazing operation of the four joints involved. The wet rag around the reversing valve will eliminate conduction of heat to the valve body when brazing the line connection.

The use of a wet rag sometimes can be a nuisance. There are commercial grades of heat absorbing paste that may be substituted.

After the valve has been installed, leak test, evacuate and recharge.

S-200 CHECKING EXTERNAL STATIC PRESSURE

The minimum and maximum allowable duct static pressure is found in the Technical Information Manual.

Too great of an external static pressure will result in insufficient air that can cause icing of the coil, whereas too much air can cause poor humidity control, and condensate to be pulled off the evaporator coil causing condensate leakage. Too much air can cause motor overloading and in many cases this constitutes a poorly designed system. To determine proper air movement, proceed as follows:

1. Using a draft gauge (inclined manometer) measure the static pressure of the return duct at the inlet of the unit, (Negative Pressure).

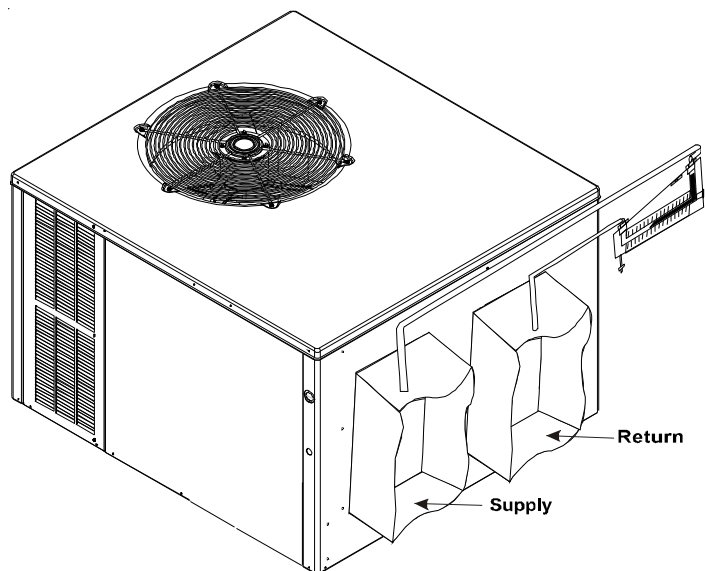

Total External Static

2. Measure the static pressure of the supply duct, (Positive Pressure).
3. Add the two readings together.

NOTE: Both readings may be taken simultaneously and read directly on the manometer as shown in the illustration above, if so desired.

4. Consult proper table for quantity of air.

If the external static pressure exceeds the minimum or maximum allowable statics, check for closed dampers, dirty filters, undersized or poorly laid out ductwork.

SERVICING

S-201 CHECKING TEMPERATURE RISE

Temperature rise is related to the BTUH output of the unit and the amount of air (CFM) circulated over the indoor coil.

All units are designed for a given range of temperature increase. This is the temperature of the air leaving the unit minus the temperature of the air entering the unit.

The more air (CFM) being delivered through a given unit the less the rise will be; so the less air (CFM) being delivered, the greater the rise. The temperature rise should be adjusted in accordance to a given unit specifications and its external static pressure.

1. Take entering and leaving air temperatures.
2. Select the proper speed tap from the unit's blower performance data in the Technical Manual for the specific unit.
3. Take motor amperage draw to determine that the motor is not overloaded during adjustments.

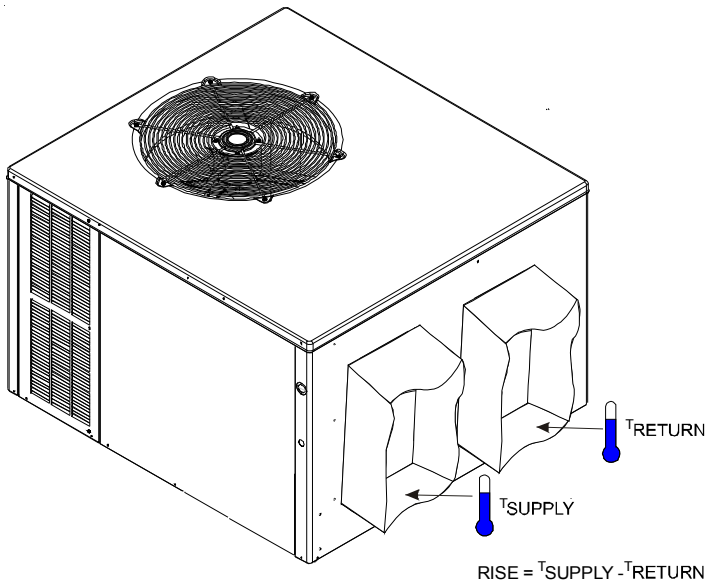

Checking Temperature Rise

AIR FLOW DATA

APH1624M41					
Cooling/HP Speed	Adjust Tap	CFM*	Electric Heat	Adjust Tap	CFM*
D	Minus	630	D	Minus	630
D	Normal	700	D	Normal	700
D	Plus	770	D	Plus	770
C	Minus	743	C	Minus	743
C	Normal	825	C	Normal	825
C	Plus	908	C	Plus	908
B	Minus**	855	B	Minus**	855
B	Normal	950	B	Normal	950
B	Plus	1,045	B	Plus	1,045
A	Minus	945	A	Minus	945
A	Normal	1,050	A	Normal	1,050
A	Plus	1,155	A	Plus	1,155

* @ 0.1 - 0.8 ESP

**FACTORY DEFAULT IS "B" MINUS

APH1630M41					
Cooling/HP Speed	Adjust Tap	CFM*	Electric Heat	Adjust Tap	CFM*
D	Minus	720	D	Minus	720
D	Normal	800	D	Normal	800
D	Plus	880	D	Plus	880
C	Minus	900	C	Minus	900
C	Normal	1,000	C	Normal	1,000
C	Plus	1,100	C	Plus	1,100
B	Minus	990	B	Minus	990
B	Normal**	1,100	B	Normal**	1,100
B	Plus	1,210	B	Plus	1,210
A	Minus	1,125	A	Minus	1,125
A	Normal	1,250	A	Normal	1,250
A	Plus	1,375	A	Plus	1,375

* @ 0.1 - 0.8 ESP

**FACTORY DEFAULT IS "B" NORMAL

APH1636M41					
Cooling/HP Speed	Adjust Tap	CFM*	Electric Heat	Adjust Tap	CFM*
D	Minus	720	D	Minus	720
D	Normal	800	D	Normal	800
D	Plus	880	D	Plus	880
C	Minus	900	C	Minus	900
C	Normal	1,000	C	Normal	1,000
C	Plus	1,100	C	Plus	1,100
B	Minus	990	B	Minus	990
B	Normal**	1,100	B	Normal**	1,100
B	Plus	1,210	B	Plus	1,210
A	Minus	1,125	A	Minus	1,125
A	Normal	1,250	A	Normal	1,250
A	Plus	1,375	A	Plus	1,375

* @ 0.1 - 0.8 ESP

**FACTORY DEFAULT IS "B" NORMAL

APH1642M41					
Cooling/HP Speed	Adjust Tap	CFM*	Electric Heat	Adjust Tap	CFM*
D	Minus	1,103	D	Minus	1,103
D	Normal	1,225	D	Normal	1,225
D	Plus	1,348	D	Plus	1,348
C	Minus**	1,260	C	Minus**	1,260
C	Normal	1,400	C	Normal	1,400
C	Plus	1,540	C	Plus	1,540
B	Minus	1,530	B	Minus	1,530
B	Normal	1,700	B	Normal	1,700
B	Plus	1,870	B	Plus	1,870
A	Minus	1,620	A	Minus	1,620
A	Normal	1,800	A	Normal	1,800
A	Plus	1,980	A	Plus	1,980

* @ 0.1 - 0.8 ESP

** FACTORY DEFAULT IS "C" MINUS

APH1648M41					
Cooling/HP Speed	Adjust Tap	CFM*	Electric Heat	Adjust Tap	CFM*
D	Minus	1,103	D	Minus	1,103
D	Normal	1,225	D	Normal	1,225
D	Plus	1,348	D	Plus	1,348
C	Minus	1,260	C	Minus	1,260
C	Normal	1,400	C	Normal	1,400
C	Plus	1,540	C	Plus	1,540
B	Minus	1,530	B	Minus	1,530
B	Normal	1,700	B	Normal	1,700
B	Plus	1,870	B	Plus	1,870
A	Minus**	1,620	A	Minus**	1,620
A	Normal	1,800	A	Normal	1,800
A	Plus	1,980	A	Plus	1,980

* @ 0.1 - 0.8 ESP

** FACTORY SETTING IS "A" MINUS

APH1660M41					
Cooling/HP Speed	Adjust Tap	CFM*	Electric Heat	Adjust Tap	CFM*
D	Minus	1,215	D	Minus	1,215
D	Normal	1,350	D	Normal	1,350
D	Plus	1,485	D	Plus	1,485
C	Minus	1,440	C	Minus	1,440
C	Normal	1,600	C	Normal	1,600
C	Plus	1,760	C	Plus	1,760
B	Minus	1,665	B	Minus	1,665
B	Normal	1,850	B	Normal	1,850
B	Plus	2,035	B	Plus	2,035
A	Minus	1,800	A	Minus	1,800
A	Normal**	2,000	A	Normal**	2,000
A	Plus**	2,200	A	Plus	2,200

* @ 0.1 - 0.8 ESP

** INDICATES THE FACTORY SETTING

AIR FLOW DATA

MODEL	SPEED TAP	SWITCH 1	SWITCH 2	ELECTRIC HEAT (CFM)
APH1624	A	Off	Off	1050 ^(F)
	B	On	Off	950
	C	Off	On	825
	D	On	On	700
APH1630	A	Off	Off	1250 ^(F)
	B	On	Off	1100
	C	Off	On	1000
	D	On	On	800
APH1636	A	Off	Off	1250 ^(F)
	B	On	Off	1100
	C	Off	On	1000
	D	On	On	800
APH1642	A	Off	Off	1800
	B	On	Off	1700
	C	Off	On	1400 ^(F)
	D	On	On	1225
APH1648	A	Off	Off	1800 ^(F)
	B	On	Off	1700
	C	Off	On	1400
	D	On	On	1225
APH1660	A	Off	Off	2000 ^(F)
	B	On	Off	1850
	C	Off	On	1600
	D	On	On	1350

^(F) Factory Setting

MODEL	SPEED TAP	SWITCH 5	SWITCH 6	COOLING/HP CFM
APH1624	A	Off	Off	1050 ^(F)
	B	On	Off	950
	C	Off	On	825
	D	On	On	700
APH1630	A	Off	Off	1250 ^(F)
	B	On	Off	1100
	C	Off	On	1000
	D	On	On	800
APH1636	A	Off	Off	1250 ^(F)
	B	On	Off	1100
	C	Off	On	1000
	D	On	On	800
APH1642	A	Off	Off	1800
	B	On	Off	1700
	C	Off	On	1400 ^(F)
	D	On	On	1225
APH1648	A	Off	Off	1800 ^(F)
	B	On	Off	1700
	C	Off	On	1400
	D	On	On	1225 ^(F)
APH1660	A	Off	Off	2000 ^(F)
	B	On	Off	1850
	C	Off	On	1600
	D	On	On	1350

^(F) Factory Setting

DIP Switch Settings for Single and Two-Stage Thermostats

MODEL	SWITCH 3	SWITCH 4	THERMOSTAT
APH16**	N/A	ON	Single Stage
	N/A	OFF	Two-Stage

Adjustments Through Dip Switch Combinations 7-8

CFM	SWITCH 7	SWITCH 8
+10%	On	Off
Normal	Off	Off
-10%	Off	On

AIR FLOW DATA

Horizontal Position		Motor sp	Volts	Static								
Model				0.1	0.2	0.3	0.4	0.5	0.6	0.7	0.8	0.9
GPH1624M41*	T1	230	CFM	671	616	567						
			Watts	51	57	72						
	T2/T3	230	CFM	941	872	777	746	614				
			Watts	105	112	113	128	138				
	T4/T5	230	CFM	1347	1315	1256	1194	1152	1096	1051	972	891
			Watts	239	256	265	271	282	286	293	297	305
<hr/>												
Downshot Position		Motor sp	Volts	Static								
Model				0.1	0.2	0.3	0.4	0.5	0.6	0.7	0.8	0.9
GPH1624M41*	T1	230	CFM	699	595	523						
			Watts	57	61	72						
	T2/T3	230	CFM	919	855	782	695	631	578	523		
			Watts	108	117	121	132	143	144	149		
	T4/T5	230	CFM	1312	1275	1216	1153	1096	1028	943	869	816
			Watts	260	269	274	285	295	300	304	310	316
<hr/>												
Horizontal Position		Motor sp	Volts	Static								
Model				0.1	0.2	0.3	0.4	0.5	0.6	0.7	0.8	0.9
GPH1630M41*	T1	230	CFM	743	707	595	513					
			Watts	61	73	77	85					
	T2/T3	230	CFM	1146	1098	1044	991	934	817	764	698	653
			Watts	157	170	176	186	194	201	210	215	215
	T4/T5	230	CFM	1440	1418	1364	1307	1265	1219	1168	1094	1049
			Watts	290	306	312	321	326	332	348	353	360
<hr/>												
Downshot Position		Motor sp	Volts	Static								
Model				0.1	0.2	0.3	0.4	0.5	0.6	0.7	0.8	0.9
GPH1630M41*	T1	230	CFM	722	672	574	509					
			Watts	60	74	80	89					
	T2/T3	230	CFM	1103	1038	978	922	806	731	676	622	564
			Watts	162	168	179	188	199	205	208	214	219
	T4/T5	230	CFM	1401	1357	1305	1244	1179	1118	1046	934	884
			Watts	311	326	318	334	341	349	353	352	357
<hr/>												
Horizontal Position		Motor sp	Volts	Static								
Model				0.1	0.2	0.3	0.4	0.5	0.6	0.7	0.8	0.9
GPH1636M41*	T1	230	CFM	846	762	716	585	519				
			Watts	74	83	94	98	108				
	T2/T3	230	CFM	1278	1214	1182	1129	1072	1013	950	853	788
			Watts	221	218	232	245	253	264	265	275	272
	T4/T5	230	CFM	1604	1560	1507	1468	1415	1364	1321	1276	1218
			Watts	396	402	408	424	426	423	444	454	454
<hr/>												
Downshot Position		Motor sp	Volts	Static								
Model				0.1	0.2	0.3	0.4	0.5	0.6	0.7	0.8	0.9
GPH1636M41*	T1	230	CFM	809	730	623	542	485	441			
			Watts	73	85	92	98	107	112			
	T2/T3	230	CFM	1284	1223	1175	1097	1031	974	871	804	761
			Watts	220	227	241	247	255	262	272	277	285
	T4/T5	230	CFM	1578	1539	1498	1452	1396	1332	1279	1224	1161
			Watts	401	409	421	425	438	439	452	453	455

AIR FLOW DATA

Horizontal Position		Motor sp Volts		Static								
Model				0.1	0.2	0.3	0.4	0.5	0.6	0.7	0.8	0.9
GPH1642M41*	T1	230	CFM	1030	955	908	826	761	678	633	563	504
			Watts	130	126	139	143	154	168	171	181	185
	T2/T3	230	CFM	1425	1373	1303	1250	1228	1158	1109	1042	982
			Watts	234	246	248	262	280	290	298	308	322
	T4/T5	230	CFM	1775	1718	1673	1643	1588	1532	1482	1431	1369
			Watts	416	424	430	454	458	466	478	488	490
<hr/>												
Downshot Position		Motor sp Volts		Static								
Model				0.1	0.2	0.3	0.4	0.5	0.6	0.7	0.8	0.9
GPH1642M41*	T1	230	CFM	1001	936	852	810	700	643	579	526	491
			Watts	125	133	136	154	160	166	172	177	185
	T2/T3	230	CFM	1411	1361	1299	1240	1173	1112	1048	955	887
			Watts	281	294	301	309	312	320	327	335	339
	T4/T5	230	CFM	1745	1690	1615	1580	1530	1470	1420	1370	1310
			Watts	425	435	440	465	468	476	488	498	500
<hr/>												
Horizontal Position		Motor sp Volts		Static								
Model				0.1	0.2	0.3	0.4	0.5	0.6	0.7	0.8	0.9
GPH1648M41*	T1	230	CFM	1167	1101	1045	992	939	870	802	732	681
			Watts	139	144	156	165	177	193	203	217	223
	T2/T3	230	CFM	1723	1637	1598	1554	1509	1467	1420	1361	1295
			Watts	372	370	381	390	404	411	420	427	441
	T4/T5	230	CFM	2012	1965	1912	1871	1809	1770	1741	1691	1635
			Watts	578	593	599	606	610	627	626	634	638
<hr/>												
Downshot Position		Motor sp Volts		Static								
Model				0.1	0.2	0.3	0.4	0.5	0.6	0.7	0.8	0.9
GPH1648M41*	T1	230	CFM	1155	1074	1023	969	896	805	755	667	626
			Watts	153	156	169	180	195	205	216	226	230
	T2/T3	230	CFM	1670	1596	1558	1484	1467	1383	1339	1259	1168
			Watts	383	392	399	408	419	434	436	447	449
	T4/T5	230	CFM	1949	1881	1853	1792	1753	1699	1621	1561	1522
			Watts	603	607	608	616	622	626	648	650	645

AIR FLOW DATA

GPG1660***M41**

Downshot

Speed Tap	Static	CFM	Amps	Wat s	RPM
T1	0.1	1334	1.65	180	627
	0.2	1286	1.75	192	665
	0.3	1212	1.83	202	715
	0.4	1144	1.94	216	759
	0.5	1077	1.99	222	792
	0.6	1039	2.10	238	830
	0.7	953	2.17	248	874
	0.8	904	2.27	258	913
	0.9	825	2.30	266	940
T2	0.1	1512	2.12	240	682
	0.2	1469	2.24	254	720
	0.3	1397	2.31	264	759
	0.4	1333	2.44	282	803
	0.5	1285	2.54	296	836
	0.6	1221	2.59	304	874
	0.7	1173	2.72	322	913
	0.8	1118	2.77	328	946
	0.9	1049	2.90	344	984
T3	0.1	2053	4.27	540	869
	0.2	2014	4.39	558	896
	0.3	1999	4.60	576	929
	0.4	1947	4.68	588	957
	0.5	1897	4.79	608	989
	0.6	1857	4.87	620	1012
	0.7	1763	4.99	640	1050
	0.8	1741	5.06	650	1072
	0.9	1669	5.19	668	1105
T4	0.1	2137	4.95	634	913
	0.2	2093	5.07	652	940
	0.3	2095	5.19	670	962
	0.4	2026	5.28	682	990
	0.5	1980	5.40	698	1018
	0.6	1961	5.49	720	1039
	0.7	1914	5.58	732	1072
	0.8	1845	5.70	742	1100
	0.9	1766	5.69	740	1127
T5	0.1	2299	5.70	742	942
	0.2	2233	5.80	748	969
	0.3	2217	5.90	768	990
	0.4	2157	6.07	786	1018
	0.5	2131	6.12	804	1045
	0.6	2060	6.21	816	1073
	0.7	2015	6.30	820	1095
	0.8	1940	6.27	816	1111
	0.9	1862	6.13	790	1128

Horizontal

Speed Tap	ESP in w.c.	CFM	Amps	Watts	RPM
T1	0.1	1355	1.57	174	599
	0.2	1281	1.66	182	651
	0.3	1235	1.76	196	693
	0.4	1168	1.81	202	726
	0.5	1118	1.94	218	775
	0.6	1049	2.03	232	819
	0.7	982	2.10	240	858
	0.8	922	2.14	246	885
	0.9	871	2.25	260	927
T2	0.1	1544	2.04	234	660
	0.2	1490	2.17	250	704
	0.3	1427	2.25	260	742
	0.4	1370	2.35	276	781
	0.5	1319	2.42	282	809
	0.6	1274	2.52	296	849
	0.7	1210	2.62	316	891
	0.8	1137	2.73	326	935
	0.9	1106	2.77	336	957
T3	0.1	2099	4.13	516	825
	0.2	2068	4.25	536	852
	0.3	2029	4.37	552	885
	0.4	1971	4.48	568	913
	0.5	1911	4.61	586	950
	0.6	1876	4.73	604	973
	0.7	1821	4.86	622	1012
	0.8	1792	4.91	630	1028
	0.9	1740	5.03	648	1067
T4	0.1	2233	4.76	608	863
	0.2	2168	4.91	628	896
	0.3	2125	5.02	640	924
	0.4	2070	5.14	660	951
	0.5	2050	5.27	678	979
	0.6	1980	5.41	696	1012
	0.7	1954	5.47	704	1034
	0.8	1893	5.60	724	1067
	0.9	1852	5.70	736	1089
T5	0.1	2322	5.44	710	904
	0.2	2294	5.55	726	934
	0.3	2254	5.68	742	958
	0.4	2201	5.80	766	990
	0.5	2147	5.93	782	1017
	0.6	2117	6.01	788	1039
	0.7	2081	6.12	808	1060
	0.8	2017	6.22	822	1094
	0.9	1932	6.10	804	1111

Notes

- Table represent dry coil without filter, to compensate for filter add 0.08" to measured E.S.P.
- SCFM correction for wet coil = 4%.
- 5-ton models are shipped from the factory with speed tap set on T4.

Airflow Pressure Drop of Downflow Economizer for 3 to 6 Ton Roof top Units (100% Return Air)

SCFM	800	1000	1200	1400	1600	1800	2000	2200	2400	2600	2800
in. WG	0.02	0.04	0.05	0.07	0.09	0.12	0.14	0.17	0.21	0.24	0.28

WIRING DIAGRAMS

WARNING

HIGH VOLTAGE!
 DISCONNECT ALL POWER BEFORE SERVICING OR INSTALLING THIS UNIT. MULTIPLE POWER SOURCES MAY BE PRESENT. FAILURE TO DO SO MAY CAUSE PROPERTY DAMAGE, PERSONAL INJURY OR DEATH.

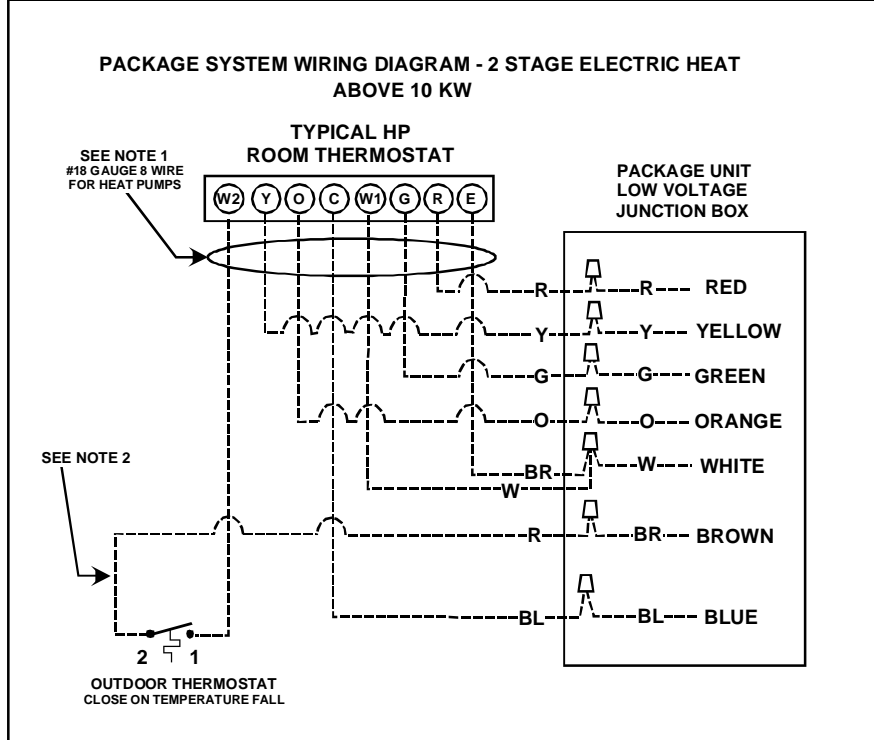
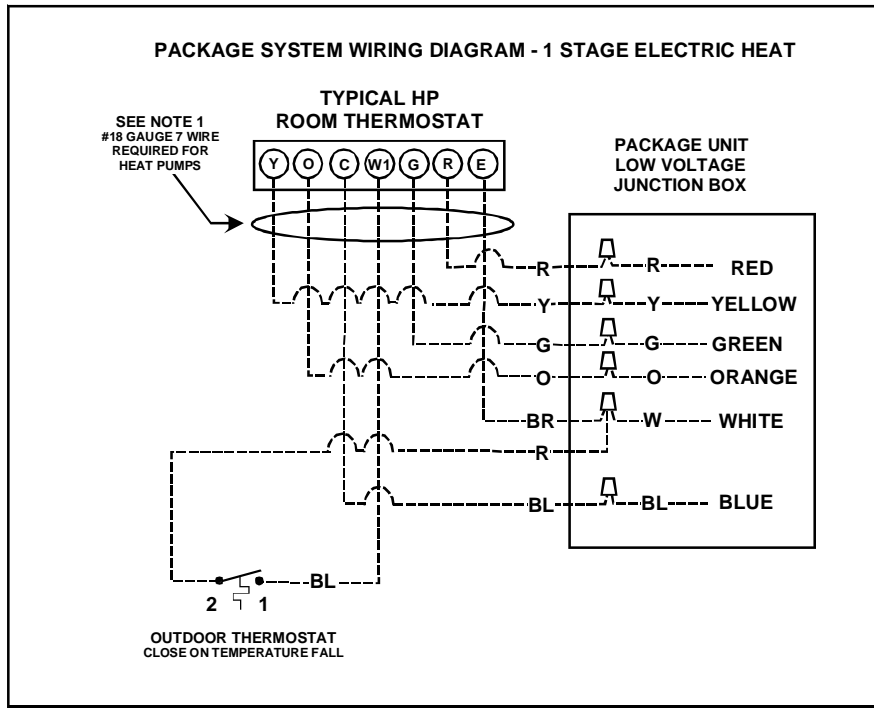

NOTES:

- 1) "O" and "E" used on heat pumps only.
- 2) Connect wire from terminal #1 on outdoor thermostat to the white wire on package units if single stage indoor thermostat is used.

Color Codes

R - Red
Y - Yellow
BL - Blue
BR - Brown
O - Orange
W - White
G - Green

OT18-60A OUTDOOR THERMOSTAT

Wiring is subject to change. Always refer to the wiring diagram on the unit for the most up-to-date wiring.

WIRING DIAGRAMS

WARNING

HIGH VOLTAGE!
 DISCONNECT ALL POWER BEFORE SERVICING OR INSTALLING THIS UNIT. MULTIPLE POWER SOURCES MAY BE PRESENT. FAILURE TO DO SO MAY CAUSE PROPERTY DAMAGE, PERSONAL INJURY OR DEATH.

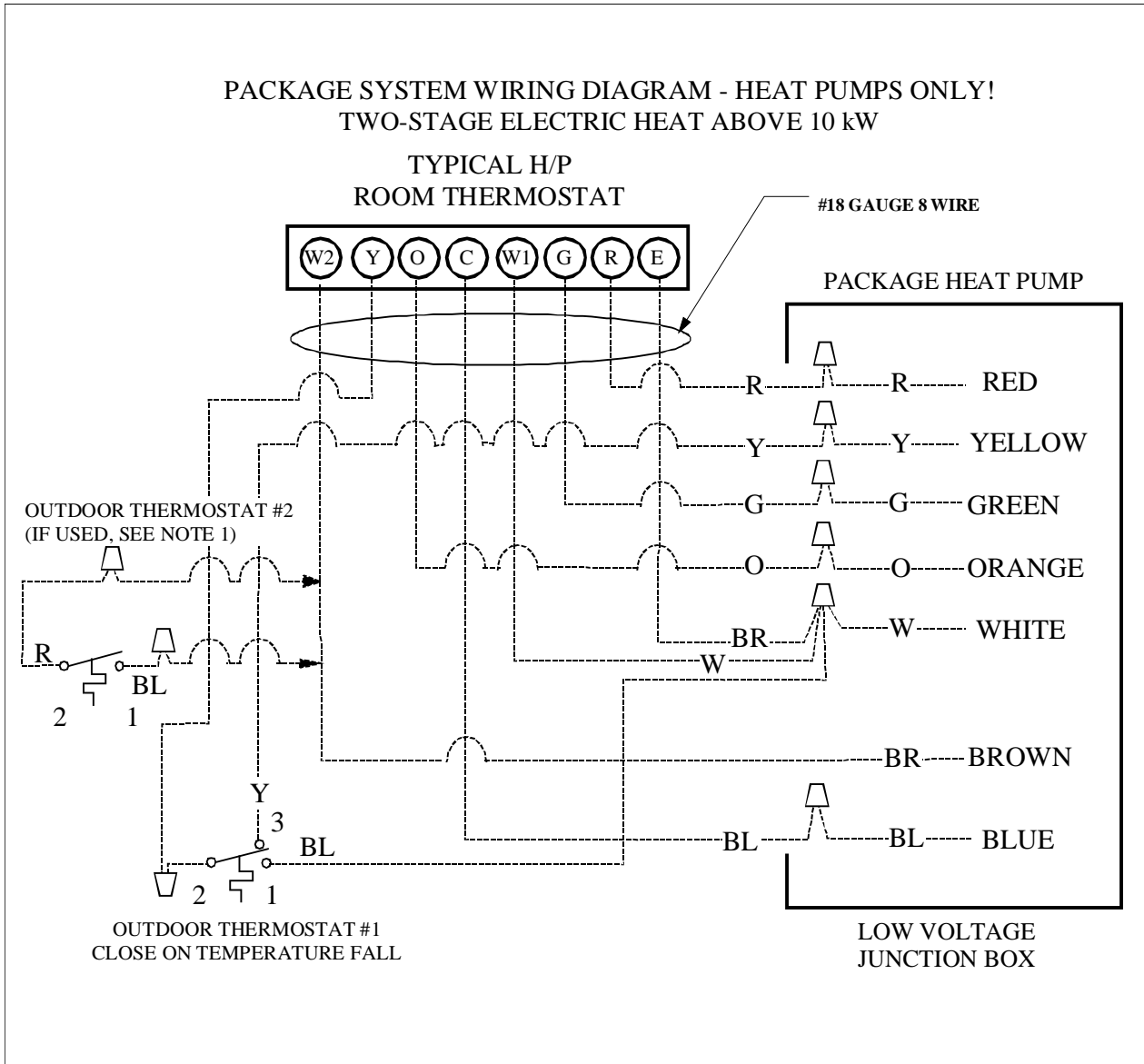

For outdoor temperatures below 0° F with 50% or higher relative humidity, set outdoor thermostat at 0° F

NOTE 1: OT18 #2 CAN BE CONNECTED BETWEEN W2 OF THERMOSTAT AND BROWN WIRE IF DESIRED.

COLOR CODES
 R --RED
 Y --YELLOW
 BL-BLUE
 BR-BROWN
 O --ORANGE
 W -WHITE
 G --GREEN

OT18-60A OUTDOOR THERMOSTAT

Wiring is subject to change. Always refer to the wiring diagram on the unit for the most up-to-date wiring.

WIRING DIAGRAMS

A/GPH16[24-48]M41*



WARNING

HIGH VOLTAGE!
 DISCONNECT ALL POWER BEFORE SERVICING OR INSTALLING THIS UNIT. MULTIPLE POWER SOURCES MAY BE PRESENT. FAILURE TO DO SO MAY CAUSE PROPERTY DAMAGE, PERSONAL INJURY OR DEATH.



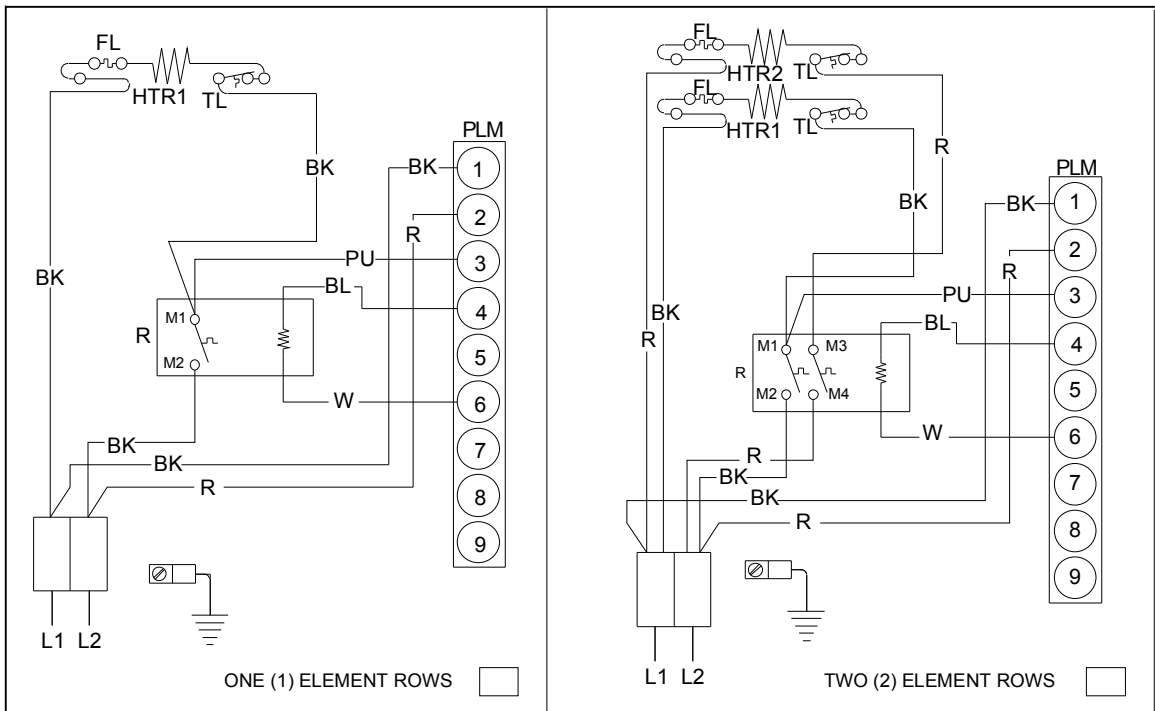

5 KW

10 KW

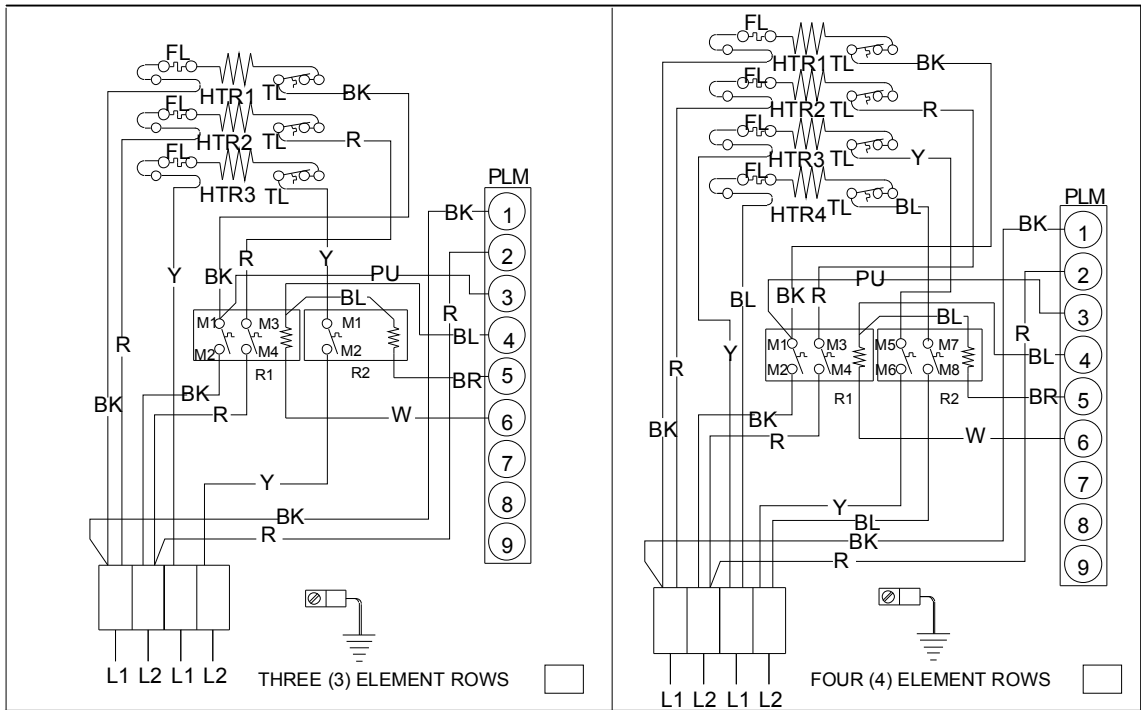

15 KW

20 KW

SINGLE PHASE HKP / HKR** HEAT KIT**

Wiring is subject to change. Always refer to the wiring diagram on the unit for the most up-to-date wiring.

WIRING DIAGRAMS

A/GPH16[24-48]M41*



WARNING HIGH VOLTAGE!
DISCONNECT ALL POWER BEFORE SERVICING OR INSTALLING THIS UNIT. MULTIPLE POWER SOURCES MAY BE PRESENT. FAILURE TO DO SO MAY CAUSE PROPERTY DAMAGE, PERSONAL INJURY OR DEATH.



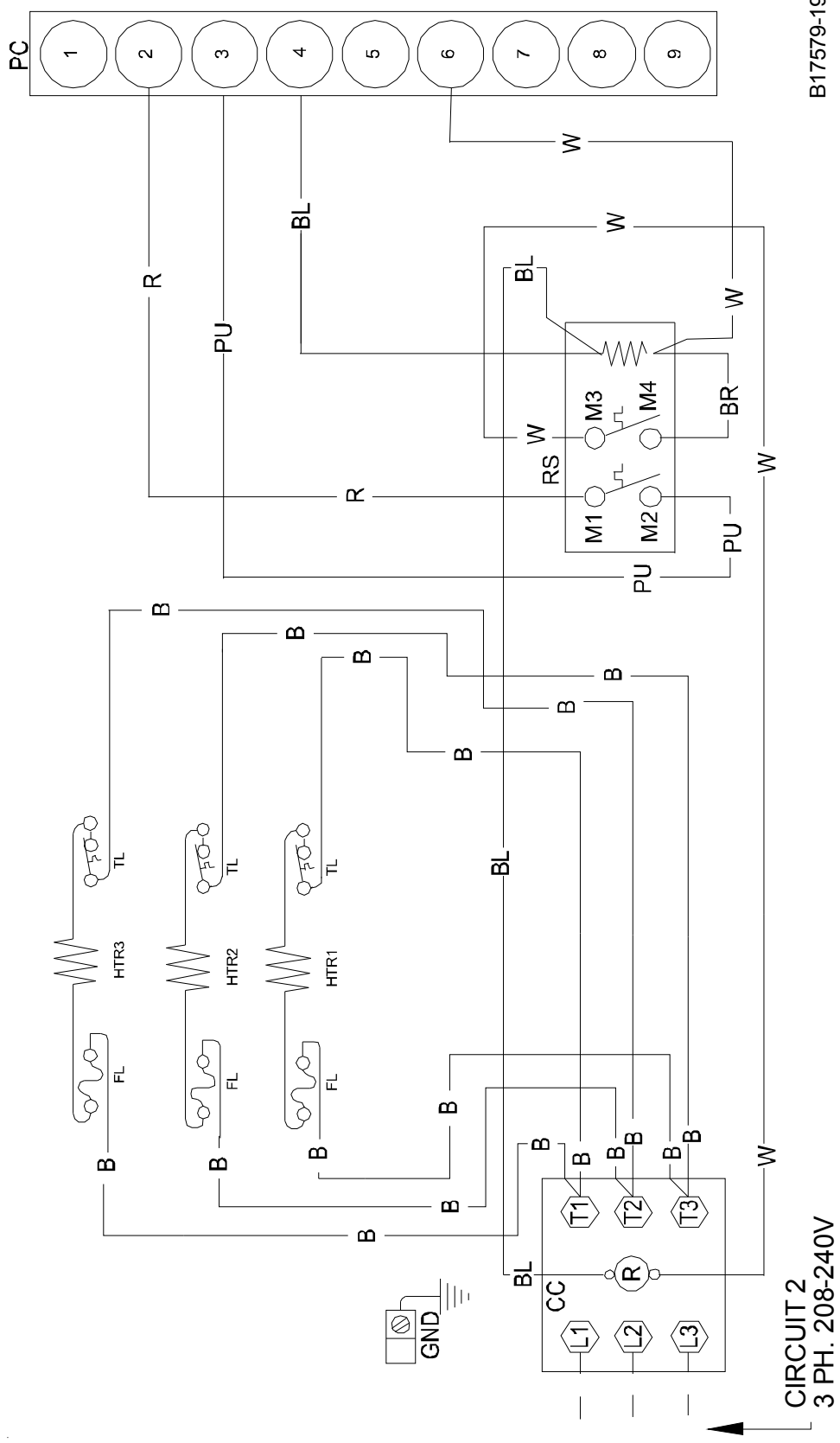

B17579-19

3-PHASE HKR** HEAT KIT - 15 KW & 20 KW

Wiring is subject to change. Always refer to the wiring diagram on the unit for the most up-to-date wiring.

HEATER KITS	
Part Number	Description
EHK1-10	10 KW Electric Heat Kit, 240V Single Phase
EHK1-15	15 KW Electric Heat Kit, 240V Single Phase
EHK1-20	20 KW Electric Heat Kit, 240V Single Phase

MINIMUM AIRFLOW FOR ELECTRIC HEAT

Unit	HEATER KIT MODEL NUMBER	MINIMUM CFM
5 ton	EHK*-10	1700
	EHK*-15	1700
	EHK*-20	1800



ATTENTION INSTALLING PERSONNEL

Use only the heater kit specified for each model as dictated by the table above.

HEATER KIT WIRING DIAGRAMS

EHK1-10

WARNING

HIGH VOLTAGE!
 DISCONNECT ALL POWER BEFORE SERVICING OR INSTALLING THIS UNIT. MULTIPLE POWER SOURCES MAY BE PRESENT. FAILURE TO DO SO MAY CAUSE PROPERTY DAMAGE, PERSONAL INJURY OR DEATH.

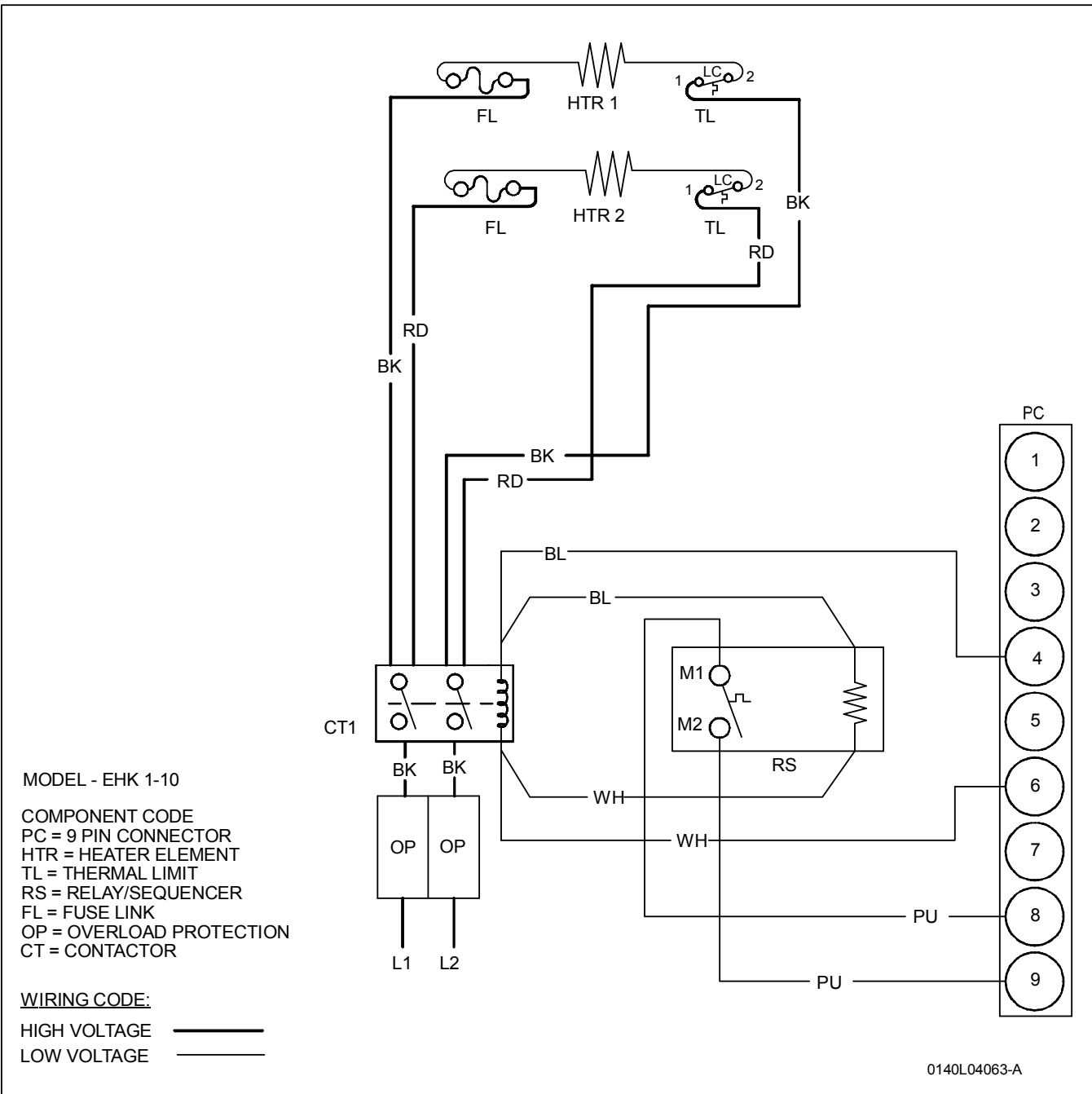

EHK1 - 10 HEAT KIT - 10 KW

Wiring is subject to change. Always refer to the wiring diagram on the unit for the most up-to-date wiring.

HEATER KIT WIRING DIAGRAMS

EHK1-15

WARNING

HIGH VOLTAGE!
 DISCONNECT ALL POWER BEFORE SERVICING OR INSTALLING THIS UNIT. MULTIPLE POWER SOURCES MAY BE PRESENT. FAILURE TO DO SO MAY CAUSE PROPERTY DAMAGE, PERSONAL INJURY OR DEATH.

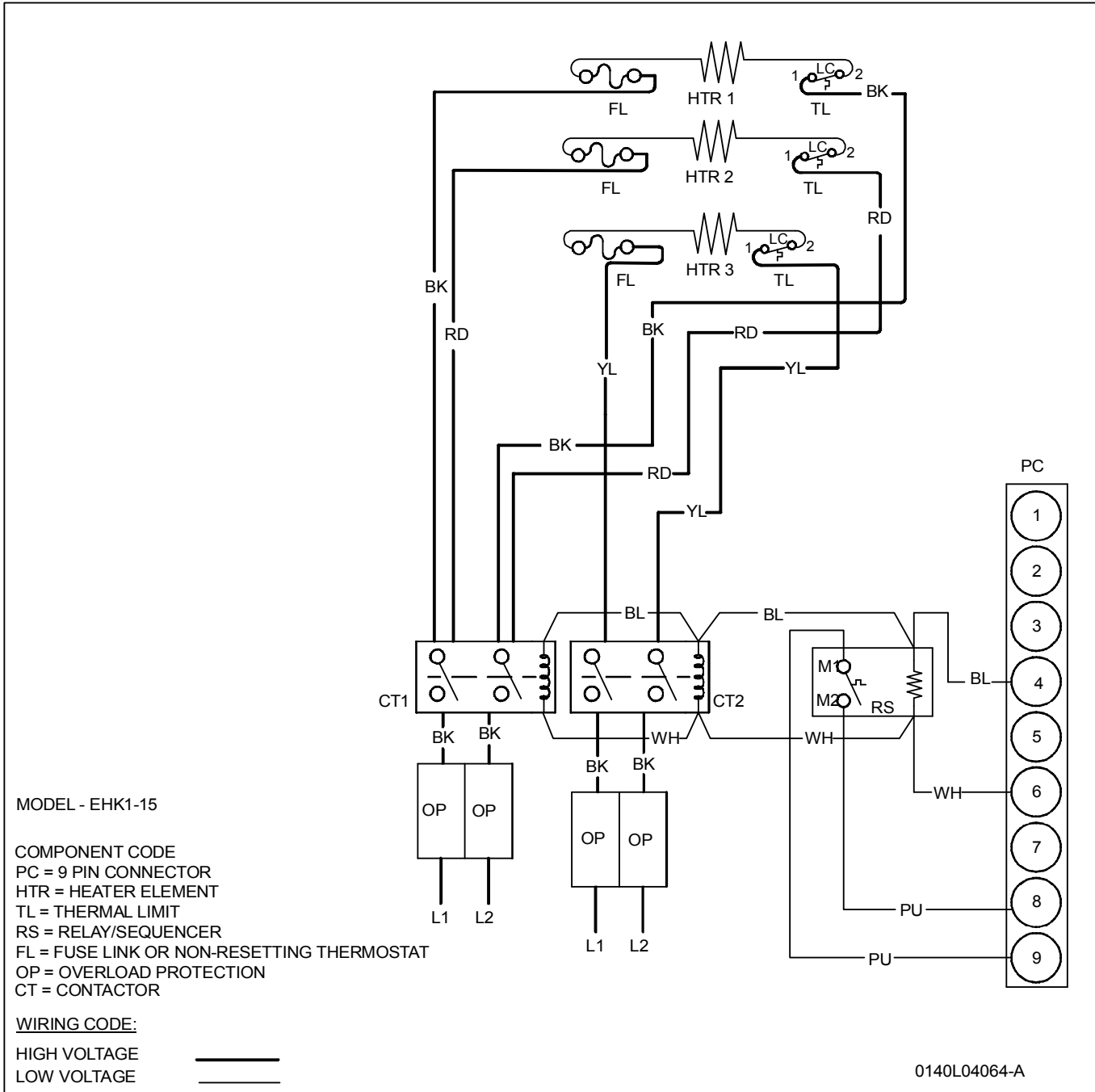

EHK1 - 15 HEAT KIT - 15 KW

Wiring is subject to change. Always refer to the wiring diagram on the unit for the most up-to-date wiring.

HEATER KIT WIRING DIAGRAMS

EHK1-20

WARNING

HIGH VOLTAGE!
 DISCONNECT ALL POWER BEFORE SERVICING OR INSTALLING THIS UNIT. MULTIPLE POWER SOURCES MAY BE PRESENT. FAILURE TO DO SO MAY CAUSE PROPERTY DAMAGE, PERSONAL INJURY OR DEATH.

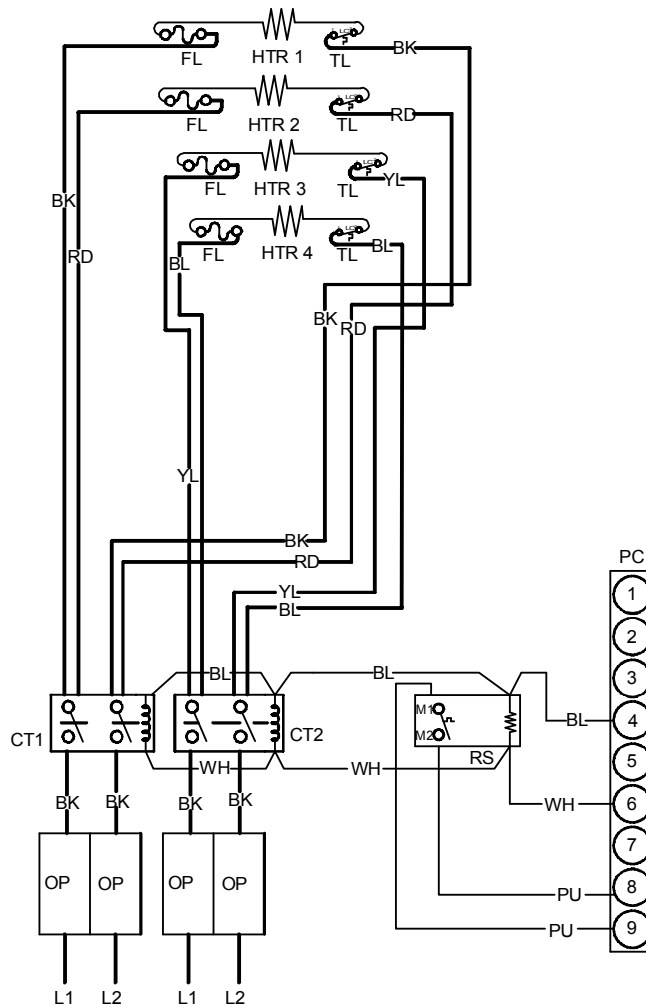

MODEL - EHK1-20 EHK1-18

COMPONENT CODE
 PC = 9 PIN CONNECTOR
 HTR = HEATER ELEMENT
 TL = THERMAL LIMIT
 RS = RELAY/SEQUENCER
 FL = FUSE LINK OR NON-RESETTING THERMOSTAT
 OP = OVERLOAD PROTECTION
 CT = CONTACTOR

WIRING CODE:

HIGH VOLTAGE
 LOW VOLTAGE

0140L04065-A

EHK1 - 20 HEAT KIT - 20 KW

Wiring is subject to change. Always refer to the wiring diagram on the unit for the most up-to-date wiring.

HEATER KIT WIRING DIAGRAMS

EHK*-10/EHK*-15

WARNING

HIGH VOLTAGE!
 DISCONNECT ALL POWER BEFORE SERVICING OR INSTALLING THIS UNIT. MULTIPLE POWER SOURCES MAY BE PRESENT. FAILURE TO DO SO MAY CAUSE PROPERTY DAMAGE, PERSONAL INJURY OR DEATH.

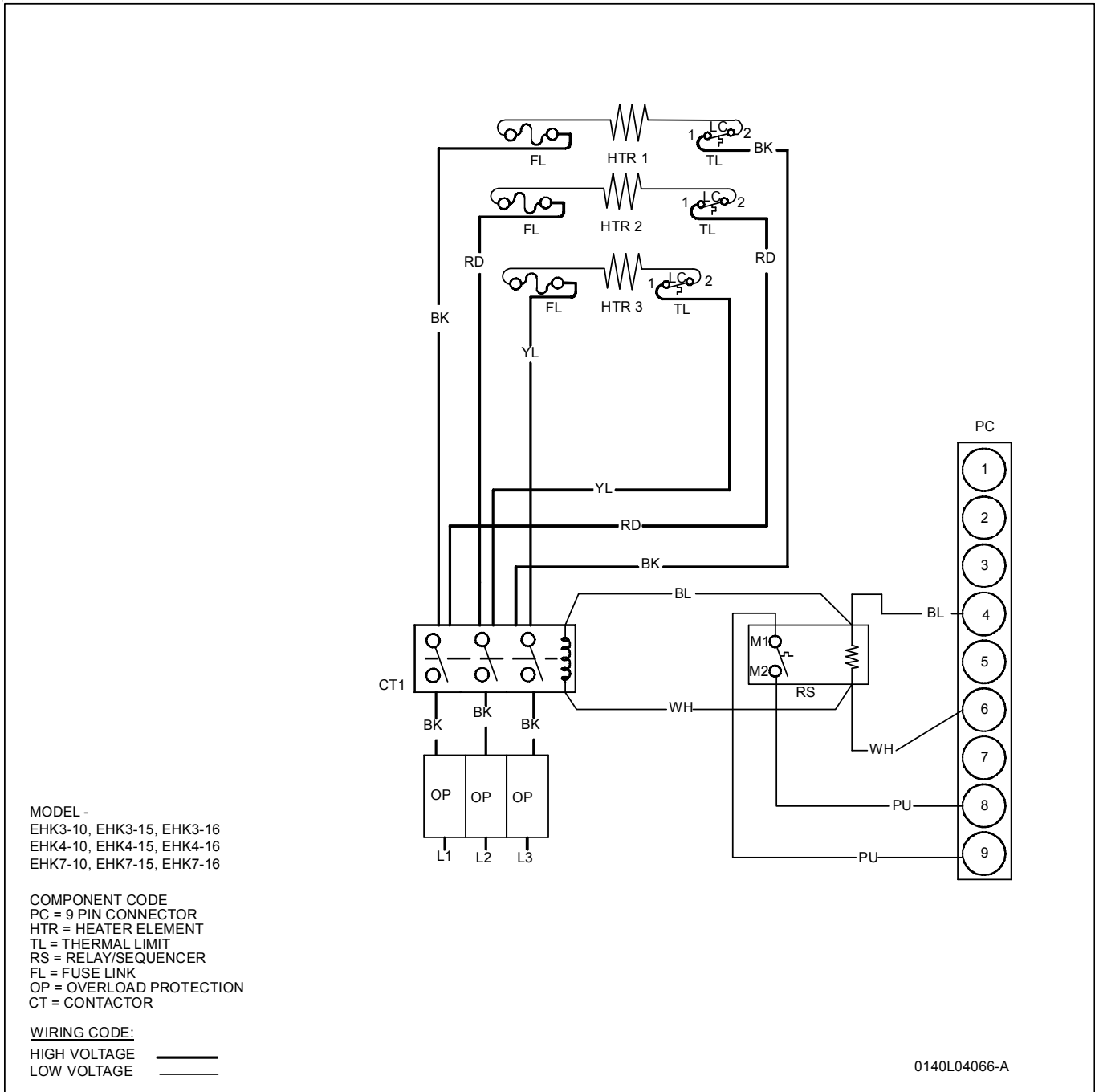

EHK3-10 HEAT KITS - 10 KW, EHK3-15 HEAT KITS - 15 KW
EHK4-10 HEAT KITS - 10 KW, EHK4-15 HEAT KITS - 15 KW
EHK7-10 HEAT KITS - 10 KW, EHK7-15 HEAT KITS - 15 KW

Wiring is subject to change. Always refer to the wiring diagram on the unit for the most up-to-date wiring.

WARNING

HIGH VOLTAGE!
 DISCONNECT ALL POWER BEFORE SERVICING OR INSTALLING THIS UNIT. MULTIPLE POWER SOURCES MAY BE PRESENT. FAILURE TO DO SO MAY CAUSE PROPERTY DAMAGE, PERSONAL INJURY OR DEATH.

FOR UNITS WITH SERIALS 1409 AND NEWER

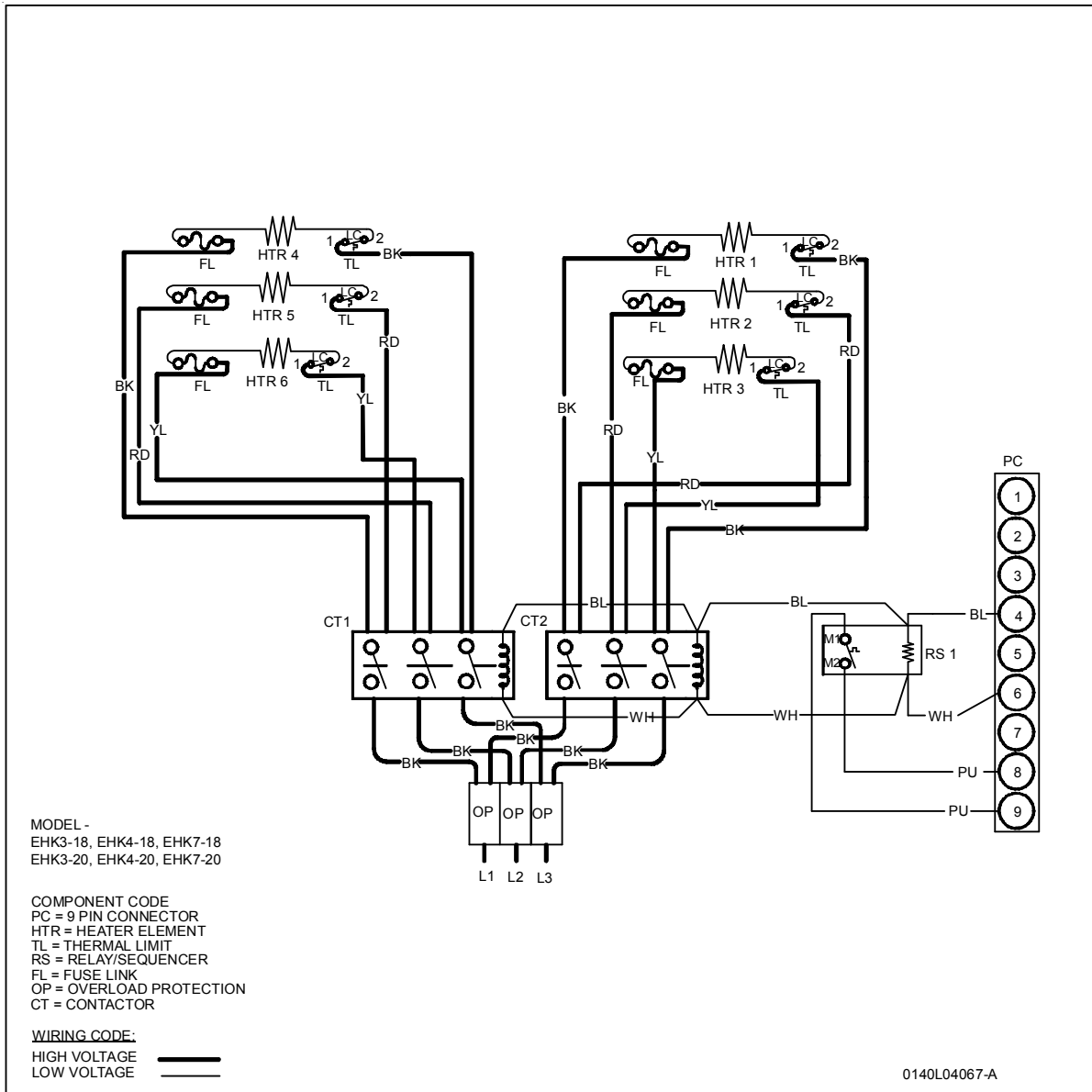

EHK3 - 20 HEAT KIT - 20KW

EHK4 - 20 HEAT KIT - 20KW

EHK7 - 20 HEAT KIT - 20KW

Wiring is subject to change. Always refer to the wiring diagram on the unit for the most up-to-date wiring.

WIRING DIAGRAMS

WARNING

HIGH VOLTAGE!
 DISCONNECT ALL POWER BEFORE SERVICING OR INSTALLING THIS UNIT. MULTIPLE POWER SOURCES MAY BE PRESENT. FAILURE TO DO SO MAY CAUSE PROPERTY DAMAGE, PERSONAL INJURY OR DEATH.

ECONOMIZER

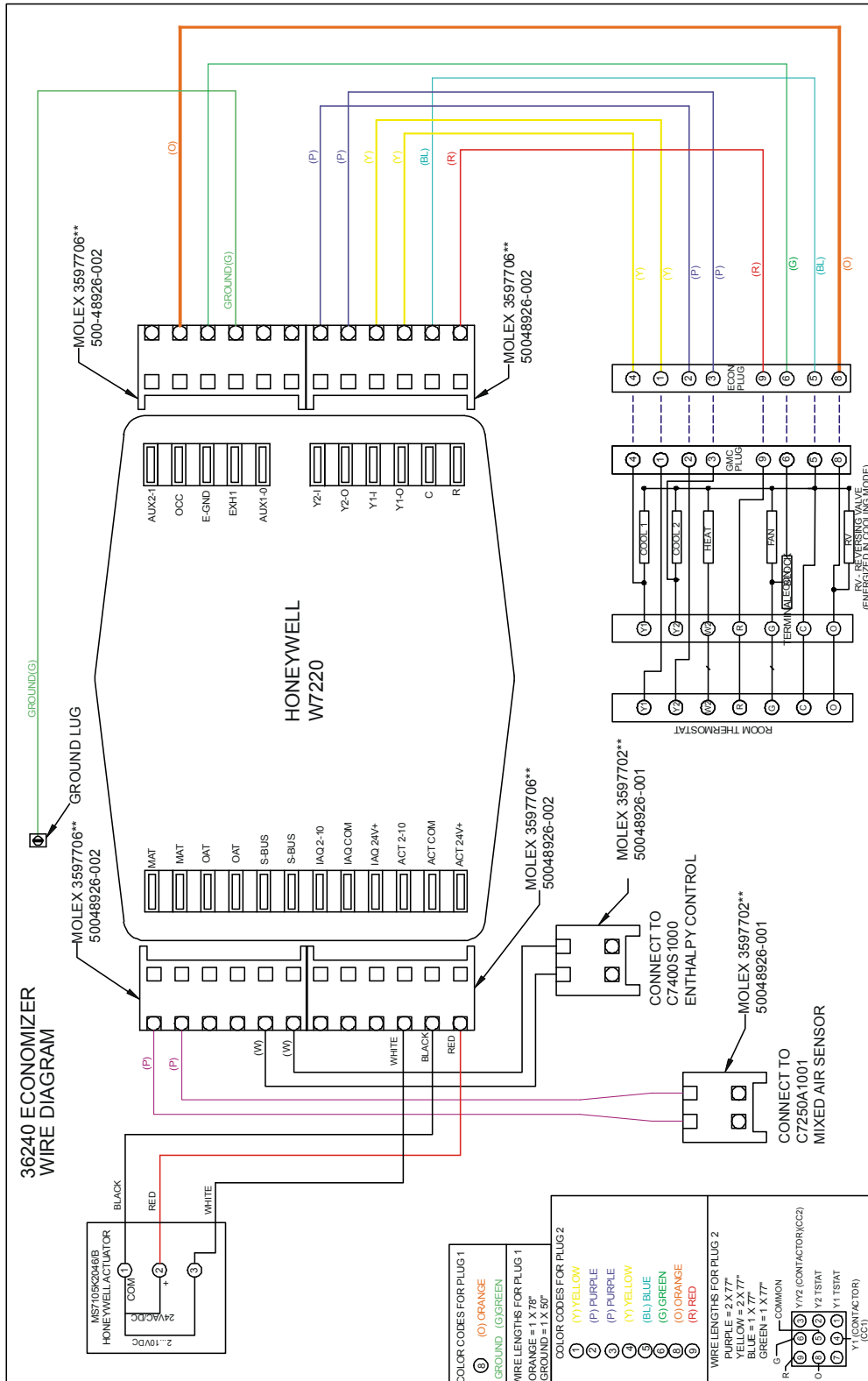

GPJMED (Downflow) and DHZECONJPGCH (Horizontal)

Wiring is subject to change. Always refer to the wiring diagram on the unit for the most up-to-date wiring.



WARNING

HIGH VOLTAGE!
 DISCONNECT ALL POWER BEFORE SERVICING OR INSTALLING THIS UNIT. MULTIPLE POWER SOURCES MAY BE PRESENT. FAILURE TO DO SO MAY CAUSE PROPERTY DAMAGE, PERSONAL INJURY OR DEATH.



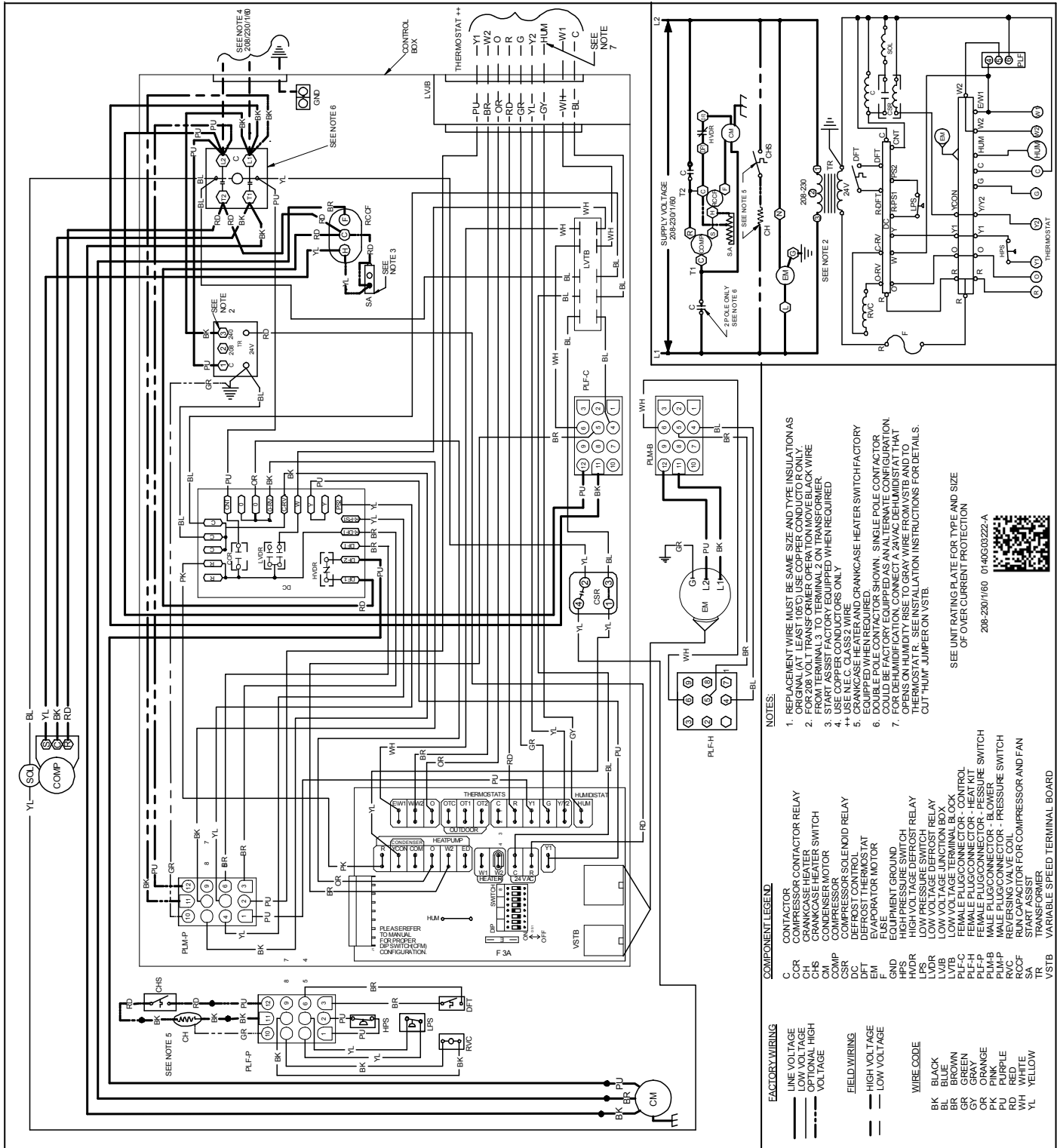

- NOTES:**
1. REPLACEMENT WIRE MUST BE SAME SIZE AND TYPE INSULATION AS ORIGINAL (AT LEAST 105°C) USE COPPER CONDUCTOR ONLY.
 2. FOR 208 VOLT TRANSFORMER OPERATION MOVE BLACK WIRE TO THE OTHER TERMINAL ON THE TRANSFORMER.
 3. START ASSIST FACTORY EQUIPPED WHEN REQUIRED.
 4. USE COPPER CONDUCTORS ONLY.
 5. CRANKCASE HEATER AND CRANKCASE HEATER SWITCH FACTORY EQUIPPED ON ALL UNITS.
 6. DOUBLE POLE CONTACTOR SHOWN. SINGLE POLE CONTACTOR COULD BE FACTORY EQUIPPED AS AN ALTERNATE CONFIGURATION.
 7. FOR DEHUMIDIFICATION, CONNECT A 24VAC DEHUMIDISTAT THAT OPENS ON HUMIDITY RISE TO GRAY WIRE FROM HUMISTAT AND TO THE HUMIDISTAT TERMINAL IN THE WIRING INSTRUCTIONS FOR DETAILS. CUT THRU JUMPER ON VSTB.

COMPONENT LEGEND

C	CONTACTOR
CCR	COMPRESSOR CONTACTOR RELAY
CHS	CRANKCASE HEATER SWITCH
CM	COMPRESSOR MOTOR
COMP	COMPRESSOR
CSR	COMPRESSOR SOLENOID RELAY
DEF	DEFROST THERMOSTAT
EFM	EVAPORATOR MOTOR
F	FUSE
GND	EQUIPMENT GROUND
HDR	HIGH VOLTAGE DEFROST RELAY
LVD	LOW VOLTAGE DEFROST RELAY
LVR	LOW VOLTAGE DEFROST RELAY
LVB	LOW VOLTAGE JUNCTION BOX
PLC	PLUG CONNECTOR - CONTROL
PLC-F	FEMALE PLUG CONNECTOR - HEAT KIT
PLF-F	FEMALE PLUG CONNECTOR - PRESSURE SWITCH
PLM-B	MALE PLUG CONNECTOR - BLOWER
PLM-P	MALE PLUG CONNECTOR - PRESSURE SWITCH
RVC	REVERSING VALVE COIL
RCCF	START ASSIST FOR COMPRESSOR AND FAN
SA	START ASSIST
TR	TRANSFORMER
VSTB	VARIABLE SPEED TERMINAL BOARD

FACTORY WIRING

---	LINE VOLTAGE
---	LOW VOLTAGE
---	OPTIONAL HIGH VOLTAGE
---	VOLTAGE

FIELD WIRING

---	HIGH VOLTAGE
---	LOW VOLTAGE

WIRE CODE

BK	BLACK
BL	BLUE
BR	BROWN
GR	GREEN
GY	GRAY
OR	ORANGE
PK	PINK
PU	PURPLE
RD	RED
WH	WHITE
YL	YELLOW

SEE UNIT RATING PLATE FOR TYPE AND SIZE OF OVER CURRENT PROTECTION
 208-230/1660 01-40G03222-A

Wiring is subject to change. Always refer to the wiring diagram on the unit for the most up-to-date wiring.

WARNING
 HIGH VOLTAGE!
 DISCONNECT ALL POWER BEFORE SERVICING OR INSTALLING THIS UNIT. MULTIPLE POWER SOURCES MAY BE PRESENT. FAILURE TO DO SO MAY CAUSE PROPERTY DAMAGE, PERSONAL INJURY OR DEATH.

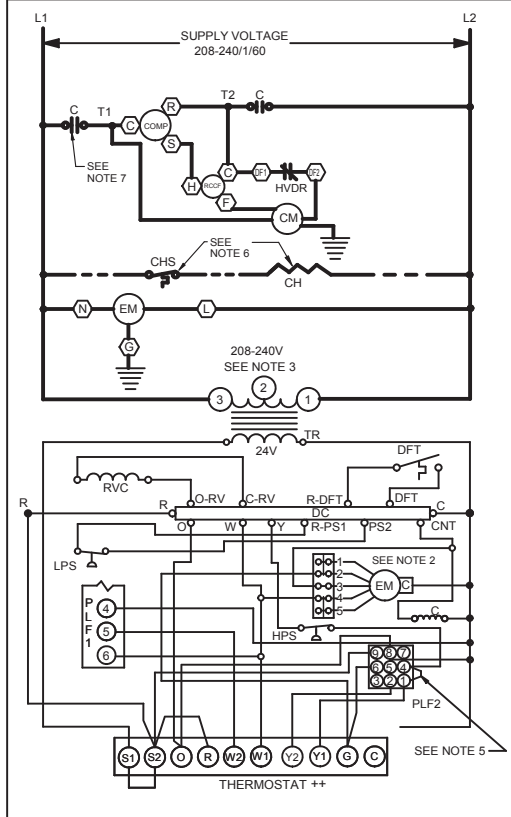
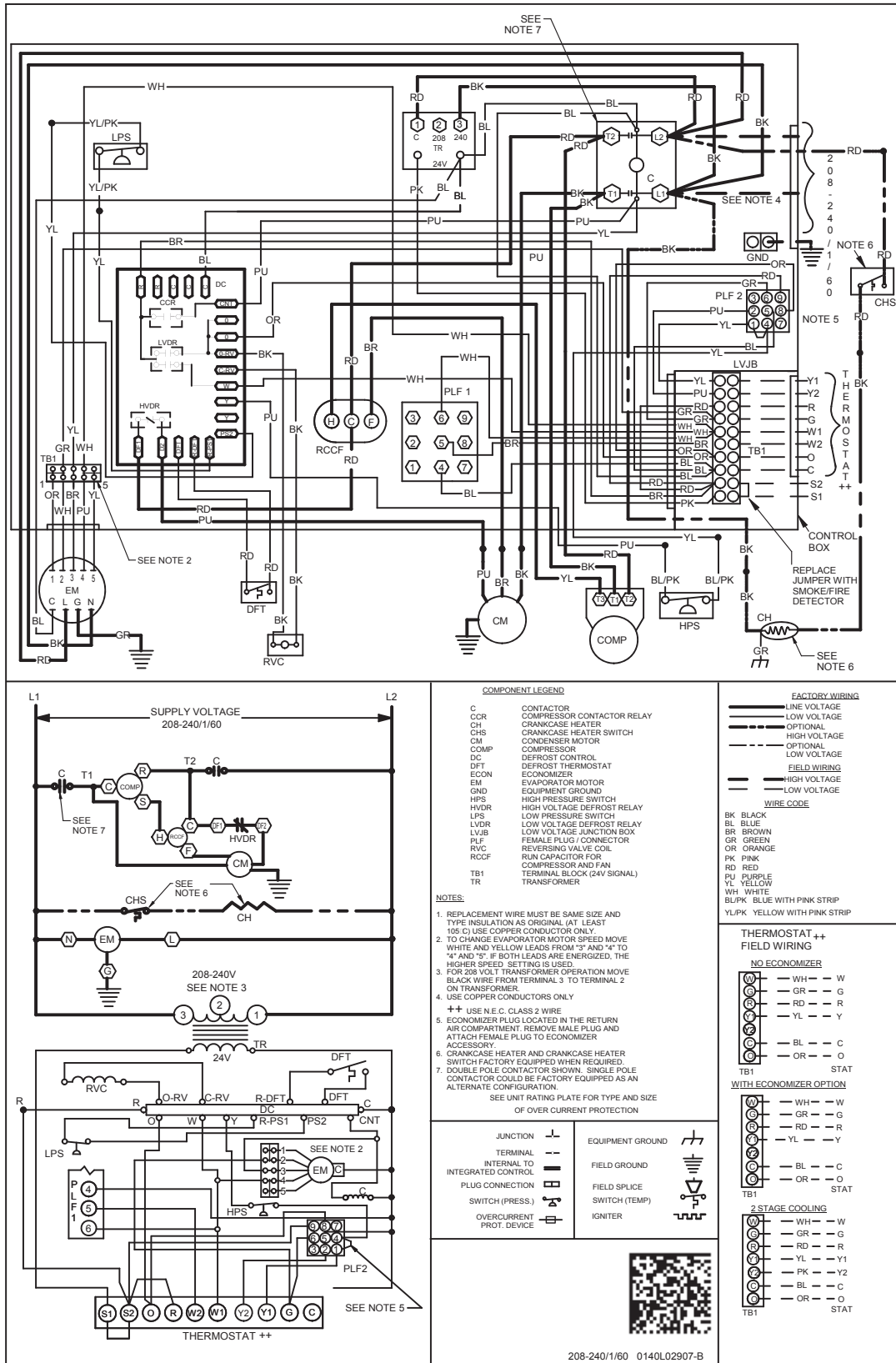

COMPONENT LEGEND

C	CONTACTOR
CCR	COMPRESSOR CONTACTOR RELAY
CH	CRANKCASE HEATER
CHS	CRANKCASE HEATER SWITCH
CM	CONDENSER MOTOR
COMP	COMPRESSOR
DC	DEFROST CONTROL
DFT	DEFROST THERMOSTAT
ECONOM	ECONOMIZER
EM	EVAPORATOR MOTOR
GND	EQUIPMENT GROUND
HPS	HIGH PRESSURE SWITCH
HVDR	HIGH VOLTAGE DEFROST RELAY
LPS	LOW PRESSURE SWITCH
LVDR	LOW VOLTAGE DEFROST RELAY
LVJB	LOW VOLTAGE JUNCTION BOX
PLF	FEMALE PLUG/CONNECTOR
RVC	REVERSING VALVE COIL
RCCF	RUN CAPACITOR FOR COMPRESSOR AND FAN
TB1	TERMINAL BLOCK (24V SIGNAL)
TR	TRANSFORMER

NOTES:

- REPLACEMENT WIRE MUST BE SAME SIZE AND TYPE INSULATION AS ORIGINAL (AT LEAST 105 C) USE COPPER CONDUCTOR ONLY.
- TO CHANGE EVAPORATOR MOTOR SPEED MOVE WHITE AND YELLOW LEADS FROM "7" AND "4" TO "4" AND "5" IF BOTH LEADS ARE ENERGIZED, THE HIGHER SPEED SETTING IS USED.
- FOR 208 VOLT TRANSFORMER OPERATION MOVE BLACK WIRE FROM TERMINAL 3 TO TERMINAL 2 ON TRANSFORMER.
- USE COPPER CONDUCTORS ONLY
 ++ USE N.E.C. CLASS 2 WIRE
- ECONOMIZER PLUG LOCATED IN THE RETURN AIR COMPARTMENT. REMOVE MALE PLUG AND ATTACH FEMALE PLUG TO ECONOMIZER ACCESSORY.
- CRANKCASE HEATER AND CRANKCASE HEATER SWITCH FACTORY EQUIPPED WHEN REQUIRED.
- DOUBLE POLE CONTACTOR SHOWN. SINGLE POLE CONTACTOR COULD BE FACTORY EQUIPPED AS AN ALTERNATE CONFIGURATION.

SEE UNIT RATING PLATE FOR TYPE AND SIZE OF OVER CURRENT PROTECTION

JUNCTION	—+—	EQUIPMENT GROUND	—⏏—
TERMINAL	— —	FIELD GROUND	—⏏—
INTERNAL TO INTEGRATED CONTROL	— —	FIELD SPICE	— —
PLUG CONNECTION	— —	SWITCH (TEMP)	— —
SWITCH (PRESS.)	— —	IGNITER	— —
OVERCURRENT PROT. DEVICE	— —		

208-240/1/60 0140L02907-B

FACTORY WIRING

- SOLID LINE: LINE VOLTAGE
- DASHED LINE: LOW VOLTAGE
- DOTTED LINE: OPTIONAL HIGH VOLTAGE
- DASHED LINE WITH DOTS: OPTIONAL LOW VOLTAGE

FIELD WIRING

- SOLID LINE WITH DOTS: HIGH VOLTAGE
- DASHED LINE WITH DOTS: LOW VOLTAGE

WIRE CODE

- BK BLACK
- BL BLUE
- BR BROWN
- GR GREEN
- OR ORANGE
- PK PINK
- RD RED
- PU PURPLE
- YL YELLOW
- WH WHITE
- BL/PK BLUE WITH PINK STRIP
- YL/PK YELLOW WITH PINK STRIP

THERMOSTAT ++ FIELD WIRING

NO ECONOMIZER

WH	W
GR	G
RD	R
YL	Y
BL	C
OR	O

TB1 STAT

WITH ECONOMIZER OPTION

WH	W
GR	G
RD	R
YL	Y
BL	C
OR	O

TB1 STAT

2 STAGE COOLING

WH	W
GR	G
RD	R
YL	Y1
PK	Y2
BL	C
OR	O

TB1 STAT

Wiring is subject to change. Always refer to the wiring diagram on the unit for the most up-to-date wiring.

WARNING

HIGH VOLTAGE!

DISCONNECT ALL POWER BEFORE SERVICING OR INSTALLING THIS UNIT. MULTIPLE POWER SOURCES MAY BE PRESENT. FAILURE TO DO SO MAY CAUSE PROPERTY DAMAGE, PERSONAL INJURY OR DEATH.

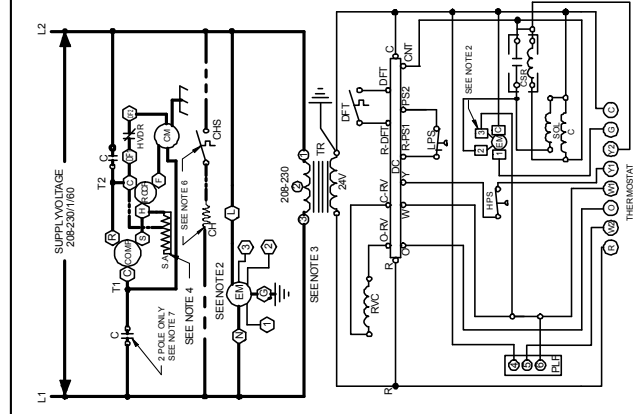
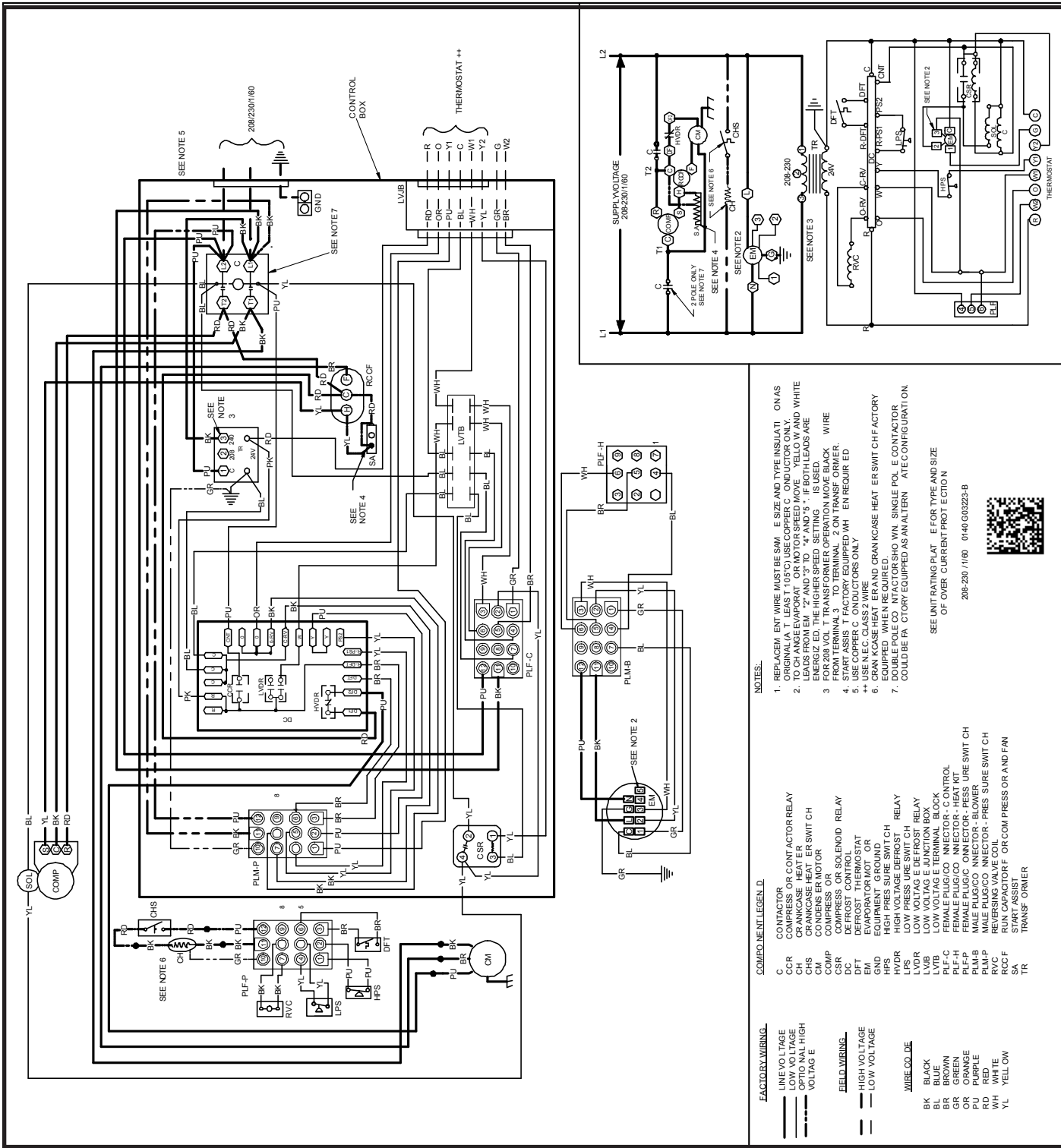

- NOTES:**
1. BERRACEM ENT WIRE MUST BE SAME SIZE AND TYPE INSULATI ON AS ORIGINAL (A T LEAST T 105°C) USE COPPER C ONDUCTOR ONLY.
 2. TO CH ANGE EVAPORAT OR MOTOR SPEED MOVE 'YELLOW AND WHITE LEADS FROM EM '2' AND '3' TO '4' AND '5'. IF BOTH LEADS ARE ENERGIZ ED THE HIGHER-SPEED SETTING IS USED.
 3. FROM TERMINAL 3 OF TRANSFORMER TO TERMINAL 2 ON TRANSFORMER.
 4. START ASSIST T FACTORY EQUIPPED WHEN REQUIRED.
 5. USE COPPER C ONDUCTORS ONLY.
 6. USE NECC CLASS 2 WIRE AND CRANKCASE HEAT ER SWITCH FACTORY EQUIPPED WHEN REQUIRED.
 7. DOUBLE POLE CO NTACTOR SHO WN SINGLE POLE CO NTACTOR COULD BE FA CTORY EQUIPPED AS AN ALTERN ATE C ONFIGURATION.

COMPONENT LEGEND:

CCR	CONTACTOR OR CONTACTOR RELAY
CH	CRANKCASE HEAT ER SWITCH
CHS	CONDENSER HEAT ER MOTOR
CM	COMPRESSOR
DC	DEFROST CONTROL
DFT	DEFROST THERMOSTAT
EM	EVAPORATOR MOTOR
GND	EQUIPMENT GROUND
HVDR	HIGH VOLTAGE DEFROST RELAY
LPS	LOW PRESSURE SWITCH
LVD	LOW VOLTAGE DEFROST RELAY
LVB	LOW VOLTAGE JUNCTION BOX
PLM-B	PLUG/CO NNECTOR - CONTROL
PLF-C	FEMALE PLUG/CO NNECTOR - HEAT KIT
PLF-H	FEMALE PLUG/CO NNECTOR - PRESSURE SWITCH
PLM-B	MALE PLUG/CO NNECTOR - BLOWER
PLF-P	MALE PLUG/CO NNECTOR - PRESSURE SWITCH
RVC	REVERSING VALVE COIL
RCCF	RUN CAPACITOR OR COMPRESSOR AND FAN TRANSFORMER
SA	START ASSIST
TR	TRANSFORMER

FACTORY WIRING:

---	LINE VOLTAGE
---	LOW VOLTAGE
---	HIGH VOLTAGE
---	VOLTAGE

FIELD WIRING:

---	HIGH VOLTAGE
---	LOW VOLTAGE

WIRE COLOR CODE:

BK	BLACK
BR	BROWN
GR	GREEN
OR	ORANGE
PU	PURPLE
RD	RED
WH	WHITE
YL	YELLOW

SEE UNIT RATING PLATE FOR TYPE AND SIZE OF OVER CURRENT PROTECTION

208-220/1160 0140 G0323-B



Wiring is subject to change. Always refer to the wiring diagram on the unit for the most up-to-date wiring.

