

Instruction Sheet

Kit Number: 72406900 & 73203100

DRIFT CUTTER KIT



WARNING: FAILURE TO FOLLOW INSTRUCTIONS could result in personal injury and/or damage to unit.

Read, understand, and follow all safety practices in Owner/Operator Manual before beginning.

Package Contents

Check contents of your kit for the parts listed (Figure 1):

Item	Part No.	Qty.	Description
1	00262159	2	Drift Cutter (72406900)
2	01024251	2	Cutter Bar (73203100)
3	06220800	4	5/16 x 3/4" Round Head Square Short-Neck Bolt (72406900)
4	0622200	4	5/16 x 1/2" Round Head Square Neck Bolt (73203100)
5	07534800	4	Clamping Knob

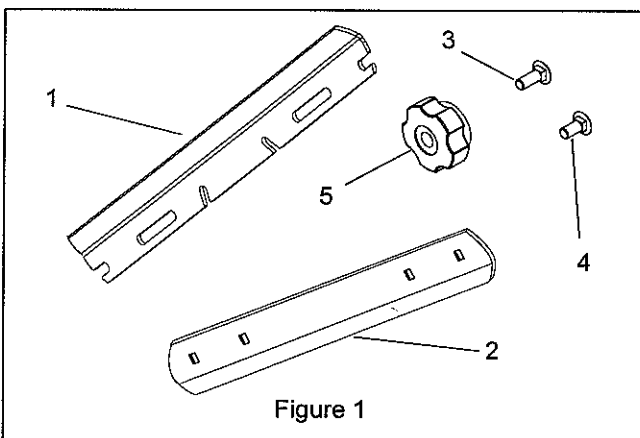

Figure 1

INSTALLATION AND OPERATION – 72406900

Installation

1. Park unit on level surface, stop engine and remove key.
2. Insert one 5/16 x 3/4" round head square neck bolt (item 3) from inside of auger housing through lower middle hole in side housing.
3. Position drift cutter (item 1) with flared edge facing the rear of the unit.

4. Install the drift cutter on the unit through the upper slot on the cutter. See Figure 2.
5. Install one clamping knob (item 5) to hold cutter in position. Do not fully tighten.
6. From inside of auger housing, install second 5/16 x 3/4" round head square neck bolt through upper hole in auger housing.
7. Install clamping knob on bolt. Do not fully tighten.
8. Slide drift cutter up so that notch in end rests against upper bolt.
9. Securely tighten hardware. Drift cutter is in storage position.
10. Repeat on other side of unit.

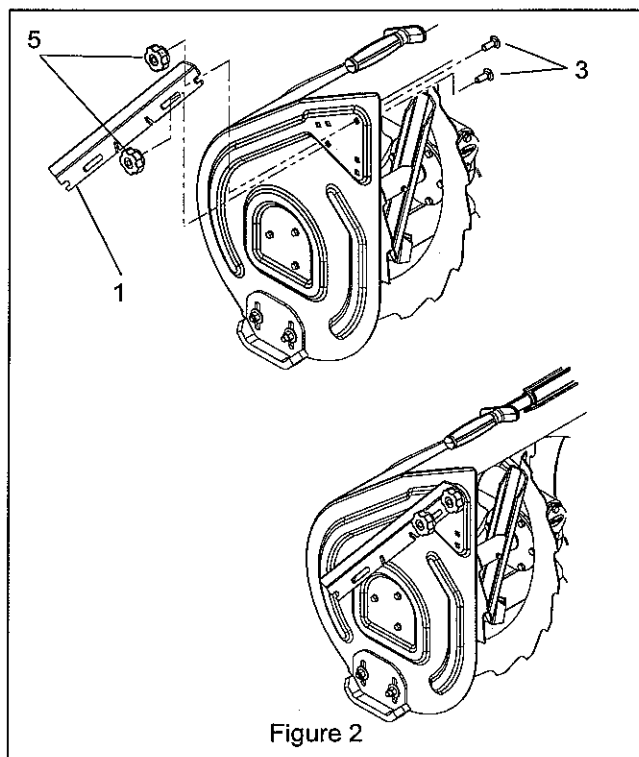
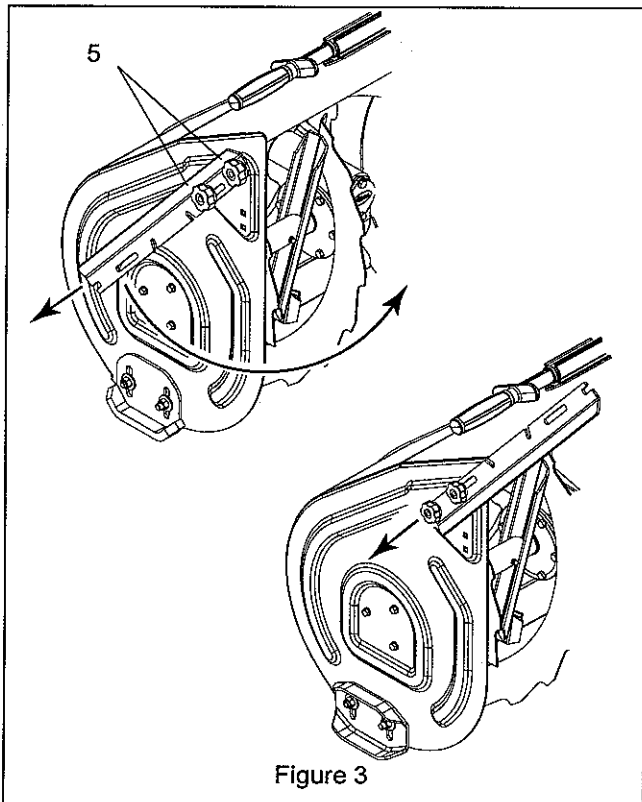

Figure 2

Drift-Cutting Position

1. To move drift cutters to drift-cutting position, loosen but do not remove clamping knobs (item 5).
2. Slide drift cutter down and to the rear of the unit.
3. Rotate drift cutter down and to the front of the unit until the notch in the side of the drift cutter securely seats on the upper bolt. See Figure 3.
4. Securely tighten clamping knobs.
5. Repeat on other side of unit.



ASSEMBLY – 73203100

1. Park unit on level surface, stop engine and remove key.
2. Insert one 5/16 x 1/2" round head square neck bolt (item 4) from inside of auger housing through upper hole in side housing.
3. Position cutter bar (item 2) with flared edge facing the front of the unit.
4. Install the cutter bar on the unit through the upper hole on the bottom of the cutter. See Figure 4.
5. Install clamping knob (item 5). Do not fully tighten.
6. From inside of auger housing, install second 5/16 x 1/2" round head square neck bolt through lower hole in housing and cutter bar.
7. Install clamping knob on bolt.
8. Securely tighten clamping knobs.
9. Repeat on other side of unit.

