

---

**Kaishan  
Rotary Screw  
Vacuum Pump**

---

**KRSV Series  
Instruction  
Manual**

---

**Direct Drive**

---

PN: xxxxxxxxxxxx

Release: May 2022, Version: A

(USA)

# TABLE OF CONTENTS

---

<b>Safety Information .....</b>	<b>4</b>
1.1 SAFETY ALERT SYMBOLS.....	4
1.2 SAFETY PRECAUTIONS .....	4
1.3 FIRE AND EXPLOSION .....	5
1.4 MOVING PARTS .....	5
1.5 HOT SURFACES .....	5
1.6 ELECTRICAL SHOCK .....	5
<b>General Information.....</b>	<b>7</b>
2.1 INTRODUCTION .....	7
2.2 OPERATING PRINCIPLE.....	9
2.3 MOTOR.....	9
2.3 VACUUM PUMP LUBRICATION AND COOLING SYSTEM.....	10
2.4 VACUUM PUMP DISCHARGE SYSTEM.....	11
2.5 AIREND, INLETVALVE AND FILTRATION SYSTEM.....	11
2.5 REGULATING SYSTEM.....	11
<b>Fluid Information .....</b>	<b>12</b>
3.1 FLUID GUIDE .....	12
3.2 FLUID CHANGE RECOMMENDATIONS .....	13
<b>Installation .....</b>	<b>14</b>
4.1 VACUUM PUMP MOUNTING, SUPPORT AND LOCATION .....	14
4.2 VENTILATION AND COOLING .....	15
4.3 PIPING CONNECTION .....	17
4.4 FLUID LEVEL INSPECTION .....	18
4.5 ELECTRICAL .....	18
4.6 MOTOR ROTATION INSPECTION.....	19
4.7 FAN ROTATION INSPECTION .....	19
<b>Vacuum pump Controller Operation.....</b>	<b>20</b>

5.1 BASIC OPERATION.....	20
5.2. PROGRAM STRUCTURE .....	22
5.3. TECHNICAL PARAMETERS .....	32
5.4. TROUBLESHOOTING .....	33
<b>Servicing .....</b>	<b>34</b>
6.1 FLUID CHANGE.....	34
6.2 AIR FILTER.....	34
6.3 FLUID FILTER.....	35
6.4 AIR/OIL SEPARATOR.....	35
6.5 FLUID SAMPLING PROCEDURE .....	35
6.6 MAINTENANCE SCHEDULE.....	36
<b>Troubleshooting Guide.....</b>	<b>37</b>
<b>Standard Terms and Conditions.....</b>	<b>39</b>
<b>Contact Information .....</b>	<b>42</b>

# Safety Information

---

Thank you for choosing the KRSV Series Vacuum Pump. Please read this instruction manual carefully before using the vacuum pump. This manual must be kept in the safe place for future reference. Kaishan USA authorized distributors provide maintenance service for KRSV series rotary screw vacuum pumps. This machine is designed for use by professionals. A certified technician is required to ensure that vacuum pump maintenance is safely handled. By following the instructions in this manual, the user will minimize the possibility of an accident throughout the useful life of this equipment.

## 1.1 SAFETY ALERT SYMBOLS

Key hazards are used throughout this manual. The level of hazards seriousness is symbolized as follows:



This symbol identifies immediate hazards which **will** result in severe personal injury, death or substantial property damage.



This symbol identifies hazards or unsafe practices which **could** result in personal injury, death or substantial property damage.



This symbol identifies immediate electrical hazards which **will** result in severe personal injury, death or substantial property damage.



This symbol identifies hazards or unsafe practices which **could** result in personal injury or substantial property damage.



This symbol identifies immediate hot surface hazards which **will** result in severe personal injury.



Identifies important installation, operation or maintenance information which is not hazard related.

## 1.2 SAFETY PRECAUTIONS

This manual describes the safety precautions, structure and functions of all systems and components, as well as the operation and maintenance methods for the KRSV series rotary screw vacuum pumps. The owner and operator shall read this manual carefully. Only after thorough understanding should the machine be operated for the first time. This manual gives you a general description of the vacuum pump, mechanical and electrical systems, and maintenance. However, if you have any questions about operating and maintenance of the vacuum pump; please contact your authorized distributor or our service department personnel.

Do not modify the vacuum pump and/or controls in any way except with written factory approval. While not specifically applicable to all types of vacuum pumps with all types of main movers, most of the precautionary statements contained herein are applicable to most vacuum pumps and the concepts behind these statements are generally applicable to all vacuum pumps.



Failure to follow any of these precautions may result in severe personal injury, death, property damage and/or vacuum pump damage

### ***1.3 FIRE AND EXPLOSION***

Clean up any spills of lubricant or combustible liquid immediately. Keep sparks and flame away from the vacuum pump. Do not permit smoking during servicing, such as checking or adding fluid. Wipe down spills immediately using industrial cleaner as required. Do not use flammable material for cleaning purposes. Do not operate the vacuum pump in a hazardous environment unless the vacuum pump has been specially designed for that environment. Wear personal protective equipment including safety goggles and clothing during servicing the vacuum pump. Never use a flammable or toxic solvent for cleaning the air filter or any parts.

### ***1.4 MOVING PARTS***

Keep hands, arms, and cloths away from the coupling and fans of the vacuum pump. Do not remove any guards or cabinet panels or attempt to service any vacuum pump part while the vacuum pump is operating.

### ***1.5 HOT SURFACES***

Do not touch any hot surface and parts during the vacuum pump's operation. Keep all body parts away from air/oil receiver tank, steel tubing, airtend and fluid-cooler. Wear personal protective equipment including gloves while servicing the vacuum pump.

### ***1.6 ELECTRICAL SHOCK***

Never start the vacuum pump unless it is safe to do so. Do not attempt to operate the vacuum pump with a known unsafe condition. Tag the vacuum pump and render it inoperative by disconnecting and locking out all power at the source or otherwise disabling its prime mover so others who may not know of the unsafe condition cannot attempt to operate it until the condition is corrected. Install, use and operate the vacuum pump only in full compliance with all pertinent OSHA regulations and/or any applicable Federal, State, and Local codes, standards and regulations. Never assume it is safe to work on the vacuum pump because it is not operating. Many installations have automatic start/stop controls and the vacuum pump may start at any time.



**NOTICE**

- Follow all maintenance procedures and check all safety devices on schedule.
- Use the correct vacuum pump fluid at all time
- Keep panels closed at all times and stay away from hot surfaces to prevent hazards



**NOTICE**

These instructions, precautions and descriptions cover KRSV series vacuum pumps. As a service to our customers, we often modify or construct packages to the customer's specifications. This manual may not be appropriate in those cases.

Every effort has been taken to ensure complete and correct instructions have been included in this manual. However, possible product updates and changes may have occurred since printing this manual. Kaishan Vacuum pump reserves the right to change specifications without incurring any obligation for equipment previously or subsequently sold.

## General Information

---

### 2.1 INTRODUCTION

The KRSV series offer models with power ranging from 10 hp to 125 hp (7.5 kw to 90 kw). KRSV are stationary, single stage, positive displacement, oil-injected rotary screw vacuum pump driven by a variable speed motor.

The vacuum pumps are equipped with Kaishan variable speed control system. This system can adjust motor speed automatically according to the vacuum level demand.

A complete package consists of following:

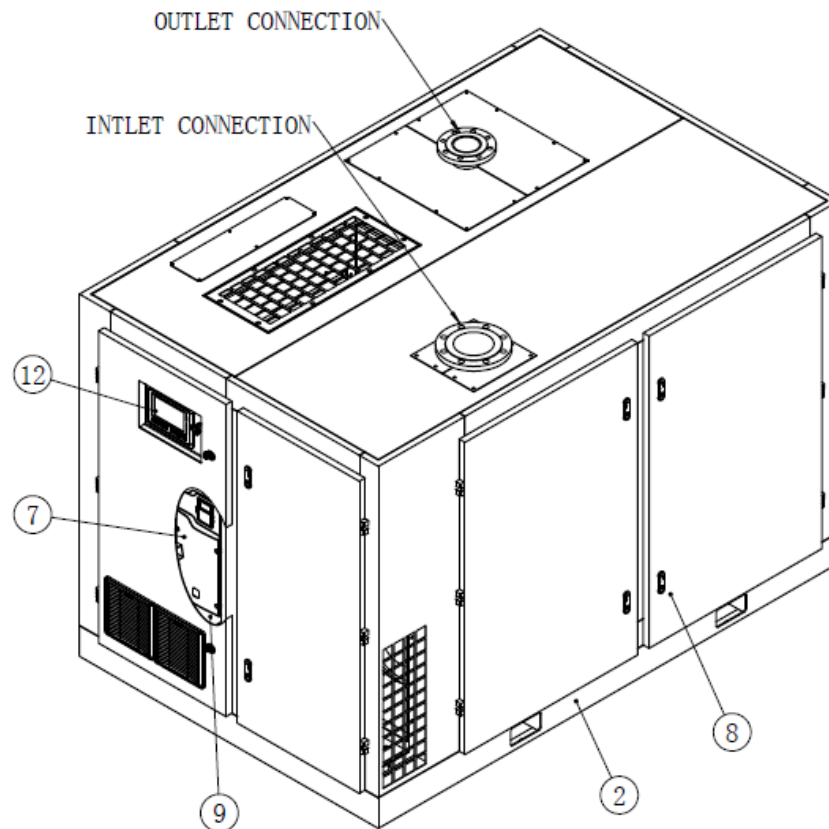

Figure 1 - The KRSV pump exterior

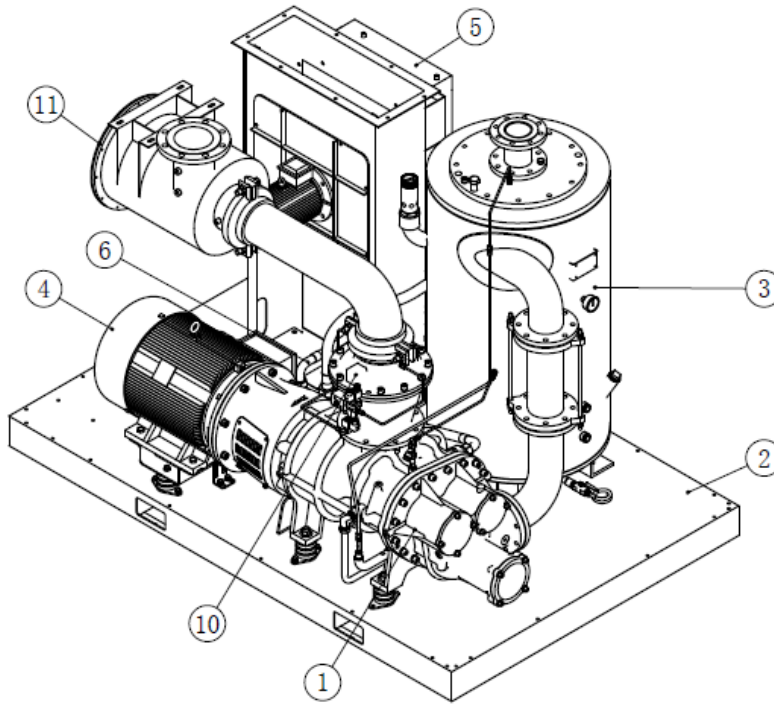

Figure 2 - The KRSV pump interior structure

- |                         |                         |
|-------------------------|-------------------------|
| 1. Vacuum Pump Airend   | 2. Base                 |
| 3. Discharge System     | 4. Pump Motor           |
| 5. Fluid Cooling System | 6. Lubrication System   |
| 7. Variable Speed Drive | 8. Acoustical Enclosure |
| 9. Electrical Enclosure | 10. Inlet valve         |
| 11. Air filter          | 12. Pump Controller     |

All components are assembled on a structural steel base with enclosure. The control panel is located in the front of the enclosure door panel. Acoustical enclosure is one of the standard features for all vacuum pumps.



Dismantling the vacuum pump's enclosure may void its warranty.

**NOTICE!**



## 2.2 OPERATING PRINCIPLE

The rotary screw oil-injected vacuum pump is a specific form of rotary positive displacement pump using a dual screw airend as the principal element in air/gas compression.

The airend housing contains of two rotors: Male and Female. The male rotor has five lobes and female rotor has six flutes. They are constantly and precisely meshed and housed in the cylinder with two parallel adjoining bores. All parts are machined to exacting tolerances. The rotors provide positive-displacement internal compression smoothly and without surging. As the rotors rotate, air is drawn into the cylinder through the inlet port. A volume of air is filled and trapped as the rotor lobes pass the inlet port in the cylinders.

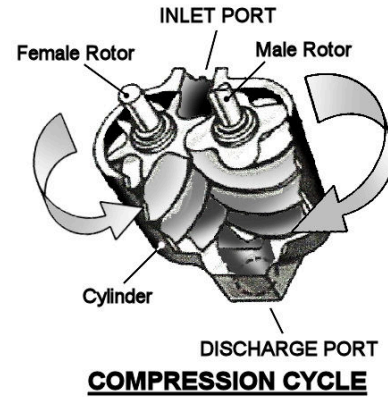

Compression occurs as the male rotor rolls into the female flute, progressively reducing the space thereby raising the pressure. Compression continues until the lobe and flute pass the discharge port. The compressed air is then discharged into the air/oil separator tank. There are five complete compression cycles for each complete rotation of the male rotor.

When the vacuum pump is operating, fluid is injected into the vacuum pump unit and mixed with the air by an external oil pump. The fluid has three basic functions:

- As a coolant, it controls the rise in air temperature normally associated with the heat of compression.
- It seals the leakage paths between the rotors and housing and between the rotors themselves.
- It acts as a lubricating film between the rotors allowing one rotor to directly drive the other, which is an idler.

After air/fluid mixture is discharged from vacuum pump to the reservoir, fluid is separated from the air in the separator tank.

## 2.3 MOTOR

The main motor is a variable speed induction motor. Operating conditions of the variable speed motor are as follows (may vary with different countries).

Ambient temperature  $\leq 40^{\circ}\text{C}$

Altitude  $\leq 1000\text{m}$

Main motor transmit power to airend through a flexible, vibration-reducing coupling. There should be no intermittent or unusual noises or vibrations when the motor is running during unload or load condition.

The voltage and frequency of power source for the motor is indicated on the nameplate, the motor can be operated continuously at the rated power  $\times$  power factor. If the frequency of the power source deviates from the rating value indicated on the nameplate by 2% of this value, or under voltage/overvoltage exceeds 10%, there can be no guarantee that the motor will deliver rated output power.

### **2.3 VACUUM PUMP LUBRICATION AND COOLING SYSTEM**

The lubrication and cooling system consist of a reservoir, oil pump, centrifugal fan, fan motor, aluminum finned fluid-cooler, thermal valve, pre-oil filter and fluid filter. The oil pump sucks fluid out through an oil prefilter from the reservoir. The fluid is then delivered to the thermal valve.

The thermal valve is a directional valve with a temperature sensitive device. The thermal valve fully closes the access to the fluid cooler when the fluid temperature is below 70°C (158°F). Fluid (below 158°F) will bypass the fluid cooler, flow through fluid filter and re-inject into the aircend. As the fluid temperature rises continually up to 80°C (176°F), due to heat of compression, the thermal valve begins to operate, and fluid will flow through the fluid cooler. Cooler fins must be kept clean at all times.

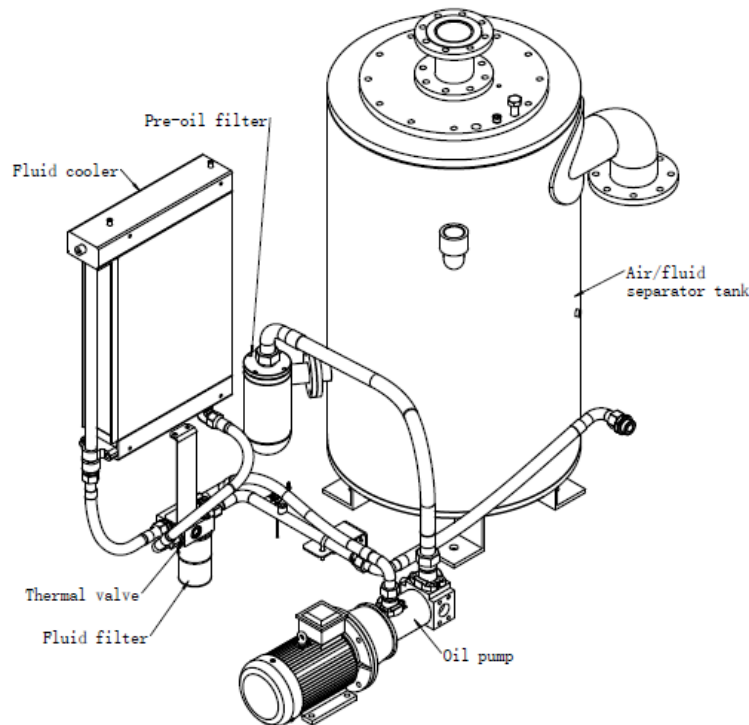

Figure 3 - Lubrication and cooling system

## ***2.4 VACUUM PUMP DISCHARGE SYSTEM***

Air/fluid mixture is discharged into reservoir after compression. The reservoir has two basic functions:

- It acts as a primary fluid separator.
- It serves as the vacuum pump fluid sump.

The compressed air/fluid mixture enters the reservoir and is directed against the internal baffle. Turbulent flow occurs, and velocity is significantly reduced, thus causing large droplets of fluid to form and fall to the bottom of reservoir. Fluid collected in the reservoir will then be returned to the vacuum pump due to the pressure differential.

The sight glass enables the operator to visually monitor the reservoir fluid level. Fluid is added to the reservoir by removing the fluid filling cap after all system pressure is relieved. The fluid level should remain at the top red line on the sight glass. Fluid refill is required once its level drops below the lower red line.

## ***2.5 AIREND, INLETVALVE AND FILTRATION SYSTEM***

The vacuum pump inlet system consists of an air filter, inlet valve and airend. Air filter is capable of cleaning dirty air. Air is drawn through the air filter and inlet valve, into the airend where it is compressed. The inlet valve controls the air intake volume. It also acts as a check valve to prevent reverse pressure and rotation when vacuum pump is shutting down.

## ***2.5 REGULATING SYSTEM***

The vacuum pump regulating system consists of an inlet valve, pressure sensor, variable speed drive and two solenoid valves.

The inlet valve is fully open during loading. Pressure sensor measures intake pressure, pressure can reflect the process vacuum demand. When the pressure is lower than the target point, the variable speed drive decreases the motor speed.

When the motor operates at minimum speed and inlet pressure is still lower than the minimum set pressure, the solenoid valves are energized to close the inlet valve, the vacuum pump turns to the unloading running state. Upon reaching the set duration in unloading status, the machine stops automatically. The machine will load again if vacuum pressure reaches the set point during unloading.

## Fluid Information

### 3.1 FLUID GUIDE

KRSV vacuum pumps are filled & tested with Kaishan lubricant. Refer Figure 4 for filler port, sight glass, drain valve and vacuum gauge location on the reservoir. The vacuum pump is filled with the manufacturer's recommended quantity of Kaishan fluid. Inspection of the reservoir fluid level during installation or operation is recommended.

①	Vacuum Gauge
②	Air/Oil Separator Tank
③	Fluid Fill Port
④	Sight Glass - High Level
⑤	Sight Glass - Low Level
⑥	Fluid Drain Valve

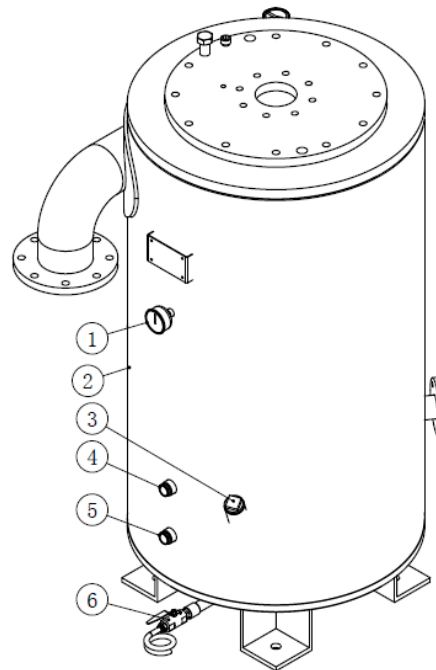

Figure 4 - Fluid Fill Location



Do not use different fluid. Using different fluid will void vacuum pump's warranty.

### **3.2 FLUID CHANGE RECOMMENDATIONS**

The fluids as shown in the table below can be used in the KRSV vacuum pump.

<b>LUBRICANT TYPE</b>	<b>CHANGE FLUID PERIOD</b>	<b>Remark</b>
KTL8000	Every 8,000 hours, or as indicated by sampling report	Standard factory fill fluid Sampling every 2000 hours is required
KTL-8000PG-S	Every 8,000 hours, or as indicated by sampling report	For high humidity applications, For high tropical applications Sampling every 2000 hours is required
KTL-4000FG	Every 4,000 hours, or as indicated by sampling report	FDA & NSF approved Halal certified

## Installation

---

### ***4.1 VACUUM PUMP MOUNTING, SUPPORT AND LOCATION***

The vacuum pump is designed for indoor use. If the unit is installed outdoors, special precautions must be taken, consult your supplier for support. The installation site shall have low relative humidity, clean air and good ventilation, without corrosion or metal chippings.

The vacuum pump should be located on a flat surface in a clean, well-ventilated area. The location must have sufficient access for maintenance equipment and lifting vehicle. Four feet (4') of clearance around the vacuum pump is recommended for daily inspection and easy access to all vacuum pump components. The area must have sufficient lighting for technicians to safely operate the vacuum pump as well as perform maintenance work. The location should be free of standing water.

The vacuum pump's base must be installed on a level surface that can support the gross dead weight of the machine. Rubber pads within 5 - 15mm thickness or pliable material should be placed under the bottom of the base if floor surface is uneven or irregular.

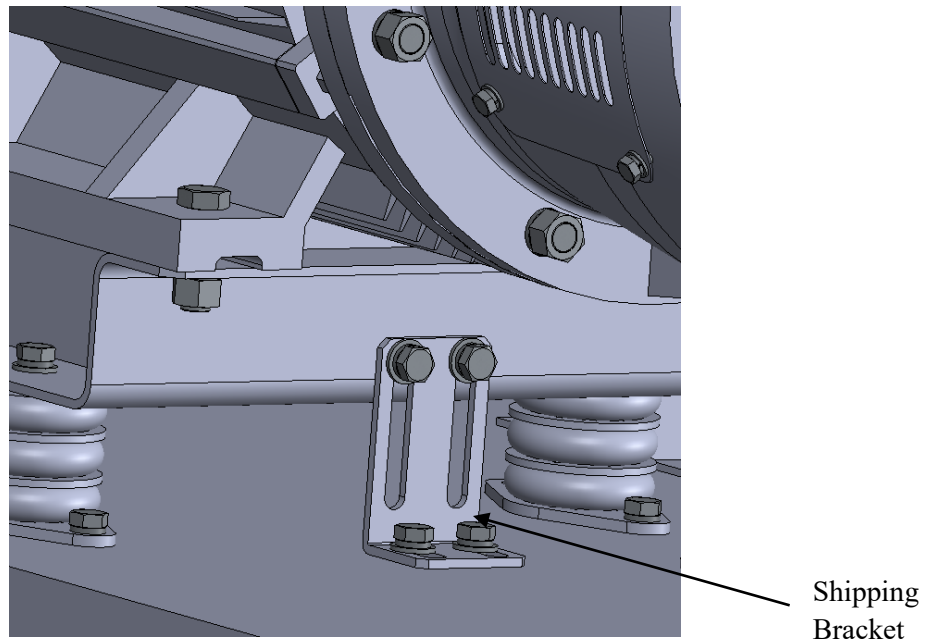

Figure 5 - Shipping Bracket



Brand new vacuum pump has “Orange Color” shipping bracket installed under motor. Please remove the bracket after the unit is installed.

#### **NOTICE!**



Removal or paint over safety labels will be a safety hazard. This could result in personal injury or property damage. Warning signs and labels should be conspicuous and on a bright legible surface. Do not remove any warning, caution or instructional material attached to the unit.

#### **4.2 VENTILATION AND COOLING**

Ambient temperature should not exceed 40°C (104°F). High ambient temperatures may result in high discharge temperature shutdown.



**NOTICE!**

Vacuum pump must be equipped with high-ambient option if operating temperature exceeds 40°C (104°F).



**NOTICE!**

Do not install and operate vacuum pump if the ambient temperature is below 1°C (34°F). Pre-heat option must be installed with the unit for lower ambient temperatures.

The vacuum pump air inlet must be located in the opposite direction to other vacuum pumps or heat generating equipment, to avoid hot air being drawn into the system. Do not block the exhaust air from cooler or fan.

If vacuum pump is installed in an enclosed room, an exhaust fan must be installed to exhaust the hot air to the outside. The vacuum pump room must be properly ventilated to avoid vacuum pump high temperature shutdown.

The pressure loss across all externally connected ductwork should not exceed 7mm water gauge in total, otherwise should add an extra ventilation fan which air flow shall not be lower than that stipulated in the following table.

<b>Pump Motor Power kW</b>	<b>Cooling Air Flow Rate m<sup>3</sup>/min</b>	<b>Maximum Duct Pressure Drop Pa(mmH<sub>2</sub>O)</b>
18.5-22	78	70 (7)
30-37	135	70 (7)
45-55	185	70 (7)
75-90	295	70 (7)

When fixing the ducting to the vacuum pump exhaust, make sure there is a small section in place in case the vacuum pump unit needs to be removed. In this way the whole ductwork can remain in position.

Hot air can be a source for heat recovery and/or be used to keep the vacuum pump room warm in winter. Consider diverters and side vents during the design stages.

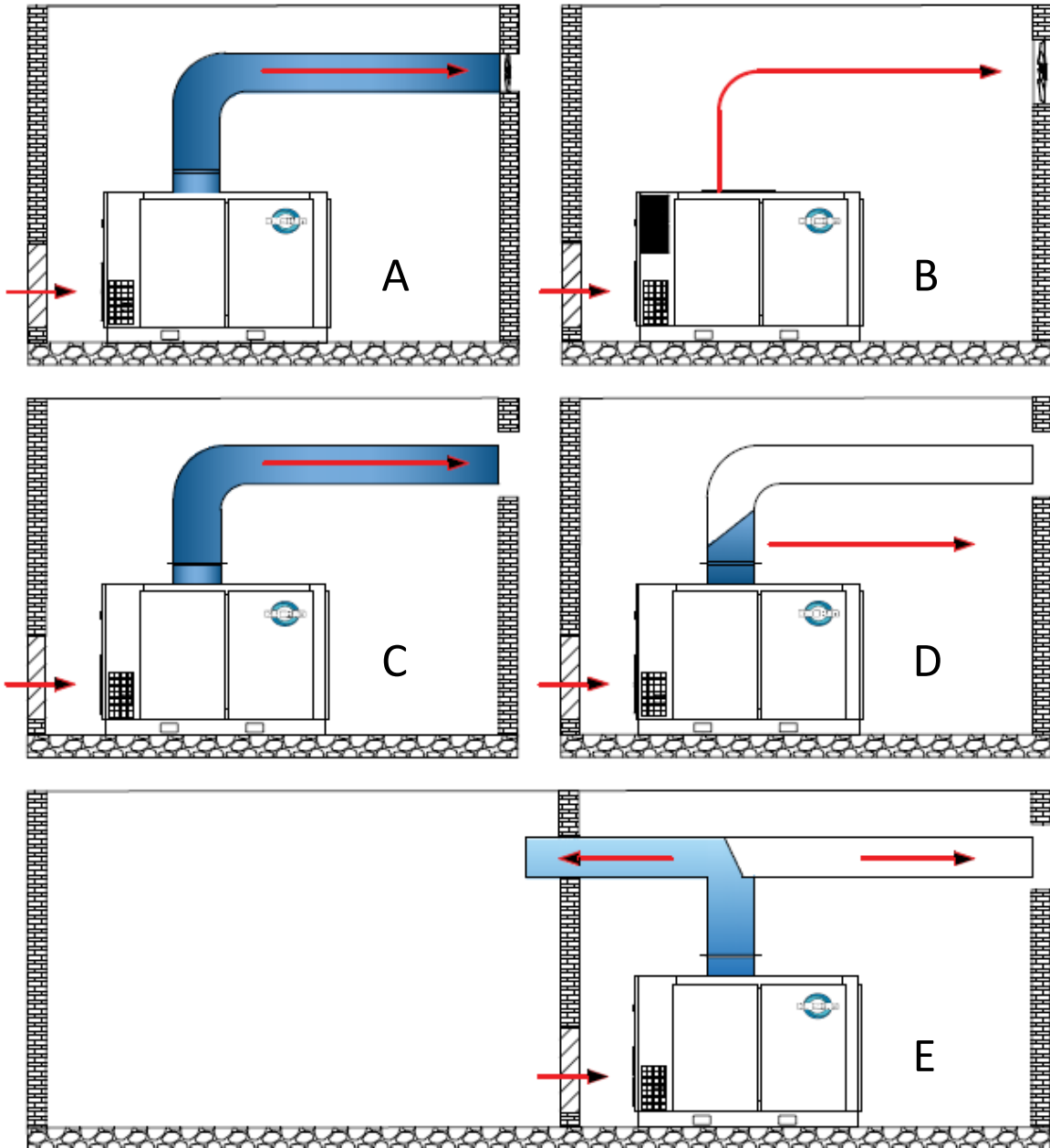

Figure 6 - Vacuum pump room



A; Supply and Exhaust in outside walls

B; Extractor Fan assisted

C; Exhaust Air straight to outside

D; Recirculation flap for winter

E; Heat Recovery or to outside



Maintain clean & fresh air, dust free, metal particle free and chemical vapor free in the vacuum pump's room. Housing the vacuum pump within a poorly ventilated enclosure will cause higher operating temperature.



Under no circumstances should a vacuum pump be installed in an area exposed to toxic, volatile or corrosive atmosphere, nor should toxic, volatile or corrosive agents be stored near the vacuum pump.

All models are intended for indoor installation; however, it is possible, with certain modifications, to accommodate some outdoor locations. Models with standard enclosure are water-resistant but not watertight. Shelter is needed to protect the unit from rain, snow, and freezing temperatures. An optional weather hood or air grille could be installed to protect vacuum pump against blowing rain and snow as well as cabinet heater additions if ambient temperature will be below 0°C (32 F).

### ***4.3 PIPING CONNECTION***

Before installation, review the complete air systems layout, which includes vacuum pump(s) and all related components. Never use PVC pipe or non-genuine rubber hose in the vacuum distribution system. Use flexible connections to prevent pipe load from being transmitted to the vacuum pump. It is very important to use adequate pipe diameter for the vacuum network, pipe size specified by the manufacturer for the vacuum pump unit is recommended.

A service line shut off valve shall be installed before the vacuum pump air inlet connection, this will allow unit isolation for maintenance. For a single vacuum pump, a manual shut off valve is typically being installed.



The discharge air can run up to 110 °C (230 °F).

Service line piping is recommended to be sized to match the vacuum pump's discharge connector. Isolation valves & drain valves are installed to isolate the vacuum pump when service is required. These valves should have water drip legs with the drain direction facing downward to the floor. Piping should all line up properly with an adequate loop radius or bend radius given

for easy installation and to prevent bending stress, flow restriction and damage due to thermal expansion. Piping support brackets must be mounted independent of the vacuum pump and motor. This will avoid damage caused by vibration.

#### ***4.4 FLUID LEVEL INSPECTION***

Inspect the fluid level when the vacuum pump is in shut down mode to make sure fluid has not leaked from the unit during transportation. Fluid level is indicated on the reservoir sight glass. When the vacuum pump is running, the level should not exceed the upper sight glass.

Regularly check the oil level during operation.

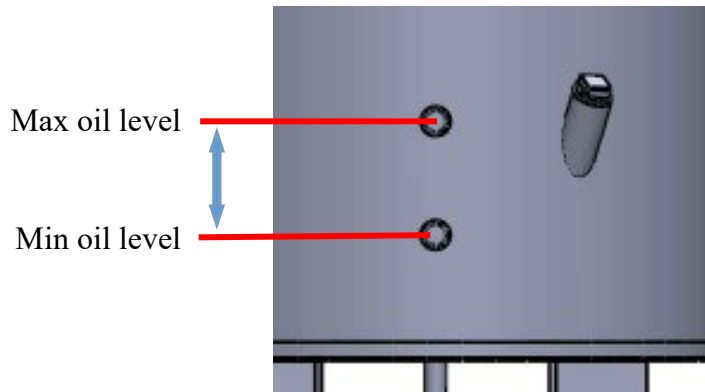

Figure 7 – Sight glass

#### ***4.5 ELECTRICAL***

Before installation, the electrical supply should be checked for adequate wire size and capacity. User must comply with national & local electrical codes. The codes specify the surrounding clearance requirement for the electrical panel. Wiring work should be undertaken only by a qualified electrician in compliance with OSHA, and national or local electrical code. KRSV vacuum pumps provide wiring diagrams for user reference. Refer to the electrical control schematic in the parts manual for wiring diagrams. A dedicated and fused disconnect switch or circuit breaker should be purchased for the installation. Any unreasonable voltage imbalance (5%) between phases must be eliminated and low voltage problems must be corrected to prevent excessive current draw. Vacuum pumps must be grounded in accordance with applicable codes and regulations.



Kaishan would like to emphasize the importance of providing adequate grounding for vacuum pumps. The common practice of grounding units to a building's structural steel may not provide adequate grounding protection, as paint and corrosion build-up may exist.



All electrical supply cables must be adequately sized to prevent overheating due to current draw.





Enclosure panels and drive grille must be fastened in place before starting the vacuum pump and never removed before lock out / tag out of the main power supply.

A knock out is provided for incoming power connection. If a different location for the starter hole is needed, the certified technician must make sure to keep control box clean after the hole is created. The original hole must be capped if another hole is used. Inspect incoming voltage to match the vacuum pump's specification. Inspect motor starter and overload heater sizes. Check all electrical connections L1-L2-L3 for tightness and cleanliness.

#### ***4.6 MOTOR ROTATION INSPECTION***

Motor rotation must be checked after the wiring has been installed. Operating the vacuum pump in the incorrect rotation will result in severe damage to the vacuum pump and warranty coverage will be voided. Motor rotation can be viewed through the opening in the drive grille. The drive motor end of the vacuum pump is marked with an arrow noting the proper rotation.



To inspect rotors rotation, pull out the EMERGENCY STOP  button, quickly press the START  and STOP  button in sequence, allowing the motor to turn 2 or 3 revolutions. Observe the drive shaft for correct direction. If reverse rotation is observed, disconnect the power supply, reverse power input leads at the motor starter. Recheck for proper rotation.

#### ***4.7 FAN ROTATION INSPECTION***

Fan motor rotation should be inspected. KRSV vacuum pumps uses a centrifugal fan for cooling. Fan rotation is inspected through an arrow shaped observation hole above the fan motor. The fan must rotate in the direction indicated by the arrow.



**NOTICE!**

Always inspect fan rotation through the observation hole. Never assume the fan rotation is correct based on the induced air flow across the coolers. A centrifugal fan can pull the airflow across the coolers when rotating in either direction; however, incorrect rotation will cause high discharge temperature.

# Vacuum pump Controller Operation

## 5.1 BASIC OPERATION

### 5.1.1. Screen display and basic operation

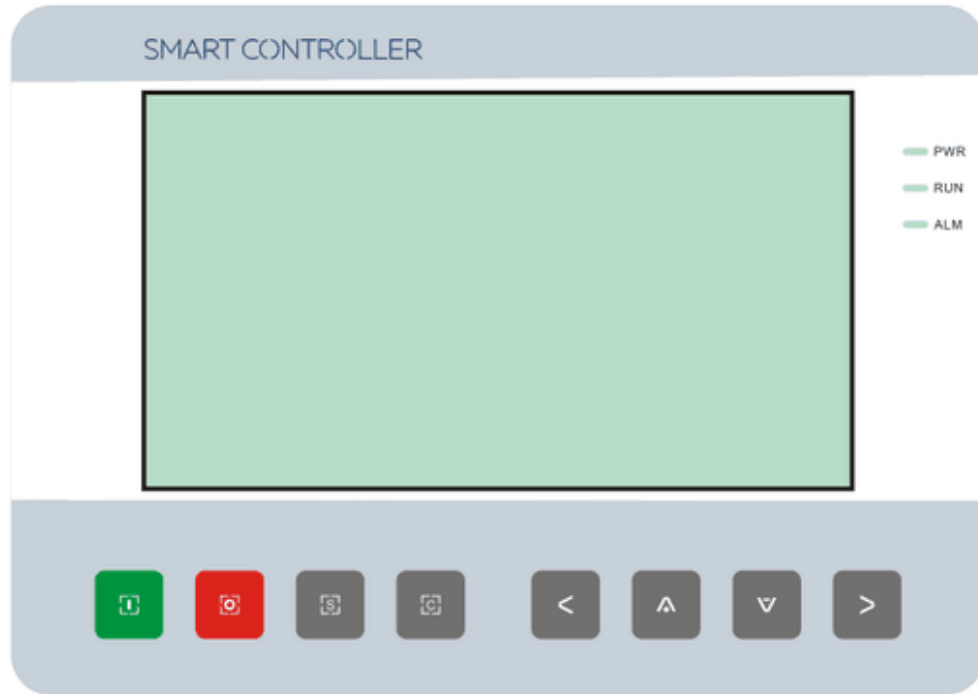
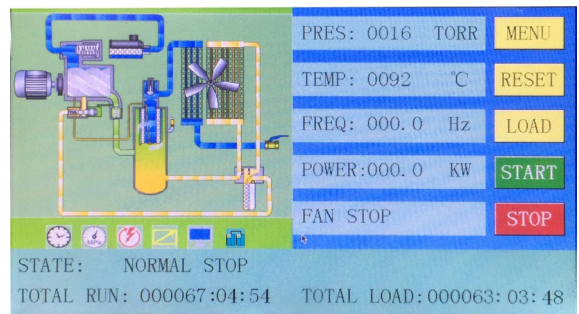

Figure 8 – Control panel

Power up screen:



Boot up screen, after 5 seconds:



## ***Controller LED indication***

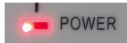

Power: Is on when controller is powered on.

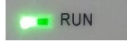

Run: Is on when motor is running.

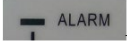

Alarm: Is blinking when vacuum pump is alarmed. Is on when vacuum pump is alarmed and stopped. Is off when errors have been cleared and reset.

### ***5.1.2 Button functionality***



Press to Start Vacuum pump.

When in Sequence Mode and Master Vacuum pump, press to activate the Sequence Mode.



Press to Stop Vacuum pump.

When in Sequence Mode and Master Vacuum pump, press to de-activate the Sequence Mode.



Press to Load and Unload vacuum pump when in running state.

Press to save data when modifying text box.

When on Icons Page, Press to execute the corresponding function.



When Controller is in Alarm, press and hold for 5 seconds to Reset.

Press this button to allow data in textbox to be modified.

Press to return to previous menu.



Moves the cursor to the left.

On Icons page, press to move to the next Icon.



Moves the cursor to the right.

When on the Icons page, press to move to the previous Icon.



When on Icons page, press to move down to the next row.

When modifying values press to decrease.

When viewing RUN data press to scroll down to the next page.



When on Icons page, press to move up to the next row.

When modifying values press to increase.

When viewing RUN data press to scroll up a page.

### 5.1.3 Icons display and functions

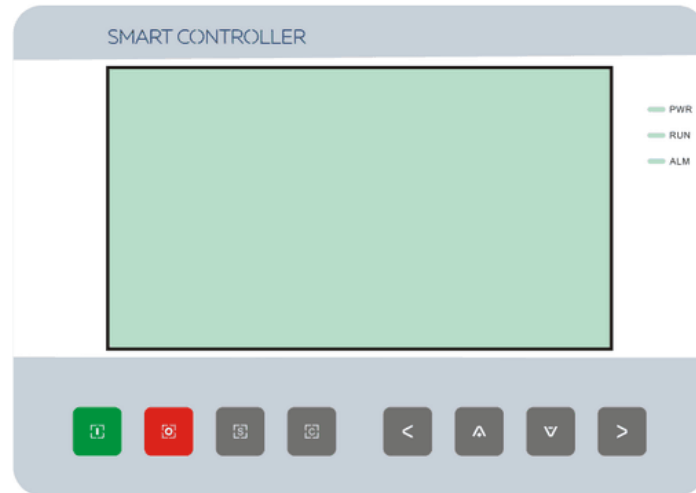

If activated, the following Icons will appear on the Normal Run Screen:



A Time Schedule has been set.



A Pressure Schedule has been set.



Auto Restart is engaged.



Remote Stop/Start activated.



Computer Visualization set.



Multi-Unit Sequence Control activated.

## 5.2. PROGRAM STRUCTURE

Controller has 14 specific data zones, each zone is password protected.

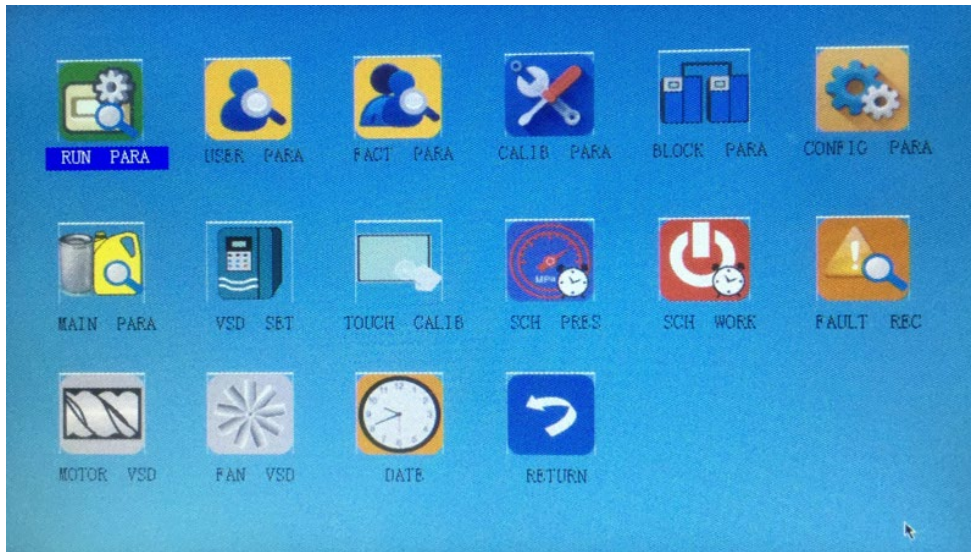
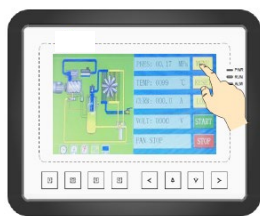

Figure 9 – Controller menu

Other than RUN, MAINTENANCE and USER PASSWORDS, only authorized and trained personnel should have access to other specific zones.

FUNCTION	PASSWORD
RUN	NO PASSWORD REQUIRED
USER	9999
MAINTENANCE	6842

### 5.2.1 Run menu



Press menu



Press RUN PARA

Enter “RUN PARAMETER” menu to check the relative data and set.

MENU	FUNCTION
INLET P	Display inlet air pressure
DISC T	Display discharge temperature

MENU	FUNCTION
SYSTEM P	Display system pressure
INJECTION P	Display oil injection pressure, if applicable
OIL PRES DIFF	Display oil pressure differential in running mode
FRONT ROTOR T	Display front rotor temperature, if applicable
REAR ROTOR T	Display rear rotor temperature, if applicable
OIL FILTER	Record total running time of oil filter.
O/A SEPERATOR	Record total running time of O/A separator
AIR FILTER	Record total running time of air filter
LUBE	Record total running time of lubricant
GREASE	Record total running time of grease
SERIAL NO.	
POWER SOURCE VOLTAGE	Display power source voltage
MOTOR CURRENT	Display motor current
FAN CURRENT	Display fan current
MOTOR RATED SPEED	Display motor actual speed based on the calculation for motor frequency reading
MOTOR RATED POWER	Display the output frequency of current motor inverter
MOTOR OUTPUT CURRENT	Display the output current of current motor inverter
MOTOR OUTPUT VOLTAGE	Display the output voltage of current motor inverter
MOTOR OUTPUT POWER	Display the output power of current motor inverter
MOTOR THIS POWER CONSUMPTION	Display the accumulative this power consumption based on the motor inverter real time output power
MOTOR TOTAL POWER CONSUMPTION	Display the accumulative total power consumption based on the motor inverter real time output power
PRESSURE	
MOTOR STATE DISCRPTION	Display in the controller motor status area based on the running status register data reads from motor inverter
ERROR DISCRPTION	Display in the controller error area based on the running error register data read from motor inverter
WRITE FREQUENCY	Display the motor frequency based on PID calculation
PRODUCTION DATE	
THIS RUN TIME	Record compressor this run time
THIS LOAD TIME	Record compressor this load time
SOFTWARE EDITION:	
CHECK	



MENU	FUNCTION
INPUT STATE:	<p>1 2 3 4 5 6 7 8 9 10</p> <p>● ● ● ● ● ● ● ● ● ● ●</p> <p>1: In accordance with No.24 digital input state  2: In accordance with No.23 digital input state  3: In accordance with No.22 digital input state  4: In accordance with No.21 digital input state  5: In accordance with No.20 digital input state  6: In accordance with No.19 digital input state  7: In accordance with No.18digital input state  8: In accordance with No.17 digital input state</p> <p>Red circle of input state means terminal is connected;  Light-red circle of input state means terminal is disconnected</p>
OUTPUT STATE:	<p>1 2 3 4 5 6 7 8 9 10</p> <p>● ● ● ● ● ● ● ● ● ● ●</p> <p>1: In accordance with No.43 digital output state  2: In accordance with No.42 digital output state  3: In accordance with No.41 digital output state  4: In accordance with No.40 digital output state  5: In accordance with No.39 digital output state  6: In accordance with No.37 digital output state  7: In accordance with No.36 digital output state  8: In accordance with No.33 digital output state  9: In accordance with No.32 digital output state  10: In accordance with No.31 digital output state</p> <p>Red circle of input state means terminal is connected  Light-red circle of input state means terminal is disconnected</p>
PF MOTOR U*I:	Display real time motor current* voltage
PF MOTOR THIS POWER CONSUMPTION:	When set as PF, display the compressor this time power consumption (FYI)
PF MOTOR TOTAL POWER CONSUMPTION:	When set as PF, display the motor total power consumption (FYI)
PF FAN U*I:	Display real time fan current* voltage
PF FAN THIS POWER CONSUMPTION:	When set as FAN PF, display the fan this time power consumption (FYI)
PF FAN TOTAL POWER CONSUMPTION:	When set as FAN PF, display the fan total power consumption (FYI)

## 5.2.2 User menu

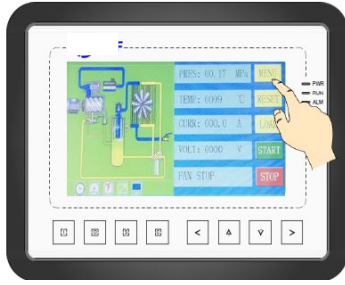

Press MENU



Press USER PARA

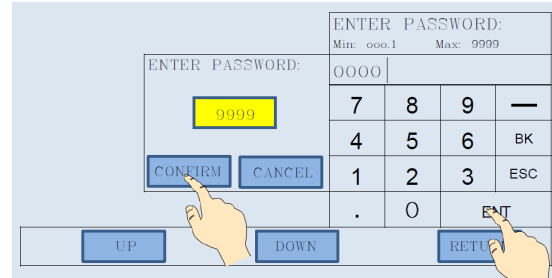
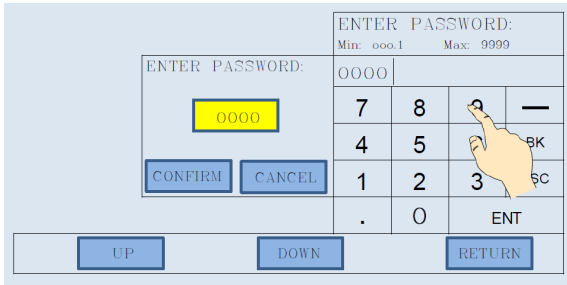

Enter the User password, press Enter and Confirm.

Menu	Pre-set Data	Function
MIN PRES(TORR)	0380	
MAX PRES(TORR)	0760	
FAN START T(°C)	0080	Fan will start if DISC T is above this set data
FAN STOP T(°C)	0070	Fan will stop if DISC T is below this set data
MOTOR START DELAY(S)	0008	Set the MOTOR START TIME. Record time when motor is activated, controller will not start overload protection during this time to avoid impulse starting current stopping the motor.
FAN START DELAY(S):	0003	Set the FAN START TIME. Record time when fan is activated, controller will not start overload protection during this time to avoid impulse starting current stopping the fan.
STAR DELAY(S):	0006	Interval time from star start to delta start.
LOAD DELAY(S):	0002	Unloading in this set time after enter delta running
STANDBY DELAY(S):	0600	When unloading continuously, VP will automatically stop and enter to standby status if over this set time

Menu	Preset Data	Function
STOP DELAY(S):	0010	For NORMAL STOP operation, VP will stop after it continuously unloads over this set time
RESTART DELAY(S):	0100	Machine can start only over this set time at any case (after normal stop, standby or alarm & stop)
DRAIN OPEN TIME(S):	0002	Auto drain control, continuously drain time
DRAIN CLOSE TIME(M):	0060	Auto drain control, continuously drain interval time
SOFT START DELAY(S):	0006	Controller starts LOAD DELAY TIME after SOFT-START DELAY (this data is only available in SOFT START mode)
LOAD MODE:	MANUAL/ AUTOMATIC	MANUAL : only when the pressure is above UNLD P, VP will unload automatically. For any other case , the Load/Unload function can only be executed by pressing “load/unload” key AUTOMATIC: the load/unload function can be executed by the fluctuation of AIR P automatically
START MODE:	LOCAL/ REMOTE	LOCAL: only the button on the controller can turn on and turn off the machine REMOTE: both the button on the controller and the remote control button can turn on and turn off the machine Note: When one input terminal is set as REMOTE START ENABLE, start mode is controlled by hardware status. It is on remote when terminal is close, it is on local when terminal is open In this case, the set here is not available
RUN MODE:	PF/MOTOR VSD/FAN VSD/MOTOR FAN VSD/SOFT START	Choose the corresponding VP run mode according to customer requirement and choose the corresponding schematic diagram for reference
COM ADD:	0001	Set the communication address in COMPUTER or BLOCK mode. This address is unique for every controller in net

Menu	Preset Data	Function
BACKLIGHT ADJUSTMENT:	0001	Adjust the backlight, the higher the data, the brighter the display (from level 1 to level 4)
COM MODE:	COMPUTER/BLOCK/DISABLE	DISABLE: communication function is not activated. COMPUTER: compressor can communicate with computer or DCS as slave according to MODBUS-RTU. Baud rate:9600; Data format:8N1; Parity bit: even parity check BLOCK: compressors can work in a net
PRESSURE UNIT:	MPa/PSI/BAR	MPa: Pressure unit displays as MPa PSI: Pressure unit displays as PSI BAR: Pressure unit displays as BAR
TEMPERATURE UNIT:	°C/°F	°C: Temperature unit displays as °C °F: Temperature unit is displays as °F
LANGUAGE:	CHINESE/ENGLISH	ENGLISH: Displays in English CHINESE: Displays in Chinese
USER PASSWORD:	****	User could modify the user password by old user password or factory password
SLEEP BACKLIGHT:	0000	Adjust the backlight when no operation in a long time
INJECTION OIL PROT DELAY(S):	0010	Checks if the injection oil P is higher than the set pressure stop value after start delay lasts for this time; then alarm and stop. Check if the injection oil P is lower than the set pressure stop value after start delay lasts for this time; then alarm and stop.
INJECTION OIL PRES HIGH ALARM DELAY(S):	0016	Checks if the injection oil P is higher than the set pressure value after start delay lasts for this time; then alarm
INJECTION OIL PRES LOW ALARM DELAY(S):	0016	Checks if the injection oil P is lower than the set pressure value after start delay lasts for this time; then alarm.
MOTOR VF PRES(TORR)	0150	@VF MODE, Controller checks the inlet P, then makes the inlet P close to the set value through control motor speed by PID parameter

To change a setting:

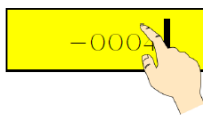
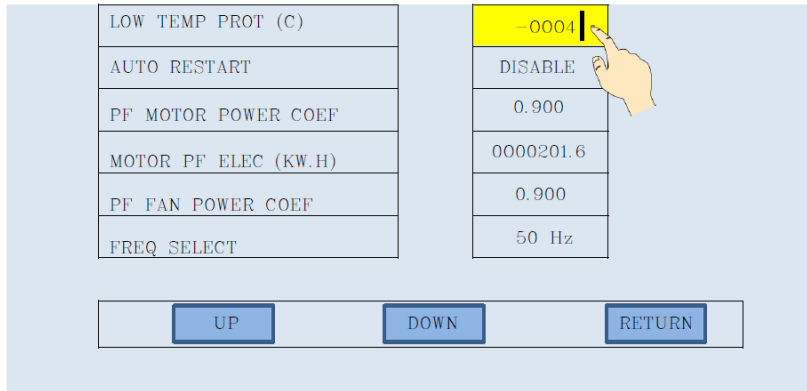

Highlight text to be modified



Press C to allow data modification – text will start flashing



Scroll values up or down



Press S to set

### 5.2.5 Sequencing parameters

Press MENU, Press BLOCK PARA, enter the User password, press Enter and Confirm.

MAM 6090 has the capacity to control 16 vacuum pumps via a daisy chain RS485 series link utilizing RS485-1 terminals A1, B1 and GND1.

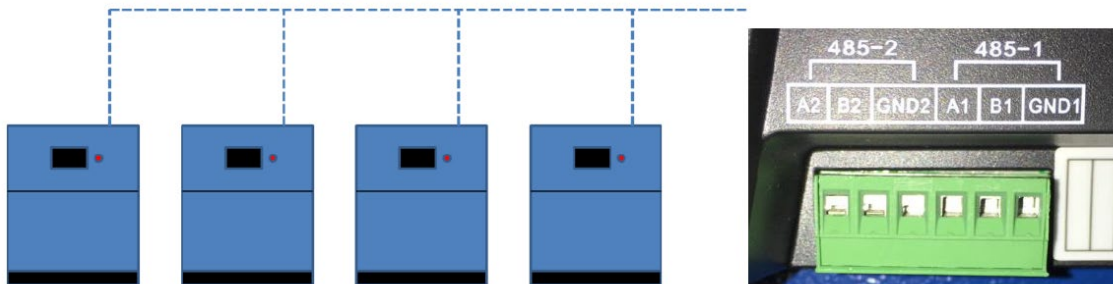

MENU	FUNCTION
Block Number	Number of Vacuum pumps to Sequence.
Block Load Pressure (Mpa/PSI)	In Sequence Mode, one vacuum pump will Start and load when master air pressure is below this set data.
Block Unload Pressure (Mpa/PSI)	In Sequence Mode, one vacuum pump will Stop or unload when master air pressure is above this set data.
Block Delay (S)	Delay to start and load more than one vacuum pump.
Turn Time (M)	Time to change over Master and Slave vacuum pump.
Block Mode	All VSD's

To Set Master Control Vacuum pump:

- a) Go to User Menu,
- b) Set COMM MODE to BLOCK
- c) Set COM ADD to 0001 for Master Unit
- d) After setting, turn off Controller and Reboot to save this setting.

To Set Slave Vacuum pumps:

- a) Go to User Menu
- b) Set COMMS MODE to BLOCK
- c) Set COM ADD to 0002 - 16 for Slave Units
- d) The Sequence BLOCK Icon will appear on the Controller Screen

To Start / Stop Sequence BLOCK MODE:

- a) To activate BLOCK MODE start Master vacuum pump first.
- b) Start each of the Slave units in turn.
- c) Allow the Vacuum pumps to Start and Stop themselves according to the settings already programmed.
- d) Stopping the Master vacuum pump manually will deactivate the BLOCK Control.

Network Connection:

The MAM 6090 Controller supports MODBUS RTU protocol.

It supports 03, 06, 16 MODBUS commands.

Communication baud rate 9600 BPS

1 Start bit

8 Data bits

1 Stop bit

Even Parity

### 5.2.7 Maintenance parameters

Press MENU, press MAIN PARA, enter the password, press Enter and Confirm.

MENU	DEFAULT VALUE	FUNCTION
Oil Filter Run Time (H)	0000	Service of Oil Filter Real Time. When replacing oil filter it has to be manually reset.
Air/Oil Separator Run Time (H)	0000	Service of Separator Element Real Time. When replacing separator it has to be manually reset.
Air Filter Run Time (H)	0000	Service of Air Filter Real Time. When replacing air filter it has to be manually reset.
Lubricant Run Time (H)	0000	Service of Lubricant Real Time. When replacing oil it has to be manually reset.
Grease Run Time (H)	0000	Service of Grease Real Time. When greasing it has to be manually reset.
Oil Filter Max Run Time (H)	2000	Alarm Prompt Hours. Set to 0000 and function is disabled
Air/Oil Separator Max Run Time (H)	2000	Alarm Prompt Hours. Set to 0000 and function is disabled
Air Filter Max Run Time (H)	2000	Alarm Prompt Hours. Set to 0000 and function is disabled
Lubricant Max Run Time (H)	2000	Alarm Prompt Hours. Set to 0000 and function is disabled
Grease Max Run Time (H)	2000	Alarm Prompt Hours. Set to 0000 and function is disabled

The following alarms will occur from this maintenance menu if set parameters are exceeded:

ALARM	MESSAGE
Air filter alarm	AIR BLOCK
	AIR TIME END
Oil filter alarm	OIL BLOCK
	OIL TIME END
Separator alarm	O/A BLOCK
	O/A TIME END
Lubricant alarm	LUBE TIME END
Grease alarm	GREASE TIME END

### **5.2.9 Touch screen calibration**

Touch calibration is used to adjust touch accuracy.

Press MENU, press TOUCH CALIB, enter the password, press Enter and Confirm.

After entering touch calibration menu, use fingertip to click A, B, C, D in sequence. Press “S” button to restart and save the modification.

### **5.2.10 Scheduled pressure**

Scheduled On-Off is used to set one week scheduled on-off time, four period is allowed to set in one day. Scheduled On-Off password is required for check and modification. Main function is below. When set to 00:00, the correspondent function is invalid.

### **5.2.12 History record**

Select FAULT REC. Stores 100 faults in history file. Can be Reset in Factory Menu.

### **5.2.15 Date and Time**

Select DATE. Set real time and date.

## **5.3. TECHNICAL PARAMETERS**

1. Ambient: -20 ~ 60°C (-4 ~ 140°F), Humidity  $\leq$ 98%
2. Digital Inputs: 8.
3. Digital Output relays: 10 (250VAC ~ 5A capacity).
4. Analog Inputs: 3 x PT100.
5. Transducer Inputs: 2 x 4-20ma.
6. CTs Input: 2 x 3 phase groups.
7. Voltage Options: 460 / 400 / 220 VAC.
8. Controller Power Supply: 16-28VAC, 20VA.
9. RTD Range: -50 ~ 350 °C (-58 ~ 284°F), Accuracy:  $\pm$ 1°C
10. Running Time: 0 ~ 999999 hours
11. Current: 0 ~ 999.9 A
12. Pressure Transducer: 0 ~ 16 bar (0~232PSI), 4-20mA, 28VDC.
13. RS485 port 1: For Sequence or Computer communication.
14. RS 485 port 2: For Inverter control.
15. Phase reversal protection response time  $\leq$  1 s.
16. High temperature response time  $\leq$  2 s.



#### 5.4. TROUBLESHOOTING

FAULT	PROBABLE REASON	REMEDY
High discharge temperature	lubricant is insufficient.	Check add top up lubricant
	Incorrect grade of lubricant	Check and replace lubricant
	High ambient temperature	Improve ventilation to cool down room temperature
	Oil filter clogged	Replace oil filter
	Oil cooler clogged	Clean cooler
	Accumulated dusts on cooler surfaces	Clean cooler fins
	Ventilation duct clogged	Check for cooling air restriction or increase the duct size. Clean duct.
	Failure of temperature sensor	Replace temperature sensor Check and repair
Temperature Sensor Failure	Cable broken or PT100 failure	Check the wiring and PT100.
High Pressure	Pressure too high or pressure sensor failure	Check the pressure and the pressure sensor.
Pressure Sensor Failure	Cable broken, Sensor failure or the cables connected reversely	Check the wiring and pressure transmitter.
Open Phase	Power open phase or contactor failure	Check the power and contactors.
Overload	Voltage too low, tubes blocked, bearing wear off or other mechanical failure or wrong set data etc.	Check the set data, voltage, bearings, tubes and other mechanical systems.
Unbalance	Current unbalance, contactor failure or internal open loop on the motor	Check the power, contactors, and the motor.
Wrong Phase Sequence	Phase sequence reversal or open phase	Check the wiring.
Motor overload during start	Master start time set to less than the star delta delay time	Reset the master start time longer than star delay + 2 seconds.
Main Contactor shakes frequently	The emergency stop button is loose or controller is reset by interference	Check if the coil of contactor connects with RC snubber or not.
Inverter Communication Fault	Wrong set of relatively parameter of controller and Inverter; Communication cable loose	Check the set data Check the cable.

## Servicing

---

KRSV vacuum pumps require a minimum amount of inspection and maintenance. The controller and indicator alert the operator to perform required maintenance or repair unit problems.



### NOTICE

Use only authorized parts. Any damage or malfunction caused using unauthorized parts is not covered by Warranty or Product Liability.

### **6.1 FLUID CHANGE**

KRSV series vacuum pumps utilize a pressurized fluid drain. Use the following procedure to drain and replace the vacuum pump fluid.

- i. Run the vacuum pump for a while to warm the lubricant.
- ii. Stop the vacuum pump, power off.
- iii. Open drain valve on separator tank and fluid cooler, plug in drain hose.
- iv. Drain oil in a container or waste dedicated pipeline
- v. Close drain valve
- vi. Unscrew the plug in airtight discharge pipe and drain oil in a container or waste dedicated pipeline. Refit the plug.
- vii. Remove oil filter and pre-filter, drain oil, replace with a new part.
- viii. Remove the plug from the fluid fill port and refill the reservoir with the appropriate amount of KTL8000 fluid. Refit and tighten the plug.
- ix. Power on and start up vacuum pump for a few minutes, shut down.
- x. Unscrew the plug from the fluid fill port and refill the reservoir to the adequate level

### **6.2 AIR FILTER**

The standard Kaishan air filter is a single stage, dry type element. Air filter maintenance should be performed by the controller indication or every 4000 hours, or once a year, whichever comes first. Daily cleaning of the filter element is common in dirty conditions. Each time the filter is serviced, inspect the filtered air side of the air cleaner canister and the suction manifold for dirt. If dirt is found, determine the cause and correct. Always make sure all gaskets, threaded connections, flange connections, and hose connections between the air filter and vacuum pump are airtight. Dirty filters result in reduced airflow and can distort the element and allow dirt to bypass the filter element.



**NOTICE**

Intake filtration equipment supplied from the factory may not be adequate for extremely dirty applications or some forms of dust or vapors. It is the customer's responsibility to provide adequate filtration for those conditions. Warranty will be voided if inadequate filtration causes a failure.

### **6.3 FLUID FILTER**

The fluid filter is a spin on, full flow unit. Replacement of the filter requires spinning off the cartridge and replacing it with a new one. During normal service, the filter cartridge should be replaced under the following conditions, whichever occurs first:

- ◆ As indicated by the fluid filter maintenance indicator when the fluid is at normal operating temperature
- ◆ Every 2,000 hours
- ◆ Every fluid change

The oil pre-filter is a stainless-steel metal mesh filter. Clean oil pre-filter when replacing the fluid filter. The minimum cleaning interval shall be 2000 h. Replace it if any damage is found.



**NOTICE**

The fluid filter maintenance indicator may read high upon start up on cool mornings due to sluggish fluid creating higher than normal differential pressures. Monitor indicator after the fluid warms up.

### **6.4 AIR/OIL SEPARATOR**

The air/oil separator is using coalescent filter element. Replacement requires unbolting and lifting the separator cover and replacing it with a new one. The air/oil separator should be replaced as indicated in the maintenance schedule or as follows:

- ◆ If excessive fluid carryover is observed.
- ◆ 8,000 hours MAX, or-as indicated by differential pressure indicator.
- ◆ As indicated by the gauge (if equipped).

### **6.5 FLUID SAMPLING PROCEDURE**

KRSV models are required performing oil sample procedure every 2000 h. The following is a sampling procedure, with fixed sampling hardware installed.

- i. Take sample at normal operating conditions
- ii. Hold the oil drain hose into lubricant sample bottle.
- iii. Slowly open the sample valve.

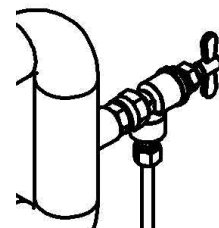

- iv. Collect oil, avoid overfilling the sample bottle.
- v. Close the sample valve.
- vi. Seal the bottle tightly, wipe clean.
- vii. Pre-label or label sample bottle immediately after filling to avoid mix-ups. Make sure bottles are labelled with full sample details.

## **6.6 MAINTENANCE SCHEDULE**

This Schedule is intended to be used as a guideline only. Depending on the specific operating conditions of your KRSV vacuum pump, maintenance requirements may vary. The instructions in this section will give more details about determining when specific service should be performed.

Time interval	Action
First 500 hours	Change fluid filter
Every 500 hours	Drain water from air/oil separator tank. Check fluid level Check air filter, clean if necessary Check for loose fluid and air tubing, electrical wiring connection.
Every 2000 hours	Check fluid level, top up if necessary Check control valves Check coolers, clean if necessary Replace fluid filter Clean filter element of electric enclosure Clean oil pre-filter Perform fluid sampling
Every 4000 hours	Clean cooler Replace air/oil separator Clean filter element of electric enclosure, change if necessary Check fluid level Replace air filter Clean oil pre-filter
Every 8000 hours	Check equipment power supply and earth-grounding. Replace air/oil separator Replace fluid Replace filter element of electric enclosure Clean oil pre-filter
Every 24000 hours	Motor overhaul Replace rubber hoses

## Troubleshooting Guide

Information below is a troubleshooting guideline; it describes symptoms and possible cause. Do not assume that these are the only faulty condition that may occur.

Symptom	Possible Cause	Solution
Fail to Start	Power failure	Check power supply to the unit
	Low incoming voltage	Check voltage and power source or contact local power company.
	Fuse blown	Replace Fuse
	Faulty start switch	Check the switch for malfunction or loose connection.
	Emergency button	Reset emergency button
	Motor starter overload tripped	Check motor starter wiring before removing motor. Remove motor and have tested at motor manufacturer repair center.
	Loose wire connections	Check all wiring terminals for contact and tightness
	Air-end failure	Contact a local authorized distributor.
Vacuum pump shuts down during loaded condition	High ambient temperature	Make fresh air intake openings or install ducts to discharge the hot air.
	Low incoming voltage	Check voltage and power source or contact local power company.
	High tank pressure due to separator clogged	Replace separator element
	Low fluid level	Top-up fluid
	PLC controller indicate separator requires maintenance	Replace separator element.
High discharge temperature	lubricant is insufficient.	Check add top up lubricant
	Incorrect grade of coolant	Check and replace lubricant
	High ambient temperature	Add ventilation measure to cool down room temperature
	Oil filter clogged	Replace oil filter
	Oil cooler clogged	Clean cooler
	Accumulated dusts on cooler surfaces	Clean cooler fins

<b>Symptom</b>	<b>Possible Cause</b>	<b>Solution</b>
High discharge temperature	Ventilation duct clogged	Check for cooling air restriction or increase the duct size. Clean duct.
	Failure of temperature sensor	Replace temperature sensor Check and repair
Unable to maintain vacuum	Plugged air filter	Clean air filter or replace with new element
	Air Intake valve malfunctioning	Remove the intake hose and check the inlet valve for proper operation
	Air leakage	Check for leakages in the air filter assembly and piping.
	Air demand exceeds vacuum pump flow capacity	Select a proper vacuum pump
	Solenoid valve malfunctioning	Repair or replace as necessary
	Variable speed drive malfunctioning	Repair or replace as necessary
Excessive oil carry over	High oil level	Check oil level
	Plugged oil orifice valve	Clean or replace as necessary
	Low discharge pressure	Adjust
	Air/oil separator element failure	Clean or replace as necessary
	Fluid foaming	Drain off oil and change
	Incorrect grade lubricant	Use KRSV genuine fluid
Short period of load/unload	Pipe leak	Check and replace as necessary
	Pressure setting	Change setting

## Standard Terms and Conditions

---

These terms and conditions govern the sale of Products (“Rotary Screw Vacuum pumps and parts”) and provisions of services by Kaishan Vacuum pump USA (Seller) and its authorized representative or buyer. These terms and conditions (“Agreement”) take precedence over Buyer’s supplemental or conflicting terms and conditions to which notice of objection is hereby given. Neither Seller’s commencement of performance or delivery shall be deemed or construed as acceptance of Buyer’s supplemental or conflicting terms and conditions. Kaishan Vacuum pump USA’s failure to object to conflicting or additional terms will not change or add to the terms of this agreement. Buyer’s acceptance of the Products and/or Services from Seller shall be deemed to constitute acceptance of the terms and conditions contained herein.

**Orders:** All orders placed by Buyer are subject to acceptance by Seller. Orders may not be canceled or rescheduled without Seller’s written consent. All orders must identify the products, unit quantities, part numbers, applicable prices and requested delivery dates of the Products being purchased. Seller may at its sole discretion allocate Product among its Buyer. Seller may designate certain Products and Services as non-cancelable, non-returnable and the sale of such Products shall be subject to the special terms and conditions contained in Seller’s Customer Acknowledgement or Non-Returnable Product Form, which shall prevail and supersede any inconsistent terms and conditions contained herein or elsewhere.

**Prices:** The prices of the Products are those prices specified on the front of the invoice or contained within an agreed written contract. Price quotations shall automatically expire in thirty (30) days from the date issued, or as otherwise stated in the quotation.

**Taxes:** Unless otherwise agreed to in writing by Seller, all prices quoted are exclusive of transportation and insurance costs, duties, and all taxes including federal, state and local sales, excise and value added, goods and services taxes, and any other taxes. Buyer agrees to indemnify and hold Seller harmless for any liability for tax in connection with the sale, as well as the collection or withholding thereof, including penalties and interest thereon. When applicable, transportation and taxes shall appear as separate items on Seller’s invoice.

**Payment:** Payment may be made by check, money order, credit card, or wire transfer (all fees are borne by the Buyer). Where Seller has extended credit to Buyer, terms of payment shall be net thirty (30) days from date of invoice, without offset or deduction. On any past due invoice, Seller may impose a monthly interest rate. If Buyer fails to make the required payments the Seller will impose the interest rate each month. If Buyer fails to make each payment when it is due, Seller reserves the right to withdraw credit and thereby suspend or cancel performance under any or all purchase orders or agreements in which Seller has extended credit to Buyer. In the event of default by Buyer, Seller shall be entitled to costs, fees, and expenses including but not limited to recovery of attorney fees, court costs and fees, and collections costs.

**Delivery and Title:** The locations of shipment delivery will be made according to the Seller and Buyer agreement. Title and risk of loss pass to the Buyer upon delivery of the Product to the carrier. Seller's delivery dates are estimates only and Seller is not liable for delays in delivery or for failure to perform due to causes beyond the reasonable control of the Seller, nor shall the carrier be deemed an agent of the Seller. A delayed delivery of any part of an Order does not entitle Buyer to cancel other deliveries. Kaishan Vacuum pump USA will comply with various federal, state and local laws and regulation concerning occupational health, safety and environment concerns. Buyer has full responsibility to comply with those laws and regulations during the installation and operation of the equipment.

**Acceptance / Returns:** Shipments will be deemed to have been accepted by Buyer upon delivery of the said shipments to Buyer unless rejected upon receipt. Buyer shall perform all inspections and tests. Buyer deems necessary as promptly as possible but in no event later than 7 days after receipt of Products, at which time Buyer will be deemed to have irrevocably accepted the Products. Any discrepancy in shipment quantity must be reported within 7 days after receipt of Products. Buyer may not return Products without a Return Material Authorization ("RMA") number. RMA's valid for 30 days from the date issued.

**Standard Warranty:** Buyer will honor Product warranties and indemnities authorized by the manufacturer, including any transferable. 90 days warranty is given for service parts from receipt date. Seller warrants to Buyer that Products purchased hereunder will conform to the applicable manufacturer's specifications for such products and that any value-added work performed by Seller on such Products will conform to applicable Buyer's specifications. If Seller breaches this warranty, Buyer's remedy is limited to (at Seller's election) (1) refund of Buyer's purchase price for such Product (without interest), (2) repair of such Products, or (3) replacement of such Products provided that such Products must be returned to Seller, along with acceptable evidence of purchase within 13 days from date of delivery, transportation charges prepaid. No warranty will apply if the Product has been subject to misuse, neglect, accident or modification.

**Limitation of Liabilities:** Buyer shall not be entitled to, and Seller shall not be liable for, loss of profit or revenue, promotional or manufacturing expenses, overheads expenses, business interruption cost, loss of data, removal or reinstallation costs, injury to reputation of buyer, punitive damages, loss of contractor orders or any indirect, special, incidental or consequential damages of any nature. Buyer's recovery from seller for any claim shall not exceed the purchase price paid for the affected products irrespective of the nature of the claim whether in contract, tort, warranty, or otherwise. Buyer will indemnify, defend and hold seller harmless from any claims based on (a) Seller's compliance with buyer's designs, specifications, or instructions, (b) Modification of any products by anyone other than Seller, or (c) use in combination with other products not supplied by seller.



**Use of Products:** Unless otherwise specified. Products sold by Seller are not designed, intended or authorized for use in life support, life sustaining, nuclear, or other applications in which the failure of such Products could reasonably be expected to result in personal injury, loss of life or catastrophic property damage. If buyer uses or sales the Products for use in any such applications: (1) Buyer acknowledges that such use or sale is at Buyer's sole risk; (2) Buyer agrees that Seller and the manufacturer of the Products are not liable, in whole or in part, for any claim or damage arising from such use; and (3) Buyer agrees to indemnify, defend and hold Seller and the manufacturer of the Products harmless from and against any and all claims, damages, losses, costs, expenses and liabilities arising out of or in connection with such use or sale.

**Force Majeure:** Seller is not liable for failure to fulfill its obligations for any accepted Order or for delays in delivery due to causes beyond Seller's reasonable control including, but not limited to, acts of God, natural or artificial disaster, riot, war, strike, delay by carrier, shortage of Product, acts or omissions of other parties, acts or omissions of civil or military authority, Government priorities, changes in law, material shortages, fire, strikes, floods, epidemics, quarantine restrictions, acts of terrorism, delays in transportation or inability to obtain labor, materials or products through its regular sources, which shall be considered as an event of force majeure excusing Seller from performance and barring remedies for non-performance. In an event of force majeure condition, the Seller's time for performance shall be extended for a period equal to the time lost as a consequence of the force majeure condition without subjecting Seller to any liability or penalty. Seller may, at its option, cancel the remaining performance, without any liability or penalty, by giving notice of such cancellation to the Buyer.

**General:** (a) Seller will comply with state law for any dispute from buyer. (b) Buyer may not assign this Agreement without the prior written consent of Seller. Seller or its affiliates may perform the obligations under this Agreement. This Agreement is binding on successor and assigns, (c) Products, including software or other intellectual property, are subject to any applicable rights of third parties, such as patents, copyrights and/or user licenses.

## Contact Information

---

Kaishan Compressor, LLC.,  
Add.: 15445 Industrial Park Dr., Loxley, AL, Post code: 36551  
Office number: +1 251-202-0577  
[www.KaishanUSA.com](http://www.KaishanUSA.com)