

All materials supplied are in compliance with the requirements of the List of Prohibited Substances

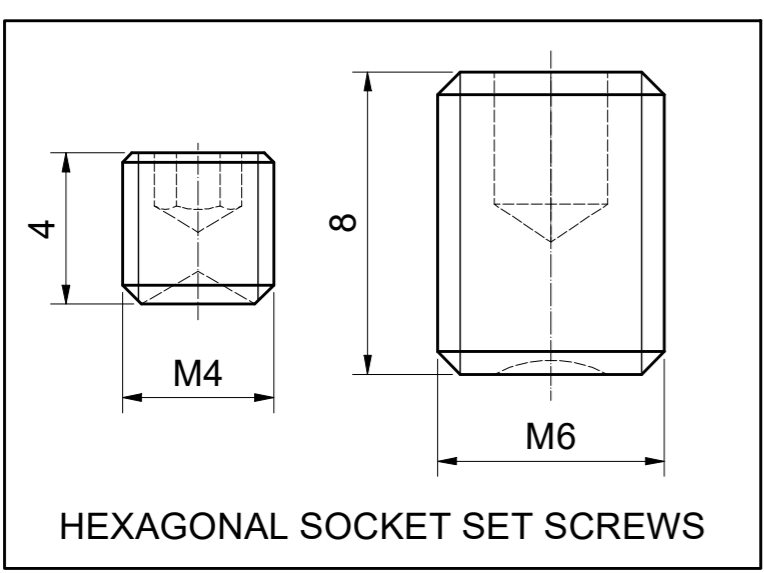
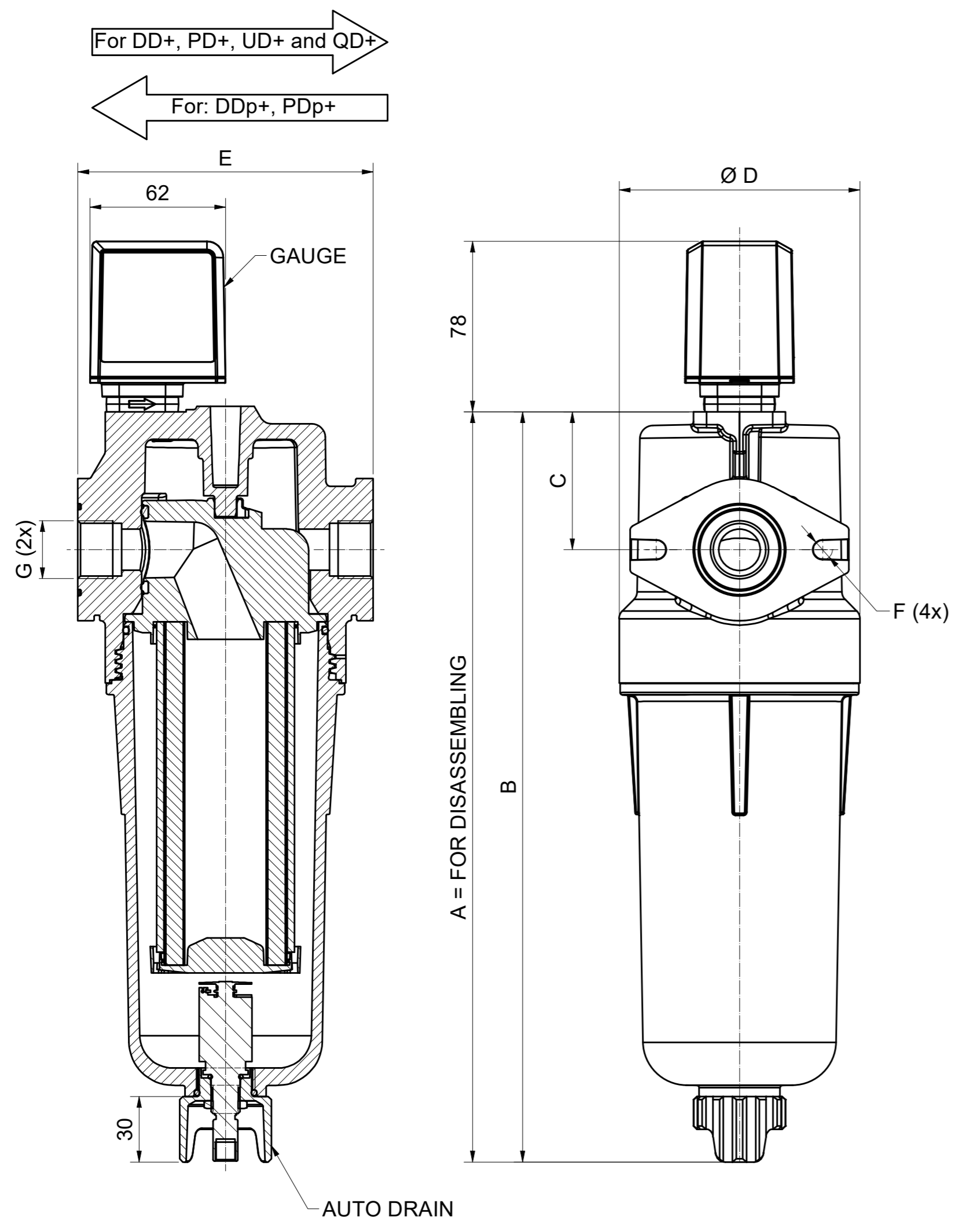

STANDARD SCOPE OF SUPPLY														
DESIGNATION	7	15	25	45	75	110	145	180	240	300	360	430	525	630
DD+	1+3	1+3	1+3	2+3	2+3	2+3	2+3	2+3	2+3	2+3	2+3	2+3	2+3	2+3
PD+	1+3	1+3	1+3	2+3	2+3	2+3	2+3	2+3	2+3	2+3	2+3	2+3	2+3	2+3
UD+	1+3	1+3	1+3	2+3	2+3	2+3	2+3	2+3	2+3	2+3	2+3	2+3	2+3	2+3
DDp+	1+4	1+4	1+4	2+4	2+4	2+4	2+4	2+4	2+4	2+4	2+4	2+4	2+4	2+4
PDp+	1+4	1+4	1+4	2+4	2+4	2+4	2+4	2+4	2+4	2+4	2+4	2+4	2+4	2+4
QD+	4+5	4+5	4+5	4+5	4+5	4+6	4+6	4+6	4+6	4+6	4+6	4+6	4+6	4+6

1. POP UP INDICATOR
2. GAUGE
3. AUTO DRAIN
4. MANUAL DRAIN
5. HEXAGONAL SOCKET SCREW M4x4
6. HEXAGONAL SOCKET SCREW M6x8

TYPE	NET MASS (Kg)	A	B	C	D	E	F	G	
7	1.2	353	263	52	90	106	7	G 1/2	NPT 1/2
15	1.25	353	263	52	90	106	7	G 1/2	NPT 1/2
25	1.43	406	315.5	52	90	106	7	G 1/2	NPT 1/2
45	2.43	453	343	63	110	135	9	G 3/4	NPT 3/4
75	2.87	538	428	63	110	135	9	G 1	NPT 1
110	5.08	590	459.5	84.5	143	175	8.5	G 1 1/2	NPT 1 1/2
145	5.6	660	529.5	84.5	143	175	8.5	G 1 1/2	NPT 1 1/2
180	6.12	730	599.5	84.5	143	175	8.5	G 1 1/2	NPT 1 1/2
240	9.34	805	630	98	171	222	11.5	G 2	NPT 2
300	10.38	898	723	98	171	222	11.5	G 2	NPT 2
	10.2							G 2 1/2	NPT 2 1/2
360	10.2	898	723	98	171	222	11.5	G 2 1/2	NPT 2 1/2
430	13.98	1028	827.5	110	191	250	11.5	G 3	NPT 3
525	15.32	1144	943.5	110	191	250	11.5	G 3	NPT 3
630	19.24	1382	1181.5	110	191	250	11.5	G 3	NPT 3

G or NPT Thread

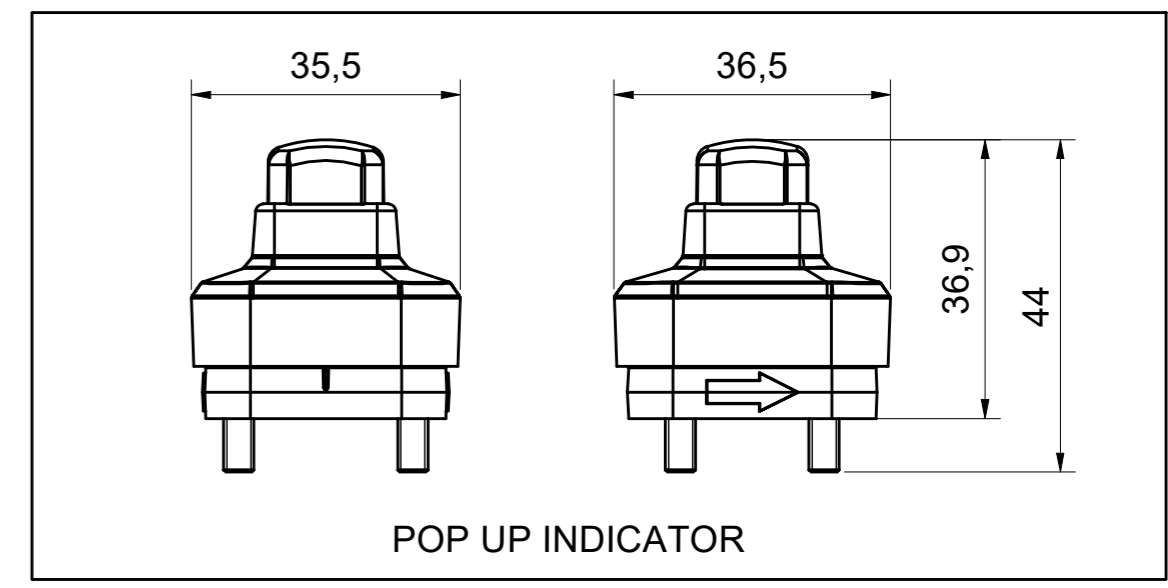
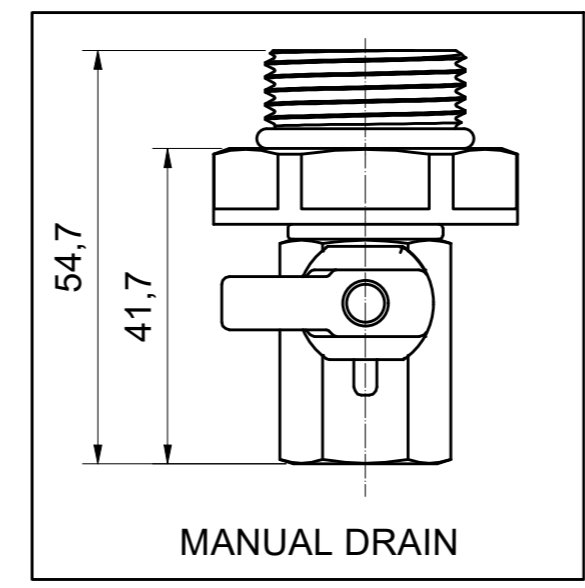

All Dimensions are in Metric System

Designation	Recommended Torque
Pressure Gauge + Indicator	3,5 Nm
Automatic Drain	3 Nm
Manual Drain	3 Nm

Tolerances, if not indicated, according to:  
ATLAS COPCO STANDARD CLASS

Name	DIMENS. DRWG		DIMENS. DRWG (NO BYPASS)		Confidentiality Class acc. to 1102 K
Material	See Drawing		See Drawing		Confidential
Treatment	See Drawing		See Drawing		INV
	Scale	1 : 2	Family	A2	Compare
	Drawn by	INENR	Blank nr.		Replaces
STATUS	Version Drwg	Blank wt	Kg	Fini wt.	NA
Released	Des checked.	Prod checked.	Approved.	Date	13/05/2020

Designation: 9827928800-01

Sheet 1 / 2

Drawing owner: API

**CONFIDENTIAL:** This document is our property and shall not without our permission be altered, copied, used for manufacturing or communicated to any other person or company.

Ed	Position	Modified from	Date	Intr./Appd.
1			28/05/2021	User Agent

All materials supplied are in compliance with the requirements of the List of Prohibited Substances

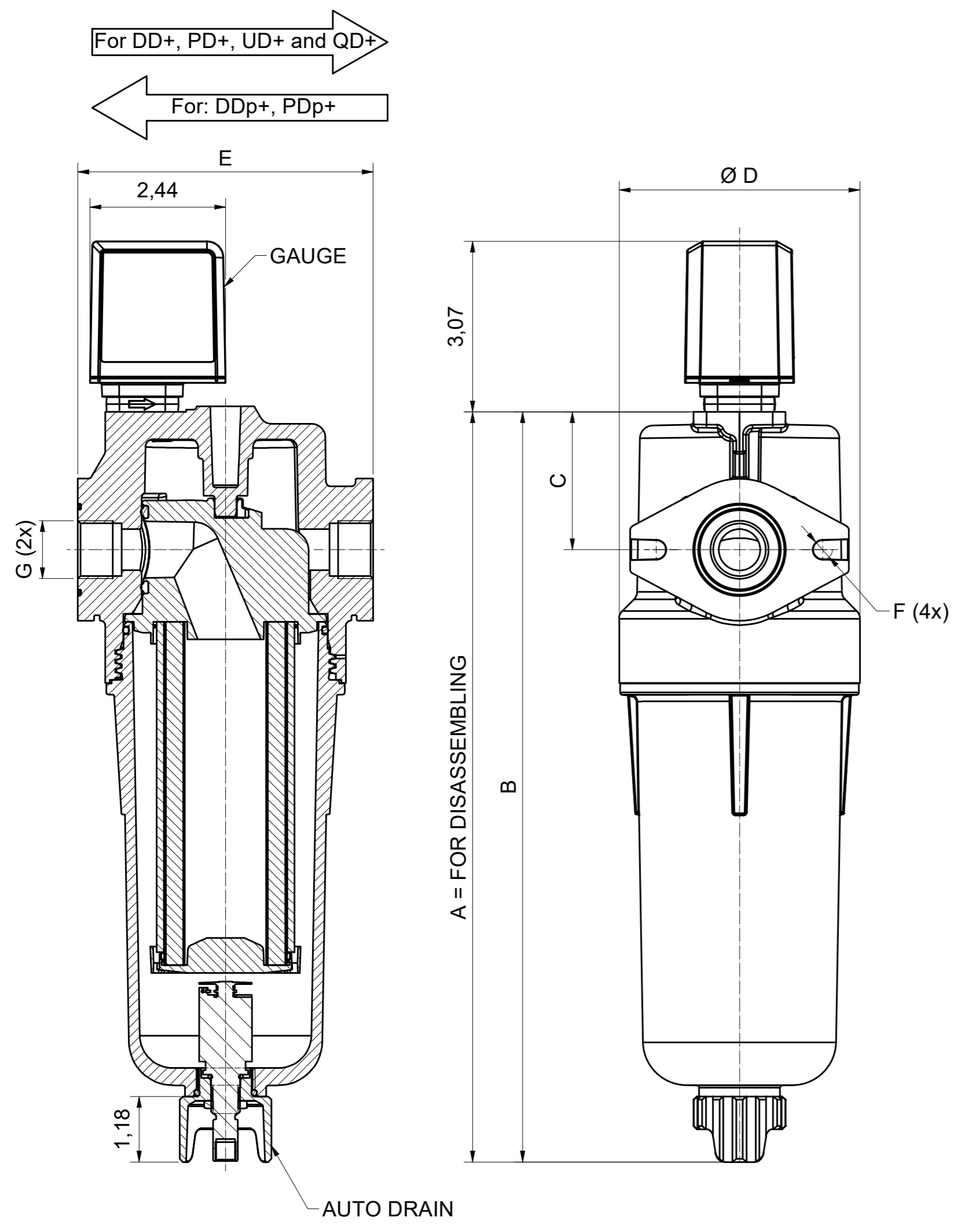

STANDARD SCOPE OF SUPPLY														
DESIGNATION	7	15	25	45	75	110	145	180	240	300	360	430	525	630
DD+	1+3	1+3	1+3	2+3	2+3	2+3	2+3	2+3	2+3	2+3	2+3	2+3	2+3	2+3
PD+	1+3	1+3	1+3	2+3	2+3	2+3	2+3	2+3	2+3	2+3	2+3	2+3	2+3	2+3
UD+	1+3	1+3	1+3	2+3	2+3	2+3	2+3	2+3	2+3	2+3	2+3	2+3	2+3	2+3
DDp+	1+4	1+4	1+4	2+4	2+4	2+4	2+4	2+4	2+4	2+4	2+4	2+4	2+4	2+4
PDp+	1+4	1+4	1+4	2+4	2+4	2+4	2+4	2+4	2+4	2+4	2+4	2+4	2+4	2+4
QD+	4+5	4+5	4+5	4+5	4+5	4+6	4+6	4+6	4+6	4+6	4+6	4+6	4+6	4+6

1. POP UP INDICATOR
2. GAUGE
3. AUTO DRAIN
4. MANUAL DRAIN
5. HEXAGONAL SOCKET SCREW M4x4
6. HEXAGONAL SOCKET SCREW M6x8

TYPE	NET MASS (Lbs)	A	B	C	D	E	F	G	
7	2.65	13.90	10.35	2.05	3.54	4.17	0.28	G 1/2	NPT 1/2
15	2.76	13.90	10.35	2.05	3.54	4.17	0.28	G 1/2	NPT 1/2
25	3.15	15.98	12.42	2.05	3.54	4.17	0.28	G 1/2	NPT 1/2
45	5.36	17.83	13.50	2.48	4.33	5.31	0.35	G 3/4	NPT 3/4
75	6.33	21.18	16.85	2.48	4.33	5.31	0.35	G 1	NPT 1
110	11.20	23.23	18.09	3.33	5.63	6.89	0.33	G 1 1/2	NPT 1 1/2
145	12.35	25.98	20.85	3.33	5.63	6.89	0.33	G 1 1/2	NPT 1 1/2
180	13.49	28.74	23.60	3.33	5.63	6.89	0.45	G 1 1/2	NPT 1 1/2
240	20.59	31.69	24.80	3.86	6.73	8.74	0.45	G 2	NPT 2
300	22.89	35.35	28.46	3.86	6.73	8.74	0.45	G 2	NPT 2
	22.49							G 2 1/2	NPT 2 1/2
360	22.49	35.35	28.46	3.86	6.73	8.74	0.45	G 2 1/2	NPT 2 1/2
430	30.83	40.47	32.58	4.33	7.52	9.84	0.45	G 3	NPT 3
525	33.78	45.04	37.15	4.33	7.52	9.84	0.45	G 3	NPT 3
630	42.42	54.41	46.52	4.33	7.52	9.84	0.45	G 3	NPT 3

G or NPT Thread

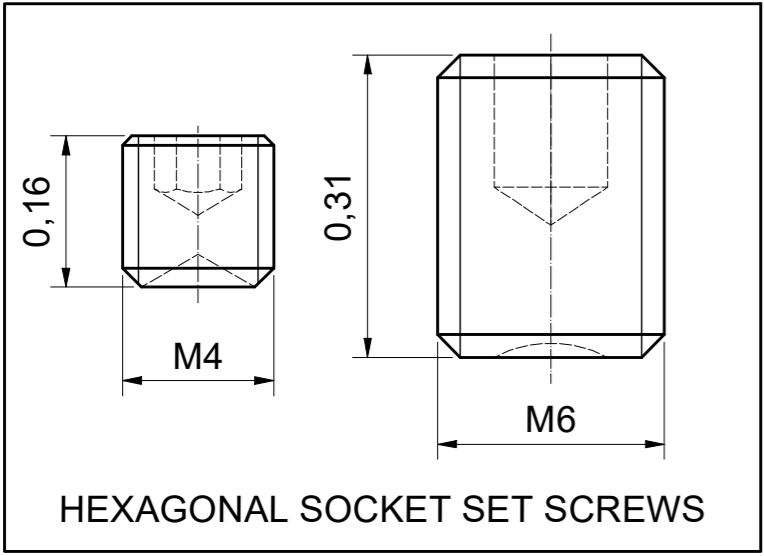
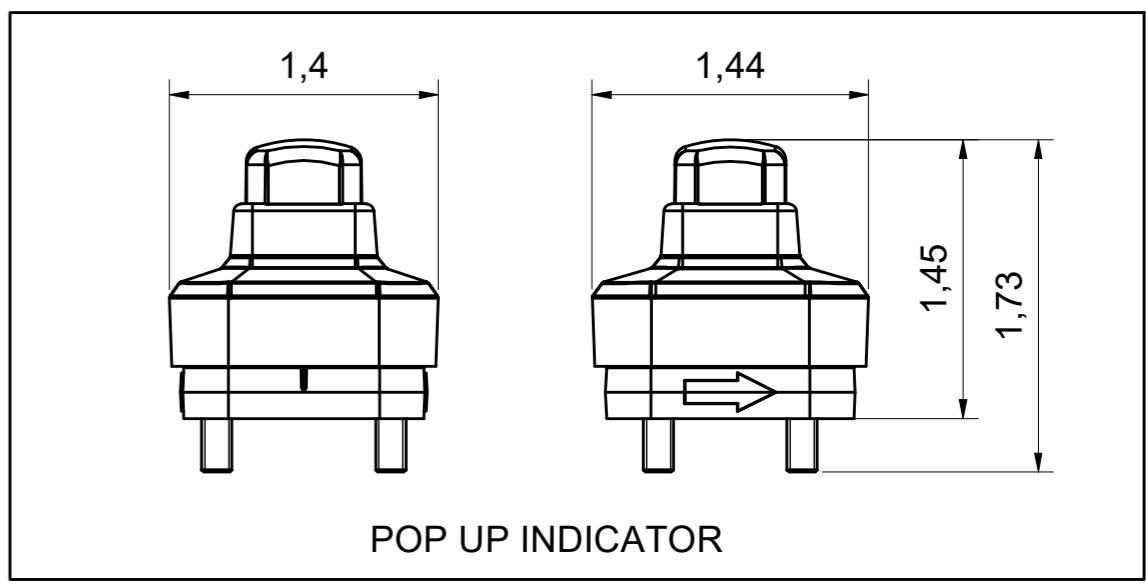
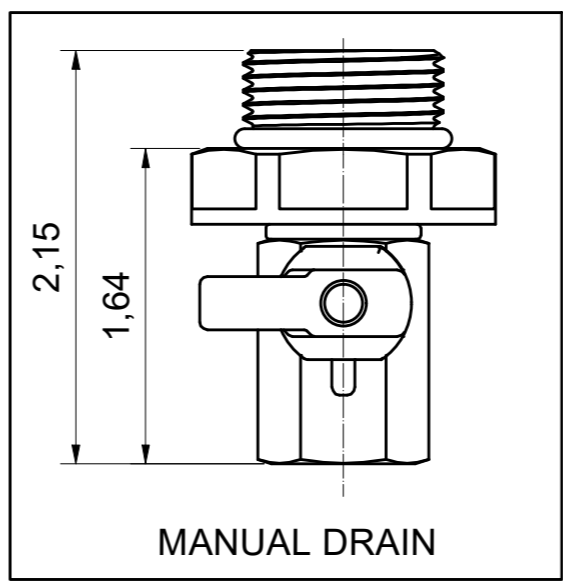

Designation	Recommended Torque
Pressure Gauge + Indicator	31 lb in
Automatic Drain	26.5 lb in
Manual Drain	26.5 lb in

Tolerances, if not indicated, according to:  
ATLAS COPCO STANDARD CLASS

Name	DIMENS. DRWG	DIMENS. DRWG (NO BYPASS)	Confidentiality Class acc. to 1102 K
Material	See Drawing		Confidential
Treatment	See Drawing		INV
Scale	1 : 2	Family	A2 Compare
Drawn by	INENR	Blank nr.	Replaces
Version Drwg		Blank wt	Kg
STATUS		Fini wt.	NA
Des checked.		Prod checked.	Approved.
Date	13/05/2020		

Released

Designation: 9827928800-01

Sheet 2 / 2

Ed	Position	Modified from	Date	Intr./Appd.
1			28/05/2021	User Agent

CONFIDENTIAL: This document is our property and shall not without our permission be altered, copied, used for manufacturing or communicated to any other person or company.