

FX850V

4 stroke air-cooled V-twin gasoline engine

OWNER'S MANUAL

Kawasaki

SAFETY AWARENESS

Whenever you see the symbols shown below, heed their instructions! Always follow safe operating and maintenance practices.

 DANGER
DANGER indicates a hazardous situation which, if not avoided, will result in death or serious injury.

 WARNING
WARNING indicates a hazardous situation which, if not avoided, could result in death or serious injury.

NOTICE
NOTICE is used to address practices not related to personal injury.

NOTE

○ *NOTE* indicates information that may help or guide you in the operation or service of the vehicle.

READ THIS FIRST

For your safety, read this Owner's Manual and understand it thoroughly before operating this ENGINE.

DANGER

Exhaust gas contains carbon monoxide, a colorless, odorless poisonous gas. Inhaling carbon monoxide can cause serious brain injury or death.

DO NOT run the engine in enclosed areas. Operate only in a well-ventilated area. Gasoline is extremely flammable and can be explosive under certain conditions, creating the potential for serious burns. When refueling, servicing fuel system, draining gasoline and/or adjusting the carburetor:

Stop engine and allow it to cool before refueling.

DO NOT smoke.

Make sure the area is well-ventilated and free from any source of flame or sparks, including the pilot light of any appliance.

DO NOT fill the tank so the fuel level rises into the filler neck or level surface of level gauge. If the tank is overfilled, heat may cause the fuel to expand and overflow through the vents in the tank cap.

Wipe off any spilled gasoline immediately.

Engines can become extremely hot during normal operation.

To prevent fire hazard:

Keep the engine at least 1 m (3.3 ft) away from buildings, obstructions and other burnable objects.

DO NOT place flammable objects close to the engine.

DO NOT expose combustible materials to the engine exhaust.

DO NOT use the engine on any forest covered, brush covered or grass covered unimproved land unless spark arrester is installed on the muffler.

To avoid getting an electric shock, **DO NOT** touch spark plugs, plug caps or spark plug leads during engine running. To avoid a serious burn, **DO NOT** touch a hot engine or muffler. The engine becomes hot during operation. Before you service or remove parts, stop engine and allow the engine to cool.

DO NOT place hands or feet near moving or rotating parts. Place a protective cover over pulley, V belt or coupling.

DO NOT run engine at excessive speeds. This may result in injury.

Always remove the spark plug caps from spark plugs when servicing the engine to prevent accidental starting.

Read warning labels which are on the engine and understand them. If any label is missing, damaged, or worn get a replacement from your Kawasaki engine dealer and install it in the correct position.

EMISSION CONTROL INFORMATION

Fuel Information

THIS ENGINE IS CERTIFIED TO OPERATE ON UNLEADED REGULAR GRADE GASOLINE ONLY. A minimum of 87 octane of the antiknock index is recommended. The antiknock index is posted on service station pumps in the U.S.A.

Emission Control Information

To protect the environment in which we all live, Kawasaki has incorporated an exhaust emission control system in compliance with applicable regulations of the United States Environmental Protection Agency. Also, depending on when your engine was produced, it may have an assigned emissions durability period.

* See below for the engine emissions durability period that may apply to your engine.

Exhaust Emission Control System

The exhaust emission control system applied to this engine consists of a carburetor and an ignition system having optimum ignition timing characteristics. The carburetor has been calibrated to provide specific air/fuel mixture characteristics and optimum fuel economy with a suitable air cleaner and exhaust system.

A sealed-type crankcase emission control system is also used to eliminate blow-by gasses. The blow-by gasses are led to a breather chamber through the crankcase and from there to the air cleaner.

Engine Emission Compliance Period

Engines Greater Than or Equal To 225 cc

Model Year-2015 and later

Durability Period-1000 hours (Category A)

*** If your engine has an assigned emissions durability period it will be located on the certification label attached to the engine (IMPORTANT ENGINE INFORMATION).**

High Altitude Performance Adjustment Information

To improve the EMISSIONS CONTROL PERFORMANCE of engines operated above 1000 meters (3300 feet), Kawasaki requires the following Environmental Protection Agency (EPA) approved modifications. High altitude adjustment requires replacement of carburetor main jets. Installation of these optional parts may be performed by an authorized Kawasaki engine dealer or equally qualified service facility, or the consumer, following repair recommendations specified in the appropriate Kawasaki Service document or parts catalog.

Operating with the wrong configuration at a given altitude may increase its emissions and decrease fuel efficiency and performance.

NOTE

- *When properly performed, these specified modifications only are not considered to be emissions system “tampering” and engine performance is generally unchanged as a result.*
- *Engine models with fuel injection do not require high altitude performance adjustment.*

Maintenance and Warranty

Proper maintenance is necessary to ensure that your engine will continue to have low emission levels. This Owner’s Manual contains those maintenance recommendations for your engine. Those items identified by the Periodic Maintenance Chart are necessary to ensure compliance with the applicable standards.

As the owner of the engine, you have the responsibility to make sure that the recommended maintenance is carried out according to the instructions in this Owner’s Manual at your own expense.

The Kawasaki Limited Emission Control System Warranty requires that you return your engine to an authorized Kawasaki engine dealer for remedy under warranty. Please read the warranty carefully, and keep it valid by complying with the owner’s obligations it contains.

Tampering with Emission Control System Prohibited

Federal law prohibits the following acts or the causing there of: (1) the removal or rendering inoperative by any person other than for purposes of maintenance, repair, or replacement, of any device or element of design incorporated into any new engine for the purposes of emission control prior to its sale or delivery to the ultimate purchaser or while it is in use, or (2) the use of the engine after such device or element of design has been removed or rendered inoperative by any person.

Among those acts presumed to constitute tampering are the acts listed below:

Do not tamper with the original emission related parts:

- Carburetor or DFI system, and their internal parts
- Spark Plug
- Magneto or electronic ignition system
- Fuel filter element
- Air cleaner element
- Crankcase
- Cylinder head
- Breather chamber and internal parts
- Intake pipe and tube

FOREWORD

We wish to thank you for purchasing this Kawasaki engine.

Please read this Owner's Manual carefully before starting your new engine so that you will be thoroughly familiar with the proper operation of your engine's control, its features, capabilities and limitations.

Also read the manual of the equipment to which this engine is attached.

To ensure a long, trouble-free life for your engine, give it the proper care and maintenance described in this manual. Always keep this manual at your fingertip so that you can refer to it whenever you need information. This manual should be considered a permanent part of the engine and should remain with the engine when it is sold.

All rights reserved. No part of this publication may be reproduced without our prior written permission.

This publication includes the latest information available at the time of printing. However, there may be minor differences between the actual product and illustrations and text in this manual.

All products are subject to change without prior notice or obligation.

KAWASAKI HEAVY INDUSTRIES, LTD.
Motorcycle & Engine Company

TABLE OF CONTENTS

GENERAL INFORMATION	8	MAINTENANCE	24
Location of Safety Related Labels.....	8	Periodic Maintenance Chart.....	24
Location of Parts	9	Oil Level Check	26
Engine Serial Number	10	Oil Cooler Service	26
Tune-up Specifications.....	10	Oil Change	27
Engine Oil Capacity.....	11	Oil Filter Change	28
FUEL AND OIL RECOMMENDATIONS	12	Air Cleaner Service	29
Fuel	12	Air Cleaner	29
Engine Oil.....	13	Primary Element.....	29
PREPARATION	14	Secondary Element.....	29
Fuel	14	Cap (Dust Ejector Valve).....	29
Engine Oil.....	15	Fuel Filter and Fuel Pump Service.....	31
STARTING	16	Spark Plug Service.....	32
Start Engine.....	16	Cooling System Cleaning.....	33
OPERATING	19	STORAGE	34
Warming Up.....	19	Engine Storage Procedure	34
Engine Inclination	20	TROUBLESHOOTING GUIDE	36
STOPPING	21	ENVIRONMENTAL PROTECTION	37
Stopping the Engine	21	SPECIFICATIONS	38
Ordinary Stop	21	WIRING DIAGRAM	39
Emergency Stop.....	21	Wiring Diagram	
ADJUSTMENT	22	(With 12 V - 15 A Charging Coil)	39
Separate Choke Type.....	22		
Throttle Cable Installation, Adjustment.....	22		
Choke Cable Installation, Adjustment.....	22		
Engine Speed Adjustment	23		

GENERAL INFORMATION

Location of Safety Related Labels

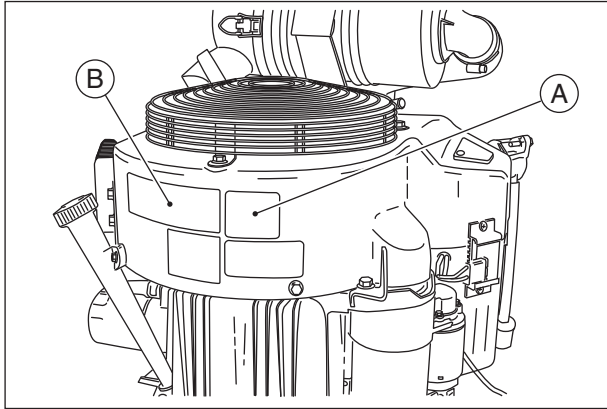

- A. Warning Label
- B. Engine Maintenance

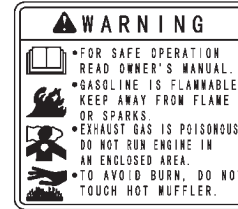

ENGINE MAINTENANCE

1. CHECK OIL LEVEL
2. CHECK & CLEAN AIR CLEANER
3. CLEAN FINS & SCREEN
4. CHANGE OIL & OIL FILTER

REFER TO OWNER'S MANUAL FOR FURTHER INFORMATION

CHECK OIL BEFORE STARTING

DO NOT TURN CAP ON THREADS WHEN CHECKING OIL LEVEL.

(TIGHTEN CAP WHEN FINISHED CHECKING)

Location of Parts

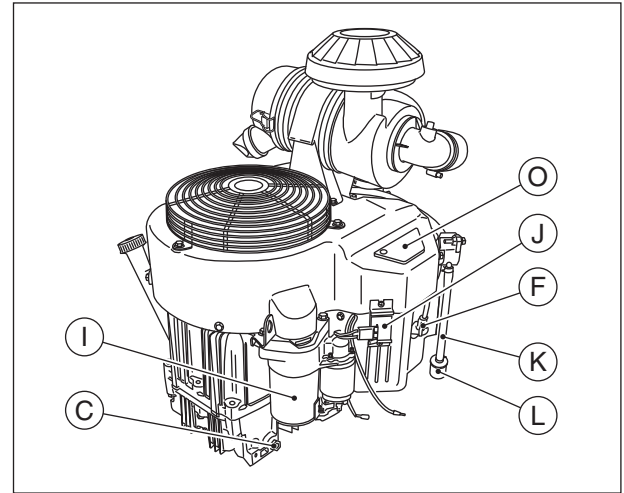
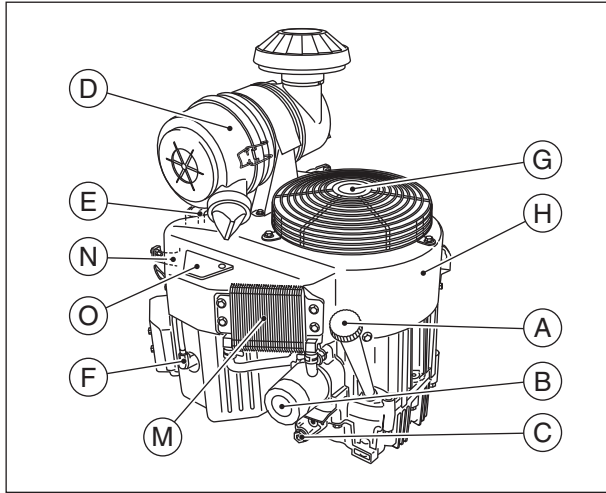

- | | |
|--|--|
| A. Oil Gauge Filler | I. Electric Starter |
| B. Oil Filter | J. Voltage Regulator |
| C. Oil Drain Plug | K. Fuel Tube |
| D. Air Cleaner | L. Fuel Filter |
| E. Carburetor | M. Oil Cooler |
| F. Spark Plug Cap/
Spark Plug | N. Control Panel |
| G. Guard | O. Cleanout Cover
(if equipped) |
| H. Fan Housing | |

10 GENERAL INFORMATION

Engine Serial Number

The engine serial number is your only means of identifying your particular engine from others of the same model type.

This engine serial number is needed by your dealer when ordering parts.

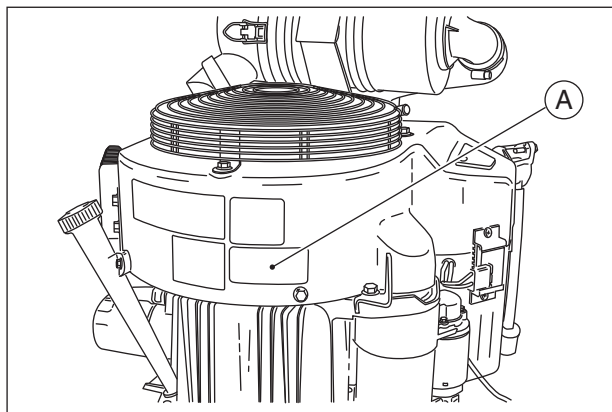

A. Engine Serial Number

Tune-up Specifications

ITEM	Specifications
Ignition Timing	Unadjustable
Spark Plugs: Gap	NGK BPR4ES 0.75 mm (0.030 in)
Low Idle Speed	1550 r/min (rpm)
High Idle Speed	3600 r/min (rpm)
Valve Clearance	IN 0.10 - 0.15 mm (0.004 - 0.006 in) EX 0.10 - 0.15 mm (0.004 - 0.006 in)
Other Specifications	No other adjustment needed

NOTE

- *High and low idle speeds may vary depending on the equipment on which the engine is used. Refer to the equipment specification.*

Engine Oil Capacity

Engine Oil Capacity

FX850V	2.1 L (2.2 US·qt) [when oil filter is not removed]
	2.3 L (2.4 US·qt) [when oil filter is removed]

FUEL AND OIL RECOMMENDATIONS

Fuel

Use only clean, fresh, unleaded regular grade gasoline.

NOTICE

Do not mix oil with gasoline.

Octane Rating

The octane rating of a gasoline is a measure of its resistance to “knocking”. **Using a minimum of 87 octane by the antiknock index is recommended.** The antiknock index is posted on service station pumps in the U.S.A.

NOTE

- If “knocking” or “pinging” occurs, use a different brand of gasoline or higher octane rating.
- When not operating your kawasaki engine more than once per month, you can mix a fuel stabilizer with gasoline in the fuel tank. Fuel stabilizer additive could inhibit oxidation of fuel.

Oxygenated Fuel

Oxygenates (either ethanol or MTBE) are added to the gasoline. If you use the oxygenates, be sure it is unleaded and meets the minimum octane rating requirement.

The followings are the EPA approved percentages of fuel oxygenates.

ETHANOL: (Ethyl or Grain Alcohol)

You may use gasoline containing up to 10% ethanol by volume.

MTBE: (Methyl Tertiary Butyl Ether)

You may use gasoline containing up to 15% MTBE by volume.

METHANOL: (Methyl or Wood Alcohol)

You may use gasoline containing up to 5% methanol by volume, as long as it also contains cosolvents and corrosion inhibitors to protect the fuel system. Gasoline containing more than 5% methanol by volume may cause starting and/or performance problems. It may also damage metal, rubber, and plastic parts of your fuel system.

Engine Oil

The following engine oils are recommended.
 API Service Classification: SF, SG, SH, SJ or SL.

Oil Viscosity

Choose the viscosity according to the temperature as follows:

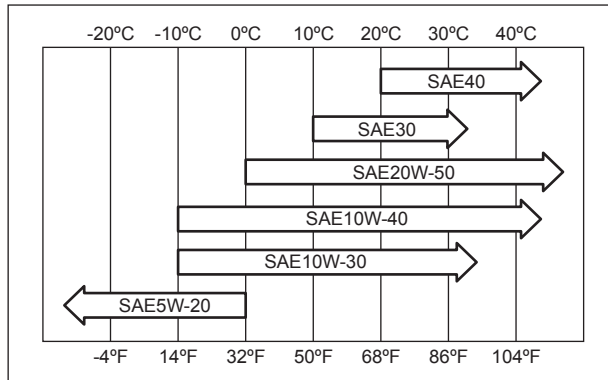

NOTE

- *Although 10W-40 engine oil is the recommended oil for most conditions, the oil viscosity may need to be changed to accommodate atmospheric conditions. Using 20W-50 oil in higher ambient temperatures may reduce oil consumption.*

PREPARATION

Fuel

 **WARNING**

Gasoline is extremely flammable and can be explosive under certain conditions, creating the potential for serious burns. Turn the ignition switch to “OFF”. Do not smoke.

Make sure the area is well-ventilated and free from any source of flame or sparks; this includes any appliance with a pilot light. Never fill the tank completely to the top. If the tank is filled completely to the top, heat may cause the fuel to expand and overflow through the vents in the tank cap. After refueling, make sure the tank cap is closed securely. If gasoline is spilled on the fuel tank, wipe it off immediately.

- Place the engine on level surface before fueling.
- Remove the fuel tank cap.
- Slowly pour fuel into the tank through the fuel strainer.
- Close the tank cap securely.

Engine Oil

Check the engine oil daily before starting the engine otherwise shortage of the engine oil may cause serious damage to the engine such as seizure.

- Place the engine on level surface. Clean area around the oil gauge before removing it.
- Remove the oil gauge and wipe it with a clean cloth.
- Pour the oil slowly to “FULL” mark on the oil gauge.
- Insert the oil gauge into tube WITHOUT SCREWING IT IN.
- Remove the oil gauge to check the oil level. The level should be between “ADD” and “FULL” marks. Do not over fill.
- Install and tighten the oil gauge.

Engine Oil Capacity

FX850V	2.1 L (2.2 US·qt) [when oil filter is not removed]
	2.3 L (2.4 US·qt) [when oil filter is removed]

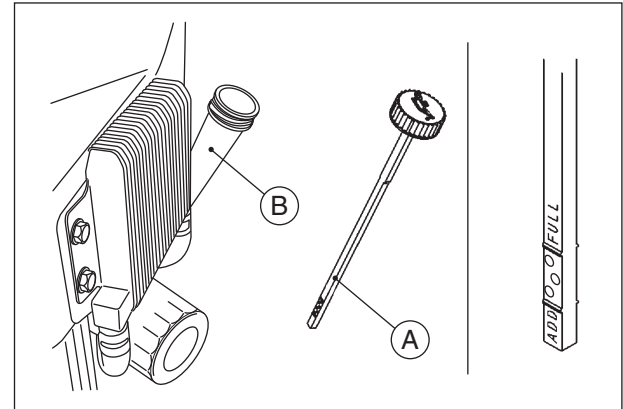

A. Oil Gauge
B. Tube

NOTICE

The engine is shipped without engine oil.

STARTING

Start Engine

DANGER

Exhaust gas contains carbon monoxide, a colorless, odorless poisonous gas. Inhaling carbon monoxide can cause serious brain injury or death. **DO NOT** run the engine in enclosed areas. Operate only in a well-ventilated area.

WARNING

Engine exhaust may ignite combustible materials and cause a fire. Keep the area around the exhaust outlet clear. Locate the unit so that the exhaust outlet points toward an open area and is located at least one meter (3.3 feet) from any obstructions.

NOTE

- *Be aware of the following in order to start the engine easily in cold weather.*

- *Use proper oil for expected temperature (See FUEL AND OIL RECOMMENDATIONS chapter). Use fresh gasoline.*
- *Protect the engine or the equipment from direct exposure to weather when not in operation.*
- *Before starting the engine, disconnect all possible external loads.*
- Open the fuel valve on the equipment.
- Put the engine switch key into the engine switch. For Control Panel Switch Type, move the throttle lever on the equipment to its halfway position between “SLOW” speed and “FAST” speed. Moving the lever away from its low speed end turns ignition on.

[Separate Choke type]

- **For a Cold Engine** - Place the choke control lever into “CHOKE” position.
- After starting the engine, gradually return the choke control lever to the fully open position.

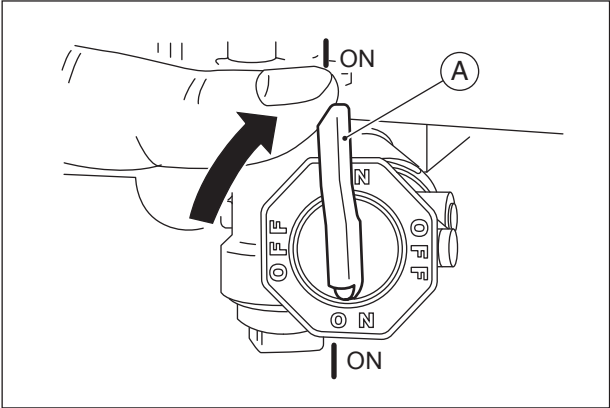

A. Fuel Valve

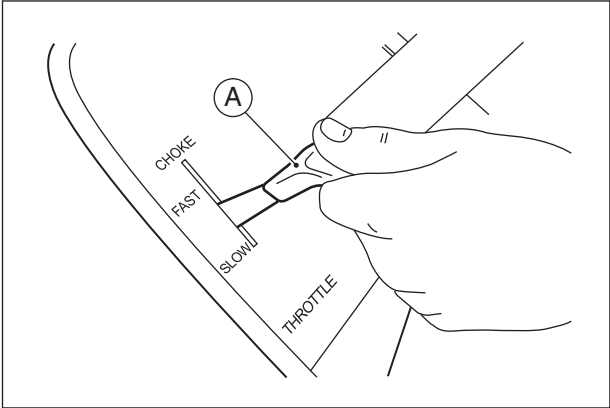

A. Throttle Lever

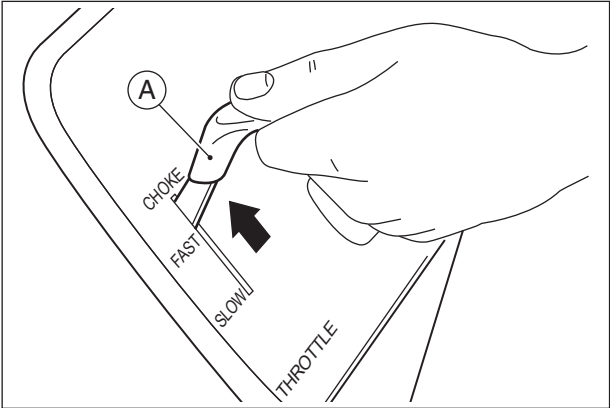

A. Throttle Lever

18 STARTING

- Put the switch key into the engine switch.
- Turn the switch key to the START position on the equipment. Normally the engine will start within 3 seconds.

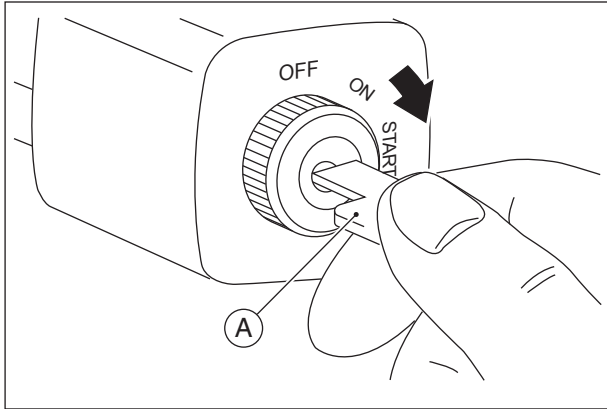

A. Switch Key

NOTICE

Do not run the electric starter continuously for more than 5 seconds, otherwise the battery may discharge quickly. If the engine does not start right away, wait 15 seconds and try again.

NOTICE

Whenever you start engine, make sure warning light is not illuminated after engine starts. If warning light comes on, stop engine immediately and check oil level (if equipped).

OPERATING

Warming Up

After the engine starts, move the throttle lever on the equipment to halfway between “FAST” and “SLOW”.

To warm up the engine, run it for 3 to 5 minutes with the throttle lever in the same load position (halfway) before putting the equipment under load. Then, move the throttle lever on the equipment to its “FAST” position.

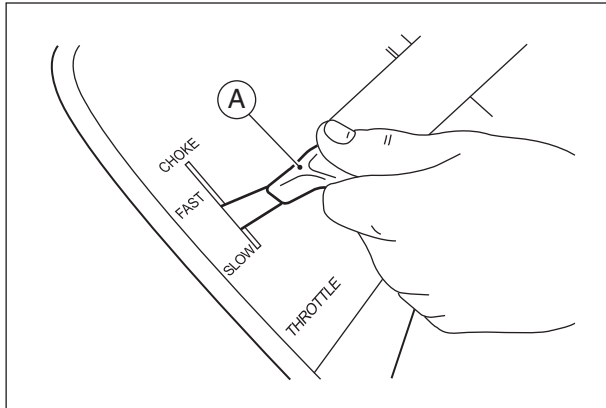

A. Throttle Lever

NOTICE

Allow engine to warm up sufficiently (3 to 5 minutes at idle) before applying a load. This will allow oil to reach all engine parts, and allow piston clearance to reach design specifications.

NOTICE

While warming up the engine, make sure the warning light (oil pressure) on dash is not on. The warning light must not be illuminated during engine operation (if equipped).

20 OPERATING

Engine Inclination

This engine will operate continuously at angles up to 25° in any direction.

Refer to the operating instructions of the equipment this engine powers. Because of equipment design or application, there may be more stringent restrictions regarding the angle of operation.

NOTICE

Do not operate this engine continuously at angles exceeding 25° in any direction. Engine damage could result from insufficient lubrication.

STOPPING

Stopping the Engine

Ordinary Stop

- Move throttle lever to “SLOW” position.
- Lower the engine speed to the idle speed. Keep running at the idle speed for about one minute.

NOTICE

Engine damage can occur from run-on or after-burning if engine is stopped suddenly from high speed loaded operation. Reduce engine speed to idle for one minute before shutting engine off.

- Turn the engine switch or the switch key to “OFF” position.

For Control Panel Switch Type, move the throttle lever against its low speed end to turn the ignition off.

Emergency Stop

- Immediately turn the engine switch or the switch key to “OFF” position.

- Close the fuel valve on the equipment.

For Control Panel Switch Type, move the throttle lever on the equipment to its low speed end. Moving the lever to its low speed end turns ignition off.

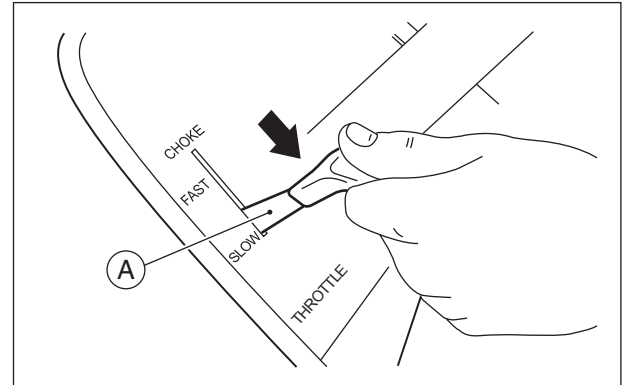

A. Throttle Lever

⚠ WARNING

Leaving the equipment with the key hanging in the ignition can allow operation by someone who does not know how to operate it. It may cause serious accident with injury. Always remove the key from unattended equipment.

ADJUSTMENT

Separate Choke Type

Throttle Cable Installation, Adjustment

- Link the throttle cable to the speed control lever and loosely clamp the throttle cable outer housing with the cable clamp bolt.
- Move the throttle lever to “FAST” position.
- Pull up the outer housing of the throttle cable until the inner wire has almost no slack, and tighten the cable clamp bolt.
- Move the throttle lever to “SLOW” position. Make sure that the carburetor throttle valve pivot arm is moved smoothly.

Choke Cable Installation, Adjustment

- Link the choke cable to the choke lever, and loosely clamp the choke cable outer housing with the cable clamp bolt.
- Move the equipment choke control to “OPEN” position. Make sure that the carburetor choke valve (pivot arm) is fully opened.
- Pull up the outer housing of the choke cable until the inner wire has almost no slack, and tighten the cable clamp bolt.

- Move the equipment choke control to “CHOKE” position. Make sure that the carburetor choke valve (pivot arm) is completely closed.
- Make sure that the choke valve turns from fully close position to fully open position when actuating the equipment choke control.

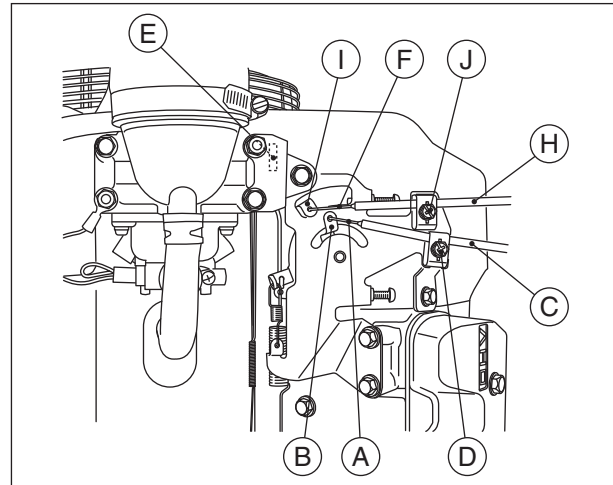

A. Throttle Cable

B. Speed Control Lever

C.H. Cable Outer Housing

D.J. Cable Clamp Bolt

E. Pivot Arm

F. Choke Cable

I. Choke Lever

Engine Speed Adjustment

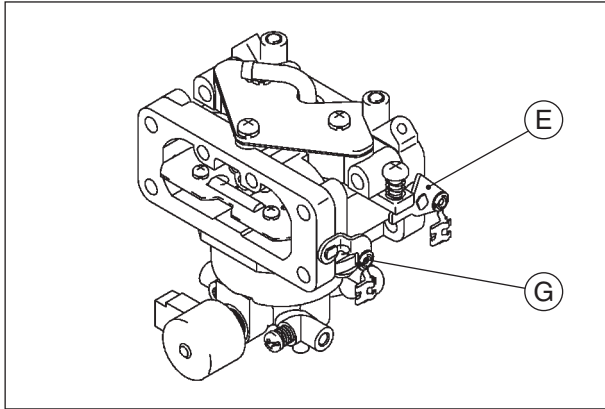

E. Throttle Valve Pivot Arm

G. Choke Valve Pivot Arm

NOTE

- *Do not tamper with the governor setting or the carburetor setting to increase the engine speed. Every carburetor is adjusted at the factory and cap or stop plate is installed on each mixture screw.*
- *If any adjustment is necessary, see your authorized Kawasaki engine dealer or equally qualified service facility to perform the adjustment.*

MAINTENANCE

Maintenance, replacement, or repair of the emission control devices and systems may be performed by any nonroad engine repair establishment or individual.

Periodic Maintenance Chart

 WARNING
--

Prevent accidental starting during engine service by removing the spark plug caps.

NOTE

○ *The service intervals can be used as a guide. Service more frequently as necessary by operating conditions.*

MAINTENANCE	INTERVAL						
	Daily	Every 50 hr.	Every 100 hr.	Every 200 hr.	Every 250 hr.	Every 300 hr.	Every 500 hr.
Check and add engine oil.	●						
Check for loose or lost nuts and screws.	●						
Check for fuel and oil leakage.	●						
Check battery electrolyte level.	●						
◆ Check or clean air inlet screen.	●						
Check cleanout cover.		●					
◆ Clean dust and dirt from cylinder and cylinder ◇ head fins.			●				
Tighten nuts and screws.			●				
Change engine oil.			●				
◆ Check and clean oil cooler fins.			●				
Clean and regap spark plugs.			●				
Change oil filter.				●			
◆ Replace air cleaner primary element.					●		
◆ Check air cleaner secondary element.					●		
◇ Clean combustion chamber.						●	
◇ Check and adjust valve clearance.						●	
◇ Clean and lap valve seating surface.						●	
◆ Replace air cleaner secondary element.							●

◆: Service more frequently under dusty conditions.

◇: Service to be performed by an authorized Kawasaki engine dealer or equally qualified service facility.

26 MAINTENANCE

Oil Level Check

Check the oil level daily and before each time of operation. Be sure the oil level is maintained. See PREPARATION chapter.

Engine Oil Capacity

FX850V	2.1 L (2.2 US·qt) [when oil filter is not removed]
	2.3 L (2.4 US·qt) [when oil filter is removed]

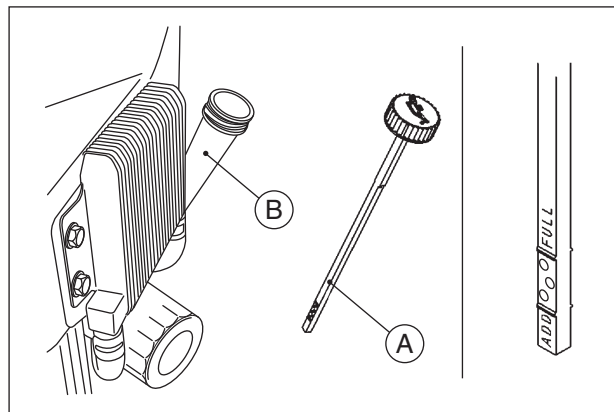

- A. Oil Gauge
- B. Tube

Oil Cooler Service

Check and clean oil cooler fins every 100 hours.

- Clean dirt off the outside fins with a brush or compressed air.

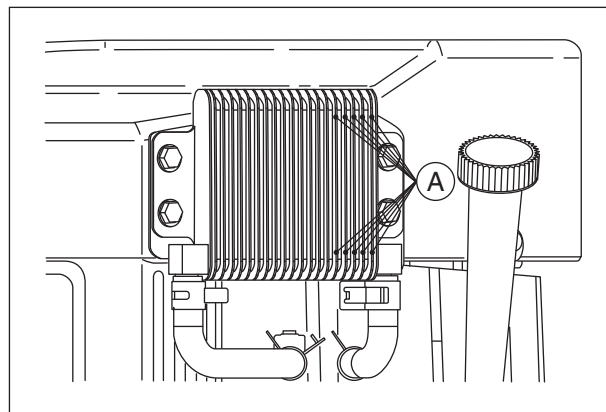

A. Oil Cooler Fins

Oil Change

Change oil every 100 hours.

- Run the engine to warm oil.
- Be sure the engine (equipment) is on level surface.
- Stop the engine.
- Remove the oil drain plug and drain the oil into a suitable container while engine is warm.

⚠ WARNING

Hot engine oil can cause severe burns. Allow engine temperature to drop from hot to warm level before draining and handling oil.

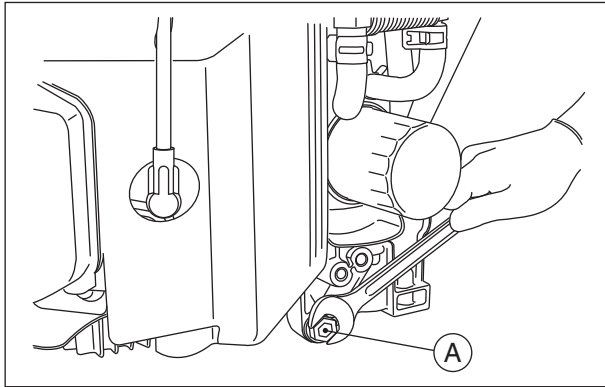

A. Oil Drain Plug

- Install the oil drain plug.
- Remove the oil gauge and refill with fresh oil (See FUEL AND OIL RECOMMENDATIONS chapter).
- Check the oil level (see PREPARATION chapter).

⚠ WARNING

Engine oil is a toxic substance. Dispose of used oil properly. Contact your local authorities for approved disposal methods or possible recycling.

28 MAINTENANCE

Oil Filter Change

- Change the oil filter every 200 hours of operation.

⚠ WARNING

Hot engine oil can cause severe burns. Allow engine temperature to drop from hot to warm level before attempting to remove oil filter.

- Drain the engine oil into a suitable container.

NOTICE

Before removing the oil filter, place suitable pan under filter connection.

- Rotate the oil filter counterclockwise to remove it.
- Coat a film of clean engine oil on the seal of new filter.
- Install new filter rotating it clockwise until the seal contacts the mounting surface. Then rotate the filter 2/3 turn more by hand.
- Supply engine oil as specified.
- Run the engine for about 3 minutes, stop the engine, and check any oil leakage around the filter.
- Add oil to compensate for oil level drop due to oil filter capacity (see PREPARATION chapter).

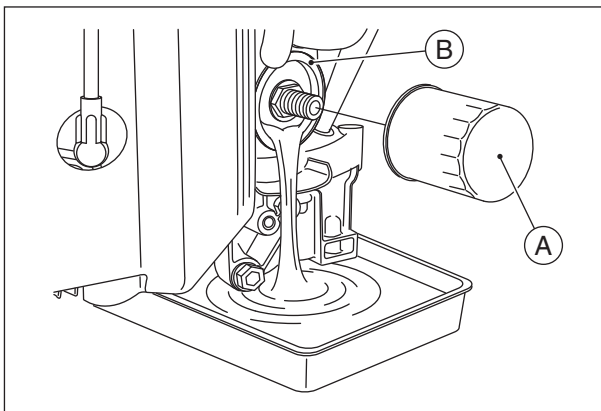

- A. Oil Filter
- B. Mounting Surface

⚠ WARNING

Engine oil is a toxic substance. Dispose of used oil properly. Contact your local authorities for approved disposal methods or possible recycling.

Air Cleaner Service

NOTICE

Do not run the engine with the air cleaner removed.

Air Cleaner

This air cleaner elements are not recommended to be cleaned. Replace each air cleaner element with a new one at the maintenance time as shown in the maintenance chart.

NOTICE

To prevent excessive engine wear, do not run the engine with the air cleaner removed.

NOTICE

**Do not wash air cleaner elements.
Do not oil air cleaner elements.
Do not use pressurized air to clean air cleaner elements.**

NOTE

- *Operating in dusty condition may require more frequent maintenance.*

Primary Element

Replace the primary element every 250 hrs.

Secondary Element

- Replace the secondary element with a new one, if the secondary element is dirty when the primary element is checked.
- Replace the secondary element with a new one every 500 hrs.

Cap (Dust Ejector Valve)

Push and open the cap on the case of the air cleaner body to expel dust and/or water accumulated inside.

- Unfasten the two retaining clamps and remove the case from the air cleaner body.
- Remove the primary element and the secondary element from the air cleaner body by pulling out them.

30 MAINTENANCE

- Install the new air cleaner elements into the air cleaner body.
- Reinstall the case and the cap then securely fasten the two retaining clamps.

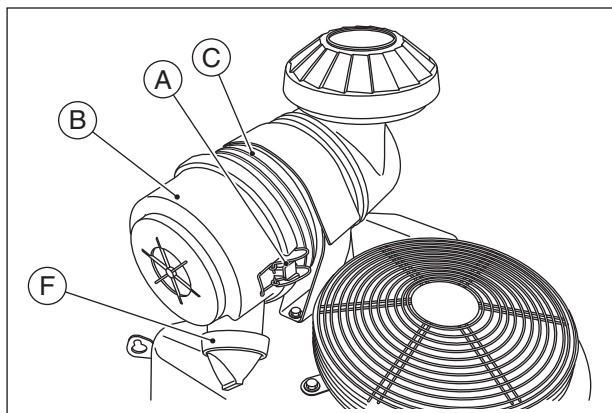

- A. Retaining Clamps
- B. Case
- C. Air Cleaner Body
- F. Cap (Dust Ejector Valve)

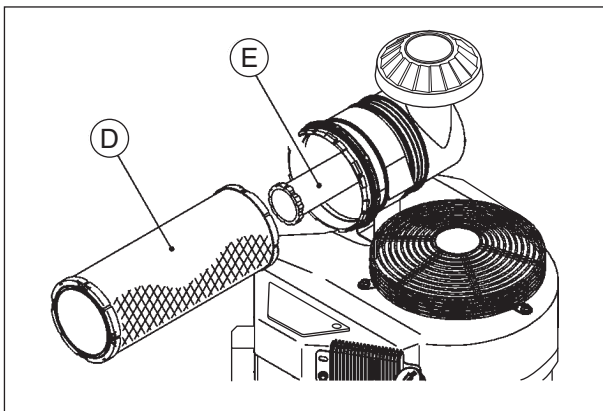

- D. Primary Element
- E. Secondary Element

Fuel Filter and Fuel Pump Service

⚠ WARNING

Improper use of solvents can result in fire or an explosion.

Do not use gasoline or low flash-point solvents to clean the fuel filter and/or the fuel pump.

Clean only in a well ventilated area away from sources of sparks or flame, including any appliances with a pilot light.

- The fuel filter can not be disassembled. If the fuel filter gets clogged, replace it with a new one.
- The fuel pump can not be disassembled. If the fuel pump fails, replace it with a new one.

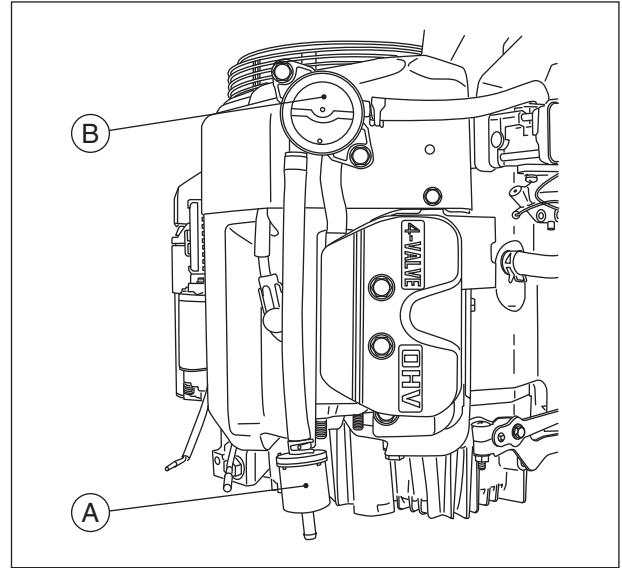

A. Fuel Filter
B. Fuel Pump

32 MAINTENANCE

Spark Plug Service

⚠ WARNING

Engines can become extremely hot during normal operation. Hot engine components can cause severe burns. Stop the engine and allow it to cool before checking spark plugs.

Clean or replace the spark plugs and reset the gap every 100 hours of operation.

- Disconnect the spark plug caps from the spark plugs and remove the spark plugs.
- Clean the electrodes by scraping or using a wire brush to remove carbon deposits.
- Inspect for cracked porcelain, other wear or damage. Replace the spark plug with a new one if necessary.
- Check the spark plug gap and reset it if necessary. The gap must be 0.75 mm (0.030 in). To change the gap, bend only the side electrode, using a spark plug tool.
- Install and tighten the spark plugs to 22 N·m (2.2 kgf·m, 16 ft·lb).
- Fit the spark plug caps on the spark plugs securely.
- Pull up the spark plug caps lightly to make sure of the installation of the spark plug caps.

RECOMMENDED SPARK PLUG

NGK.....BPR4ES

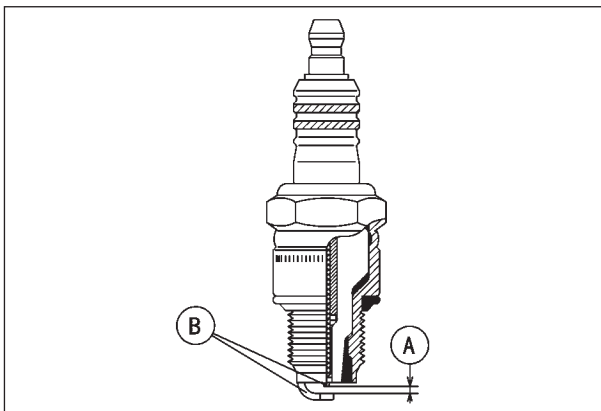

A. Spark Plug Gap
B. Electrodes

Cooling System Cleaning

Before each operation, check that the air inlet (rotary) screen is free from grass and debris. Clean the screen if necessary. Every 50 hours of operation, check the inside fan housing from the cleanout covers. To inspect the inside, loosen bolts of the cleanout covers and remove them. Every 100 hours of operation, check and clean the cooling fins and the inside of engine shrouds to remove grass, chaff or dirt clogging the cooling system and causing overheating. When cleaning, remove the guard and air inlet screen, then remove the fan housing and engine shrouds (includes removing the air cleaner, fuel pump, oil cooler and the voltage regulator parts) if necessary.

NOTICE

Do not run engine before all cooling system parts are reinstalled to keep cooling and carburetion as intended.

[Bolts Size, Tightening Torque]

Bolts	Size	Length	Tightening torque
B	M6	12 mm	5.9 N·m (0.6 kgf·m, 4.3 ft·lb)
D	M6	10 mm	5.9 N·m (0.6 kgf·m, 4.3 ft·lb)
F	M6	81 mm	5.9 N·m (0.6 kgf·m, 4.3 ft·lb)
I	M6	12 mm	8.8 N·m (0.9 kgf·m, 6.5 ft·lb)

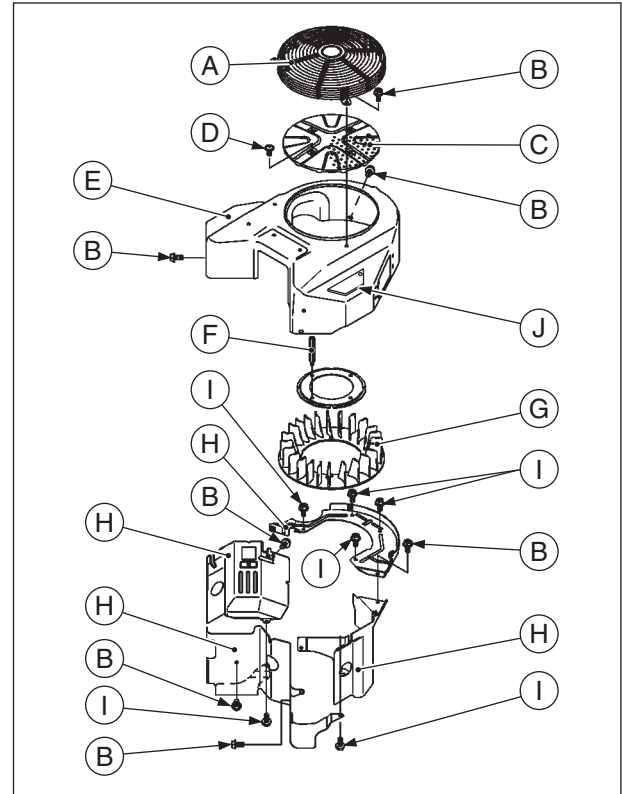

A. Guard
 B.D.F.I. Bolt
 C. Air Inlet Screen
 E. Fan Housing

G. Cooling Fan
 H. Shroud
 J. Cleanout Cover

STORAGE

Engine Storage Procedure

When not operating your Kawasaki engine more than 30 days, add fuel stabilizer to fuel tank and run engine for 5 minutes then drain the fuel tank.

After drain the fuel tank, run the engine at low idle until engine stalled.

⚠ WARNING

Gasoline is extremely flammable and can be explosive under certain conditions. Drain fuel before storing the equipment for extended periods. Drain gasoline in a well ventilated area away from any source of flame or sparks, including any appliances with a pilot light. Store gasoline in an approved container in safe location.

- Clean every part of the engine.
- Be sure that the engine switch or switch key is positioned at "OFF" position.
- Close the fuel valve and remove the sediment bowl.
- Put a pan under the fuel valve to receive the drained gasoline and open the fuel valve to drain

the gasoline from fuel tank completely.

- Install the sediment bowl.
- Put a pan under the carburetor and loosen the drain screw of the carburetor to drain the gasoline completely.
- Tighten the drain screw.

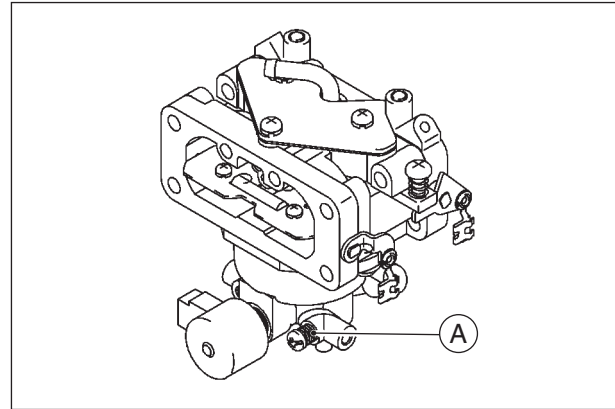

A. Fuel Drain Screw

⚠ WARNING

Gasoline is a toxic substance. Dispose of gasoline properly. Contact your local authorities for approved disposal methods.

- Remove the spark plugs and pour approx 1-2 mL (0.06-0.1 cu in.) of engine oil through the spark plug holes then screw the spark plugs in after turning the engine a few times. Slowly turn the engine until you feel the compression then leave it there. This traps the air inside the cylinders and prevents rust inside the engine.
- Wipe the body with oily cloth.
- Wrap the engine with plastic sheeting and store it in a dry place.
- Change engine oil for next use after period of storage. (Refer to MAINTENANCE chapter for Oil Change section).

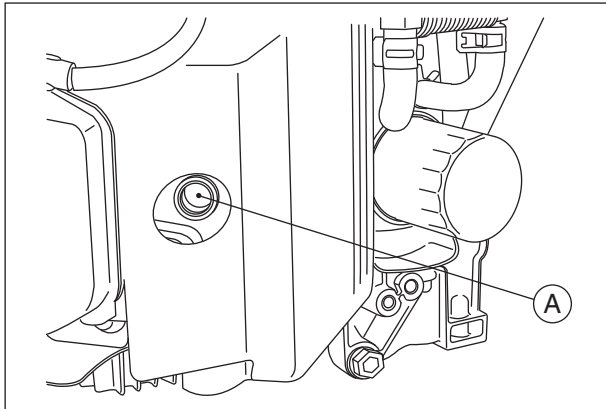

A. Spark Plug Hole

TROUBLESHOOTING GUIDE

If the engine malfunctions, carefully examine the symptoms and the operating conditions, and use the table below as a guide to trouble shooting.

Symptom		Probable Cause	Remedy
Engine won't start or output is low	Insufficient compression	Faulty pistons, cylinders, piston rings, and head gaskets	◇
		Faulty valves	
		Looses park plugs	Tighten properly
		Loose cylinder head bolts	
	No fuel to combustion chamber	No fuel in fuel tank	Fill fuel tank
		Fuel valve is not in "ON" position.	Open fuel valve lever.
		Clogged fuel filter or tube	Change fuel filter or fuel tube
		Clogged air vent in tank cap	Clean fuel tank cap
		Faulty carburetor	◇
	Spark plugs fouled by fuel	Over-rich fuel/air mixture	Open choke. Rotate engine with spark plugs removed to discharge excess fuel. Cleans park plugs.
		Clogged air cleaner	Clean
		Faulty carburetor	◇
		Incorrect grade/type of fuel	Change fuel
		Water in fuel	
No spark or weak spark	Faulty spark plugs	Replace spark plugs	
	Faulty ignition coils	◇	
	Engine switch is in "OFF" position	Turn engine switch to "START" position (See M)	
Low output	Engine overheats	Clogged air cleaner	Clean
		Air inlet screen or cooling air path clogged with dirt	
		Insufficient engine oil	Replenish or change oil
		Carbon build-up in combustion chamber	◇
		Poor ventilation around engine	Select a better location
	Engine speed won't increase	Faulty governor	◇

◇ : Service to be performed by an authorized Kawasaki engine dealer or equally qualified service facility.

M : For Control Panel Switch Type, move the throttle lever on the equipment away from it slow speed end to turn the engine switch to "START" position.

ENVIRONMENTAL PROTECTION

To help preserve the environment, properly discard used batteries, oils and fluids, or other engine components that you might dispose of in the future.

Consult your authorized Kawasaki engine dealer or equally qualified service facility or local environmental waste agency for their proper disposal procedure. This also applies to disposal of the entire engine at the end of its life.

SPECIFICATIONS

	FX850V
Type	Air-cooled, 4-stroke OHV 4Valves, V-twin cylinder, gasoline engine
Bore × Stroke	84.5 × 76 mm (3.33 × 2.99 in.)
Displacement	852 mL (52 cu.in.)
Ignition System	Solid-state ignition
Direction of rotation	Counterclockwise facing the PTO Shaft
Starting system	Electric starter
Dry weight : kg (lbs)	56.4 kg (124 lbs)

NOTE

- *Specifications are subject to change with out notice.*
- *Dry weight excludes that of the fuel tank and the muffler.*

WIRING DIAGRAM

Wiring Diagram (With 12 V - 15 A Charging Coil)

⚠ WARNING

For electrical safety, always remove cable from negative (-) side of battery before attempting any repair or maintenance.

Battery Capacity Recommended

Minimum Recommended Battery Capacity
12 V 550 CCA Class

NOTE

○ Portion surrounded by hatching shows Kawasaki procurement parts.

- | | |
|-------------------|----------------------|
| A. Flywheel | F. Key Switch |
| B. Ignition Coils | G. Fuse |
| C. Charging Coil | H. Voltage Regulator |
| D. Spark Plugs | I. Electric Starter |
| E. Battery | J. Carburetor |

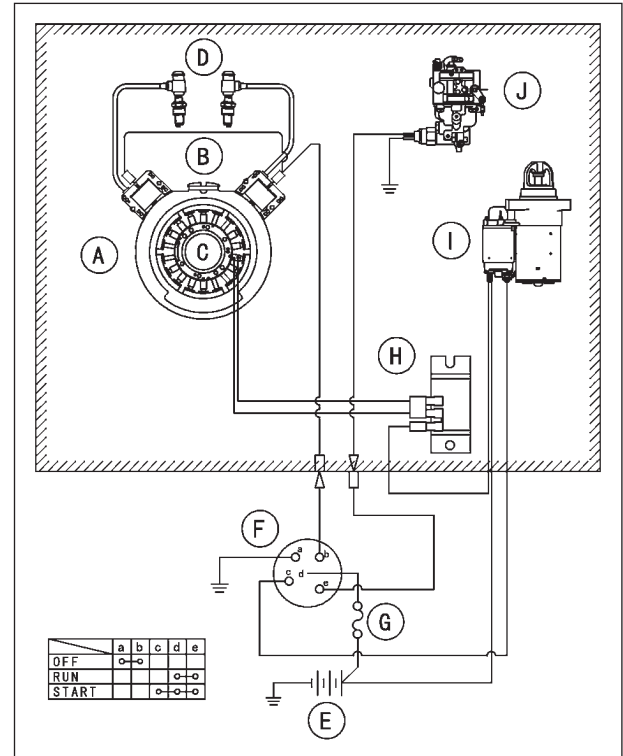

Part No. 99920-2232-06

**For repair / warranty assistance please contact
your local Kawasaki Authorized Dealer,
email: kawpower-website@kmc-usa.com or
call toll-free 1-877-364-6404**

Kawasaki Heavy Industries, Ltd. Motorcycle & Engine Company

Printed in Japan

GB