

WIRING INSTRUCTIONS

TITLE

SAWZALL®

BULLETIN
58-01-0065

MILWAUKEE ELECTRIC TOOL CORP. 13135 WEST LISBON RD. BROOKFIELD, WIS.

DATE
Feb. 2005

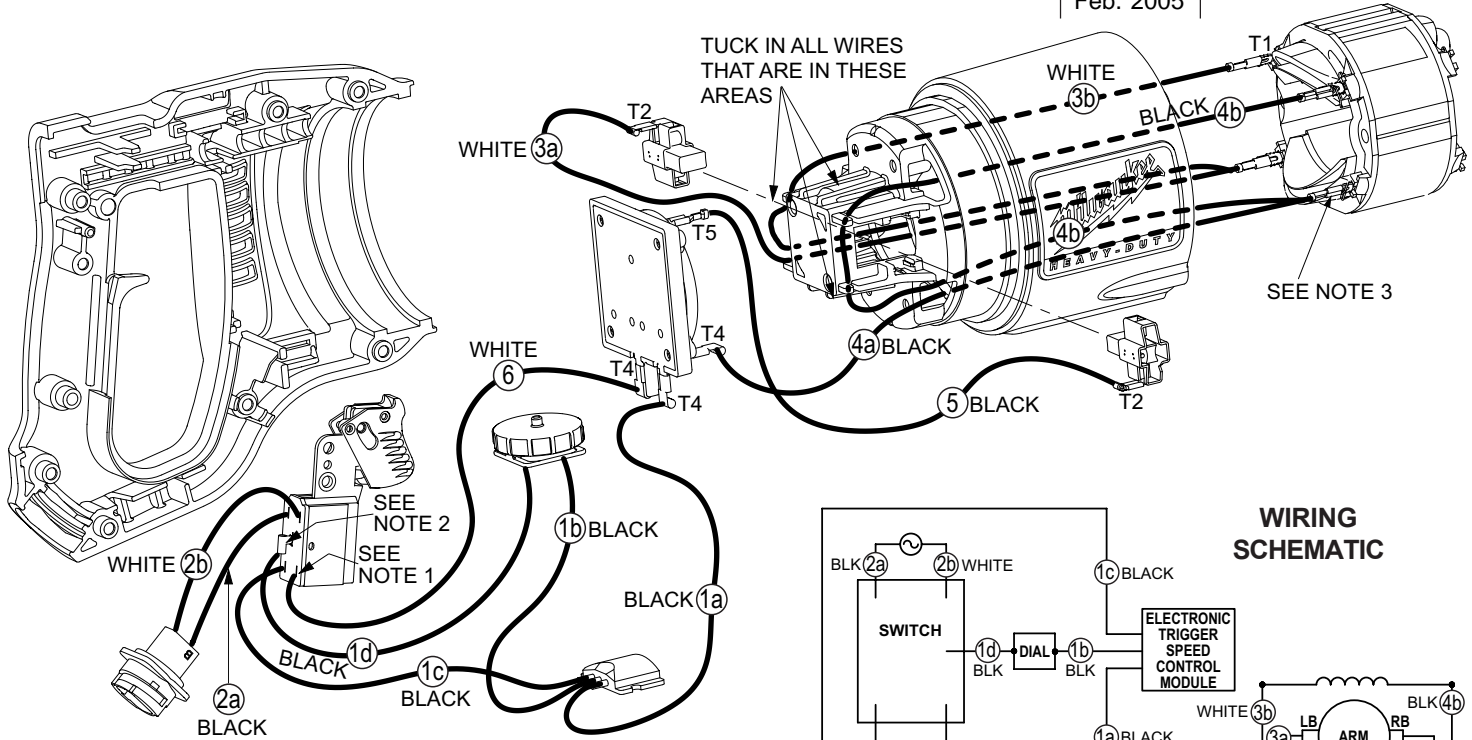

WIRING SCHEMATIC

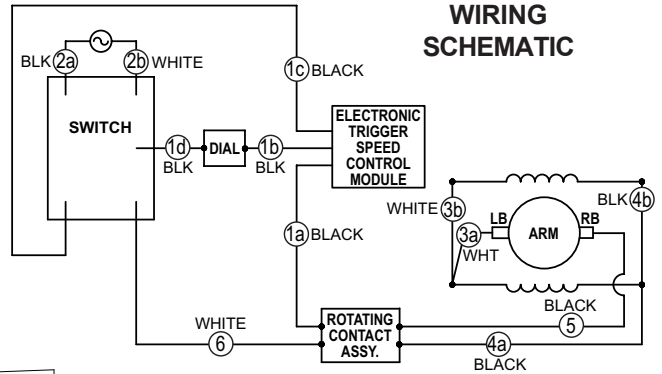

PLACE DIAL WIRES IN TRAPS PRIOR TO INSTALLING ROTATION LOCK BUTTON, (NOT SHOWN).

PLACE WIRES IN TRAPS.

PLACE WIRES BETWEEN SWITCH AND HANDLE BOSS AS SHOWN.

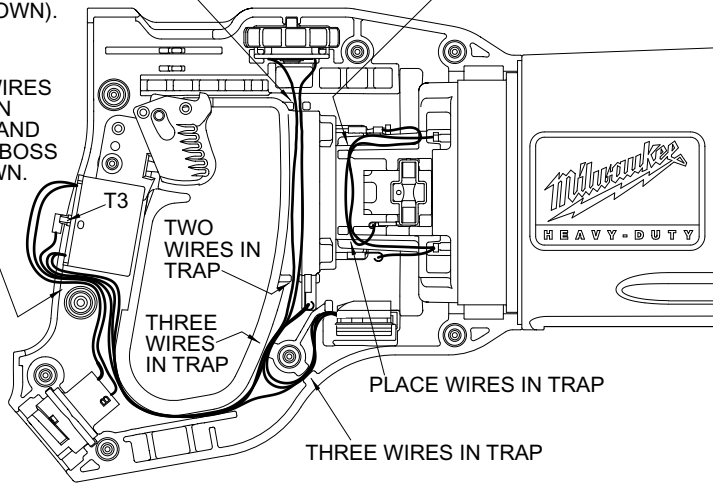

NOTES:

1. END OF WIRE INSULATION MUST BE BELOW OPENING IN DUST SHIELD ON SWITCH. (4 PLACES).
2. BENDING OF TERMINAL (T2) IS ACCEPTABLE. IF BENT DURING ASSEMBLY, DO NOT STRAIGHTEN.
3. TERMINALS MAY BE SECURED WITH BARRELS FACING IN OR OUT. (4 PLACES).

WIRING SPECIFICATIONS

Wire No.	Wire Color	Origin or Part No.	Ga.	Length	Terminals, Connectors and End Wire Preparation
1a	Black	14-20-1090	18	3.7	Component of remote dial assy. / Strip .19 for T4.
1b	Black	14-20-1090	18	7.25	Component of remote dial assy.
1c	Black	14-20-1090	18	7.0	Component of remote dial assy. / Strip .32 and tin.
1d	Black	14-20-1090	18	10.3	Component of remote dial assy. / Strip .19 for T3.
2a	Black	22-56-0700	16	---	Component of the blade housing assembly.
2b	White	22-56-0700	16	---	Component of the blade housing assembly.
3a	White	23-94-7400	18	3.13	Strip one end .19 for T2.
3b	White	23-94-7400	18	4.4	Strip one end .15 for T1. Strip both .15 and join for T1.
4a	Black	23-94-7405	18	2.05	Strip one end .19 for T4.
4b	Black	23-94-7405	18	4.4	Strip one end .15 for T1. Strip both .15 and join for T1.
5	Black	23-94-7410	18	3.0	Strip each end .19 for T2 and T5.
6	White	23-94-7415	18	7.25	Strip one end .32 and tin. / Strip other end .19 for T4.

NOTE:

All leads must be held to ± 1/8". All lead lengths are before stripping.

TERMINAL DESCRIPTION

Code	Part No.	Qty.
T1	23-74-1060	4
T2	23-74-0750	2
T3	23-74-0900	1
T4	23-74-0605	3
T5	23-74-0017	1

BULK LEAD WIRE - BULLETIN 58-01-0003