

WIRING INSTRUCTIONS

TITLE	5359-21 409A (Series I) 1-1/8" ROTARY HAMMER	DATE	BULLETIN
	MILWAUKEE ELECTRIC TOOL CORP. 13135 WEST LISBON RD. BROOKFIELD, WIS.	Jan. 2007	58-01-1860

**AS AN AID TO REASSEMBLY,
TAKE NOTE OF WIRE ROUTING
AND POSITION IN WIRE GUIDES
AND TRAPS WHILE
DISMANTLING TOOL.**

23-66-1687
SWITCH
(Back view)

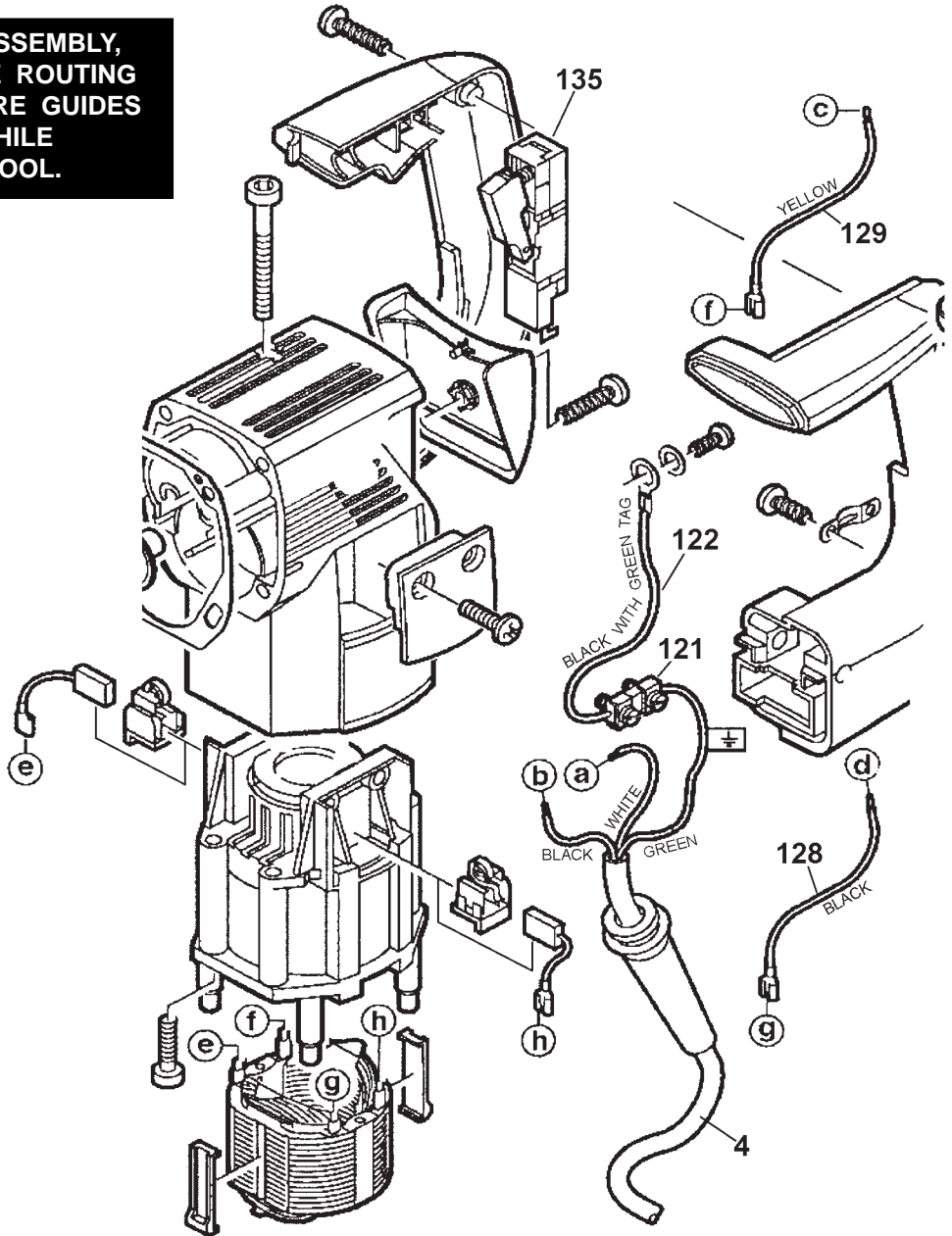
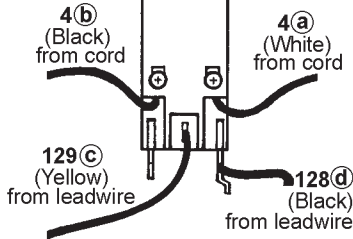

WIRING SPECIFICATIONS				
Wire No.	Wire Color	Origin or Gauge	Length	Terminals, Connectors and 1 or 2 End Wire Preparation
4a	White	Cord	----	Component of cord set
4b	Black	Cord	----	Component of cord set
4c	Green	Cord	----	Component of cord set
122	Black	23-94-1034	----	Leadwire assembly with green tag.
128	Black	23-94-1042	----	Leadwire assembly
129	Yellow	23-94-1037	----	Leadwire assembly

NOTE:
All leads must be held to $\pm 1/16"$.
All lead lengths are before stripping.

TERMINAL DESCRIPTION		
Code	Part No.	Qty.
CONNECTOR DESCRIPTION		

BULK LEAD WIRE - BULLETIN 58-01-0003