

TRANSFER SWITCHES

Pre-Wired Switch

PRE-WIRED AUTOMATIC TRANSFER SWITCH WITH
BUILT-IN LOAD CENTER

50 Amp, 250 VAC, NEMA 1

Model RTG12EZA1H



*Built in the USA using domestic and foreign parts.



FEATURES

- **The Honeywell Pre-Wired Switch** is designed to operate with the 11kW air-cooled generator. This transfer switch has an integrated load center for picking up the emergency circuits. It is especially useful where the main service is large and only a portion of the building load will be served by the generator. It is available with a built-in 12-circuit load center to supply only those circuits that are essential during an emergency. The pre-wired switch is CUL Listed and suitable for use in optional standby systems (NEC702).
- **The Honeywell Pre-Wired Switch** is housed in a steel NEMA 1 enclosure, with electrostatically applied and baked powder paint. The Heavy Duty Generac® Contactor is a UL recognized device, designed for years of service. The controller at the generator handles all the timing, sensing and exercising functions.
- **CONTACTOR RATING** The transfer switch contactor is rated at 250 VAC and is available in a single phase configuration only.

FUNCTIONS

All timing and sensing functions originate in the generator controller .

• Utility voltage drop-out	<60%
• Timer to generator start	10 second factory set, adjustable between 2-1500 seconds by a qualified dealer*
• Engine warm up delay	5 seconds
• Standby voltage sensor	60% for 5 seconds
• Utility voltage pickup	>80%
• Re-transfer time delay	15 seconds
• Engine cool-down timer	60 seconds
• Exerciser	12 minutes every 7 days

The transfer switch can be operated manually without power applied.

*When used in conjunction with units utilizing Sync 2.0™ controls

SPECIFICATIONS

Voltage	120/240, 1Ø
Amps	50
Circuits: 40A, 240V	1
30A, 240V	1
20A, 120V	3
15A, 120V	5
Phase	1
Rated AC Frequency	60 Hz
Enclosure Material	Steel
Enclosure Type	NEMA 1
Withstand Rating (Amps)	10,000
Lug Range	1/0 - #14
Load Transition Type	Open Transition
30' Whip Conductor Gauges (Hot, Neutral, Ground, Control)	8, 8, 10, 18
Tandem Breaker Capabilities	None

TRANSFER SWITCH FEATURES

- Electrically operated, mechanically-held contacts for fast, positive connections.
- Rated for all classes of load, 100% equipment rated, both inductive and resistive.
- 2 pole, 250 VAC contactor.
- 30 millisecond transfer time.
- Single coil design.
- Main contacts are silver plated or silver alloy to resist welding and sticking.
- NEMA 1 (indoor rated) enclosure is standard.
- 5 year comprehensive warranty

DIMENSIONS

Height			Width			Depth
H1	H2	H3	W1	W2	W3	
18.5 in.	22.5 in.	22 in.	10.5 in.	15.4 in.	14.4 in.	3.8 in.
470mm	571.8mm	558.8mm	266.7	392mm	366mm	97.5mm

Note: The 50 Amp switch is flush mountable. H1 and W1 refer to mounting hole spacing. H2 and W2 are cover dimensions. H3 and W3 (not shown in diagram) are the enclosure dimensions without cover.

WIRE RANGES

Conductor Lug	Neutral Lug	Ground Lug
1/0 - #14	2/0 - #14	2/0 - #14

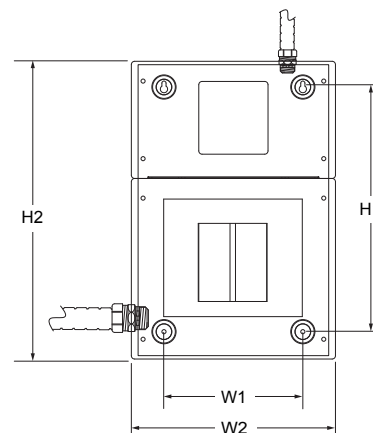

Generac Power Systems, Inc.

S45 W29290 Hwy. 59

Waukesha, WI 53187

Tel: 1-855-GEN-INFO

honeywellgenerators.com

0199210HWL-E

February 2016

© Generac Power Systems, Inc. All rights reserved. Specifications subject to change without notice.

The Honeywell Trademark is used under license from Honeywell International Inc.

Honeywell International Inc. makes no representation or warranties with respect to this product.

Honeywell