



EAGLE

Portable Tire Blaster and Air Tank



Owner's Manual

MODEL #: EA05-TB
EA10-TB

THIS INSTRUCTION MANUAL CONTAINS IMPORTANT SAFETY INFORMATION.
READ CAREFULLY AND UNDERSTAND ALL INFORMATION BEFORE OPERATING THIS TOOL.
SAVE THIS MANUAL FOR FUTURE REFERENCE.

⚠ WARNING

MAXIMUM PRESSURE 150 PSI. RECOMMENDED OPERATING PRESSURE 85-150 PSI.
 OVERFILLING MAY RESULT IN DEATH OR SERIOUS INJURY FILL THIS TANK ONLY FROM A SERVICE STATION OR SIMILAR LOW PRESSURE, -150-PSI AIR COMPRESSOR *REPLACE FILLER VALVES, AIR HOSE, GAUGE WITH LIKE FITTING. DEFLATE TANK BEFORE REMOVING FITTING. DISCHARGE TANK WHEN NOT IN USE. EAR PROTECTION RECOMMENDED. *WEAR SAFETY GLASSES* THIS PRODUCT CONTAINS CHEMICALS KNOWN TO THE STATE OF CALIFORNIA TO CAUSE CANCER AND BIRTH DEFECTS OR OTHER REPRODUCTIVE HARM. WASH HANDS THOROUGHLY AFTER HANDLING.

DO NOT REMOVE OR DEFACE THIS LABEL

WARNING:

- Do not store or transport a charged tank.
- Do not discharge the device towards anyone.
- Do not clean a tire with a flammable solvent before using this device.
- Do not subject the tank to any stress or impact that might weaken it.

TIRE BLASTER / AIR TANK COMPONENT DRAWING

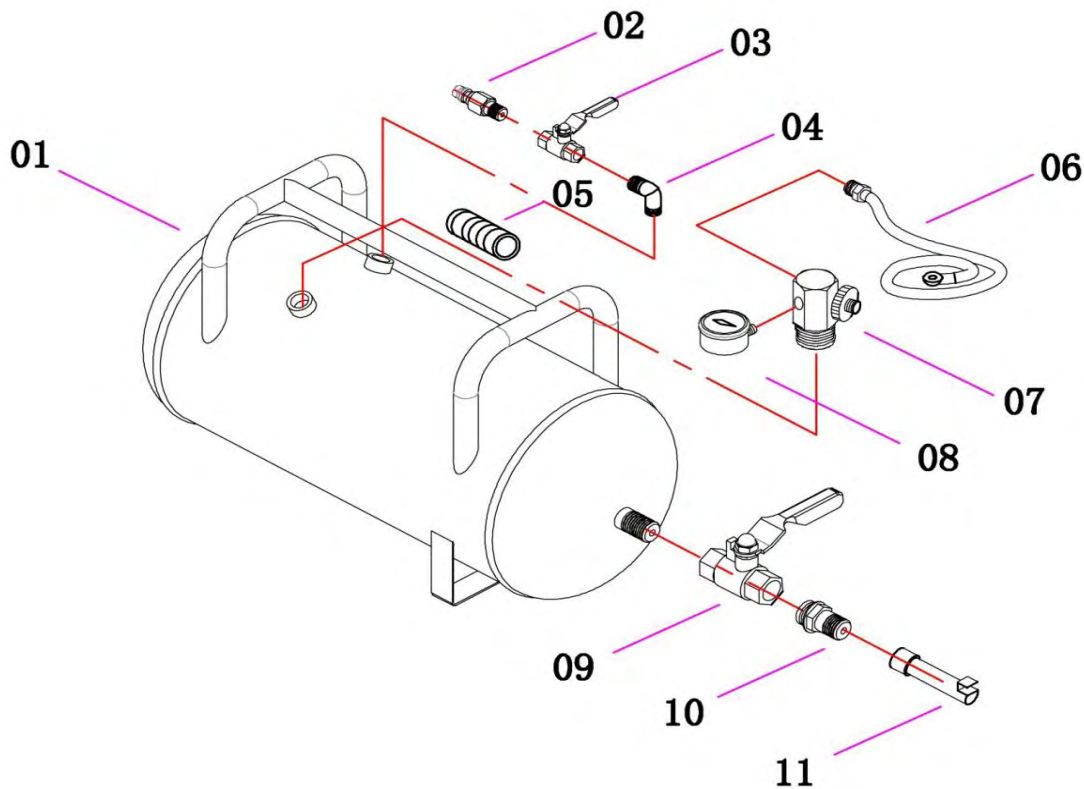

1	Air Tank
2	Quick Connect Male
3	1/4" Ball valve
4	1/4" Elbow
5	Hand Grip
6	Air Hose with Chuck

7	ASME Check Valve
8	Pressure Gauge
9	1.5" Ball Valve
10	Lock Nut
11	Tire Blaster Tube w/ Flange

DESCRIPTION

The EAGLE PORTABLE TIRE BLASTER and AIR TANK uses compressed air to properly seat the bead on Auto, ATV, and Truck tires. Please read the following instructions below before proceeding with tool operation.

OPERATION

BEFORE OPERATION

Check that you have received your EAGLE PORTABLE TIRE BLASTER and AIR TANK in good condition with no signs of damage. Please familiarize yourself with the components of this product (see component drawing on page 2). NOTE: The tire blaster tool should arrive fully assembled except for the threaded barrel which must be firmly threaded onto the release valve assembly before use. Read the following instructions and safety information before using this produce.

FILLING THE TIRE BLASTER TOOL WITH AIR

The tire blaster tool can be filled with air from any general commercial compressed air source. Please refer to the tank pressure information table (on page 7) for more information on tire type and suggested tank pressure before proceeding.

1. Make sure the air release valve is closed and attach the air supply line to the air connector on the tire blaster.
2. Open the air intake valve to fill the tire blaster tank to the desired air pressure.
3. When the pressure gauge indicates that the suggested tank pressure has been reached, close the air intake valve.
4. Disconnect the air supply line from the air connector.

USING THE TIRE BLASTER: HORIZONTAL TIRE/WHEEL POSITION

WARNING:

Always wear OSHA and ANSI approved safety gloves and eye protection when using the tire blaster. Make sure the area is clear of bystanders or hazardous materials before operating.

1. Position the wheel and tire flat on a tire stand so that the lower side wall is slightly off the floor.
2. Be sure to seat the lower tire bead on the bottom flange of the wheel.
3. Before attempting to seat the bead, make sure barrel flange (12) is on top (on the same side as the valve assembly shown on page 2). Rotate barrel to this position if necessary before proceeding.
4. Firmly hold the tire blaster by the handle and position barrel at an approximate 45° downward angle and place the barrel flange (12) on the upper edge of the wheel rim opposite the tire valve into the opening between the tire and rim. See drawing below.

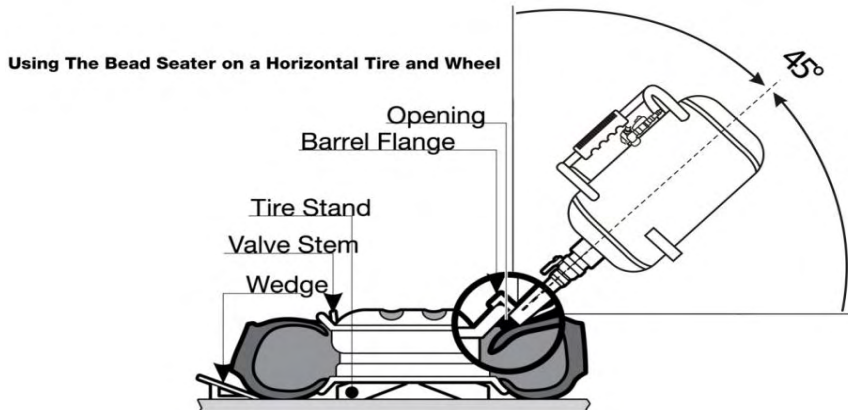

OPERATION continued

5. Open ball valve to release air from the tire blaster tool.
6. Once you have successfully seated the tire, connect an air supply line to the tire valve to complete tire inflation to correct pressure.

USING THE TIRE BLASTER: VERTICAL TIRE / WHEEL POSITION

WARNING:

Always wear OSHA and ANSI approved safety gloves and eye protection when using the tire blaster tool. Make sure the area is clear of bystanders or hazardous materials before operating.

NOTE: USE EXTREME CAUTION

This method should only be used when there is a large gap between the wheel rim and tire bead or if the tire is too heavy.

WARNING:

If the tire and wheel are not properly supported, they may fall forward when inflating causing harm to the tire blaster operator. **PLEASE USE EXTREME CAUTION!**

1. Position the tire and wheel so that it is tilted slightly back and secure it with a tire wedge. Make sure that the tire and wheel are supported away from the wall to be sure once inflated the tire and wheel **DO NOT FALL FORWARD CAUSING INJURY.**
2. The back bead of the tire (furthest from the operator) should be seated against the wheel rim trapping out any air. The front or wide flange of the wheel should be facing the operator with the tire valve stem positioned at the bottom of the tire.
3. Rotate the barrel so the barrel flange (12) is underneath (on the opposite side of the valve assembly shown on page 2).
4. Firmly hold the tire blaster by the handle and position barrel at an approximate 45° downward angle and place the barrel flange (12) on the edge of the wheel rim near the top of the wheel, opposite the tire valve, into the opening between the tire and rim. See drawing below.

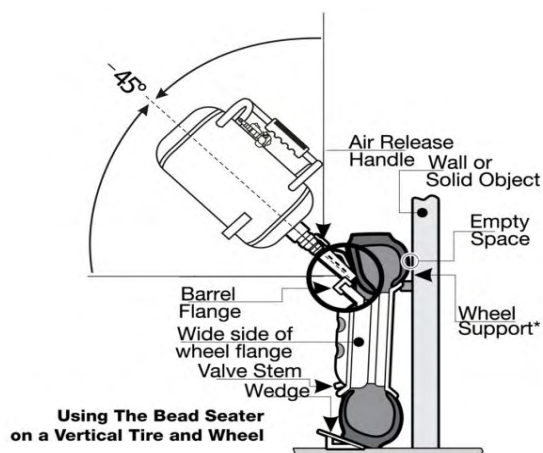

5. Open ball valve to release air from the tire blaster tool.
6. Once you have successfully seated the tire, connect an air supply line to the tire valve to complete tire inflation to correct pressure.

OPERATION continued

GENERAL MAINTENANCE INFORMATION

LUBRICATE

Lubricating all tire beads properly before using the tire blaster tool is important. Failing to lubricate beads may result in poor seating.

TIRE BLASTER ANGLE

Always hold the tire blaster tool at an angle so that the barrel points directly into the gap between the tire and rim, about 45° from vertical or horizontal depending on tire wheel position. This is important to ensure proper seating so that air does not hit the outside of the tire pushing the tire away OR the inside of the rim disallowing air to enter the tire.

TIRE BLASTER TOOL APPLICATION

The most effective position to apply the tire blasting tool is opposite the tire valve, and where the gap is largest. This results in both sides of the tire receiving an air supply, and ensures that the maximum amount of air enters the tire, creating the maximum lift. If a wedge has been properly used, the largest gap should be opposite the valve.

STORAGE

Always store the tire blaster in a cool, dry place, hanging by the handle with the air release valve open to ensure any built-up moisture drains from the tank; this also protects the barrel and attachments from damage.

NEVER STORE OR TRANSPORT A CHARGED TIRE BLASTER. ALWAYS CHARGE BEFORE USE AND DISCHARGE AFTER USE!

WARNING:

Be cautious of compressed air hazards, and keep away from flammable materials and vapors. Do not use the tire blaster for any other purpose than what it was designed for. In particular:

- DO NOT store or transport a charged tank.
- DO NOT use it for dusting down equipment or people.
- DO NOT discharge the tire blaster tool towards anyone.
- DO NOT clean a tire with a flammable solvent before using.
- DO NOT subject the tank to any stress or impact that might weaken it.

CONSTRUCTION

The barrel is threaded on to the air intake valve to allow for rotation. Before operating, the barrel must be orientated and tightened in accordance with the manual diagram on page 2. Pressure gauge accuracy is +/- 10%.

AIR SUPPLY/CHARGING

The EAGLE Tire Blaster has been tested and approved to ensure quality. The pressure release valve has been tested and cannot exceed 150 psi (10.3 bar). Ensure that the tire blaster tool is only charged immediately before use. The tire blaster tool must be charged from a clean, dry air supply, and should only be charged from a low pressure airline system (up to 150 psi/10.3 bar). Never fill with anything other than air at ambient temperature.

OPERATION continued

HEARING PROTECTION

Always wear ANSI approved hearing protection when using this tool.

EYE PROTECTION

ALWAYS wear approved OSHA and ANSI Z87.1-2003 safety goggles when operating this tool. Be considerate of bystanders when using this tool, and warn them accordingly.

TIRES - EXPLOSION RISK

Before using the bead seating tool on a tire or inflating any tire:

- ALWAYS inspect the tire and wheel for damage.
- ALWAYS ensure that any locking ring is secured in place.
- ALWAYS use a safety cage for inflating large tires or tires at high pressures.
- DO NOT over inflate the tire.
- DO NOT inflate damaged tires.

MAINTENANCE

Check the tire blaster tool regularly for damage or signs of wear, and ensure that the tank is inspected inside and out on a yearly basis. **NEVER TIGHTEN OR LOOSEN FITTINGS WHILE CYLINDER IS CHARGED!**

Items to check for:

- Make sure there are no cracks in the tank or fittings.
- The barrel is not damaged or bent and there are no obstructions to the barrel.
- NEVER tighten or loosen fittings while the cylinder is charged.

DRAINING

Drain the tire blaster tool regularly. To do this, hang the tire blaster up with the barrel positioned downward and open the air release valve.

TANK PRESSURE TABLE

Use the Tank Pressure Information Table below as a guide for recommended starting pressures; individual circumstances may require higher or lower pressures. Increase pressure if the tire blaster tool does not lift the tire bead far enough. Decrease pressure if the tire bead appears to seat at first and then falls off again.

VEHICLE TYPE	TIRE TYPE EXAMPLES	SUGGESTED TANK PRESSURE	TIPS
ATV	16-650-8 22-11-8 25-12-9 24-9-11	40 psi (2.7 bar)	Fit on stand, with stand in highest position. Can be fitted with the valve at the bottom.
Lawn Tractor	16-650-8 23-1050-12 26-12-12	40-50 psi (2.7-3.4 bar)	Use the stand in the highest position
Car	13" Rims 14" Rims	50-60 psi (3.4-4.1 bar)	If difficult, do not place on the stand - lean the rim against it. Ensure that valve is covered. Lubricate well.
4 x 4	15" Rims 16" Rims	60-80 psi (4.1-5.4 bar)	Fit in vertical position. Lubricate well. Ensure that the valve is covered by the tire.
Truck	11-22-5 18-22-5	100 psi (6.8 bar) 120 psi (8.2 bar)	Can be fitted vertically - i.e. still on the truck. Rotate the tire blaster tool spout to the correct position. If using stand, us in the lowest position.
Tractor	Up to 28" Over 28"	100 psi (6.8 bar) 120 psi (8.2 bar)	Fit horizontally, position the bottom bead on the rim, use the tire wedge.
Large Tractor	Terra Tires 48-31-20 66-43-25	120 psi (8.2 bar)	Fit vertically. Roll tire until the back bead is in position.

PARTS BREAKDOWN

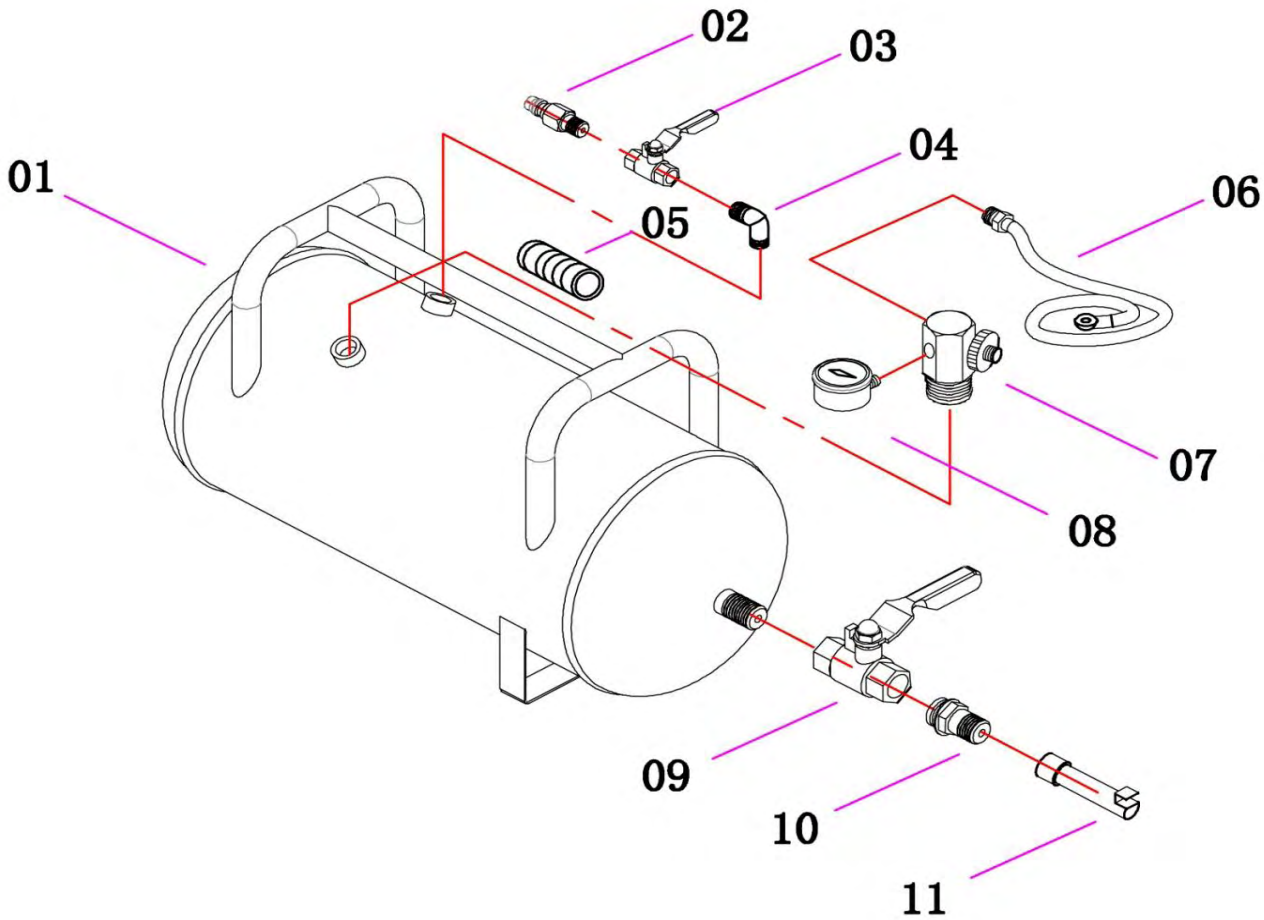

PARTS LIST

Ref. No.	Description	Qty.
1	Air Tank	1 pc.
2	Quick Connect Male	1 pc.
3	1/4" Ball valve	1 pc.
4	1/4" Elbow	1 pc.
5	Hand Grip	1 pc.
6	Air Hose with Chuck	1 pc.
7	ASME Check Valve	1 pc.
8	Pressure Gauge	1 pc.
9	1.5' Ball Valve	1 pc.
10	Lock Nut	1 pc.
11	Tire Blaster Tube w/Flange	1 pc.



STANDARD WARRANTY

Seller warrants products of its own manufacture against defects in workmanship and materials under normal use and service as follows:

Tire Blaster Brand	 EAGLE
Tire Blaster: months from date of purchase (receipt required)	12 Months

With respect to products not manufactured by **WII**, WII will, if practical, pass along the warranty of the original manufacturer.

Notice of the alleged defect must be given to Seller in writing with all identifying details including serial number, model number, type of equipment and proof of purchase, within thirty (30) days of the discovery of same during the warranty period.

WII's sole obligation on this warranty shall be, at its option, to repair, replace or refund the purchase price of any product or part thereof, which proves to be defective, F.O.B. **WII** shop.

If requested by **WII**, such product or part thereof must be promptly returned to **WII**, freight prepaid for inspection.

This warranty shall not apply and WII shall not be responsible nor liable for:

- a) Consequential, collateral or special losses or damages;
- b) Equipment conditions caused by normal wear and tear, abnormal conditions of use, accident, neglect or misuse of equipment, improper storage or damages resulting during shipment;
- c) Deviation from operating instructions, specification or other special terms of sale;
- d) Labor charges, loss or damage resulting from improper operation, maintenance or repairs made by person(s) other than **WII** or **WII** authorized service representative;
- e) Improper application of product.

In no event shall **WII** be liable for any claims, whether arising from breach of contract or warranty of claims of negligence or negligent manufacture, in excess of purchase price.

THIS WARRANTY IS THE SOLE WARRANTY OF WII AND ANY OTHER WARRANTIES, EXPRESSED, IMPLIED IN LAW OR IMPLIED IN FACT, INCLUDING ANY WARRANTIES OF MERCHANTABILITY AND FITNESS FOR PARTICULAR USE, ARE HEREBY SPECIFICALLY EXCLUDED.