

# Operator's Manual



Chicago Pneumatic Tool Company  
1800 Overview Drive • Rock Hill SC • 29730 USA

## **CP7763 & CP7763-6 Series Impact Wrench**

3/4" Square & 6" Extended Drive Model "K"

## **CP7773 & CP7773-6 Series Impact Wrench**

1" Square & 6" Extended Drive Model "K"



### **⚠ WARNING**

*To reduce risk of injury, everyone using, installing, repairing, maintaining, changing accessories on, or working near this tool must read and understand these instructions before performing any such task.*

# FOR DETAILED INFORMATION ABOUT CHICAGO PNEUMATIC AIR TOOLS AND EQUIPMENT CONTACT:

## UNITED STATES

**Chicago Pneumatic Tool Company**  
1800 Overview Drive  
Rock Hill, SC 29730 • USA  
Telephone: 1-803-817-7000  
1-800-367-2442 (USA only)  
Fax: 1-800-228-9096

## AUSTRALIA

Atlas Copco Tools Australia  
3 Bessemer Street  
Blacktown • Australia  
Telephone: 02-621-9482  
Fax: 02-671-5915

## BELGIQUE

Chicago Pneumatic Rep. Office  
Avenue Sluysmans 10-4030  
Liege • Belgium  
Tel/Fax: 04-343 8150

## BRASIL

Chicago Pneumatic Brasil  
Av. Mascote 159 V. Sta. Catarina  
04363-000  
Sao Paulo/SP • Brasil  
Telephone: (011) 562-7314  
Fax: (011) 563-9208

## CANADA

Chicago Pneumatic Tool Co.  
Automotive Division  
1800 Overview Drive  
Rock Hill, SC 29730  
Telephone: 1-803-817-7000  
Fax: 1-800-228-9096

## CENTRAL AMERICA

Contact Chicago Pneumatic/USA  
for names of CP Authorized  
Distributors in this area

## FRANCE

Espace Lumière  
Bâtiment S  
57, Boulevard de la République  
78403 Chatou Cédex. France  
Telephone: (0) 1 30 09 60 00  
Fax: (0) 1 30 71 96 70

## GERMANY

Desoutter GMBH  
Vehicle Service  
Edmund-Seng-Strasse 3-5  
D-63477 Maintal • Germany  
Telephone: 49-0611-270120/22  
Fax: 49-0611-270140

## INDIA

Chicago Pneumatic Sales  
Chemtex House, First Floor  
Main Street  
Hiranadani Gardens  
Powai, Mumbai 400076, India  
Telephone: (22)25704907  
(22)25708984  
Fax: (22)25705042

## ITALY

Desoutter Italiana S.R.L.  
Viale Della Repubblica, 65  
20035 Lisson (Milano)

## MEXICO

Chicago Pneumatic Tool  
Company Mexico  
San Francisco #223  
Valle Dorado, Tlalnepantla  
C.P. 54020 • Mexico  
Telephone: 525-378-0754  
Fax: 525-378-0753

## SOUTH AFRICA

Chicago Pneumatic Tool Company, S.A.  
20 Anvil Road  
PO Box 105  
Isando 1600, Transvaal • South Africa  
Telephone: 011-9746761  
Fax: 011-974-2324

## SOUTH AMERICA

Contact Chicago Pneumatic/USA  
for names of CP Authorized  
Distributors in this area

## SOUTHEAST ASIA

Chicago Pneumatic Tool Company  
Regional Office  
P.O. Box 1516  
Unit 2103 - Citimark  
28 Yuen Shun Circuit  
Shatin  
New Territories, Hong Kong  
Telephone: (8522) 3570963  
Fax: 852-763-1875

## SPAIN

Desoutter S.A.  
C. Serrano, 120  
28006 Madrid • Spain  
Telephone: 91 590 31 52  
Fax: 91 590 31 61

## SWEDEN

Chicago Pneumatic  
Distributor Markets  
Sickla Industriväg 7  
S-131 34 Nacka • Sweden  
Telephone: 46 8743 9329  
Fax: 46-8743 9427

## UNITED KINGDOM

Chicago Pneumatic Tool Company, Ltd.  
P.O. Box 241  
Eaton Road  
Hemel Hempstead, Herts HP2 7DR  
England  
Domestic: 01442-847703/06  
Export: 01442-232420/17  
Fax: 01442-2847723

Visit our website:  
<http://www.cp.com>



894016300 Rev03  
Printed in Taiwan  
KEK 02/09

# CP7763 & CP7773 Series Impact Wrench

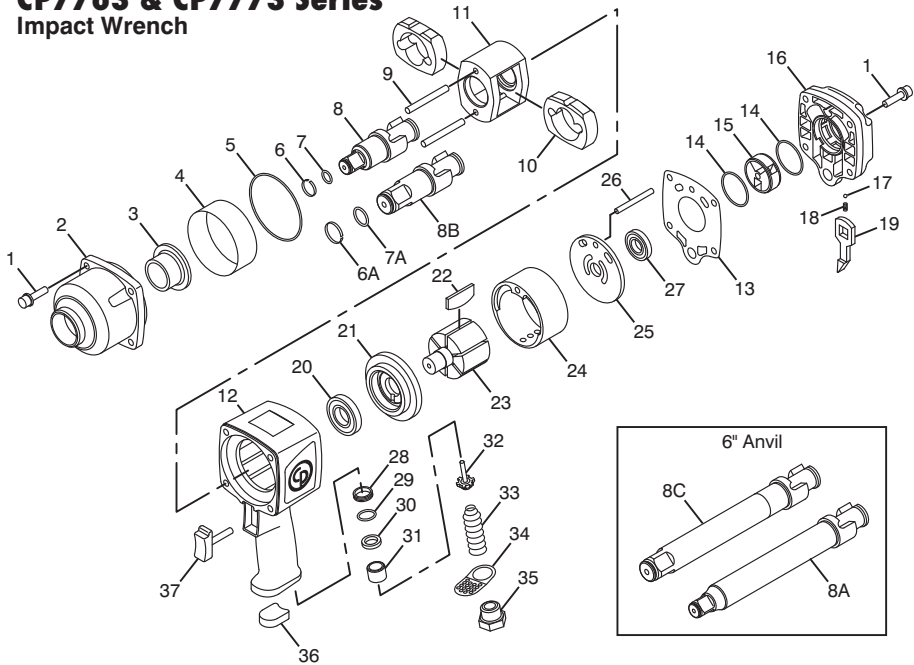

Index No.	Part No.	Description	No. Req'd.	Index No.	Part No.	Description	No. Req'd.
1	8940162843	Screw	8	27	8940162872	Bearing	1
2	8940162946	Clutch Housing Assembly (Incl: Index Nos. 2, 3)	1	28	8940162873	Insert Bushing	1
4	8940162846	Steel Ring	1	29	8940162874	O-Ring	1
5	8940162847	Gasket-Clutch Housing	1	30	8940162875	Seal	1
6	8940162848	Ring-Friction (3/4 in. Sq.)	1	31	8940162876	Bushing	1
6A	8940162904	Ring-Friction (1 in. Sq.)	1	32	8940162877	Valve-Throttle	1
7	8940162849	O-Ring (3/4 in. Sq.)	1	33	8940162878	Spring-Throttle Valve	1
7A	8940162905	O-Ring (1 in. Sq.)	1	34	8940162879	Exhaust Deflector	1
8	8940162947	Anvil (3/4 in. Sq. Dr.) Assembly (Incl: Index Nos. 6, 7, 8)	1	35	8940162880	Inlet Bushing	1
8A	8940162948	Anvil (3/4 in. Sq. Dr. 6 in. Extension) Assembly (Incl: Index Nos. 6, 7, 8A)	1	36	8940162881	Muffler	1
8B	8940162949	Anvil (1 in. Sq. Dr.) Assembly (Incl: Index Nos. 6A, 7A, 8B)	1	37	8940162882	Lever-Throttle	1
8C	8940162950	Anvil (1 in. Sq. Dr. 6 in. Extension) Assembly (Incl: Index Nos. 6A, 7A, 8C)	1				
9	8940162854	Pin	2				
10	8940162855	Dog	2				
11	8940162856	Cage	1				
12	8940162857	Housing-Motor	1				
13	8940162858	Gasket-Rear Cover	1				
14	8940162859	O-Ring	2				
15	8940162860	Reverse Valve	1				
16	8940162861	Rear Cover	1				
17	8940162862	Steel Ball	1				
18	8940162863	Spring	1				
19	8940162864	Lever-Reverse Valve	1				
20	8940162865	Bearing	1				
21	8940162866	Plate-Front End	1				
22	8940162867	Blades Set	6				
23	8940162868	Rotor	1				
24	8940162869	Liner	1				
25	8940162870	Plate-Rear End	1				
26	8940162871	Pin	1				

Tune-Up Kit for CP7763 & CP7763-6	
8940162925	(Incl: Index Nos. 5, 6, 7, 13, 14, 17, 18, 22, 29, 30)
Repair Kit for CP7763	
8940162927	(Incl: Index Nos. 5, 6, 7, 8, 9, 10, 13, 14, 17, 18, 22, 29, 30)
Repair Kit for CP7763-6	
8940162928	(Incl: Index Nos. 5, 6, 7, 8A, 9, 10, 13, 14, 17, 18, 22, 29, 30)
Tune-Up Kit for CP7773 & CP7773-6	
8940162926	(Incl: Index Nos. 5, 6A, 7A, 13, 14, 17, 18, 22, 29, 30)
Repair Kit for CP7773	
8940162929	(Incl: Index Nos. 5, 6A, 7A, 8B, 9, 10, 13, 14, 17, 18, 22, 29, 30)
Repair Kit for CP7773-6	
8940162930	(Incl: Index Nos. 5, 6A, 7A, 8C, 9, 10, 13, 14, 17, 18, 22, 29, 30)
Protective Boot	
8940163076	

## INSTRUCTION MANUAL

This product is designed for installing and removing threaded fasteners in wood, metal and plastic. No other use permitted. For professional use only.

### Air Supply Requirements

1. Supply tool with 90 psig (6.2 bar) of clean, dry air. Higher pressure drastically reduces tool life.
2. Connect tool to air line using pipe, hose, and fitting sizes shown in the diagram.

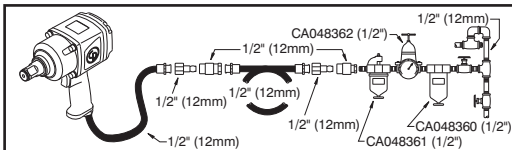

### Lubrication

1. Use an air line lubricator with SAE #10 oil, adjusted to two (2) drops per minute. If an air line lubricator cannot be used, add air motor oil to the inlet once a day.
2. Use 3 oz. (88 ml) of CP Pneu Lube Synthetic Clutch Grease 8940158455.

### Operation

1. The intended use of this impact wrench is with impact rated sockets operating upon threaded fasteners. To operate, pull trigger on handle. To operate in forward rotation, turn reverse valve toward forward arrow position. To operate in reverse, turn valve toward reverse arrow position.
2. This impact wrench is equipped with a regulator to enable adjustment of output power in both directions. Turn the regulator lever to # 3 for maximum power, to # 1 for minimum power.

### Maintenance

1. After first year, disassemble and inspect air motor and impacting clutch every three (3) months if the tool is used every day. Replace damaged or worn parts.
2. High wear parts are underlined in the parts list.
3. To keep downtime to a minimum, the following service kits are recommended:

#### Tune-Up Kit 8940162925

(Incl: 5, 6, 7, 13, 14, 17, 18, 22, 29, 30)

#### Repair Kit 8940162927

(Incl: 5, 6, 7, 8, 9, 10, 13, 14, 17, 18, 22, 29, 30)

#### Repair Kit 8940162928

(Incl: 5, 6, 7, 8A, 9, 10, 13, 14, 17, 18, 22, 29, 30)

#### Tune-Up Kit 8940162926

(Incl: 5, 6A, 7A, 13, 14, 17, 18, 22, 29, 30)

#### Repair Kit 8940162929

(Incl: 5, 6A, 7A, 8B, 9, 10, 13, 14, 17, 18, 22, 29, 30)

#### Repair Kit 8940162930

(Incl: 5, 6A, 7A, 8C, 9, 10, 13, 14, 17, 18, 22, 29, 30)

## EC DECLARATION OF CONFORMITY

We, Chicago Pneumatic Tool Company, 1800 Overview Drive, Rock Hill, SC 29730 USA, declare under our sole responsibility that the product to which this declaration relates, is in conformity with the requirements of the Council Directive of June 1998 on the approximation of the laws of the Member States relating to machinery (98/37/EC).

**Machine Name** CP7763 & CP7773 Series Impact Wrench

**Machine Type** Assembly Power Tool for Threaded Fasteners No other use is permitted.

**Serial No.** Tools with No. C 00001 2006 to C 99999 2006

### Technical Data

3/4" (19mm) & 1" (25mm) Sq. Dr. Std.

Air pressure 90 psi (6.2 bar)

Air Consumption 34.7 cfm

**Harmonized Standards Applied** EN292

**National Standards Applied** ISO 8662 7, ISO 15744 2002

**Name And Position Of Issuer** Stéphane Rakotoarivelo, General Manager, CP TechnoCenter, Nantes, France

**Signature Of Issuer** 

**Place And Date Of Issue** Saint Sebastien sur Loire, 44230 FRANCE, November 1, 2006

### Noise & Vibration Declaration\*

Sound pressure level 96 dB(A) impacting, 93 dB(A) free speed, in accordance with ISO 15744 2002. For sound power, add 11 dB(A).

Vibration value 9 m/s<sup>2</sup>, re. ISO 8662 7.

\*These declared values were obtained by laboratory type testing in compliance with the stated standards and are not adequate for use in risk assessments. Values measured in individual work places may be higher than the declared values. The actual exposure values and risk of harm experienced by an individual user are unique and depend upon the way the user works, the workpiece and the workstation design, as well as upon the exposure time and the physical condition of the user. We, Chicago Pneumatic, cannot be held liable for the consequences of using the declared values, instead of values reflecting the actual exposure, in an individual risk assessment in a work place situation over which we have no control.

### Copyright 2006, Chicago Pneumatic Tool Company

All rights reserved. Any unauthorized use or copying of the contents or part thereof is prohibited. This applies in particular to trademarks, model denominations, part numbers and drawings. Use only authorized parts. Any damage or malfunction caused by the use of unauthorized parts is not covered by Warranty or Product Liability.



## ⚠ WARNING

To reduce risk of injury, everyone using, installing, repairing, maintaining, changing accessories on, or working near this tool must read and understand these instructions before performing any such task.

2

The goal of Chicago Pneumatic is to produce tools that help you work safely and efficiently. The most important safety device for this or any tool is YOU. Your care and good judgment are the best protection against injury. All possible hazards cannot be covered here, but we have tried to highlight some of the important ones.

### For Additional Safety Information Consult:

- ▲ Your employer union and/or trade association.
- ▲ US Department of Labor (OSHA); [www.osha.gov](http://www.osha.gov); Council of the European Communities [europe.osha.eu.int](http://europe.osha.eu.int).
- ▲ "Safety Code For Portable Air Tools" (B186.1) available from: [www.ansi.com](http://www.ansi.com)
- ▲ "Safety Requirement For Hand-Held Non-Electric Power Tools" available from: European Committee for Standardization, [www.cenorm.be](http://www.cenorm.be)

### Air Supply And Connection Hazards

- ▲ Air under pressure can cause severe injury.
- ▲ Always shut off air supply, drain hose of air pressure and disconnect tool from air supply when not in use, before changing accessories or when making repairs.
- ▲ Never direct air at yourself or anyone else.
- ▲ Whipping hoses can cause serious injury. Always check for damaged or loose hoses and fittings.
- ▲ Do not use quick disconnect couplings at tool. See instructions for correct set-up.
- ▲ Whenever universal twist couplings are used, lock pins must be installed.
- ▲ Do not exceed maximum air pressure of 90 psi (6.2 bar) or as stated on tool nameplate.

### Entanglement Hazards

- ▲ Keep away from rotating drive.
- ▲ Do not wear jewelry or loose clothing.
- ▲ Choking can occur if neckwear is not kept away from tool and accessories.
- ▲ Scalping can occur if hair is not kept away from tool and accessories.
- ▲ Avoid direct contact with accessories during and after use. Gloves will reduce the risk of cuts or burns.
- ▲ Use only proper accessory retainers (see parts list). Use deep sockets wherever possible.

### Projectile Hazards

- ▲ Always wear impact-resistant eye and face protection when involved with or near the operation, repair or maintenance of the tool or changing accessories on the tool.
- ▲ Be sure all others in the area are wearing impact-resistant eye and face protection.
- ▲ Even small projectiles can injure eyes and cause blindness.
- ▲ Use only impact wrench sockets and accessories in good condition. Sockets in poor condition or hand sockets and accessories used with impact wrenches can shatter.
- ▲ Always use the simplest hook-up possible. Long, springy extension bars and adapters absorb impact power and could break. Use deep sockets wherever possible.

- ▲ Never operate the tool off of the work. It may run too fast and cause the accessory to be thrown off the tool.
- ▲ Serious injury can result from over-torqued or under-torqued fasteners, which can break, or loosen and separate. Released assemblies can become projectiles. Assemblies requiring a specific torque must be checked using a torque meter.

Note: So-called "click" torque wrenches do not check for potentially dangerous over-torque conditions.

### Workplace Hazards

- ▲ Slip/Trip/Fall is a major cause of serious injury or death. Beware of excess hose left on the walking or work surface.
- ▲ High sound levels can cause permanent hearing loss. Use hearing protection as recommended by your employer or OSHA regulation (see 29 CFR part 1910).
- ▲ Maintain a balanced body position and secure footing.
- ▲ Be in control of the throttle at all times. Do not get caught between the tool and the work.
- ▲ Repetitive work motions, awkward positions and exposure to vibration can be harmful to hands and arms. If numbness, tingling, pain or whitening of the skin occurs, stop using the tool and consult a physician.
- ▲ Avoid inhaling dust or handling debris from the work process which can be harmful to your health. Use dust extraction and wear respiratory protective equipment when working with materials which produce airborne particles.
- ▲ Proceed with care in unfamiliar surroundings. Be aware of potential hazards created by your work activity. This tool is not insulated for coming into contact with electric power sources.
- ▲ Some dust created by power sanding, sawing, grinding, drilling and other construction activities contains chemicals known to the State of California to cause cancer and birth defects or other reproductive harm. Some examples of these chemicals are:
  - Lead from lead based paints
  - Crystalline silica bricks and cement and other masonry products
  - And Arsenic and chromium from chemically-treated rubberYour risk from these exposures varies, depending on how often you do this type of work. To reduce your exposure to these chemicals: work in a well ventilated area, and work with approved safety equipment, such as dust masks that are specially designed to filter out microscopic particles.

### Additional Safety Topics

- ▲ This tool and its accessories must not be modified.
- ▲ This tool is not recommended for use in explosive atmospheres.
- ▲ Operators and maintenance personnel must be physically able to handle the bulk, weight and power of the tool.
- ▲ For professional use only.

# SAFETY INSTRUCTIONS

DO NOT DISCARD - GIVE TO USER